

# INSTRUCTIONS FOR EXTRA HEAVY DUTY ALUMINUM PLATFORMS

Catalog Number CPEHD-142, CPEHD-162, CPEHD-182,  
CPEHD-202 CPEHD-222, CPEHD-142-WKY, CPEHD-162-WKY,  
CPEHD-182-WKY, CPEHD-202-WKY, CPEHD-222-WKY

*Keep these instructions for future reference.*



## WARNING

Failure to read and follow all of the information presented here and with the associated equipment could cause damage to equipment, serious injury, or death.

## APPLICATION

Platforms are intended to be installed between two poles and hold from one to three pieces of equipment such as transformers, regulators, and reclosers. The platforms are supplied assembled. The extra heavy duty platform is attached to the two poles by 14 machine bolts (not supplied), seven bolts in each pole.

### Model CPEHD-142 and CPEHD-142-WKY

These models have two beams 16 feet long. The CPEHD-142-WKY is supplied with supports and hand railings for a 41 inch wide by 14 feet long walkway (walkway planks not supplied).

#### LOAD RATING:

Uniform Vertical Load	22,000 pounds
Single Center Vertical Load	10,000 pounds
Three Vertical Loads	6,220 pounds

### Model CPEHD-162 and CPEHD-162-WKY

These models have two beams 18 feet long. The CPEHD-162-WKY is supplied with supports and hand railings for a 41 inch wide by 16 feet long walkway (walkway planks not supplied).

#### LOAD RATING:

Uniform Vertical Load	17,742 pounds
Single Center Vertical Load	10,000 pounds
Three Vertical Loads	4,667 pounds

### Model CPEHD-182 and CPEHD-182-WKY

These models have two beams 20 feet long. The CPEHD-182-WKY is supplied with supports and hand railings for a 41 inch wide by 18 feet long walkway (walkway planks not supplied).

#### LOAD RATING:

Uniform Vertical Load	13,813 pounds
Single Center Vertical Load	8,633 pounds
Three Vertical Loads	3,700 pounds

### Model CPEHD-202 and CPEHD-202-WKY

These models have two beams 22 feet long. The CPEHD-202-WKY is supplied with supports and hand railings for a 41 inch wide by 20 feet long walkway (walkway planks not supplied).

#### LOAD RATING:

Uniform Vertical Load	11,058 pounds
Single Center Vertical Load	6,911 pounds
Three Vertical Loads	2,909 pounds

### Model CPEHD-222 and CPEHD-222-WKY

These models have two beams 24 feet long. The CPEHD-222-WKY is supplied with supports and hand railings for a 41 inch wide by 22 feet long walkway (walkway planks not supplied).

#### LOAD RATING:

Uniform Vertical Load	9,052 pounds
Single Center Vertical Load	5,657 pounds
Three Vertical Loads	2,381 pounds

## INSTALLATION



## WARNING

Improper installation can allow platform and/or equipment to fall.

Can cause property damage, personal injury or death.



1. Examine preassembled platform, four shear plates, eight bottom braces and hardware box making sure all parts are present and undamaged. Missing and/or damaged parts must be replaced before installation. Drawings of standard and walkway type platforms may be seen in Drawings SACPEHD182 and SACPEHD182WKY.

P216-0250

3/08/13  
Rev. A



2. The two mounting poles must be set close enough together so that at least 18 inches of the platform's main beams extend past the two inner pole faces. For example, if the beam length is 192 inches, the pole faces should be no greater than 156 inches apart ( $192 - 36 = 156$ ).
3. Using the shear plate as a template, drill seven through holes in each of the poles. The top hole should be 4" above the desired platform height. The hole spacing is specified in attached platform mounting drawing. It is important that the holes be drilled square through the pole to match shear plate holes on both sides of the pole. The holes should be large enough to accept  $\frac{3}{4}$ " through bolts, and should be level between the two poles.4. Before placing the platform between the poles, the outside bracket at each end should be removed. Bolts holding the inner brackets to the H-beam should be loosened (**not removed**). This will allow the inner brackets to slide freely on the beam and custom fit the pole face. It is helpful to leave the bolts loose until after the platform has been mounted.
5. Using approved safety procedures, lift and place the platform between poles. Install the top two  $\frac{3}{4}$ " bolts through the bracket and shear plates into the predrilled pole holes. Before proceeding further, check the platform for level. After confirming the platform is level, the outside brackets

and bottom braces are installed. Install outside brackets removed in step 4 onto top two through bolts. Install all bottom brackets using the lower through bolt and supplied bolts in bottom flange holes of cross channels. Be sure to use supplied spacer washer to maintain brace spacing. After application of brackets and braces tighten all fasteners.

6. The platform has six "hat" channels across the top of the beams that can be adjusted to meet the necessary mounting dimensions. The equipment is mounted on the hat channels. To adjust the hat channels, loosen the bolts and slide to the necessary dimensions. It is helpful to unseat the bolt heads by tapping bolt with a hammer before adjusting the channels.

**NOTE: The equipment must be spaced evenly on the platform for proper load distribution.**

7. After hat channel adjustment, tighten bolts firmly and mount equipment following manufacturer's recommendations and appropriate safety procedures.
8. If the platform is a walkway type, refer to Drawing SACPEHD182WKY for hand rail attachment. Drill a  $\frac{19}{16}$ " hole through each pole  $64\frac{3}{4}$  inches above the bottom through hole. Assemble hand rail per Drawing SACPEHD182WKY. Walkway planks and their attachment are the responsibility of the user. Follow your safety department's recommendations as to type of plank material and attachment means.
9. Do a final check of the installation being sure all bolts are tightened, the beams extend at least 18 inches beyond inner pole faces, and the equipment load is evenly distributed.

 <b>DANGER</b>	
	<b>Electrical contact hazard. Platform will conduct electricity.</b>
	<b>Contact with energized power line will cause death or severe personal injury.</b>
	<b>Do not let platform touch power lines.</b>
	<b>Maintain approved electrical clearances.</b>

These instructions do not claim to cover all details or variations in equipment, nor to provide for all possible conditions to be met concerning installation, operation, or maintenance of this equipment. If further information is desired or if particular problems are encountered which are not sufficiently covered in this guide, contact your Hubbell Power Systems representative or the factory at (573) 682-5521.



NOTE: Because Hubbell has a policy of continuous product improvement, we reserve the right to change design and specifications without notice.

©2013 Hubbell Power Systems, 210 N. Allen St., Centralia, MO 65240 USA

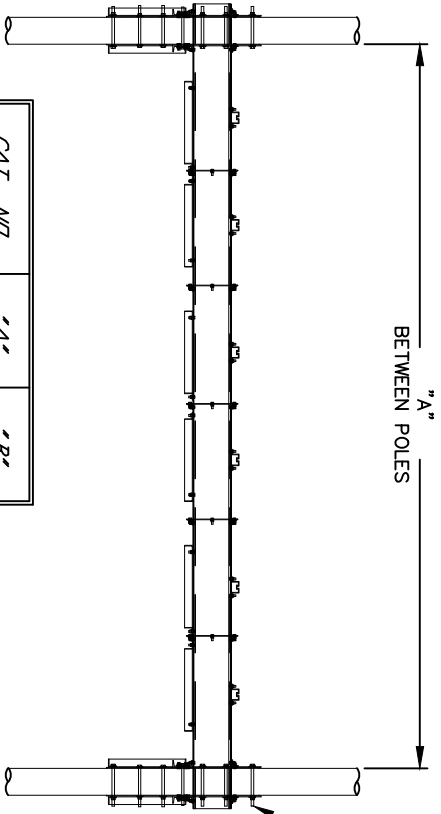
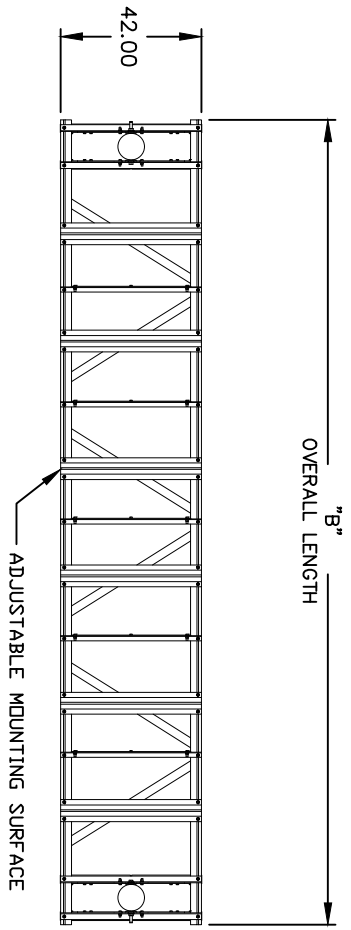

CAT. NO.	"A"	"B"
CPEHD142	13'	16'
CPEHD162	15'	18'
CPEHD182	17'	20'
CPEHD202	19'	22'
CPEHD222	21'	24'

NOTES=  
 1. MATERIAL: 6061-T6 ALUMINUM  
 GALVANIZED STEEL HARDWARE

3" MOUNTING BOLTS  
 (PURCHASED SEPARATELY,  
 7 PER SIDE, 14 TOTAL)

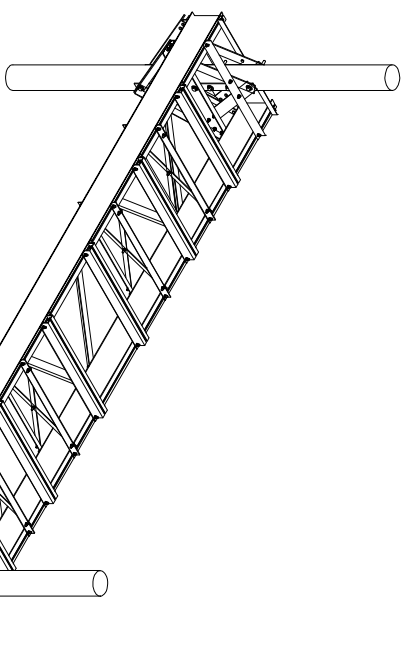
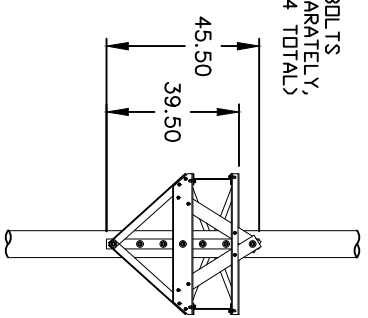

CHANCE TOLERANCE CHART		<b>HUBBELL POWER SYSTEMS</b>	<b>HUBBELL POWER SYSTEMS</b> PLATFORM, ALUMINUM	
CONFORMANCE: THIS DRAWING AND ITS CONTENTS ARE THE PROPERTY OF HUBBELL POWER SYSTEMS. NO REPRODUCTION, STORAGE, OR TRANSMISSION OF THIS DRAWING OR ITS CONTENTS WITHOUT THE WRITTEN CONSENT OF HUBBELL POWER SYSTEMS. UNPUBLISHED WORKS ARE PROTECTED UNDER THE COPYRIGHT LAWS.	TITLE HUBBELL POWER SYSTEMS		SIZE SBI SACEHD182	DWG NO. SEE CHART
DO NOT SCALE THIS DRAWING		DRN BY BERGER	DATE 12/04/12	SHEET 1 OF 1

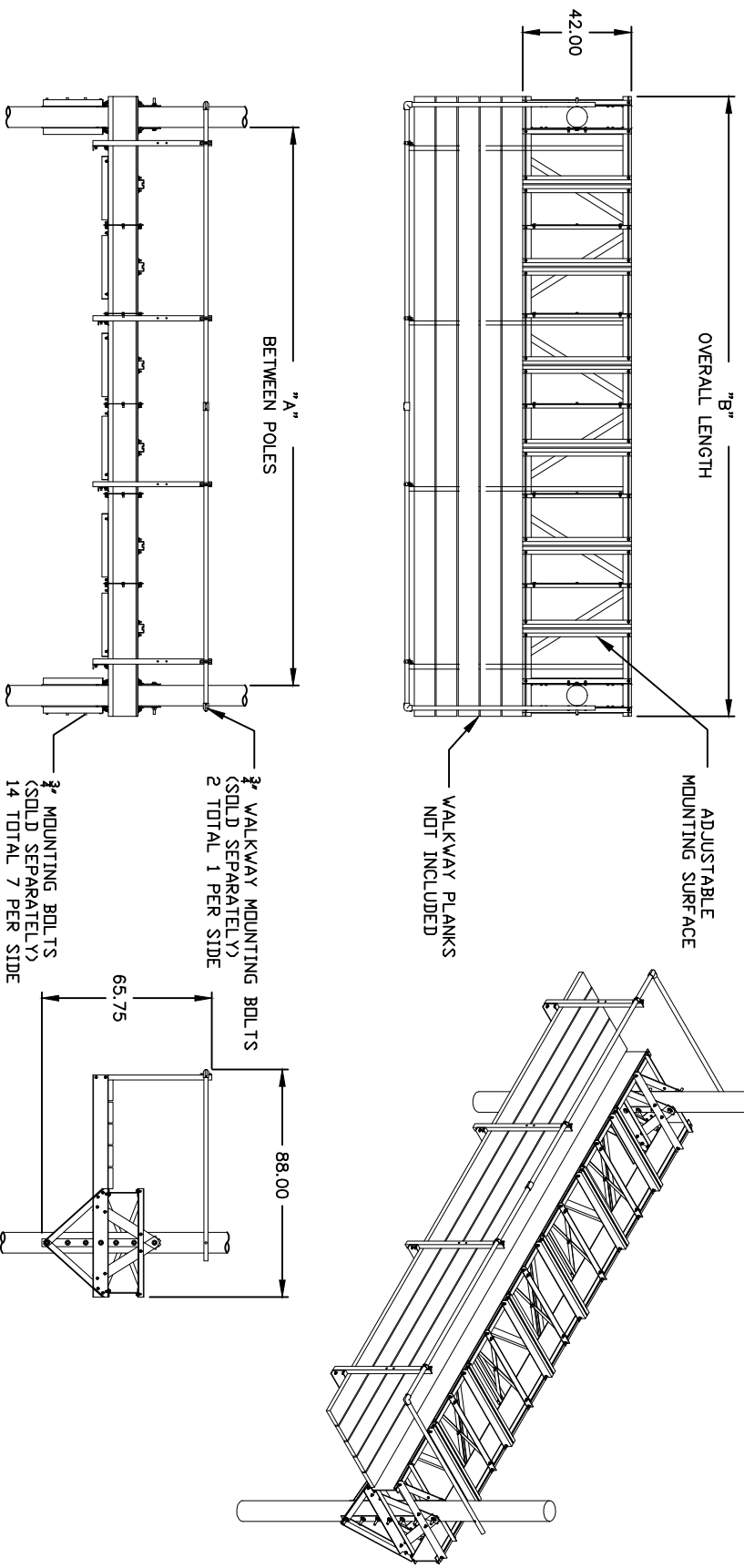

CAT. NO.	"A"	"B"
CPEHD142WKY	13'	16'
CPEHD162WKY	15'	18'
CPEHD182WKY	17'	20'
CPEHD202WKY	19'	22'
CPEHD222WKY	21'	24'

NOTES=  
 1. MATERIAL: 6061-T6 ALUMINUM  
 GALVANIZED STEEL HARDWARE

**CHANCE™ TOLERANCE CHART**

**HUBBELL POWER SYSTEMS**

**ALUMINUM PLATFORM,**

**ALUMINUM**

COMPENSATE THIS DRAWING AND THE EXCLUSIVE PROPERTY OF HUBBELL POWER SYSTEMS. NO PUBLICATION, REPRODUCTION, OR USE OF THIS DRAWING WITHOUT THE WRITTEN CONSENT OF HUBBELL POWER SYSTEMS. UNPUBLISHED HUBBELL POWER SYSTEMS UNDER THE COPYRIGHT LAWS.

SIZE	DWG NO.	DAT / PART / ASSY NO.	REV
DO NOT SCALE THIS DRAWING	SBI SACPETHD182WKY	SEE CHART	-
DEN BY BERGER	DATE 1/24/13	SHEET 1 OF 1	