

Apply down pressure to the helical pier installer to start the helical pier into the ground. Guide the helical pier installer for correct placement of the helical pier. Installation of a helical pier in obstruction laden soils may move the helical pier and installer head laterally and/or cause the torque bar to disengage its restraint. The restraining object must be able to resist the torque and restrain the bar from disengagement.

10. Helical pier advancement into the soil will cause the installer to move downward. Once the helical pier installer becomes level with the resisting end of the torque bar as shown in Figure 1, add helical pier extensions to the helical pier. Don't allow the installer end of the torque bar to go below the resisting end or the torque bar may move and break free of the torque restraint.

NOTE: The gage on the hydraulic control valve can be used to determine the torque output of the helical pier installer. Maximum torque is 2,500 ft-lb (3,390 Nm) at 1,550 psi (10,687 kPa).

**Calibration Data
for C303-1032
Hydraulic Helical Pier Installer**

Hydraulic Control Valve psi (kPa)	Torque ft-lb (Nm)
650 (4,481)	500 (677)
850 (5,860)	1,000 (1,356)
1,050 (7,239)	1,500 (2,024)
1,300 (8,963)	2,000 (2,711)
1,550 (10,687)	2,500 (3,390)

Hydraulic power source (not included)
2,500 psi (17,237 kPa) max and 8 gpm (30 L/min.)
Suggested power source -
CHANCE® hydraulic power unit C303-1201

⚠ WARNING

High-powered, hand-held machinery.
Can cause property damage, severe injury, or death.
Do not torque above 2,500 ft-lb (3,390 Nm). Over-torquing will damage the helical pier installer and can lead to personal injury or death.

11. To retrieve a helical pier, first move the torque bar so that it will restrain a clockwise rotation as shown in Figure 3 (counterclockwise, as shown in Figure 2, for left hand helices).
12. After moving the torque bar, activate the hydraulic control valve for counterclockwise (clockwise for left-hand helices) rotation.

⚠ WARNING

Crushing hazard.
Can cause property damage, severe injury or death.
Do not try to manually restrain torque bar.
Restrain torque bar against a solid object capable of withstanding 1,000 lb (4.5 kN) lateral force, in such a way that any movement of the torque bar under load will not allow it to disengage (see Figure 2).
Do not stand or place any body parts between the torque bar and the object restraining it. Keep all personnel clear of shaded area shown in Figure 2.
Minimum length of torque bar is 8 ft (2.4 m). A shorter length will not adequately restrain the torque.

**Retrieving a Helical Pier with
Right-Handed Helices (Standard)
View From Above**

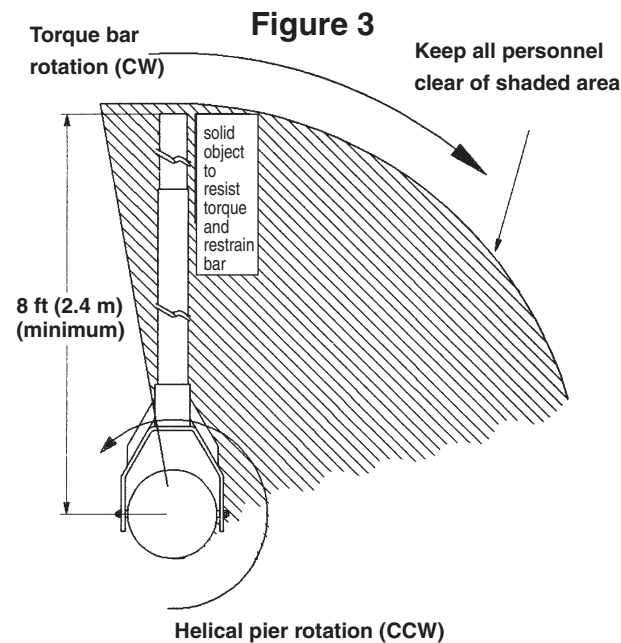

For repairs or service, consult Chance.

**Operating Instructions
2,500 ft-lb (3,390 Nm)
Hydraulic Helical Pier Installer Assembly
C303-1032**

C303-1032 consists of the 6 items pictured below.

⚠ WARNING

Read and Understand this instruction sheet completely before installing a helical pier. These instructions are intended to illustrate the use of Hydraulic Helical Pier Installer Assembly. Helical pier installing tools covered in this instruction sheet must be used by competent personnel familiar with and following good work and safety practices. Should additional information and details be desired, or if specific situations arise which are not covered adequately herein, the user should contact a Chance representative or telephone Chance at 573-682-8414.

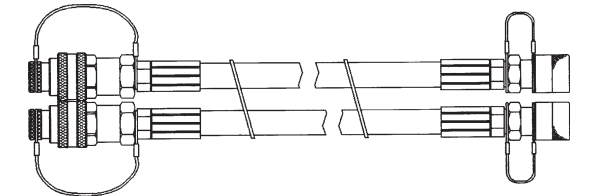

1. Two 12 ft (3.6 m) hoses
(Chance E303-0876 consists of 2)

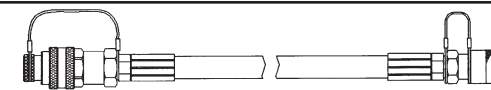

4. Two 25 ft (7.6 m) hoses
(each a Chance C417-6121)

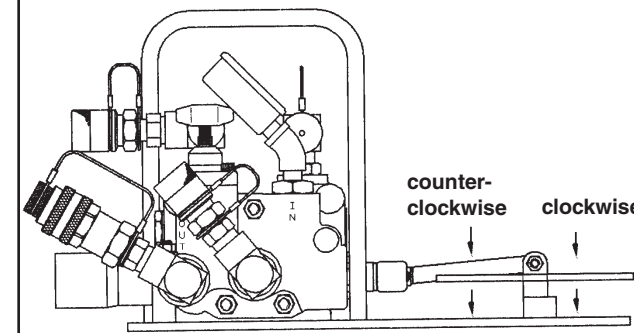

5. Hydraulic Control Valve C303-1031

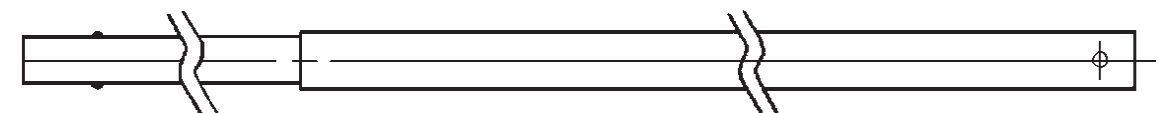

6. Square torque bar assembly - E303-1041

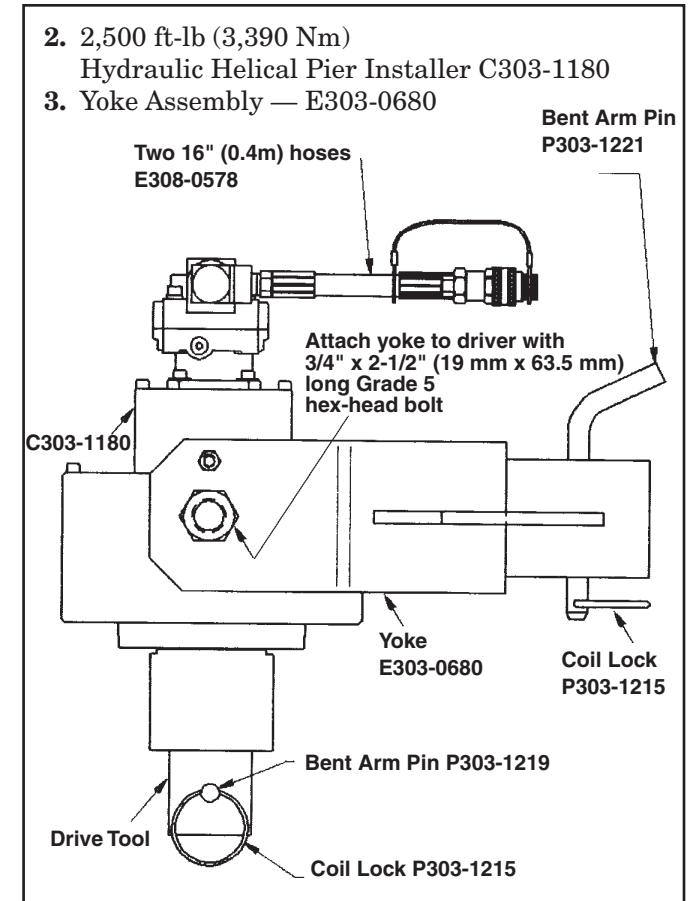

These instructions do not claim to cover all details or variations in equipment, nor to provide for all possible conditions to be met with concerning installation, operation, or maintenance of this equipment. If further information is desired or if particular problems are encountered which are not sufficiently covered in this guide, contact Chance.

NOTE: Because Hubbell has a policy of continuous product improvement, we reserve the right to change design and specifications without notice.



A.B. CHANCE is a Division
of Hubbell Power Systems, Inc.

Phone: 573-682-8414
Fax: 573-682-8660
www.abchance.com



A.B. CHANCE is a Division
of Hubbell Power Systems, Inc.

Phone: 573-682-8414
Fax: 573-682-8660
www.abchance.com

⚠ WARNING

High-powered, hand-held machinery. Misuse can cause property damage, severe injury or death. Do not use this machine unless you have read and understand all instructions and warnings in this instruction sheet P303-1094 and have been trained in the proper operation of this equipment.

Assembling for Operation

1. Assemble the plastisol coated eye bolts into the small holes in the yoke so that the eyebolts are inside the u-shape area of the yoke.
2. Attach the yoke to helical pier installer using two $\frac{3}{4}$ " (19 mm) spacers, $\frac{1}{4}$ " (6 mm) thick washers and $\frac{3}{4}$ " x $2\frac{1}{2}$ " (19 mm x 63.5 mm) long grade 5 hex head bolts provided with the yoke. Place the washers and spacers between the yoke and helical pier installer. The yoke should pivot after assembly, but rotation should be limited by the eye bolts. To avoid a pinchpoint condition, adjust eyebolts if necessary so that the yoke doesn't rotate more than 30 degrees below horizontal and hit the helical pier installer. NOTE: keep $\frac{3}{4}$ " (19 mm) hex head bolts tight.
3. Connect one end of each of the two 25 ft (7.6 m) long hoses to the hydraulic control valve and the other end to a hydraulic power unit or hydraulic power source as shown below in Figure 1.
4. Connect one end of each of the two 12 ft (3.6 m) long hoses to the helical pier installer hoses and opposite ends to the two male couplings on the hydraulic control valve as shown below in Figure 1. This connection controls the rotational direction of the helical pier installer. Connect the hoses so that the helical pier installer rotates in the clockwise direction when the operator steps on the outside edge of the foot pedal on the hydraulic control valve. Check for proper rotation each time the hoses are connected and reverse the hose connection at the helical pier installer if necessary. **The operator of the foot control must always know which direction the torque bar will rotate before stepping on the foot control to ensure safe operation.**
5. Insert the helical pier shaft into the drive tool on the helical pier installer and lock in place using the bent arm pin and coil lock provided. Check for three warning labels on both sides of the torque bar and one on the helical pier

⚠ WARNING

Inadequate maintenance or improper use of this machine may lead to unexpected failure. Can cause property damage, severe injury, or death. Frequently inspect tools, hardware and hydraulic hoses for damage, correct quantity, correct type, and proper torque. Replace as necessary with the same grade, type and size as the originals.

6. Attach the torque bar to the yoke using the bent arm pin; retain with the coil lock. The condition of the torque bar is an important factor affecting worker safety when installing helical piers. At least weekly, check end of the torque bar which goes into the yoke for cracks, particularly in the corner areas. Any cracking in the torque bar signals the end of its useful life. **Cracked torque bars must be replaced.** Use torque bar only with helical pier installers capable of a maximum of 2,500 ft-lb (3,390 Nm).
7. Before installing an anchor in the clockwise direction, position the torque bar as shown in Figure 2. (NOTE: Helical piers with left-hand helices will require positioning of torque bar per Figure 3 to install and Figure 2 to retrieve.) The end of the 8 ft (2.4 m) long torque bar must be positioned against a solid object capable of withstanding 1,000 lb (4.5 kN) of force in such a way that it will not disengage the restraint under load.

Figure 1



Installing a Helical Pier with Right-Handed Helices (Standard) View From Above

Figure 2

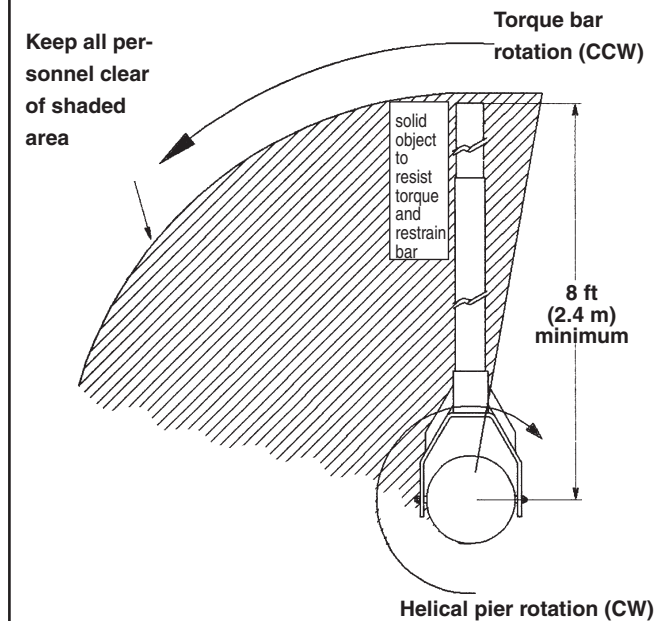

⚠ WARNING

Crushing hazard. Can cause property damage, severe injury or death. Do not try to manually restrain torque bar. Restrain torque bar against a solid object capable of withstanding 1,000 lb (4.5 kN) lateral force, in such a way that any movement of the torque bar under load will not allow it to disengage (see Figure 2). Do not stand or place any body parts between the torque bar and the object restraining it. Keep all personnel clear of shaded area shown in Figure 2. Minimum length of torque bar is 8 ft (2.4 m). A shorter length will not adequately restrain the torque.

8. The helical pier is now ready to install.

⚠ WARNING

Helical pier installation can puncture underground utility service. Can cause property damage, severe injury, or death. Locate and avoid all underground-utility services before installing a helical pier.

9. Activate the hydraulic control valve for a clockwise rotation (counterclockwise for left-hand helices).

