

# HUBBELL 30 AMP CIRCUIT-LOCK™ DISCONNECT SWITCH (HBLDS30 Series)

## Installation and Operation Instructions

**NOTICE: READ BEFORE INSTALLING AND USING THIS DEVICE.**

### GENERAL INFORMATION:

- This Disconnect Switch provides ON-OFF control of a directly connected load.
- These devices are suitable for indoor and outdoor locations where watertight, corrosion resistant, or dust tight protection is required.
- This **MANUAL MOTOR CONTROLLER** is additionally listed within its horsepower and voltage ratings as **SUITABLE FOR MOTOR DISCONNECT**, and provides ON-OFF switched **CONTROL** and **ISOLATION** of connected loads from its power supply.

**Assembled in U.S.A.  
Patent Pending**

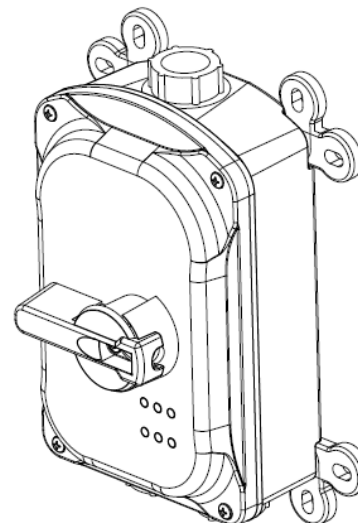

### **Important Safety Instructions - Save these Instructions**

- **NOTICE:** For installation only by a qualified electrician in accordance with the National Electrical Code® or the Canadian Electrical Code, local codes, and the instructions on the following pages.
- **CAUTION: RISK OF ELECTRIC SHOCK.** MORE THAN ONE SUPPLY DISCONNECT MAY BE REQUIRED TO DE-ENERGIZE THIS EQUIPMENT BEFORE SERVICING. DISCONNECT ALL POWER SUPPLIES TO ENCLOSURE BEFORE EXPOSING INTERIOR.
- **NOTICE:** Separate overcurrent protection must be provided upstream in accordance with the National Electrical code® Article 240 or Canadian Electrical Code, Section 14, as appropriate.
- FOR USE WITH COPPER CONDUCTORS ONLY.
- DO NOT tin conductors.
- Conductors shall be sized in accordance with the 60 °C column of Table 310.16 of the National Electrical Code or Table 2 of the Canadian Electrical Code. Conductor insulation shall be rated 90 °C or higher.
- Suitable for use on a circuit capable of delivering not more than 10,000 rms symmetrical amperes, 600 VAC maximum.
- Suitable for use on a circuit capable of delivering not more than 65,000 rms symmetrical amperes, 600 VAC maximum when protected by Class J fuses rated 30 amperes maximum.
- This Disconnect Switch includes a lockout provision: ON-OFF control knob (in the OFF position) accepts up to a 5/16 inch (8mm) diameter shackle of a suitable padlock Lockout device to isolate energy from the connected equipment as a method of compliance to OSHA Lockout/Tagout Regulation 29 CFR Part 1910.147. This feature, however, does NOT isolate the power supplied to the enclosure during internal servicing of the enclosure.

### RATINGS: HBLDS30 Series

TABLE 1	
30 Amp	600 VAC
1 HP	120 VAC 1Ø
3 HP	200-240 VAC 1Ø
5 HP	480 VAC 1Ø
7.5 HP	200-240 VAC 3Ø
15 HP	480 VAC 3Ø
15 HP	600 VAC 3Ø

TABLE 2	WIRE GA.	CONDUCTOR STRIP LENGTH	SCREW TORQUE
Switch	#8 to #14AWG	1/2 inch (13 mm)	50 lb-in (5.7 N-m)
Ground	#6 to #16 AWG	1/2 inch (13 mm)	35.4 lb-in. (3.9 N-m)
Neutral	#8 to #22 AWG	1/2 inch (13 mm)	35.4 lb-in. (3.9 N-m)
Auxiliary Contact	#14 to #18 AWG	1/2 inch (13 mm)	9 lb-in. (1.0 N-m)
800H Selector Switch	#8 to #10AWG	1/2 inch (13 mm)	6-8 lb-in (0.7-0.9 N-m)
800FP-SL32 Selector Switch	#8 to #12AWG	1/2 inch (13 mm)	6-8 lb-in (0.7-0.9 N-m)



# HUBBELL 30 AMP CIRCUIT-LOCK™ DISCONNECT SWITCH (HBLDS30 Series)

## INSTALLATION:

- This enclosure may be installed for top center, bottom, back, upper left side or bottom dual conduit entrances. Cat. No. HBLDS30T is supplied ready for top center conduit entrance.
- To access this device's interior, remove the enclosure's cover by unscrewing the four (4) cover screws. **Do not remove the handle screw.**

### A. MOUNT ENCLOSURE TO WALL OR EQUIPMENT SURFACE

1. **CAUTION:** Enclosure must be mounted to the surface by means of mounting feet provided. For Enclosure Type 4X or 12 installations, the mounting means **MUST** be **EXTERNAL** to the enclosure wiring interior. **DO NOT** drill, punch, or penetrate **THROUGH** the **ENCLOSURE WALLS** except for conduit holes.
2. Attach the feet to the enclosure's rear using the provided screws, tightened to 18 pound-inch (2.0 N•m). Each mounting foot can pivot 90°. See Fig. M-2.
3. Mount the feet to the surface using screws (not provided) up to ¼-inch (M6) maximum. See Fig. M-1.

### B. ATTACH CONDUIT TO ENCLOSURE

1. Remove the cover by first removing four (4) cover mounting screws.
2. Determine the location of the conduit hole(s) to be cut. For locations other than the upper left side, the metal frame should be removed prior to cutting the holes and re-installed after. Removal and re-installation of the metal frame is accomplished by removing and re-installing the frame retention screws.

Note: When connecting the upper left side hole location to a metallic conduit, a grounding (bonding) plate should be installed to ensure continuity of wiring system grounding. See Hubbell PD 3077.

1. Top feed is shown in Fig. M-3. Bottom feed is shown in Figs. M-4 and M-5.
2. For back feed or for dual conduit entry, see Section C and Figs. M-4 and M-5 for instructions.
3. Install the conduit fitting. Be sure that the "O" ring is properly seated in its groove. Tighten the conduit fitting.

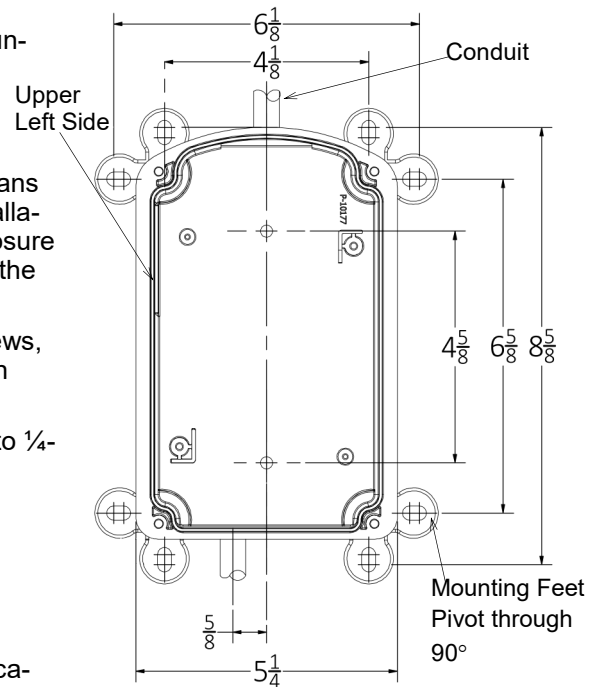

Dimensions in inches; for millimeters multiply by 25.4.

**Fig. M-1**

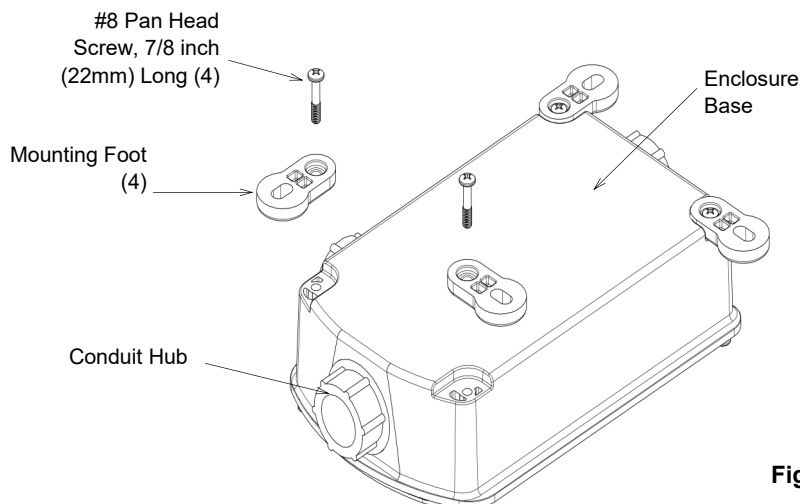
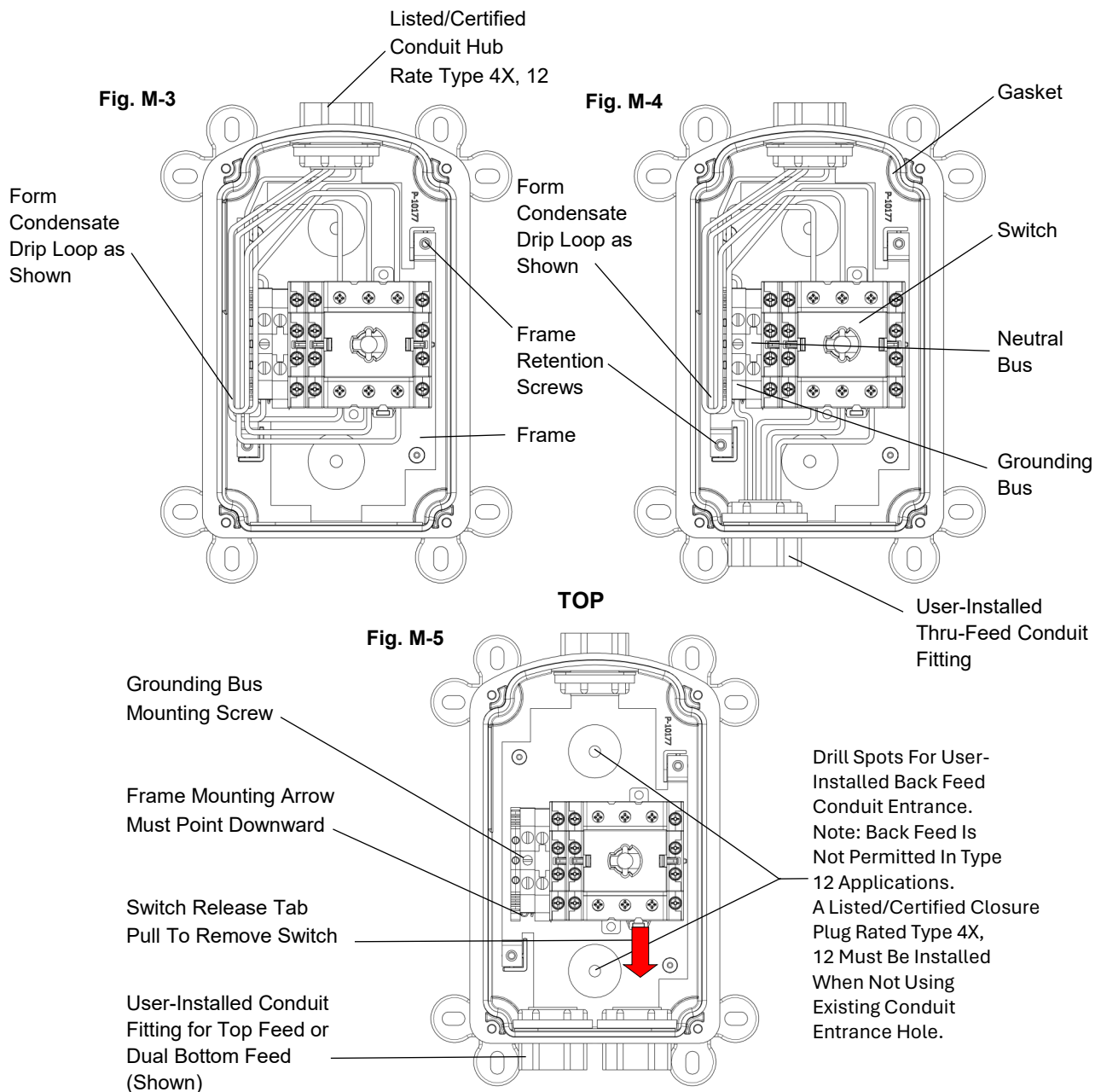

**Fig. M-2**

# HUBBELL 30 AMP CIRCUIT-LOCK™ DISCONNECT SWITCH (HBLDS30 Series)

**C. DUAL CONDUIT ENTRY AND BACK FEED:** See Figs. M-4 and M-5.

1. Remove frame retention screws and remove frame.
2. Drill or punch a 1.109 inch diameter (3/4" trade size) hole at the desired conduit entrance location. Use drill spots to accurately locate hole.
3. Use ONLY Listed/Certified conduit hub rated for Type 4X and Type 12 applications.
4. Any unused conduit entrance holes must be sealed with Listed/Certified closure plugs rated Type 4X and Type 12.
5. Use of user-installed conduit fitting above the switch are not recommended in applications where condensation may be present in conduit. When used in top feed application, drip loops must always be formed as indicated in Figs. M-3 and M-4.



# HUBBELL 30 AMP CIRCUIT-LOCK™ DISCONNECT SWITCH (HBLDS30 Series)

## D. WIRING INSTRUCTIONS

1. Caution: Ensure the connected device rating does not exceed the rating of this device. See General information regarding overcurrent protection.
2. Select the correct wiring diagram and wire the switch as shown.
3. Tighten ground terminal screws to 14.2 lb-in (1.6N·m); and neutral terminal screws to 14.2lb.-in.(1.6N·m).
4. Tighten the grounding bus mounting screw to 4.4-8.9 lb-in.(0.5-1.0 N·m).
5. Ensure there are no loose wire strands.
6. To reinstall the cover: Move the handle to the off position. Make sure the cover gasket is properly seated in the groove. Tighten the four cover screws to 18 lb. – in. (2.0 N·m).
7. Consult factory for auxiliary contact availability.

Wiring diagrams for catalogue HBLDS30 series

125 VAC 1Ø  
230 VAC 1Ø

208 VAC 1Ø  
240 VAC 1Ø  
485 VAC 1Ø  
600 VAC 1Ø

208 VAC 3ØΔ  
240 VAC 3ØΔ  
485 VAC 3ØΔ  
600 VAC 3ØΔ

120/240 VAC 1Ø

120/208 VAC 3ØY  
277/480 VAC 3ØY  
347/600 VAC 3ØY  
120/208/240 VAC 3ØΔ  
240/415/480 VAC 3ØΔ

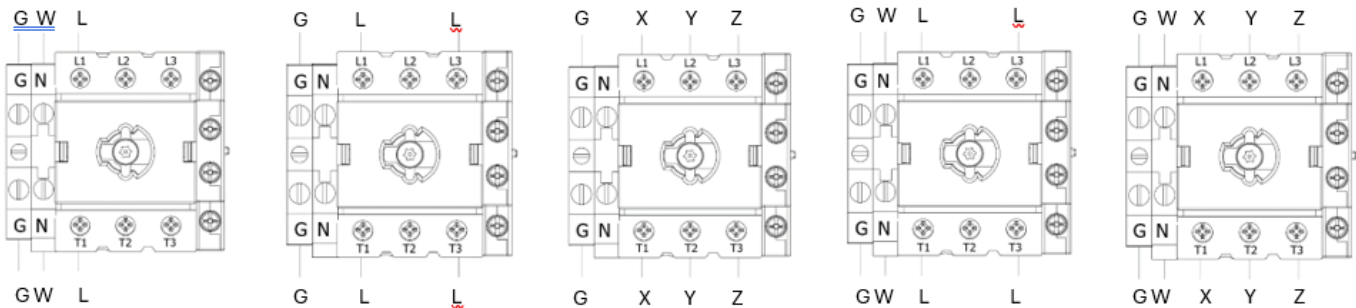

Note: "G" designates ground wire and yellow and green grounding buss.

Wiring diagrams for catalogue HBLDS30P series

125 VAC 1Ø  
208 VAC 1Ø  
230 VAC 1Ø

208 VAC 1Ø  
240 VAC 1Ø  
485 VAC 1Ø  
600 VAC 1Ø

208 VAC 3ØΔ  
240 VAC 3ØΔ  
485 VAC 3ØΔ  
600 VAC 3ØΔ

120/240 VAC 1Ø

120/208 VAC 3ØY  
277/480 VAC 3ØY  
347/600 VAC 3ØY  
120/208/240 VAC 3ØΔ  
240/415/480 VAC 3ØΔ

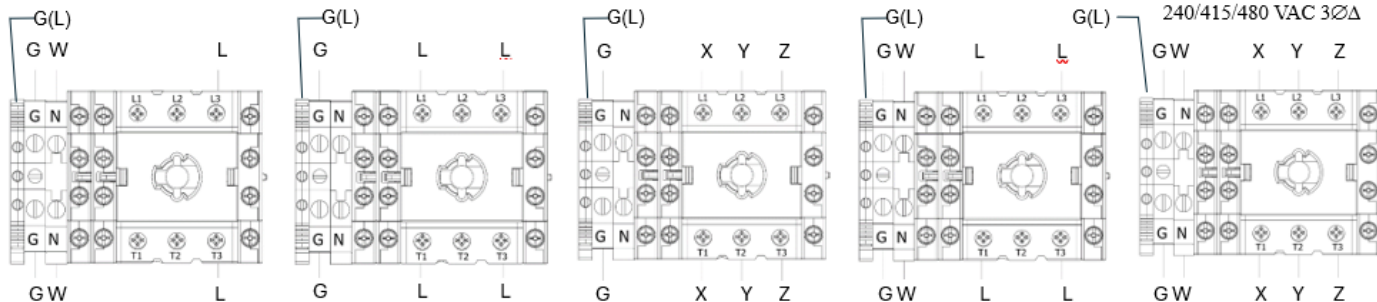

Note: "G" designates ground wire and yellow and green grounding buss.

Note: "GL" designates ground wire from the LED PCB to thinner yellow and green grounding buss.

"For all electrical distribution systems except three phase corner-grounded Delta configuration, secure green ground wire from circuit board to thinner (width) ground buss".

# HUBBELL 30 AMP CIRCUIT-LOCK™ DISCONNECT SWITCH (HBLDS30 Series)

## **CLEANING PROCEDURES:**

- **CAUTION:** Use only chemicals and cleaning solutions that are safe for use with plastics and rubber gaskets.
- **CAUTION:** Risk of electric shock. Do not clean this product while undergoing electrical maintenance or service
  1. Follow the general cleaning procedures established by your facility for your specific application.
  2. This product is certified by NSF International for use in food processing Splash Zone Areas, the following cleaning practice is recommended for this product:
    - a. Use hose directed water or cleaning solution to remove any collected soil or contaminants from behind this enclosure. Care must be exercised to apply the water spray in such a manner to completely wash the area between the enclosure and the wall onto which it is mounted.
    - b. Use hose directed water or cleaning solution to wash away soil or contaminants from the exterior surfaces of the enclosure.
    - c. **CAUTION:** Do not direct or concentrate high pressure water or cleaning solution on the lid and box gasket seams, switch handle area or on any applied labels.
    - d. After using hose directed water or cleaning solutions, use a clean damp cloth to manually remove any soil or other contaminants from the gasket seam area, handle area or other necessary areas.
    - e. Use a dry clean cloth to wipe away any excess water.

