

POWEROHM INSTALLATION MANUAL FOR “PW-NC” SERIES LOW CURRENT BRAKING MODULES



IMPORTANT: These instructions should be read thoroughly before installation. All warnings and precautions should be observed for both personal safety and for proper equipment performance and longevity. Failure to follow these instructions could result in equipment failure and/or serious injury to personnel. Braking modules contain lethal voltages when connected to the inverter. It is very important to remove power to the inverter before installing or servicing this unit. Always allow adequate time (approximately 5 minutes) after removing power before touching any components. The POWER ON LED must be completely out before servicing the unit.

TABLE OF CONTENTS

- Page 2: Table of Contents for “PW-NC” Series Manual Rev. 2014-03-18
- Page 3: Product Overview
- Page 4: Inspection and Environmental Conditions
- Page 5: Electrical Ratings
- Page 6: Equipment Installation
- Page 7: Mounting Dimensions and Weight
- Page 8: Wire Recommendations
- Page 9: Wire Sizing
- Page 10: Power Connections for PWx050NC and PWx115NC
- Page 11: Power Connections for PWx150NC
- Page 12: Control Connections
- Page 13: Module Set Up - Jumper Descriptions & Locations
- Page 14: Module Set Up - Jumper Positions & Factory Settings
- Page 15: Module Set Up – Voltage, Master & Fault Jumper Descriptions
- Page 16: System Integration - Drive DC Bus Connections
- Page 17: System Integration - Single Module Power Connections
- Page 18: System Integration - Master / Slave Power Connections
- Page 19: System Integration - Master / Slave Control Connections
- Page 20: Start Up
- Page 21: Start Up
- Page 22: Maintenance
- Page 23: Troubleshooting
- Page 24: Troubleshooting
- Page 25: Troubleshooting
- Page 26: Troubleshooting
- Page 27: Note Page
- Page 28: Back Page

AC variable frequency drives are commonly used with various types of motors to form reliable variable speed drive systems. Problems with these drive systems can occur when an application requires a deceleration rate faster than what can be managed by the drive alone, or when motor speeds exceed the synchronous speed set by the output frequency of the drive (which is called an overhauling load condition). Both of these conditions create regenerated power which flows from the motor back into the drive, causing its DC Bus to rise. To manage the regenerated power and avoid shutting the drive down due to an over-voltage trip, this power must be dissipated by an external braking resistor.

PowerOhm Type PW-NC Braking Modules can be used in conjunction with any AC drive to monitor the DC bus of the drive and **activate an external braking resistor** as needed not only to avoid over-voltage trips, but to greatly improve the performance of the drive system. The use of Braking Modules and resistors increase the braking torque capability of a variable frequency drive, allowing faster and more controlled deceleration times.

To accommodate system horsepower requirements beyond the capability of a single Module, the Modules are all Master/Slave programmable. This allows an arrangement of multiple Modules to effectively function as a single higher rated module.

INSPECTION UPON RECEIPT

Upon receipt of your PowerOhm Braking Module, be sure to carefully unpack the module and inspect the unit carefully for any shipping damage. The module contains electronics that can be damaged by static electricity, so handle in accordance with industry standards. Check for loose, broken or otherwise damaged parts due to shipping. Report any shipping damage immediately to the freight carrier. Be sure to verify that the part number and ratings listed on the nameplate match the order specification and the capabilities of the drive system. ***The ratings listed on the nameplate are critical – installing and energizing the incorrect part number could damage the braking module and/or the drive!***

ENVIRONMENTAL CONDITIONS

The PowerOhm Type PW-NC Braking Module should be installed in an environment protected from moisture and excessive dust. Dust buildup can reduce the electrical insulation characteristics of the unit and moisture can cause arcing or shorting. Air must be free of combustible gases and corrosive vapors. The Braking Module should be installed on a low vibration surface that is non-flammable.

Ambient Temperature Range: -10°C to 40°C

Maximum Altitude: 3300 feet (1000m)

Maximum Vibration: 10 to 20Hz, 32ft/sec/sec; 20 to 50Hz, 6.5 ft/sec/sec

ELECTRICAL RATINGS

The PowerOhm Type PW-NC Braking Module is available in three different voltage classes including 240, 480 and 600 volts. The continuous current ratings available are 50, 115, and 150 amps (* note that a cooling fan is used to achieve the 115 & 150 amp ratings). Peak currents up to the maximum are allowed at intermittent duty cycles, as long as the Module RMS Load Current rating is not exceeded (reference Table1).

$$\text{RMS Load Current} = \text{Peak Current} \times \text{the square root of duty cycle}$$

TABLE 1: General Specifications for PW-NC Braking Modules

PowerOhm Part No.	Nominal AC Line Voltage	Minimum Ohms @ listed Turn ON	Turn ON Voltage	RMS Cont Current	Max Peak Current	Max Watt Loss
PWA050NC	240	1.88	375vdc	50	200	137
PWA115NC	240	1.88	375vdc	115	200	293
PWA150NC	240	1.25	375vdc	150	300	369
PWB050NC	480	3.75	750vdc	50	200	146
PWB115NC	480	3.75	750vdc	115	200	302
PWB150NC	480	2.50	750vdc	150	300	378
PWC050NC	600	4.70	940vdc	50	200	156
PWC115NC	600	4.70	940vdc	115	200	312
PWC150NC	600	3.13	940vdc	150	300	388
PWD050NC	690	5.10	1020vdc	50	200	175
PWD115NC	690	5.10	1020vdc	115	200	351
PWD150NC	690	3.40	1020vdc	150	300	437

* 115 & 150 amp models require an externally powered fan to meet RMS ratings.

The PowerOhm Type PW-NC Braking Module should be installed on a low vibration surface that is non-flammable.

ATTENTION: Installation and removal of this equipment should be done by qualified personnel only. Equipment must be installed in accordance with all applicable national and local electrical codes and regulations.

MOUNTING REQUIREMENTS

To allow proper cooling, it is very important to install convection cooled PowerOhm braking modules in the vertical position (see Figure 1). A convection cooled model is simply a unit without a factory installed cooling fan. If the braking module includes the optional cooling fan, the chassis can be orientated in any position.

A convection cooled braking module requires a minimum of 2 inches of clearance around all sides. A fan cooled module requires a minimum of 4 inches above the fan exhaust face to allow proper cooling.

Figure 1: Mounting Position for Convection Cooled Modules

CORRECT

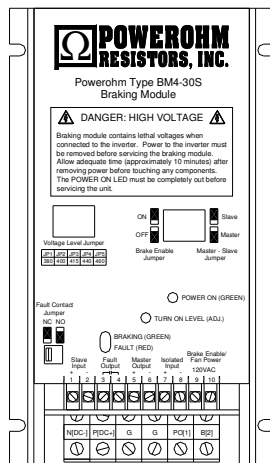

UP
↑

INCORRECT

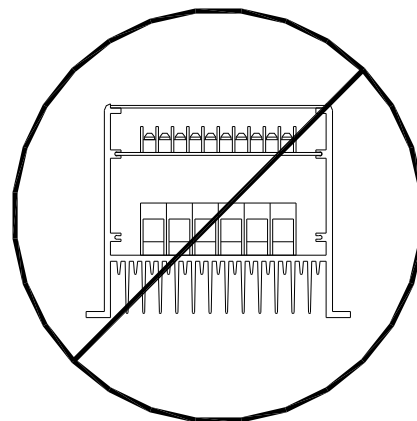

DIMENSIONS AND WEIGHT

The PowerOhm Type PW-NC Braking Module shown in Figure 2 includes the details of the fan cooled model (optional fan is shown with dashed lines). Note that the height will be 11 inches without the fan kit.

Figure 2: Braking Module Dimensions

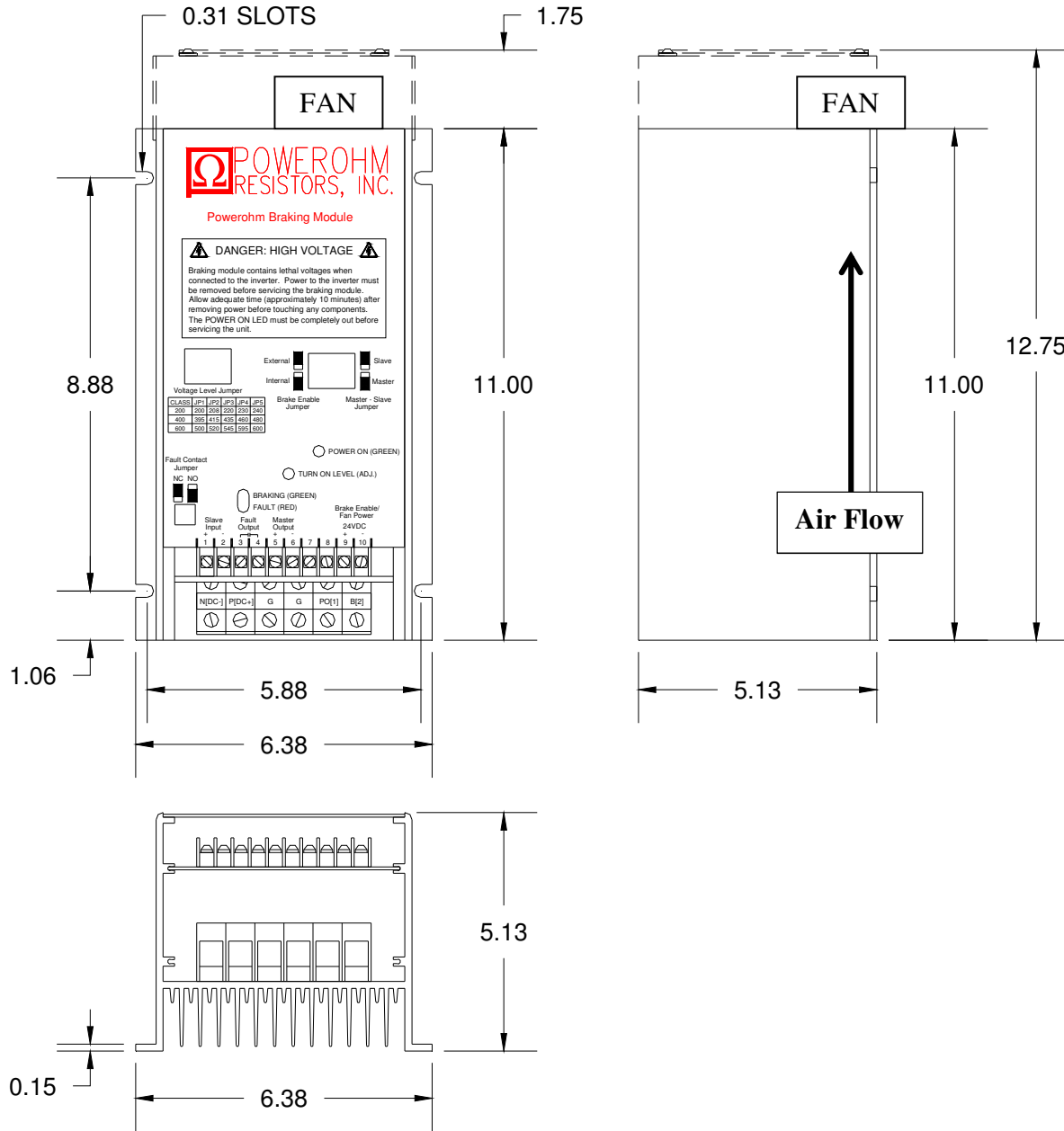

Weight: For PWx050NC the weight is approximately 8 lbs; For PWx115NC & 150NC the weight (with fan) is approximately 10 lbs.

WIRING RECOMMENDATIONS

It is recommended that the AC drive manual, braking resistor instructions and any other pertinent documentation be thoroughly reviewed before proceeding. Note that control and power wiring should be separated to avoid electrical noise and interference problems. The wiring between the drive and braking module should not exceed 15 feet and between the braking resistor and braking module should not exceed 30 feet.

Important: Always properly ground each component to earth. For best noise immunity connect Braking Module chassis ground directly to AC Drive Module Power earth ground, and ensure the drive cabinet has a good ground.

Figure 3: Wiring Lengths Between Drive System Components

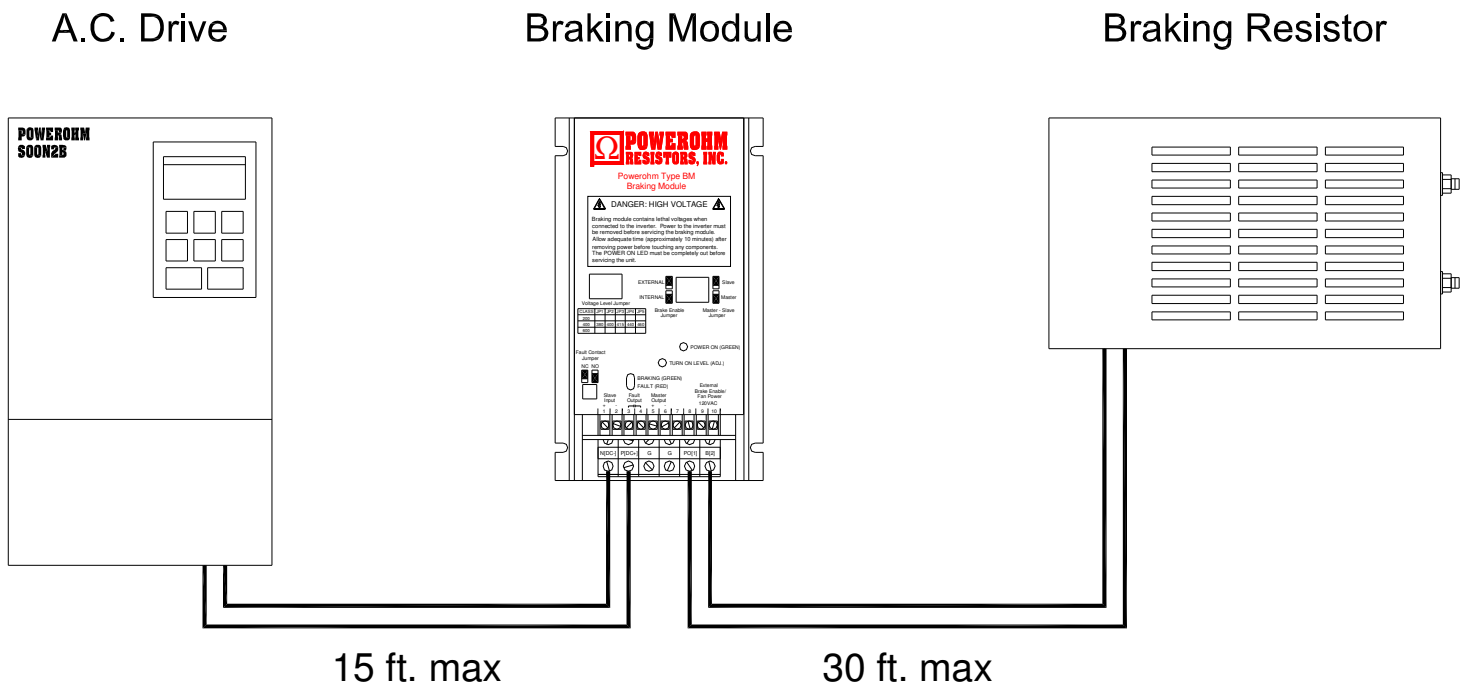

WARNING: Never install a braking resistor directly across the DC bus of the drive. Drive damage or failure may occur upon applied power or, the resistor will dissipate power continuously and be subject to overheating and failure.

WIRE SIZING

Reference Table 2 for suggested minimum wire sizes only. Keep in mind the duty cycle rating greatly affects the minimum wire size needed.

TABLE 2: Wire Sizing for Power Interconnections

Motor HP at 10% Duty Cycle			WIRE SIZE
240VAC	480VAC	600VAC	
1HP to 50HP	1HP to 75HP	1HP to 75HP	10 AWG
60HP to 100HP	100HP to 150HP	100HP to 150HP	8 AWG
N/A	200HP-250HP	200HP-250HP	6AWG
Motor HP at 30% Duty Cycle			WIRE SIZE
240VAC	480VAC	600VAC	
1HP to 30HP	1HP to 40HP	1HP to 40HP	10 AWG
40HP to 75HP	50HP to 75HP	50HP to 75HP	8 AWG
100HP	100HP to 250HP	100HP to 250HP	6 AWG

Note: 18 AWG wire is sufficient for all control and signal wiring

ATTENTION: The National Electric Code (NEC) and local regulations govern the installation and wiring of electrical equipment such as braking resistors and modules. DC power wiring, AC power wiring, control wiring and conduit must be installed in accordance with all applicable codes and regulations.

POWER CONNECTIONS

The PowerOhm Series PW-NC Braking Module features a total of four power connections and an earth ground. Terminal location and size is dependent on the current capacity of the model. See reference tables 3a, and 3b for a description of each terminal's function, torque, type of connection and wire size.

TABLE 3a: Description of Power Connections for LGx-50 & LGx-115 Models

Terminal Designation	Terminal Description	Maximum Torque (lb-in)	Connection Type	Max Wire Size
N [DC -]	DC Bus Negative	80	Tubular Clamp	6 awg
P [DC+]	DC Bus Positive	80	Tubular Clamp	6 awg
	No Connection			
	No Connection			
PO [1]	Braking Resistor	80	Tubular Clamp	6 awg
B [2]	Braking Resistor	80	Tubular Clamp	6 awg
	Power Earth Ground	50	Tubular Clamp	4 awg

LGx-50 & LGx-115 Power Terminals



TABLE 3b: Description of Power Connections for LGx-150 Models

Terminal Designation	Terminal Description	Maximum Torque (lb-in)	Connection Type	Max Wire Size
N [DC -]	DC Bus Negative	80	Tubular Clamp	1/0
P [DC+]	DC Bus Positive	80	Tubular Clamp	1/0
PO [1]	Braking Resistor	80	Tubular Clamp	1/0
B [2]	Braking Resistor	80	Tubular Clamp	1/0
	Power Earth Ground	50	Tubular Clamp	4 awg

LGx-150 Power Terminals

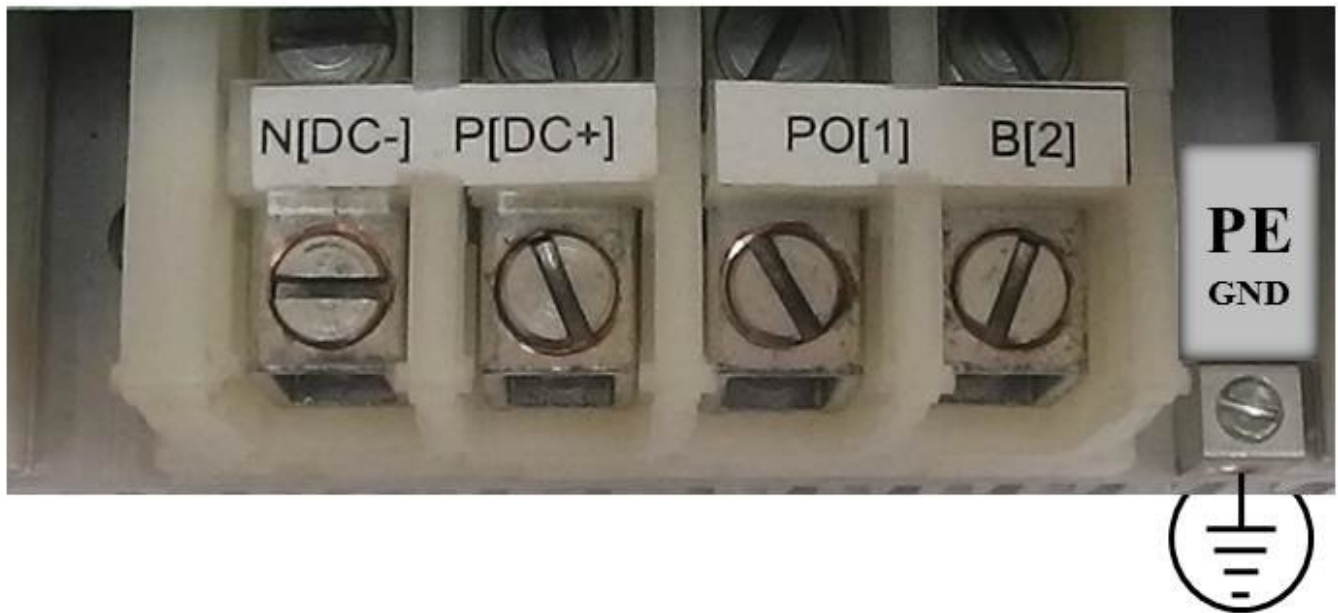

The PowerOhm Series PW-NC Braking Module features a 10-position terminal block for all signal and control wiring. All terminations on the block can accept bare wire or fork lugs for a #6 screw. Reference Table 4 for a description of each terminal.

TABLE 4: Description of Control Connections for All PW-NC Models

Terminal Number	Terminal Description	Electrical Ratings	Maximum Torque (lb-in)
1	Slave Input Pulse (Positive)	24vdc @ 10ma	7
2	Slave Input Pulse (Negative)	24vdc @ 10ma	7
3	Fault Contact Output (NO or NC)	125vac/24vdc @ .5a	7
4	Fault Contact Output (NO or NC)	125vac/24vdc @ .5a	7
5	Master Output Pulse (Positive)	24vdc @ 50ma	7
6	Master Output Pulse (Negative)	24vdc @ 50ma	7
7	Non-functioning termination	N/A	7
8	Non-functioning termination	N/A	7
9	120VAC external Enable & Fan	.5a @ 125vac	7
10	120VAC external Enable & Fan	.5a @ 125vac	7

Note: 18 AWG wire is sufficient for all control and signal wiring

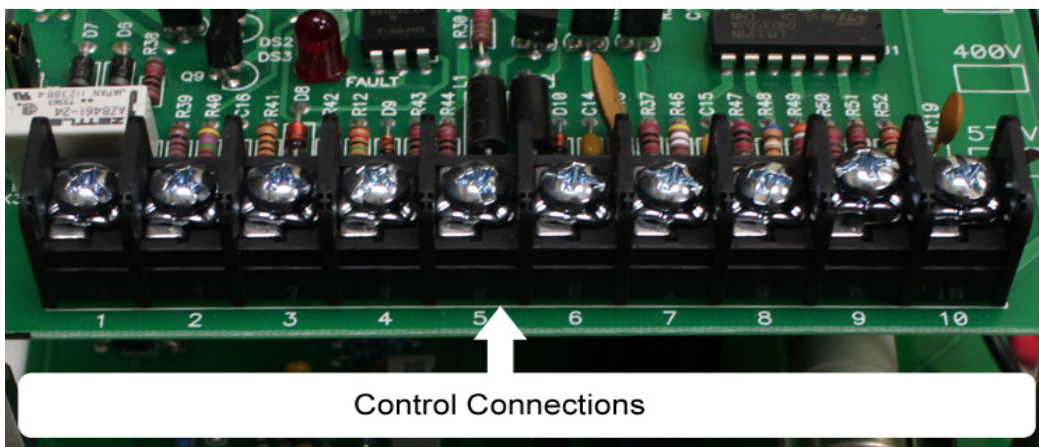

The PowerOhm Series PW-NC Braking Module has several jumper settings that are accessible on the main circuit board. The front cover must be removed to change the jumper.

Warning: Do not make jumper changes while power is applied! Change as required only after power is removed and the green power indicator is off! Use insulated tools when changing jumper positions.

TABLE 5: Description of Jumper Settings

Jumpers	Jumper Description
JP1-JP5	Set to match the actual on site AC line voltage
JP6	Selects Internal or External Brake Enable
JP7	Selects a Master or Slave configuration
JP8	Selects a NC or NO Fault contact.

FIGURE 4a: Control Board Jumper Locations

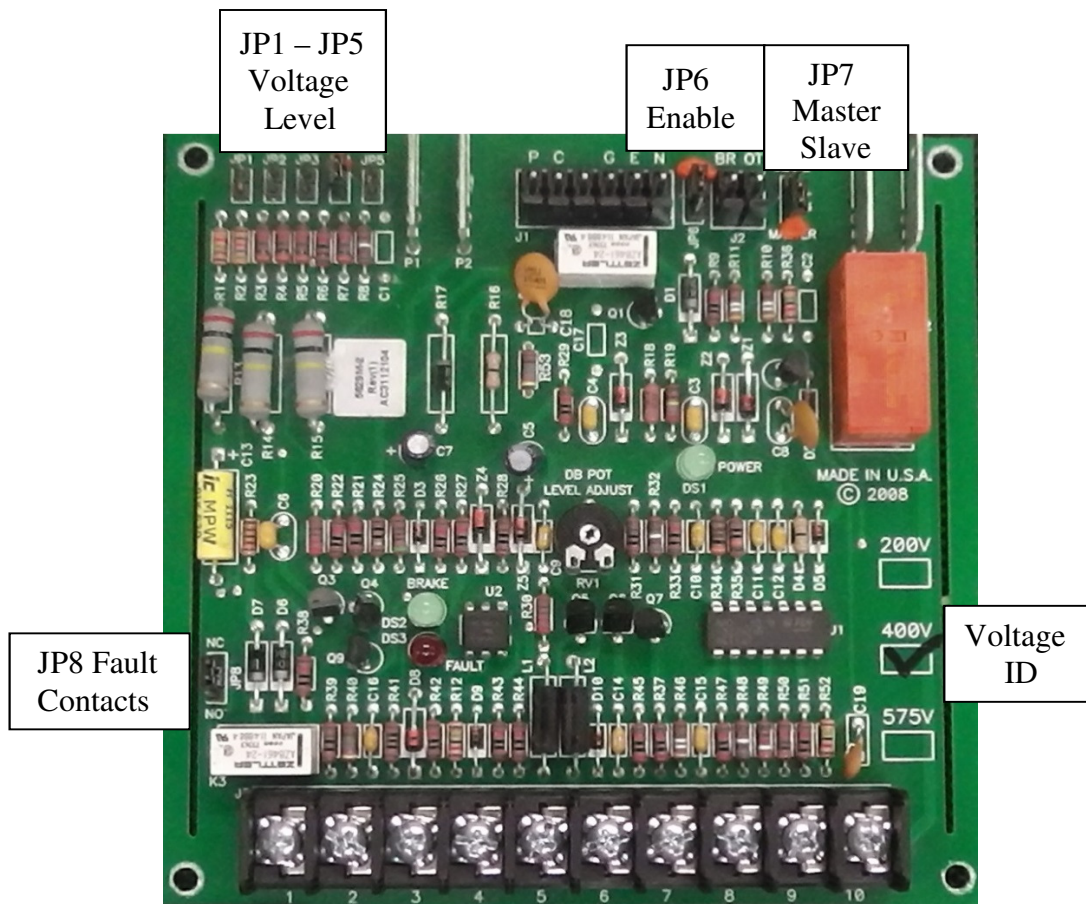
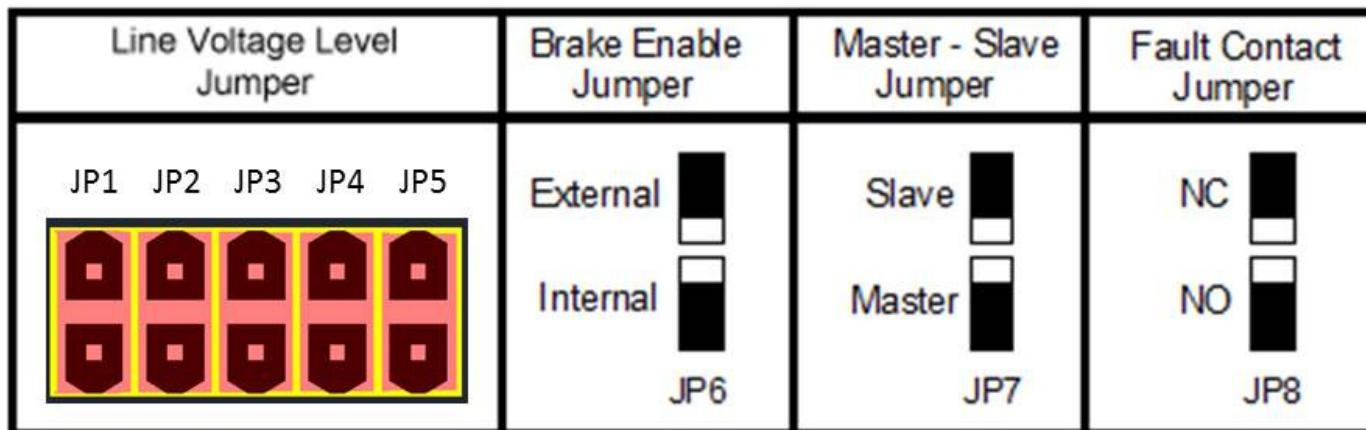

FIGURE 4b: Control Board Jumper Positions



Brake Enable Jumper: JP6 selects between internal enable or external enable modes

Internal (Automatic): When the JP6 jumper is in the downward position, the Brake is Enabled automatically whenever system DC Bus voltage is applied. Note that PW-NC models still need voltage at terminals 9 & 10 for the cooling fan.

External: When the JP6 jumper is in the upward position, the Brake is Enabled ONLY when voltage is applied to control terminals 9 and 10. This position is recommended so the Brake can be disabled when the drive is not running.

- The PWx115NC & PWx150NC models REQUIRE voltage at terminals 9 & 10 to run the cooling fan regardless of the position of JP6

TABLE 6: Factory Installed Enable Jumper Settings

PowerOhm Part No.	JP1-JP5 AC Line Voltages	JP6 Brake Enable	JP7 Master Slave	JP8 Fault Contact
PWx050NC	200-600	Internal	Master	NC
PWx115NC		External		
PWx150NC		External		

CAUTION: If the Enable Jumper is set to INTERNAL with power applied to an idle drive, the bus voltage can reach a value high enough to turn on the brake module, potentially causing the brake resistor to over-heat.

Line Voltage Level Jumpers: The voltage ID box in fig 4a indicates which voltage class the control board is set up for and the voltage class determines the DC threshold level expected for each jumper position. PW-NC series braking modules are calibrated to the DC voltages shown in the JP4 column in table 7, with JP4 ON. Moving the jumper to another position changes the DC turn on thresholds as shown in table 7.

TABLE 7: DC Voltage turn on voltages for PW-NC models

Voltage Class	JP1	JP2	JP3	JP4	JP5
200vac	323vdc	339vdc	355vdc	375vdc	391vdc
400vac	646vdc	677vdc	709vdc	750vdc	782vdc
600vac	813vdc	853vdc	892vdc	940vdc	980vdc

If the actual drive input AC Line voltage differs from the factory default setting considerably, and the external enable command is not used, it may be necessary to change the jumper setting to match the power source.

- *Generally speaking, it is best to operate the module with the highest allowable setting to allow for upward drift of the AC line & DC bus during unloaded conditions*
- *Drive over-voltage trip level must be taken into account*
- *Removing the enable forces the brake to ignore any over-voltage conditions when the drive is not running*

For PW-NC Models the factory setting of JP4 should not be changed unless an extremely high DC bus is seen or expected, and the external enable command is not used.

Master - Slave Jumper: When the JP7 jumper is in the upward position, the braking module is in the Slave mode. If the JP7 jumper is in the downward position, the braking module is in the Master mode. When a single module is used it must be in the Master mode. If multiple modules are needed, ***only one unit can be in the Master mode while all other modules are in the Slave mode.***

Fault Contact Jumper: When the module is operating properly and JP8 is in the upward position the fault contact is Normally Closed (NC). When JP8 is in the downward position the fault contact is Normally Open (NO). Contacts change state only during a fault condition and do not change state when the module is powered ON or OFF. If equipped with the standard crowbar circuitry and the IGBT fails, the fuse will be purposefully blown and the fault contact will never reset.

Figure 5: Drive DC BUS Power Connections

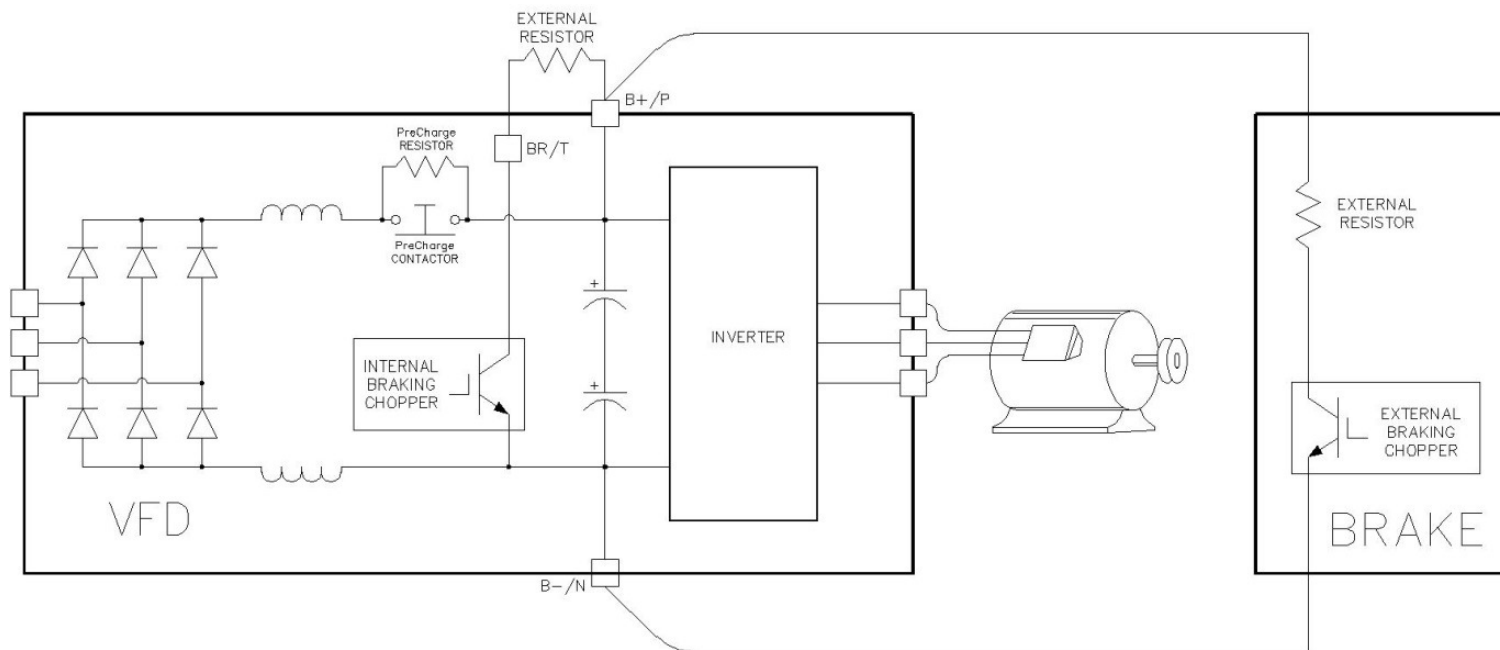

Internal/External Chopper: In the example above, the internal and external chopper connections are shown. ***Both should never be used at the same time.*** An external chopper is needed when a drives internal chopper cannot support the desired duty cycle, or when the drive has no internal chopper transistor.

Wiring Notes: All DC power wiring should be connected DIRECTLY to the DC bus caps of the drive as shown in Figure 5. Connecting upstream of contactor or line chokes may cause an overvoltage or high frequency switching condition and possibly damage the brake and drive.

Figure 6: Power Connections for a Single Braking Module

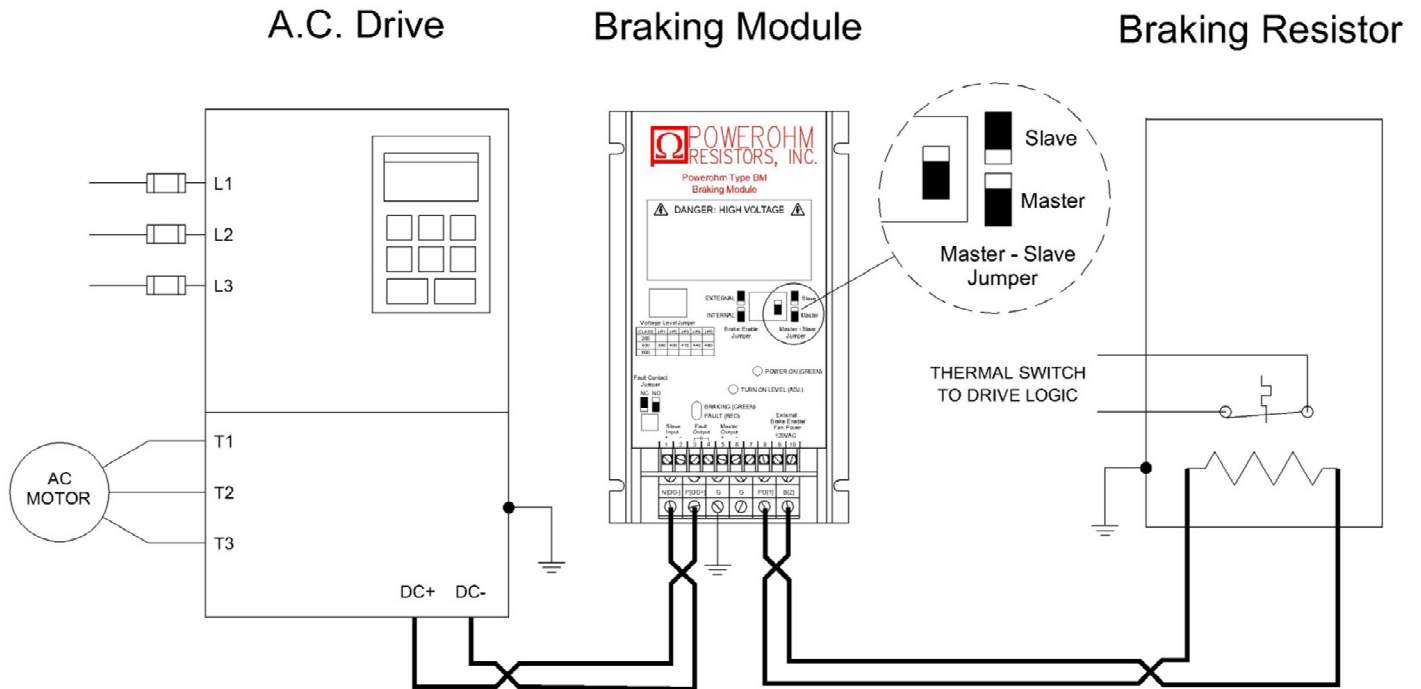

Master - Slave Jumper Settings: In the example above, the braking module is set as the Master (JP7 is the downward position).

Wiring Notes: All DC power wiring between the drive, braking module and braking resistor should be twisted (if possible) and run separate from all control wiring.

Figure 7: Power Connections for Multiple Braking Modules

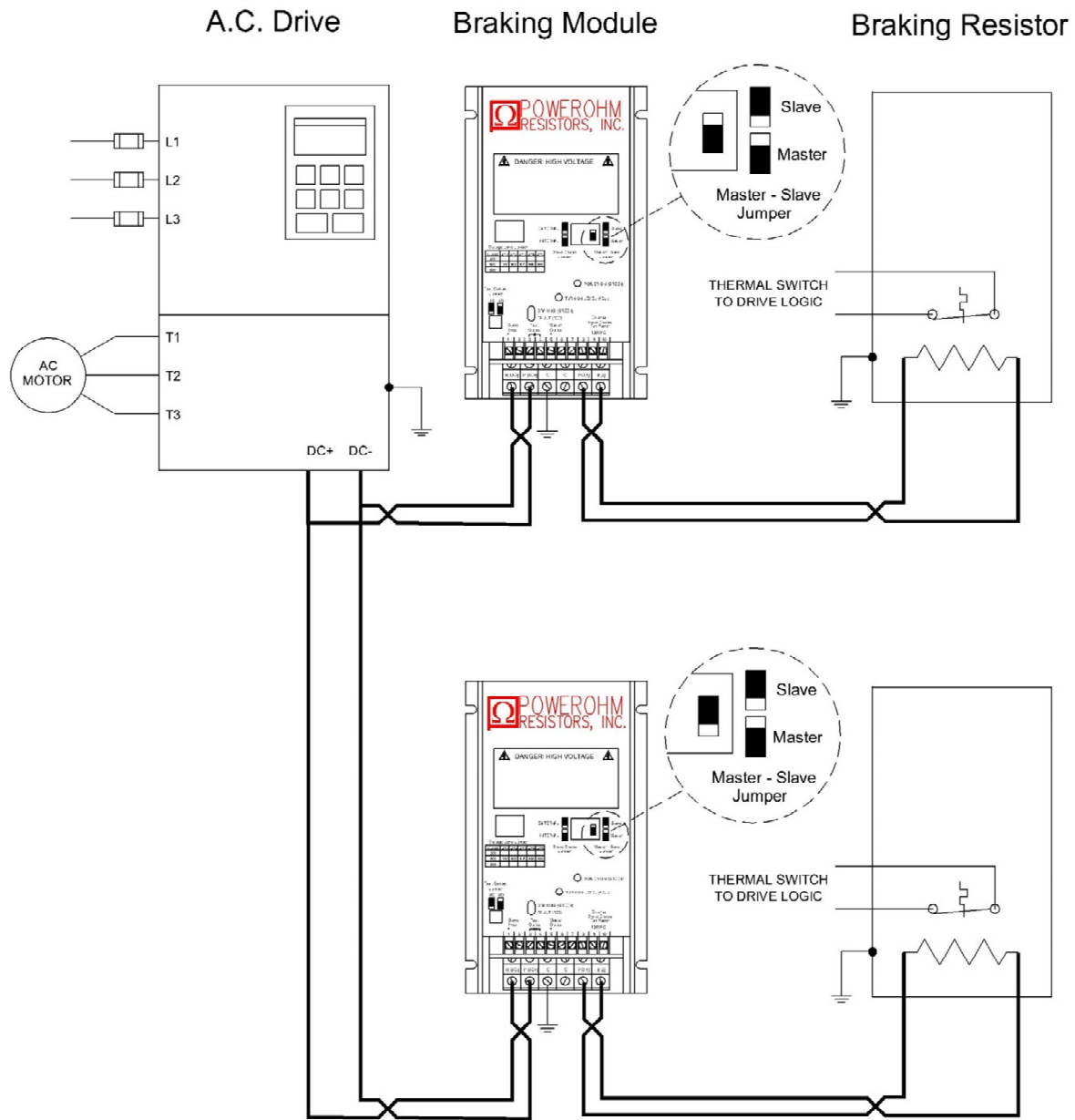

Master - Slave Jumper Settings: In the example above, the top braking module is set as the Master (JP7 is the downward position) and the lower module is in Slave Mode (JP7 is in the upward position).

- Damage will occur if both jumpers are set for master with signal wires connected

Wiring Notes: All DC power wiring between the drive, braking module and braking resistor should be twisted (if possible) and run separate from all control wiring.

Figure 8: Control Connections for Multiple Braking Modules

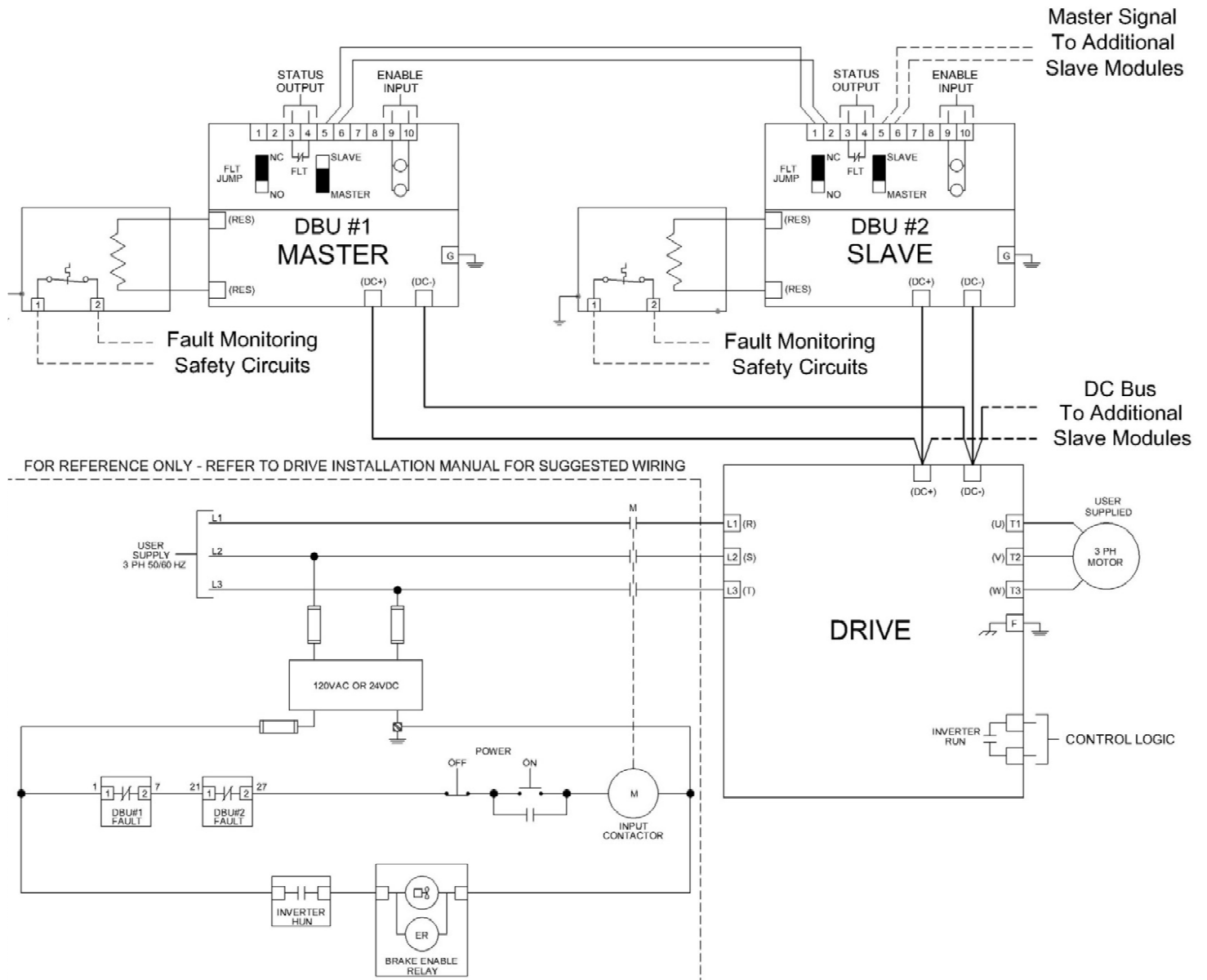

Master - Slave Jumper Settings: In the example above, the top braking module is set as the Master (JP7 is the downward position) and the lower two modules are in Slave Mode (JP7 is in the upward position).

Wiring Notes: All Control wiring between the drive, braking module and braking resistor must be twisted and run separate from all Power wiring.

PRELIMINARY:

- Ensure the DC bus connections are proper polarity.
- Make sure that braking module voltage rating is equivalent to the drive and that all voltage selection jumpers are in the proper positions.
- Ensure drives internal braking circuits are disabled
- Ensure the enable jumper is set according to your application. JP6 is Factory set for an **external** enable voltage at control board terminals 9 & 10 for the PWx115NC & 150NC. THE BRAKE MODULE WILL NOT TURN ON IF THE MODULE IS NOT ENABLED
- To see the internal LEDs it will be necessary to position yourself directly in front of the module front cover looking into the cover viewing hole.
- It is good practice to monitor the DC bus under stopped and braking conditions, making sure the braking setpoint is not too close to the nominal unloaded DC bus voltage.
- In order to best capture the peak voltage use an oscilloscope or a meter with a peak hold function.

POWER UP: As the DC bus pre-charges the green POWER ON LED illuminates indicating that DC bus voltage is properly applied to the DC- and DC+ power connections. At this time the braking and fault LEDs should be OFF. Note unloaded DC bus level.

BRAKING CYCLE: Start the drive and run the motor unloaded. Stop the drive quickly and monitor the green BRAKE LED. The LED will flash on, the heavier the braking, the more it flashes. Load motor, then start and stop drive and again monitor braking LED. Note DC bus level during the peak of the braking cycle. If the unloaded nominal DC bus is within 10% of the peak DC Bus during braking, consider increasing the braking voltage threshold or using a drive contact to disable the brake while drive is idle.

DECELERATION: While under full load slowly decrease drive decel time while monitoring DC bus level. Decrease decel time as process allows until DC bus rises near the drive high bus trip level. Now increase decel time back to a level allowing a comfortable amount of headroom to prevent nuisance overvoltage trips. (If the drive trips on overvoltage easily or you can't stop the drive fast enough, the brake module may be undersized)

DUTY CYCLE: While under full load increase the duty cycle while monitoring the DC bus level and module resistors. If the resistors are glowing at the end of each braking cycle the duty cycle should be decreased. (Although the resistors can take extreme temperature they will last longer if they are not stressed to the point of glowing on every cycle)

FAULT: With the brake module sized correctly and the proper decel time and duty cycle settings the fault LED should never turn ON. If the fault LED turns on and the brake module is hot, simply allow time to cool, and either increase the decel time or decrease the duty cycle. Ensure the cooling fan has voltage and is operating properly. (115 & 150 amp models)

CAUTION: NEVER perform any maintenance while power is present. ALWAYS be sure to double check for safe voltage levels by measuring the DC bus input as well as any external control or status signals before working on equipment.

Monthly; Check that the Green power LED is ON, and the Red Fault LED is OFF. If the brake module has an internal fan, check that it is blowing air.

Yearly; Check the module circuit boards for buildup of dust, debris, or moisture. Check the cooling fan and heatsink for any buildup. High voltages exist within the module and the buildup of dust, debris, and moisture can contribute to arcing and equipment damage. Take corrective action as necessary to keep the module clean.

If cleaning is needed remove power from system and allow time for all voltages to drain to safe levels. Blow the debris out with clean dry air. Blow off any debris that exists on the circuit boards.

NORMAL LED INDICATORS

The PowerOhm Series PW-NC Braking Module has three LED indicators that allow the user to verify the following:

POWER ON: An illuminated green LED indicates that DC bus voltage is applied to the DC- and DC+ power connections.

BRAKING: An illuminated or flashing green LED indicates that the module is braking.

FAULT: An illuminated red LED indicates that the module has over-heated **OR** the internal braking transistor has failed shorted. If the module overheated the fault LED will eventually turn off after a cooling period of no less than 2 minutes with fan running and no longer than 30 minutes without fan running.

TURN ON LEVEL (ADJ.)

The TURN ON LEVEL adjusts at what DC bus voltage the braking module will turn ON and activate the braking resistor. This level is calibrated at the factory and should never be adjusted in the field by non-factory personnel. Generally speaking, it is best to operate the module with the highest allowable setting to allow for upward drift of the AC line during lightly loaded conditions.

Control board Jumpers JP1 – JP5 are a coarse adjustment and change the setpoint by approximately 4-5% for each position. If changing jumper positions the system power should be turned off and insulated needle nose pliers should be used.

ABNORMAL SYMPTOMS

- Before removing equipment covers or making any changes in jumper positions or adjustments, power down equipment and wait for DC bus to drop to safe levels. Always use an insulated screwdriver or insulated pliers when making jumper changes or adjustments
- Follow these steps and make note of indications before calling for help. Have unit model and serial number ready to aid PowerOhm in troubleshooting

GREEN POWER LED IS NOT ON

- Check for DC bus at input of brake chopper module
- If new installation check for loose wires or connections on control board
- If DC bus is present and all connections seem to be normal, replace module

BRAKING LED NEVER TURNS ON

- Check for proper voltage rating of control board
- Check for proper positioning of coarse voltage adjust jumpers
- Check enable jumper position and enable voltage at TB1-9 & 10 of control board
- Monitor DC bus and decrease decel time until DC bus rises enough to cause braking
- If all the above are OK, using insulated needle nose pliers move coarse voltage adjust jumper to the left one position and retry
- If moving jumper to the left three positions does not result in brake module turning ON, replace module

BRAKING LED FLICKERS

- During light duty braking or at the end of a braking cycle it is normal for the LED to flicker some
- If the LED flickers when the Drive is idle there may be excessive noise on the DC bus from other equipment, a higher than expected AC line level, or high harmonics on the incoming voltage
- If the LED flickers when the drive is running normal load (not braking) there may be excessive common mode noise on the DC bus and addition DC bus filtering may be needed

BRAKING LED NEVER TURNS OFF / RESISTOR OVERHEATS

- Check for proper voltage rating of control board and jumper positions
- Ensure the brake module is connected DIRECTLY to the drive DC bus cap bank. Connecting up stream of the precharge circuits may result in high peak voltages that can turn on the brake module
- Check actual system AC line voltage for high harmonic content (high peak to RMS ratio) or for excessive noise spikes as this may cause an unusually high DC bus level on an unloaded drive
- If the above are OK, power down and using insulated needle nose pliers move coarse voltage adjust jumper to the right one position and retry
- If moving jumper to the right 3 positions does not result in brake module turning off, or the jumper cannot be moved further to the right, continue with next step
- Using an insulated screwdriver turn the adjustment pot CW. If the control board is working properly, and the DC bus voltage is normal, at some point the braking LED should turn off. This indicates the unit has been tampered with and should be re-calibrated by qualified personnel at the PowerOhm facility
- If none of the above steps solves the problem, replace module

BRAKING MODULE GETS HOT

- It is normal for brake modules to generate heat during heavy duty operation
- Check load and duty cycle to make sure module is sized correctly
- If the module overheats the fault LED will turn on and the output fault contact will change states
- If IGBT is shorted the electronics module will not get hot, but the resistor will

FAULT LED IS ON

- Check unit for heatsink overheating and allow time to cool
- Check for proper sizing of brake module as overheating indicates the module is running beyond its capacity
 - a. Reduce the duty cycle or increase the decel time
 - b. Use a higher rated braking module
- Confirm the 2 position thermostat plug at top of control board is seated properly
- If the above are OK, replace module

MASTER SLAVE SYSTEM DOES NOT WORK PROPERLY

- Check position of master slave jumpers on each module. Damage will occur if both jumpers are set for master with signal wires connected.
- Make sure wiring between master and slaves is correct at TB1 of the control board
- Ensure the system is sized properly
- Monitor Braking LED on all modules. If master braking LED turns on but any slave does not, and wiring is correct, replace slave module(s). If master braking LED never turns on follow steps for “Braking LED never turns on”

NOTES

“PW-NC” Series Manual Rev. 2014-03-18

