

POWEROHM INSTALLATION MANUAL FOR “PK” SERIES BRAKING MODULES



IMPORTANT: These instructions should be read thoroughly before installation. All warnings and precautions should be observed for both personal safety and for proper equipment performance and longevity. Failure to follow these instructions could result in equipment failure and/or serious injury to personnel. Braking modules contain lethal voltages when connected to the inverter. It is very important to remove power to the inverter before installing or servicing this unit. Always allow adequate time (approximately 5 minutes) after removing power before touching any components. The POWER ON LED must be completely out and the resistor elements cool before servicing the unit

TABLE OF CONTENTS

- Page 2: Table of Contents for Manual “PK” Series Manual Rev. 2014-03-18
- Page 3: Product Overview and Inspection
- Page 4: Environmental Conditions and Electrical Ratings
- Page 5: Equipment Installation
- Page 6: Dimensions and Weight for PKx005 and PKx010
- Page 7: Dimensions and Weight for PKx050
- Page 8: Wire Recommendations
- Page 9: Wire Sizing
- Page 10: Power Connections for PKx005 and PKx010
- Page 11: Power Connections for PKx050
- Page 12: Control Connections
- Page 13: Module Set Up - Jumper Descriptions and Locations
- Page 14: Module Set Up – Factory Jumper Settings
- Page 15: Module Set Up – Voltage Selection and Master/Slave Jumpers
- Page 16: System Integration - Drive DC Bus Connections
- Page 17: System Integration - Single Module Power Connections
- Page 18: System Integration - Master / Slave Power Connections
- Page 19: System Integration - Master / Slave Control Connections
- Page 20: Start Up
- Page 21: Start Up
- Page 22: Troubleshooting
- Page 23: Troubleshooting
- Page 24: Troubleshooting
- Page 25: Troubleshooting

PRODUCT OVERVIEW

AC variable frequency drives are commonly used with various types of motors to form reliable variable speed drive systems. Problems with these drive systems can occur when an application requires a deceleration rate faster than what can be managed by the drive alone, or when motor speeds exceed the synchronous speed set by the output frequency of the drive (which is called an overhauling load condition). Both of these conditions create regenerated power which flows from the motor back into the drive, causing its DC Bus to rise. To manage the regenerated power and avoid shutting the drive down due to an over-voltage trip, this power must be dissipated by an external braking resistor.

PowerOhm Series PK Braking Modules can be used in conjunction with any AC drive to monitor the DC bus of the drive and **activate an internal braking resistor** as needed not only to avoid over-voltage trips, but to greatly improve the performance of the drive system. The use of Braking Modules with the included braking resistor increases the braking torque capability of a variable frequency drive, allowing faster and more controlled deceleration times.

To accommodate system horsepower requirements beyond the capability of a single Module, the Modules are all Master/Slave programmable. This allows an arrangement of multiple Modules to effectively function as a single higher rated module.

INSPECTION UPON RECEIPT

Upon receipt of your PowerOhm Braking Module, be sure to carefully unpack the module and inspect the unit carefully for any shipping damage. The module contains electronics that can be damaged by static electricity, so handle in accordance with industry standards. Check for loose, broken or otherwise damaged parts due to shipping. Report any shipping damage immediately to the freight carrier. Be sure to verify that the part number and ratings listed on the nameplate match the order specification and the capabilities of the drive system. ***The ratings listed on the nameplate are critical – installing and energizing the incorrect part number could damage the braking module and/or the drive!***

ENVIRONMENTAL CONDITIONS

The PowerOhm Series PK Braking Module should be installed in an environment protected from moisture and excessive dust. Dust buildup can reduce the electrical insulation characteristics of the unit and moisture can cause arcing or shorting. Air must be free of combustible gases and corrosive vapors.

Ambient Temperature Range: -10°C to 40°C

Maximum Altitude: 3300 feet (1000m)

Maximum Vibration: 10 to 20Hz, 32ft/sec/sec; 20 to 50Hz, 6.5 ft/sec/sec

ELECTRICAL RATINGS

The PowerOhm Series PK Braking Modules have their own internal braking resistors making installation simpler. They are available in three different voltage classes including 240, 480 and 600 volts. Maximum Ratings are shown in Table 1.

TABLE 1: General Specifications for Series PK Braking Modules

Powerohm Part No.	Nominal AC Line Voltage	Resistance Value in Ohms	Turn ON Voltage	Typical Wattage Dissipation	Internal Fuse Rating
PKA005	240	28	375vdc	667	FWP70-10
PKA010	240	13.2	375vdc	1650	FWP70-15
PKB005	480	108	750vdc	1500	FWP70-10
PKB010	480	52.7	750vdc	2063	FWP70-15
PKB050	480	10.5	750vdc	7000	FWP70-40
PKC005	600	160	940vdc	1500	FWP70-10
PKC010	600	80	940vdc	2063	FWP70-15
PKC050	600	15.8	940vdc	8000	FWP70-40

Fusing is closely coordinated with the PowerOhm Crowbar circuits. ONLY 700vdc rated FWP, A70QS, or equivalent semiconductor fuses should be used.

EQUIPMENT INSTALLATION

The PowerOhm Series PK Braking Module should be installed on a low vibration surface that is non-flammable.

Check for physical damage and for loose wires or plugs after installation.

Attention: Installation and removal of this equipment should be done by qualified personnel only. Equipment must be installed in accordance with all applicable national and local electrical codes and regulations.

MOUNTING REQUIREMENTS

To allow proper cooling, it is very important to install convection cooled PowerOhm braking modules in the vertical position (see Figure 1). A convection cooled model is simply a unit without a factory installed cooling fan.

Braking modules should have at least 6 inches clearance on all sides to allow for adequate cooling. More distance may be required to keep brake module heat from affecting nearby components. Interconnecting wiring should not exceed 5 feet between modules.

FIGURE 1: Mounting Position for Convection Cooled Modules

CORRECT

INCORRECT

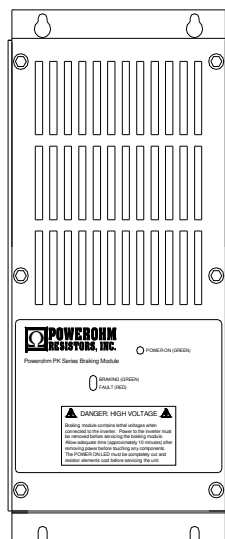

UP

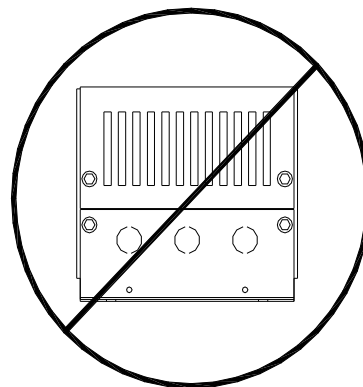

DIMENSIONS AND WEIGHT

The PowerOhm Series PK Braking Modules shown below in Figure 2a and Figure 2b includes the dimensions of both units

FIGURE 2a: Braking Module Dimensions for Part Numbers PKA005, PKA010, PKB005, PKB010, PKC005 and PKC010.

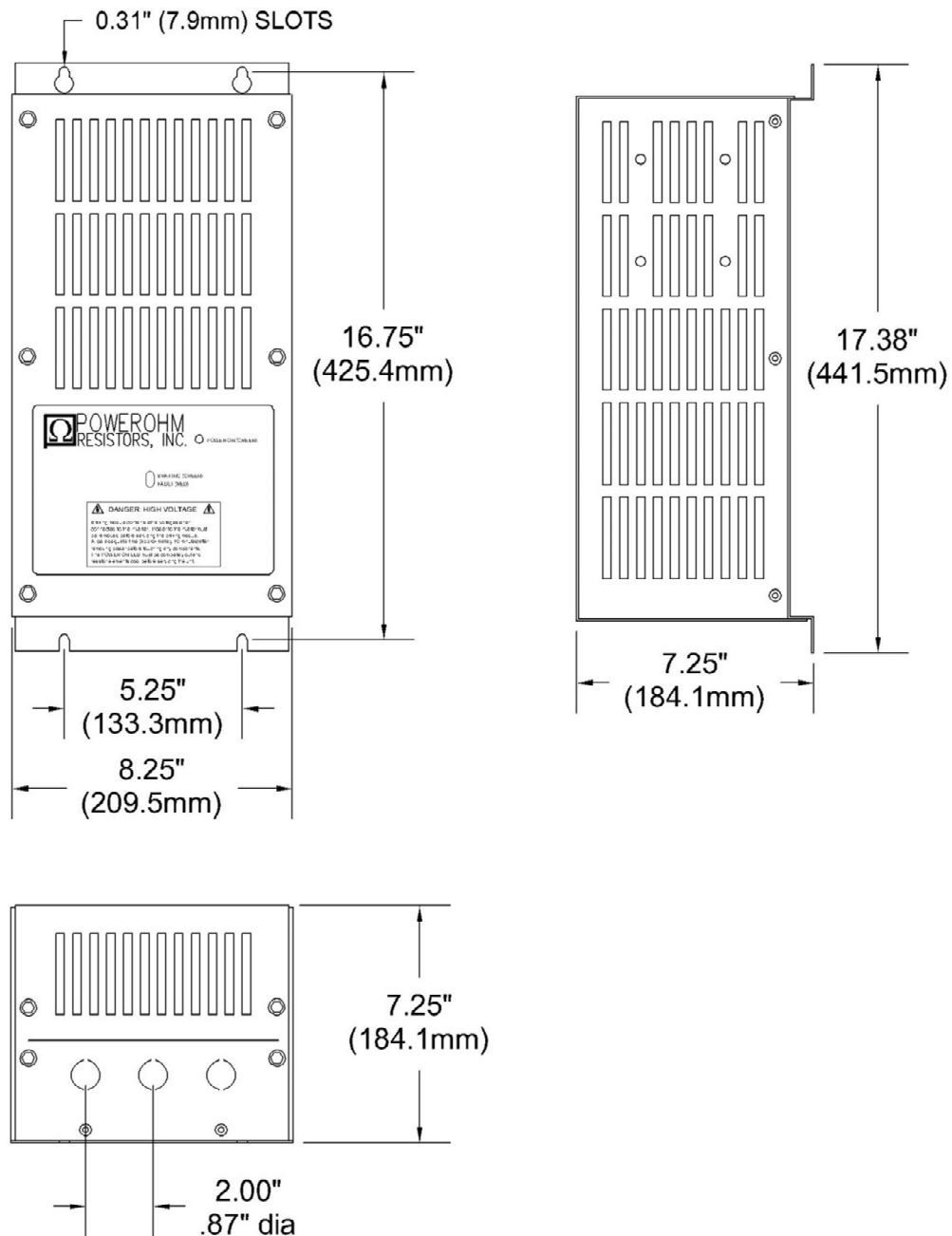

Weight: The weight is approximately 14 lbs.

**FIGURE 2b: Braking Module Dimensions for Part Numbers
PKB050 & PKC050.**

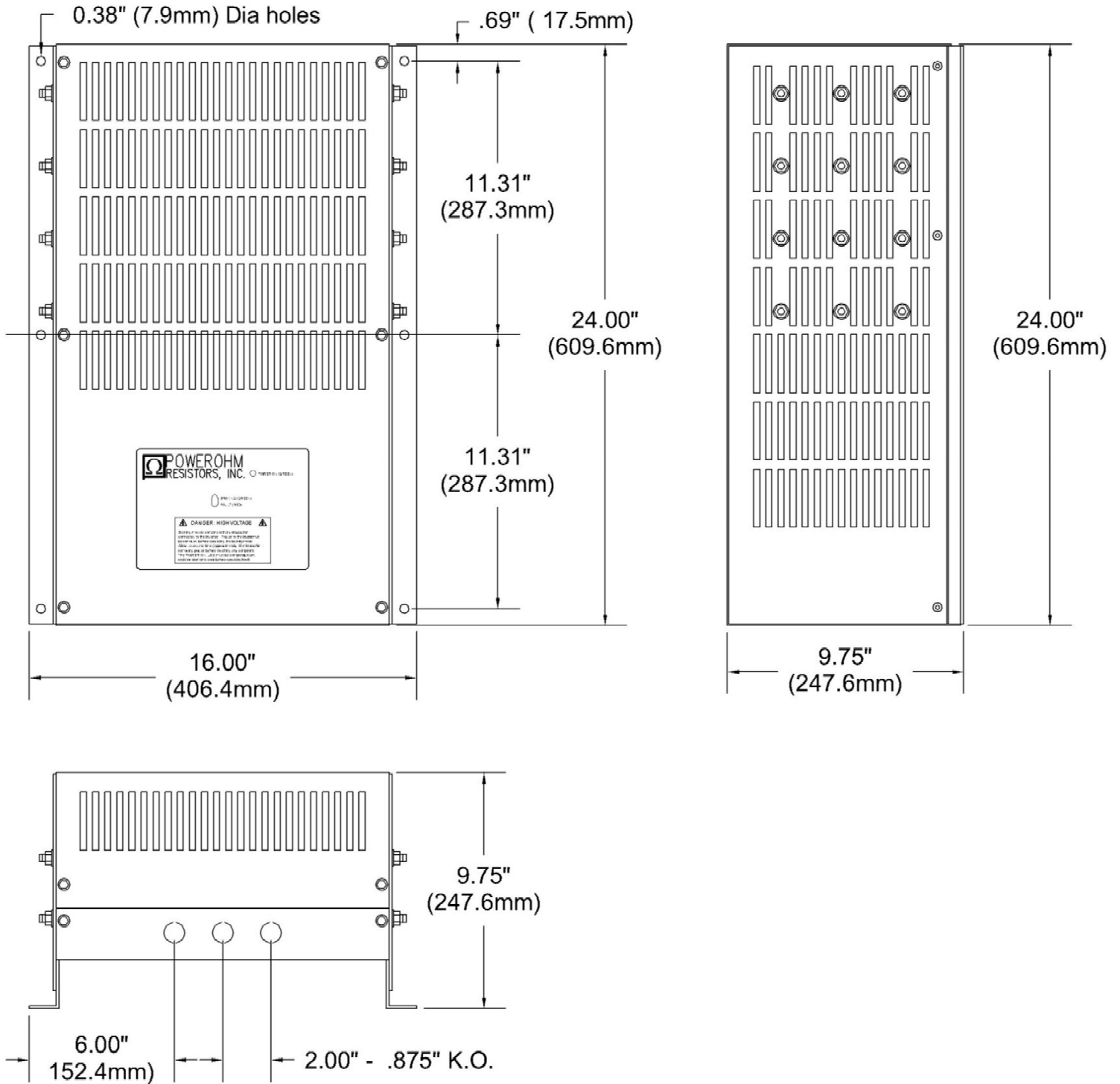

Weight: The weight is approximately 45 lbs.

WIRING RECOMMENDATIONS

It is recommended that the AC drive manual and braking module instructions and any other pertinent documentation be thoroughly reviewed before proceeding. Note that control and power wiring should be separated to avoid electrical noise and interference problems. The wiring between the drive and braking module should not exceed 15 feet.

Important: Always properly ground each component to earth For best noise immunity connect Braking Module chassis ground directly to AC Drive Module Power earth ground.

FIGURE 3: Wiring Lengths Between Drive System Components

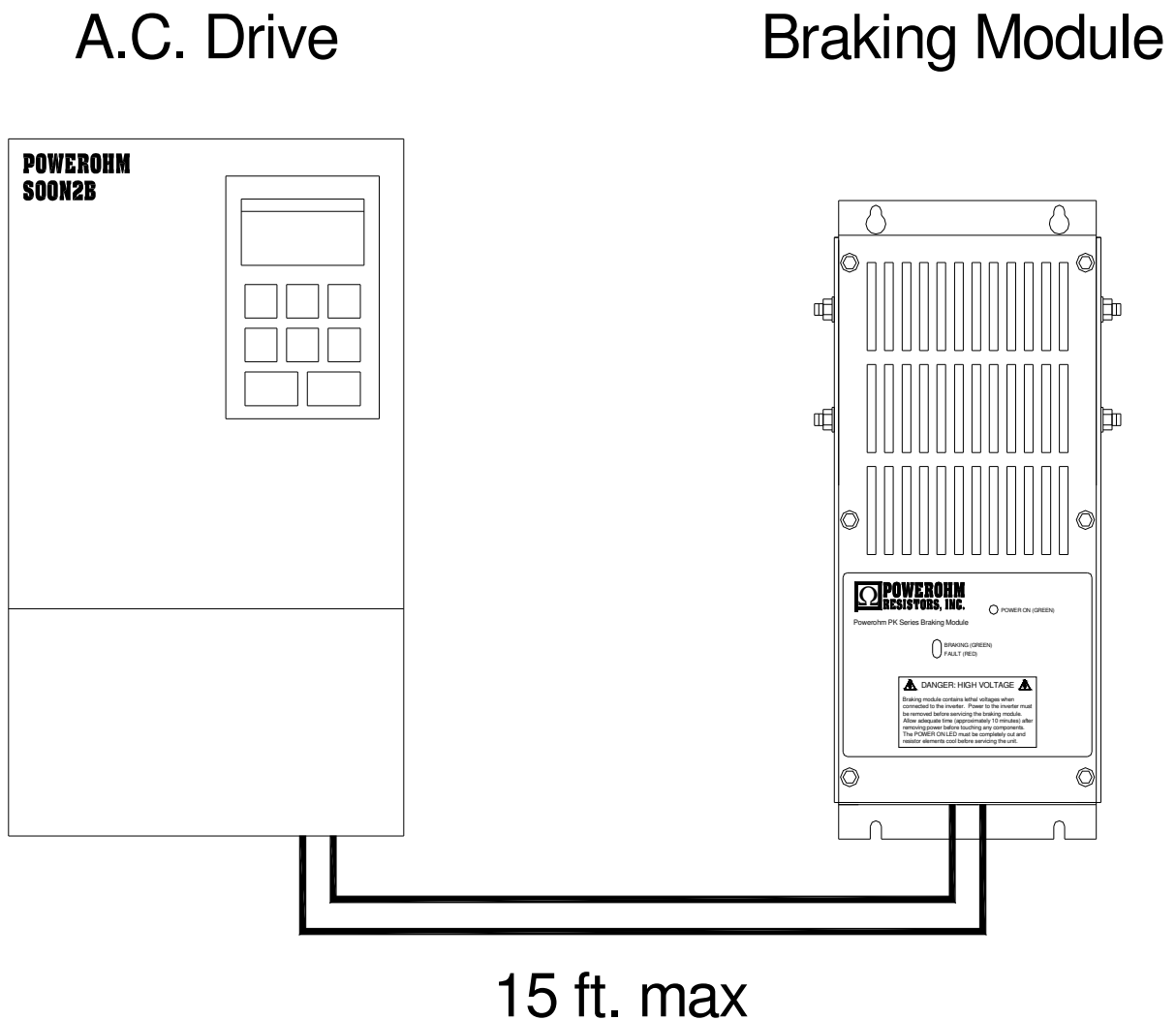

WIRE SIZING

Reference Table 2 for suggested minimum wire sizes only. Keep in mind the duty cycle rating greatly affects the minimum wire size needed.

TABLE 2: Wire Sizing for Power Interconnections

Motor HP at 10% Duty Cycle			WIRE SIZE
240VAC	480VAC	600VAC	
1HP to 50HP	1HP to 75HP	1HP to 75HP	10 AWG
60HP to 100HP	100HP to 150HP	100HP to 150HP	8 AWG
N/A	200HP-250HP	200HP-250HP	6AWG
Motor HP at 30% Duty Cycle			WIRE SIZE
240VAC	480VAC	600VAC	
1HP to 30HP	1HP to 40HP	1HP to 40HP	10 AWG
40HP to 75HP	50HP to 75HP	50HP to 75HP	8 AWG
100HP	100HP to 250HP	100HP to 250HP	6 AWG

Note: 18 AWG wire is sufficient for all control and signal wiring.

ATTENTION: The National Electric Code (NEC) and local regulations govern the installation and wiring of electrical equipment such as braking resistors and modules. DC power wiring, AC power wiring, control wiring and conduit must be installed in accordance with all applicable codes and regulations.

POWER CONNECTIONS

The PowerOhm Series PK Braking Module features a total of 2 power connections and an earth ground Terminal location and size is dependent on the current capacity of the model. See reference tables 3a, and 3b for a description of each terminal's function, torque, type of connection and wire size.

TABLE 3a: Description of Power Connections for PKx005 and PKx010

Terminal Number	Terminal Description	Maximum Torque (lb-in)	Connection Type	Maximum Wire Size
1	DC Bus Negative	11	#6 spade lug / bare wire	12 awg
2	N/A	N/A	N/A	N/A
3	N/A	N/A	N/A	N/A
4	DC Bus Positive	11	#6 spade lug / bare wire	12 awg
	Power Earth Ground	15	#10 Ring Lug	12 awg

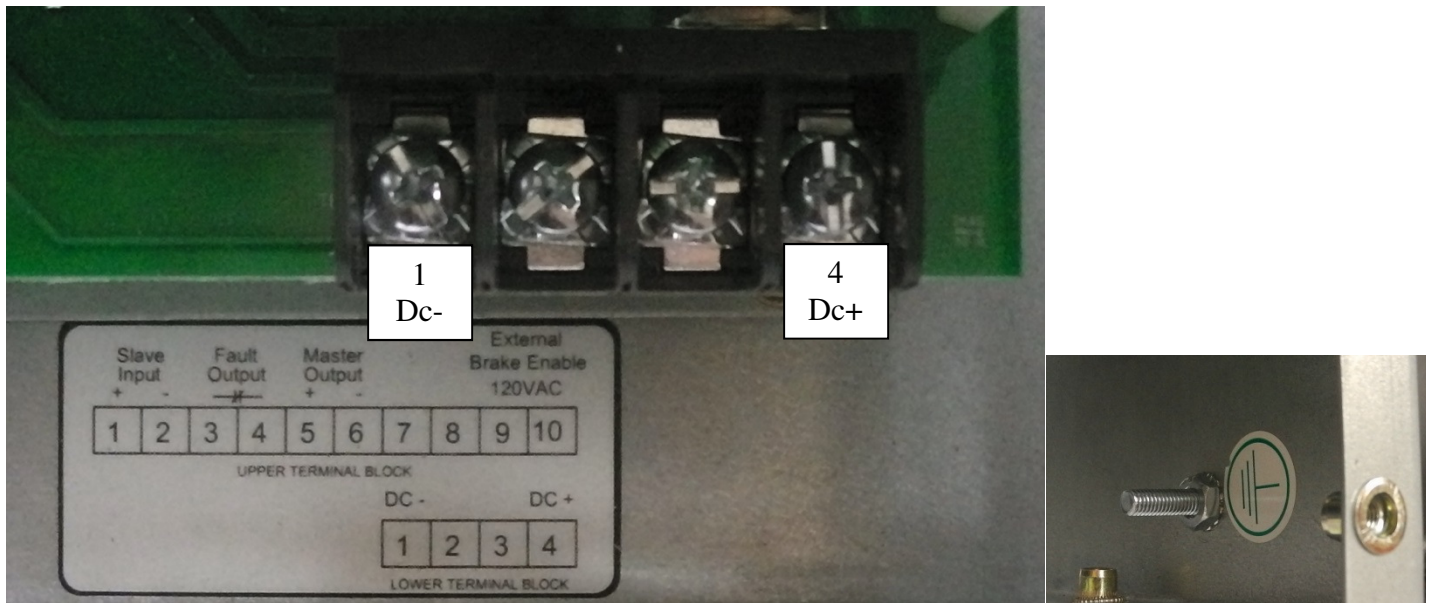

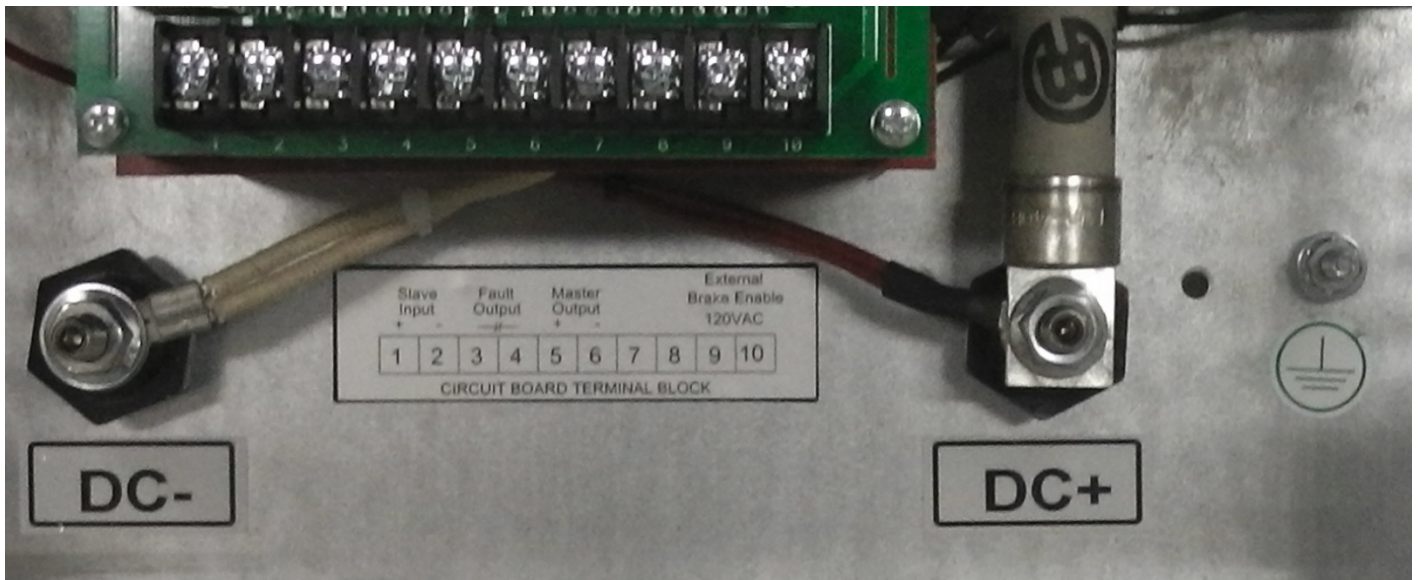

TABLE 3b: Description of Power Connections for PKx050

Terminal Number	Terminal Description	Maximum Torque (lb-in)	Connection Type	Maximum Wire Size
DC -	DC Bus Negative	50	5/16" ring lug	4 awg
DC +	DC Bus Positive	50	5/16" ring lug	4 awg
	Power Earth Ground	15	#10 Ring Lug	6 awg



The PowerOhm Series PK Braking Module features a 10-position terminal block for all signal and control wiring. All terminations on the block can accept bare wire or fork lugs for a #6 screw. Reference Table 4 for a description of each terminal.

TABLE 4: Description of Control Connections for All PK Models

Terminal Number	Terminal Description	Electrical Ratings	Maximum Torque (lb-in)
1	Slave Input Pulse (Positive)	24vdc @ 10ma	7
2	Slave Input Pulse (Negative)	24vdc @ 10ma	7
3	Fault Contact Output (NO or NC)	125vac/24vdc @ .5a	7
4	Fault Contact Output (NO or NC)	125vac/24vdc @ .5a	7
5	Master Output Pulse (Positive)	24vdc @ 50ma	7
6	Master Output Pulse i (Negative)	24vdc @ 50ma	7
7	Non-functioning termination	N/A	7
8	Non-functioning termination	N/A	7
9	120VAC external Enable & Fan	.5a @ 125vac	7
10	120VAC external Enable & Fan	.5a @ 125vac	7

Note: 18 AWG wire is sufficient for all control and signal wiring

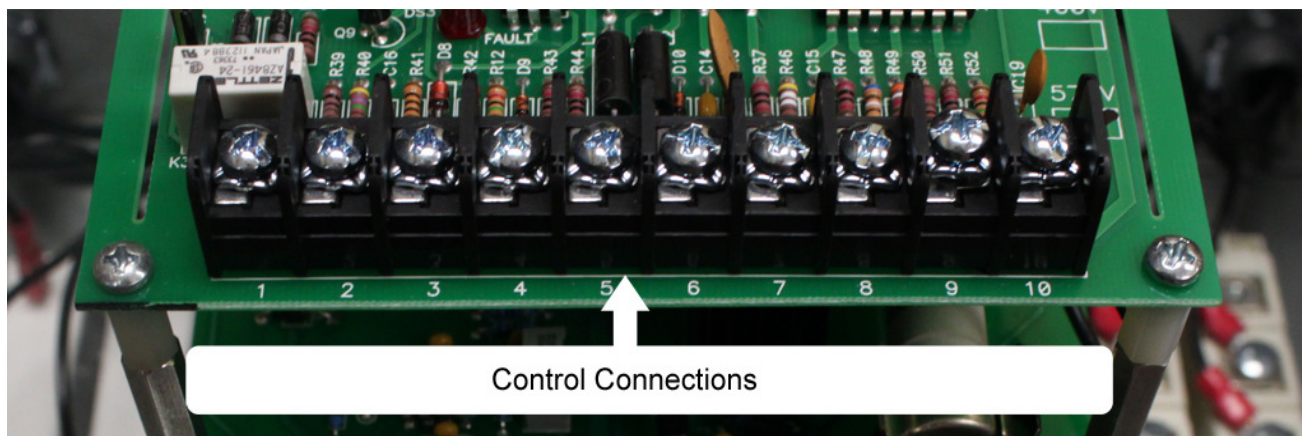

The PowerOhm Series PK Braking Module has several jumper settings that are accessible on the main circuit board. The front cover has to be removed to change the jumper settings.

Warning: Do not make jumper changes while power is applied! Change as required only after power is removed and the green power indicator is off! Use insulated tools when changing jumper positions.

TABLE 5: Description of Jumper Settings

Jumpers	Jumper Description
JP1-JP5	Set to match the actual on site AC line voltage
JP6	Selects Internal or External Brake Enable
JP7	Selects a Master or Slave configuration
JP8	Selects a NC or NO Fault contact.

FIGURE 4a: Control Board Jumper Locations

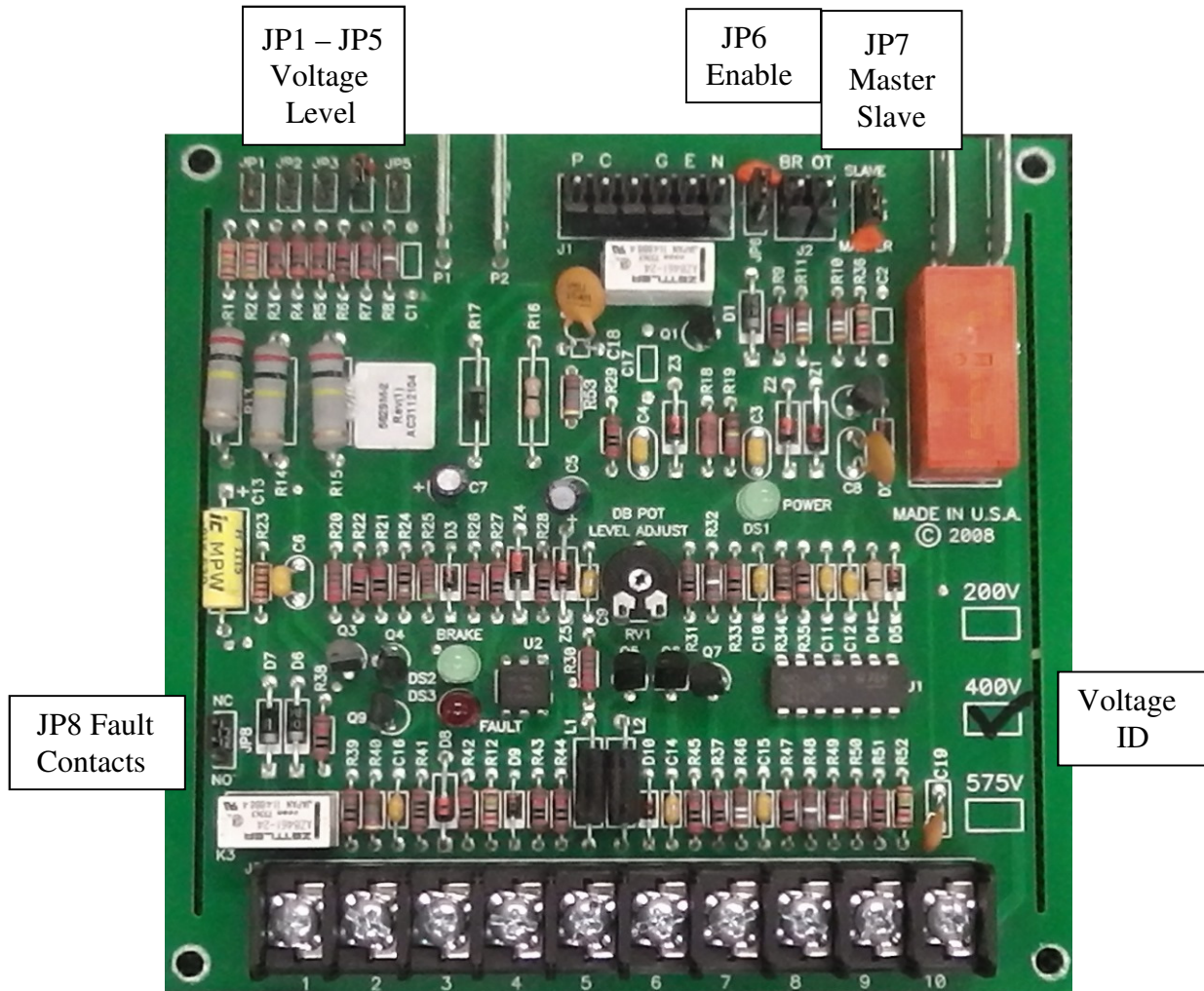
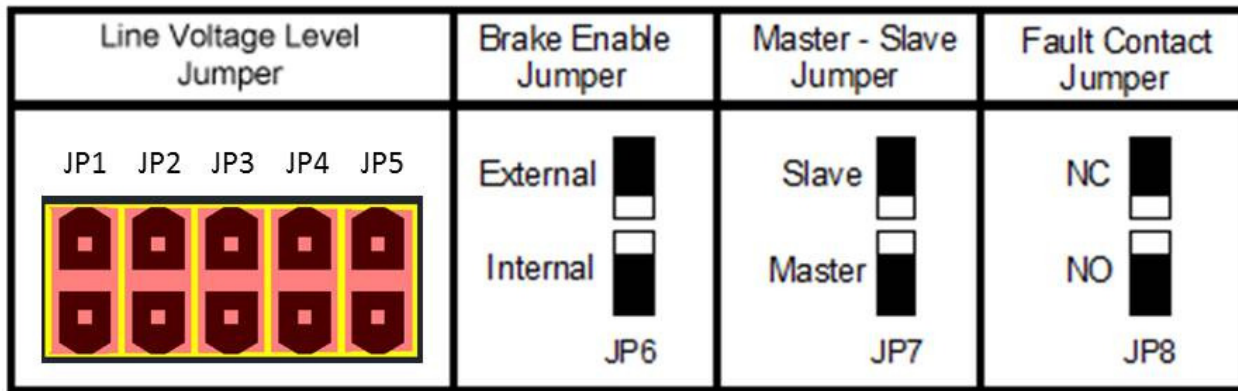

FIGURE 4b: Control Board Jumper Positions



CAUTION: Do not make jumper changes while power is applied! Change as required only when power is removed and the green power indicator is off! Use insulated tools when changing jumper positions.

Brake Enable Jumper: JP6 selects between internal enable or external enable modes

Internal (Automatic): When the JP6 jumper is in the downward position, the Brake is Enabled automatically whenever system DC Bus voltage is applied. Note that PK050 models must still have voltage at terminals 9 & 10 for the cooling fan.

External: When the JP6 jumper is in the upward position, the Brake is Enabled ONLY when voltage is applied to control terminals 9 and 10. This position is recommended so the Brake can be disabled when the drive is not running.

- The PKx050 REQUIRES voltage at terminals 9 & 10 to run the cooling fan regardless of the position of JP6

TABLE 6: Factory Installed Enable Jumper Settings

PowerOhm Part No.	Line Voltages	JP6 Brake Enable	JP7 Master Slave	JP8 Fault Contact
PKx-005	200-600	Internal	Master	NC
PKx-010		Internal		
PKx-050		External		

CAUTION: If the Enable Jumper is set to INTERNAL with power applied to an idle drive, the bus voltage can reach a value high enough to turn on the braking module, potentially causing the braking resistor to over-heat.

Line Voltage Level Jumpers: The voltage ID box in fig 4a indicates which voltage class the control board is set up for and the voltage class determines the DC threshold level expected for each jumper position. PK series braking modules are calibrated to the DC voltages shown in the JP4 column in table 7, with JP4 ON. Moving the jumper to another position changes the DC turn on thresholds as shown in table 7.

TABLE 7: DC Voltage turn on voltages for PK models

Voltage Class	JP1	JP2	JP3	JP4	JP5
200vac	323vdc	339vdc	355vdc	375vdc	391vdc
400vac	646vdc	677vdc	709vdc	750vdc	782vdc
600vac	813vdc	853vdc	892vdc	940vdc	980vdc

If the actual drive input AC Line voltage differs from the factory default setting considerably, and the external enable command is not used, it may be necessary to change the jumper setting to match the power source.

- *Generally speaking, it is best to operate the module with the highest allowable setting to allow for upward drift of the AC line & DC bus during unloaded conditions*
- *Drive over-voltage trip level and reactions to bus rise must be taken into account*
- *Removing the enable forces the brake to ignore any over-voltage conditions when the drive is not running*

For PK Models the factory setting of JP4 should not be changed unless an extremely high DC bus is seen or expected, and the external enable command is not used.

Master - Slave Jumper: When the JP7 jumper is in the upward position, the braking module is in the Slave mode. If the JP7 jumper is in the downward position, the braking module is in the Master mode. When a single module is used it must be in the Master mode. If multiple modules are needed, only one unit can be in the Master mode while all other modules are in the Slave mode.

Fault Contact Jumper: When the module is operating properly and JP8 is in the upward position the fault contact is Normally Closed (NC). When JP8 is in the downward position the fault contact is Normally Open (NO). Contacts change state only during a fault condition and do not change state when the module is powered ON or OFF. If equipped with the standard crowbar circuitry and the IGBT fails, the fuse will be purposefully blown and the fault contact will never reset.



FIGURE 5: Drive DC BUS Power Connections

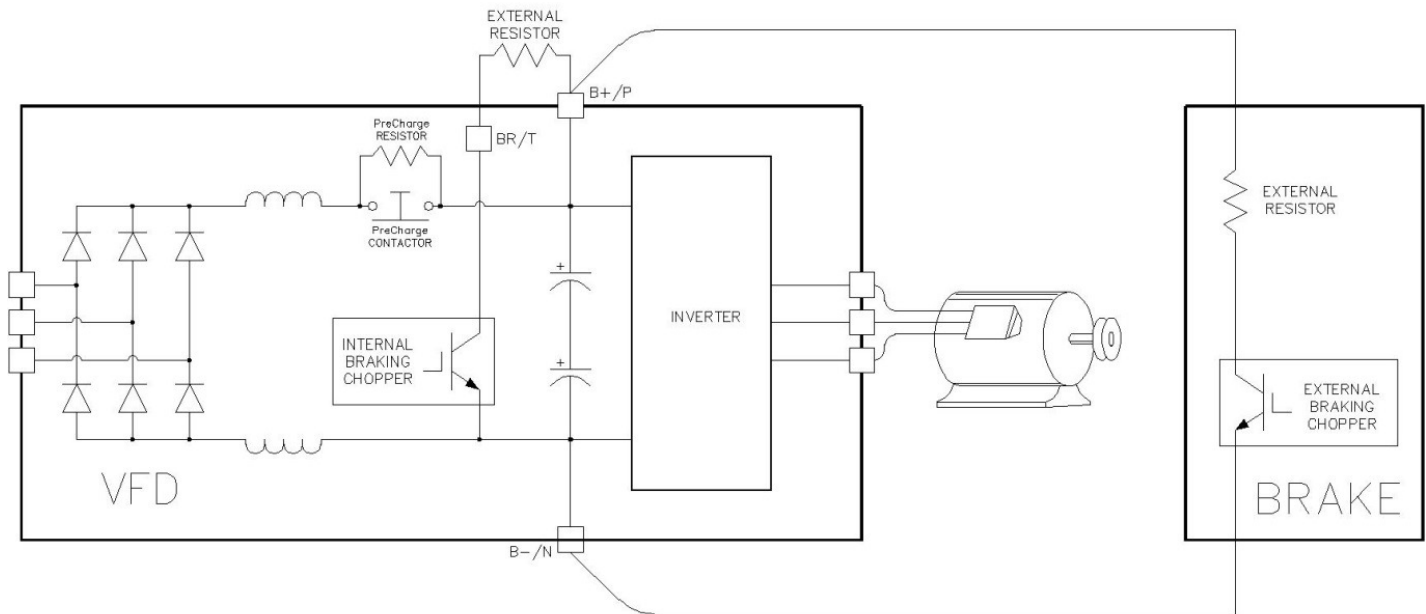

Internal/External Chopper: In the example above, the internal and external chopper connections are shown. Both should never be used at the same time. An external chopper is needed when a drives internal chopper cannot support the desired duty cycle, or when the drive has no internal chopper transistor.

Wiring Notes: All DC power wiring should be connected DIRECTLY to the DC bus caps of the drive as shown in Figure 5. Connecting upstream of contactor or line chokes may cause an overvoltage or high frequency switching condition and possible damage the brake and drive.

FIGURE 6: Power Connections for a Single Braking Module

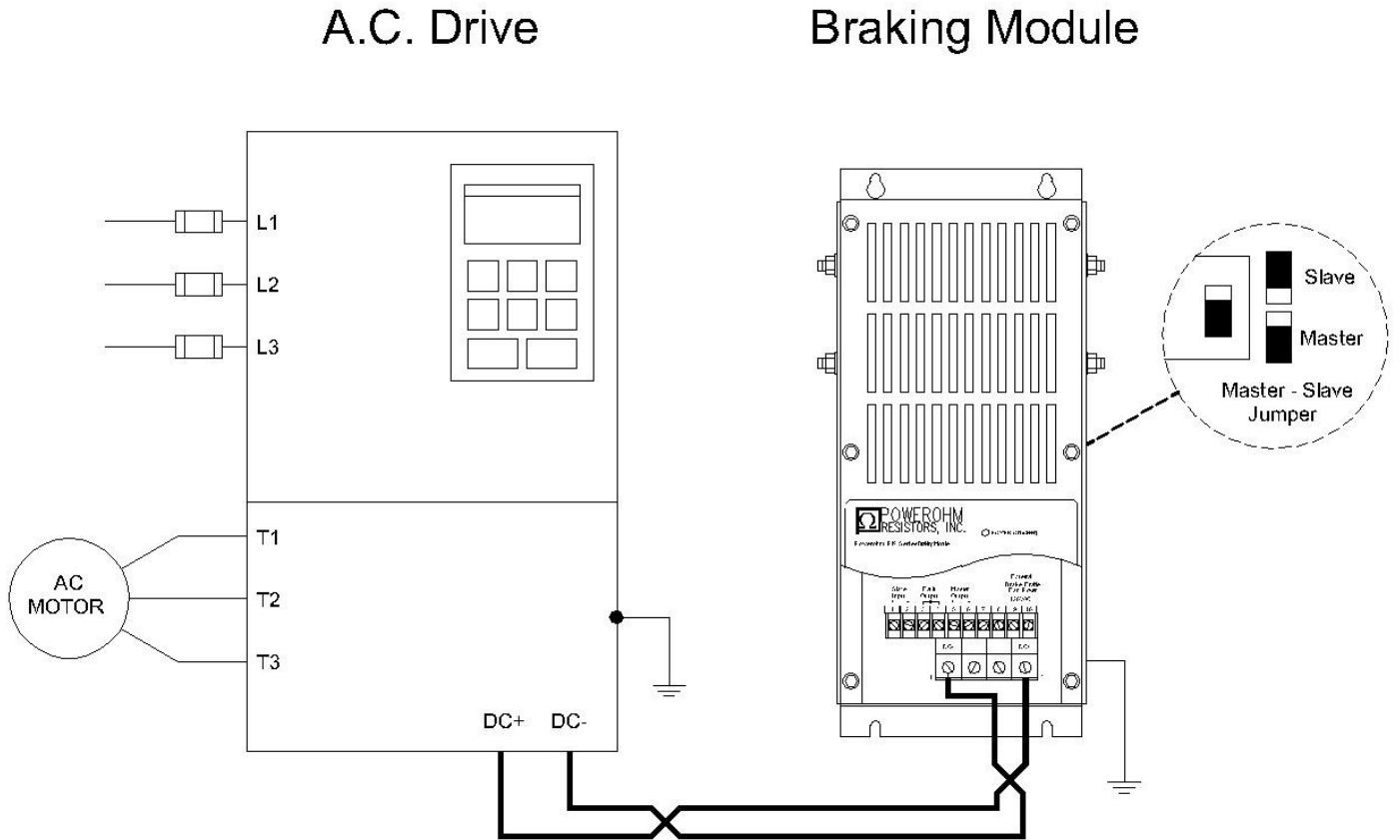

Master - Slave Jumper Settings: In the example above, the braking module is set as the Master (JP7 is the downward position).

Wiring Notes: All DC power wiring between the drive and braking module should be twisted (if possible) and run separate from all control wiring.

FIGURE 7: Power Connections for Multiple Braking Modules

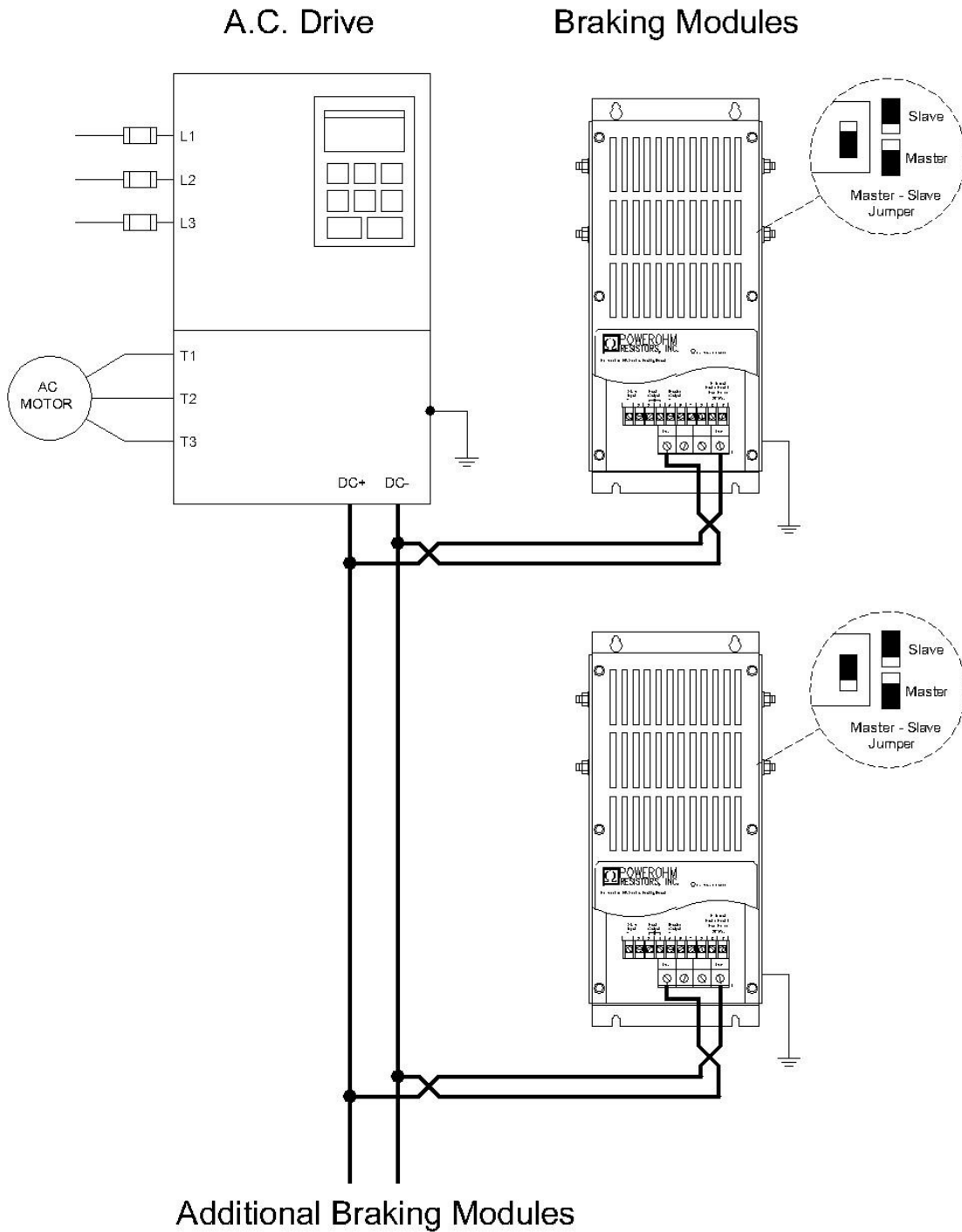

Master - Slave Jumper Settings: In the example above, the top braking module is set as the Master (JP7 is the downward position) and the lower module is in Slave Mode (JP7 is in the upward position).

Wiring Notes: All Power wiring should be twisted (if possible) and run separate from all control wiring.

FIGURE 8: Control Connections for Multiple Braking Modules

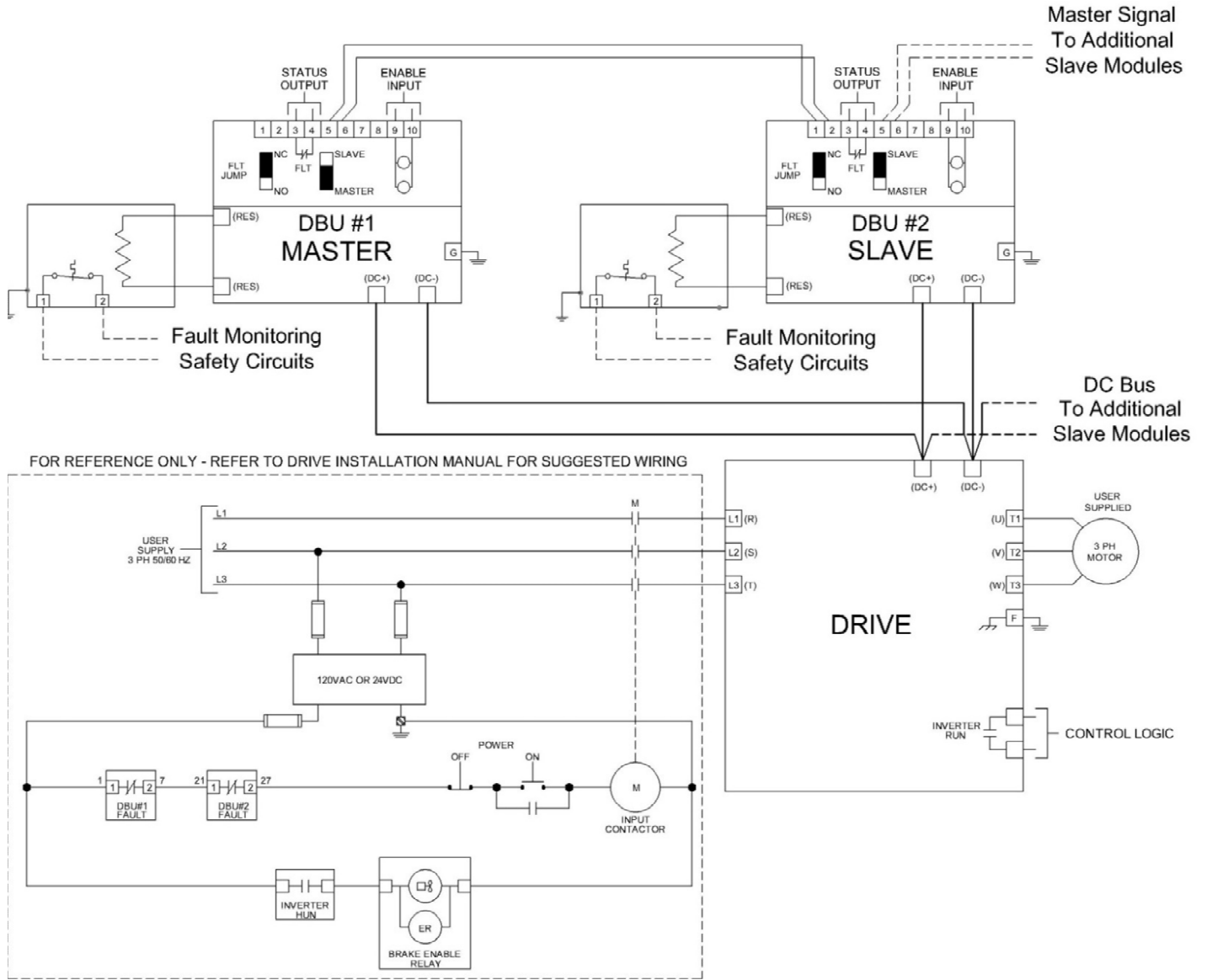

Master - Slave Jumper Settings: In the example above, the left braking module is set as the Master (JP7 is the downward position) and the right module is in Slave Mode (JP7 is in the upward position).

Wiring Notes: All Control wiring between the drive, braking module and braking resistor must be twisted and run separate from all Power wiring.

PRELIMINARY:

- Ensure the DC bus connections are proper polarity.
- Make sure that braking module voltage rating is equivalent to the drive and that all voltage selection jumpers are in the proper positions.
- Ensure the drives internal braking is disabled.
- Ensure the enable jumper is set according to your application. JP6 is Factory set for an external enable voltage at control board terminals 9 & 10 for the PKx-050.

THE BRAKE MODULE WILL NOT TURN ON IF THE MODULE IS NOT ENABLED.

- To see the internal LEDs it will be necessary to position yourself directly in front of the module front cover looking into the cover viewing hole.
- It is good practice to monitor the DC bus under stopped and braking conditions, making sure the braking setpoint is not too close to the nominal unloaded DC bus voltage.
- In order to best capture the peak voltage use an oscilloscope or voltmeter with a peak hold function.

POWER UP: As the DC bus pre-charges the green POWER ON LED illuminates indicating that DC bus voltage is properly applied to the DC- and DC+ power connections. At this time the braking and fault LEDs should be OFF. Note unloaded DC bus level.

BRAKING CYCLE: Start the drive and run the motor unloaded. Stop the drive quickly and monitor the green BRAKE LED. The LED will flash on, the heavier the braking, the more it flashes. Load motor, then start and stop drive and again monitor braking LED. Note DC bus level during the peak of the braking cycle. If the unloaded nominal DC bus is within 10% of the peak DC Bus during braking consider increasing the braking voltage threshold or using a drive contact to disable the brake while drive is idle.

DECELERATION: While under full load slowly decrease drive decel time while monitoring DC bus level. Decrease decel time as process allows until DC bus rises near the drive high bus trip level. Now increase decel time back to a level allowing a comfortable amount of headroom to prevent nuisance overvoltage trips. (If the drive trips on overvoltage easily or you can't stop the drive fast enough, the brake module may be undersized)

DUTY CYCLE: While under full load increase the duty cycle while monitoring the DC bus level and module resistors. If the resistors are glowing at the end of each braking cycle the duty cycle should be decreased, or a higher rated resistor should be used. (Although the resistors can take extreme temperature they will last longer if they are not stressed to the point of glowing)

FAULT: With the brake module sized correctly and the proper decel time and duty cycle settings the fault LED should never turn ON. If the fault LED turns on and the brake module is hot simply allow time to cool, and either increase the decel time, decrease the duty cycle, or use a higher rated brake module and resistor.

NORMAL LED INDICATORS

The PowerOhm Series PK Braking Module has three LED indicators that allow the user to verify the following:

POWER ON: An illuminated green LED indicates that DC bus voltage is applied to the DC- and DC+ power connections.

BRAKING: An illuminated or flashing green LED indicates that the module is braking.

FAULT: An illuminated red LED indicates that the module has over-heated **OR** the internal braking transistor has failed shorted. If the module overheated the fault LED will eventually turn off after a cooling period of about 2 minutes with fan running and about 20-30 minutes without fan running.

TURN ON LEVEL (ADJ.)

The TURN ON LEVEL adjusts at what DC bus voltage the braking module will turn ON and activate the braking resistor. This level is calibrated at the factory and should never be adjusted in the field by non-factory personnel. Generally speaking, it is best to operate the module with the highest allowable setting to allow for upward drift of the AC line during lightly loaded conditions.

Control board Jumpers JP1 – JP5 are a coarse adjustment and change the setpoint by approximately 4-5% for each position. If changing jumper positions the system power should be turned off and insulated needle nose pliers should be used.

ABNORMAL SYMPTOMS

- Before removing equipment covers or making any changes in jumper positions or adjustments, power down equipment and wait for DC bus to drop to safe levels. Always use an insulated screwdriver or insulated pliers when making jumper changes or adjustments
- Follow these steps and make note of indications before calling for help. Have unit model and serial number ready to aid PowerOhm in troubleshooting

GREEN POWER LED IS NOT ON

- Check for DC bus at input of brake chopper module
- If new installation check for loose wires or connections on control board
- If DC bus is present and all connections seem to be normal, replace module

BRAKING LED NEVER TURNS ON

- Check for proper voltage rating of control board
- Check for proper positioning of coarse voltage adjust jumpers
- Check enable jumper position and enable voltage at TB1-9 & 10 of control board
- Monitor DC bus and decrease decel time until DC bus rises enough to cause braking
- If all the above are OK, using insulated needle nose pliers move coarse voltage adjust jumper to the left one position and retry
- If moving jumper to the left three positions does not result in brake module turning ON, replace module

BRAKING LED TURNS ON BUT DRIVE TRIPS ON OVERVOLTAGE

- Ensure module is sized correctly
- Increase decel time or decrease duty cycle

BRAKING LED FLICKERS

- During light duty braking or at the end of a braking cycle it is normal for the LED to flicker some
- If the LED flickers when the Drive is idle there may be excessive noise on the DC bus from other equipment, a higher than expected AC line level, or high harmonics on the incoming voltage
- If the LED flickers when the drive is running normal load (not braking) there may be excessive common mode noise on the DC bus and addition DC bus filtering may be needed

BRAKING LED NEVER TURNS OFF / RESISTOR OVERHEATS

- Check for proper voltage rating of control board and jumper positions
- Ensure the brake module is connected DIRECTLY to the drive DC bus cap bank. Connecting up stream of the precharge circuits may result in high peak voltages that can turn on the brake module
- Check actual system AC line voltage for high harmonic content (high peak to RMS ratio) or for excessive noise spikes as this may cause an unusually high DC bus level on an unloaded drive
- If the above are OK, power down and using insulated needle nose pliers move coarse voltage adjust jumper to the right one position and retry
- If moving jumper to the right 3 positions does not result in brake module turning off, or the jumper cannot be moved further to the right, continue with next step
- Using an insulated screwdriver turn the adjustment pot CW. If the control board is working properly, and the DC bus voltage is normal, at some point the braking LED should turn off. This indicates the unit has been tampered with or some components have changed value and should be re-calibrated at the PowerOhm facility

BRAKING MODULE GETS HOT

- It is normal for PK brake modules to generate heat during operation
- Check regenerated power level and duty cycle to make sure module is sized correctly
- If the module *overheats* the fault LED will turn on and the output fault contact will change states

FAULT LED IS ON

- Check unit for heatsink or resistor overheating and allow time to cool
- Check for proper sizing of brake module as overheating indicates the module is running beyond its capacity
 - a. Reduce the duty cycle or increase the decel time
 - b. Use a higher rated braking module
- Confirm the 2 position thermostat plug at top of control board is seated properly
- If the above are OK, replace module
- ❖ If IGBT is shorted the fuse should be blown open and the fault will not reset

MASTER SLAVE SYSTEM DOES NOT WORK PROPERLY

- Check position of master slave jumpers on each module
- Make sure wiring between master and slaves is correct at TB1 of the control board
- Ensure the system is sized properly
- Monitor Braking LED on all modules. If master braking LED turns on but any slave does not, and wiring is correct, replace slave module(s). If master braking LED never turns on follow steps for “Braking LED never turns on”

“PK” Series Manual Rev. 2014-03-18

