

INSTALLATION INSTRUCTIONS

LED CANOPY LUMINAIRE

MODELS:

45W & 80W Canopy Luminaires

Model number parameter list:

Item	Model	Input Voltage	Power Factor	Watt	Input Current
A	45W LED Canopy	100-277V AC	≥0.9	45W	0.45A
B	80W LED Canopy	100-277V AC		83W	0.83A

1. Introduction

- An internal power-factor-corrected switch-mode power supply allows the luminaire to be used with a nominal 100V-277V, 50/60Hz AC supply without any variation in light output.
- Suitable for use wet locations in ambient temperatures from -40°C~+40°C (-40°F to +104°F)

Note: Save these instructions for future reference.

2. Install Guidelines

Warning:

To avoid the risk of fire, explosion, or electric shock, this product should be installed, inspected, and maintained by a qualified electrician only, in accordance with all applicable electrical codes.

Warning:

To avoid electric shock:

- Be certain electrical power is OFF before and during installation and maintenance.
- Luminaire must be connected to a wiring system with an equipment-grounding conductor.

Warning:

- Make sure the supply voltage is the same as the rated luminaire voltage.
- Do not operate in ambient temperatures above those indicated on the luminaire nameplate.
- Keep lens tightly closed when in operation.

For supply connections use wire rated for at least 100°C.

All unused holes must be sealed with waterproof silicone.

3. Installation:

There are three methods of installing the LED canopy luminaire:

- Pendant mounting
- Junction box mounting
- Ceiling mounting

Each method is explained below.

Pendant Mounting

- STEP 1.** Loosen (but do not remove screw A (see Figure 1), which holds the mounting plate in place.
- Slide the mounting plate toward Screw A, and then remove it from the luminaire body (see Figures 2 & 3).
 - Remove the rubber plug sealing the wireway enclosure by gently prying and pulling off the plug (see Figure 4).
 - Feed the incoming power wires from the luminaire into the pendant (use 3/4" conduit), install the pendant into the threaded hole in the luminaire casting, and securely tighten. Attach the other end of the pendant to a junction box.
 - If the incoming power wires from the luminaire are longer than the pendant, make wiring connections in the junction box. If the wires are not longer than the pendant, pull wires from the junction box as required, and make wiring connections inside the pendant (see Figure 5).

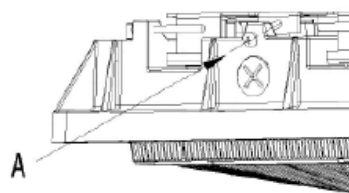

Figure 1

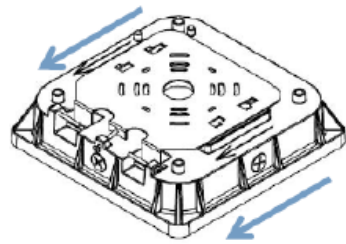

Figure 2

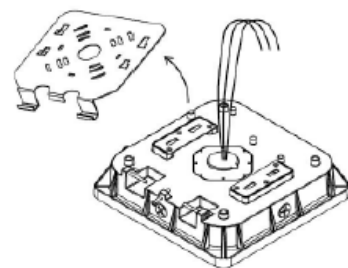

Figure 3

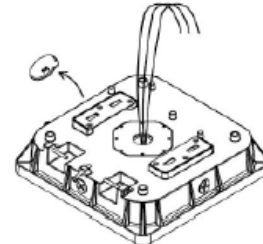

Figure 4

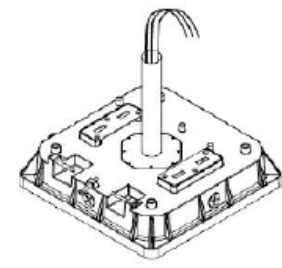

Figure 5

Junction Box Mounting

- STEP 1.** Remove the mounting plate (see Figures 1-3).
- Feed the incoming power wires from the junction box through the center hole in the mounting plate. Then, attach the mounting plate to the junction box using appropriate fasteners (see Figure 6).
 - Drill a hole in the center of the enclosed EVA (ethylene-vinyl acetate) foam gasket (see Figure 7). And then remove the sheet covering the adhesive. Feed the luminaire power wires through the drilled hole, and then apply the adhesive-side of foam gasket to the back of the luminaire housing to provide a watertight seal (see Figure 8).

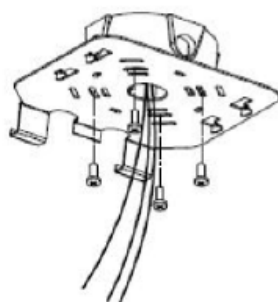

Figure 6

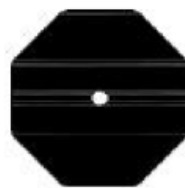

Figure 7

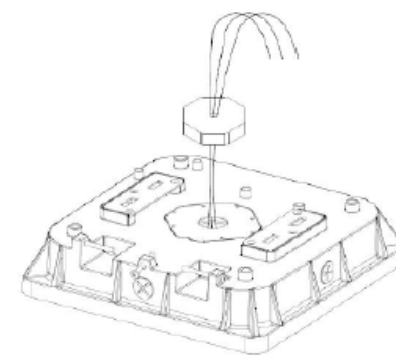

Figure 8

- Hang the luminaire onto the mounting plate hooks, and then connect the black, white and yellow / green luminaire wires to incoming power wires (black to line, white to neutral, and yellow / green to ground). See Figure 9 and wiring Diagrams.

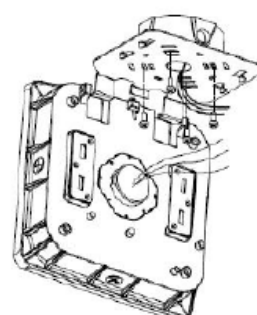

Figure 9

5. Rotate the luminaire body up towards the mounting plate, and slide the mounting plate hooks into the slots on the luminaire body. Then, slide the luminaire body away from screw A to securely engage the mounting plate hooks in the slots. See Figure 10.

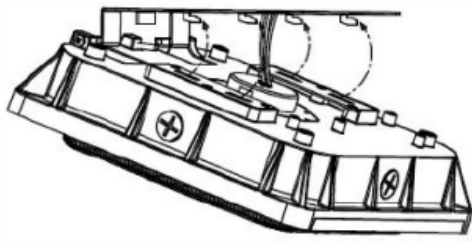

Figure 10
Rotate luminaire housing up,
then slide the housing back.

6. Retighten screw A to hold the mounting plate in place on the luminaire body. See Figure 11.

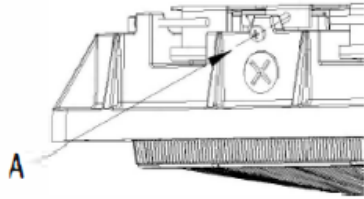

Figure 11

Ceiling mounting

STEP 1. Remove the polycarbonate lens and sheet metal reflector (see Figure 12).

Note: Be careful to avoid touching the LEDs, or irreversible damage may occur.

2. Drill holes in each of the four mounting channels in the die cast housing (see Figure 13).
3. Drill four corresponding holes in the mounting surface. Use the drilling patterns shown in Figures 14 and 15, below.
4. Attach the luminaire housing to the mounting surface using appropriate fasteners (see Figure 16).
5. Use waterproof silicone to seal all holes.

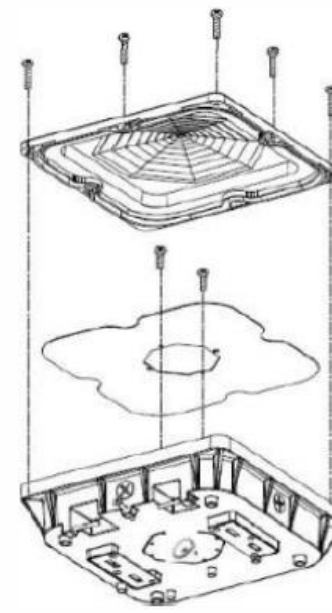

Figure 12

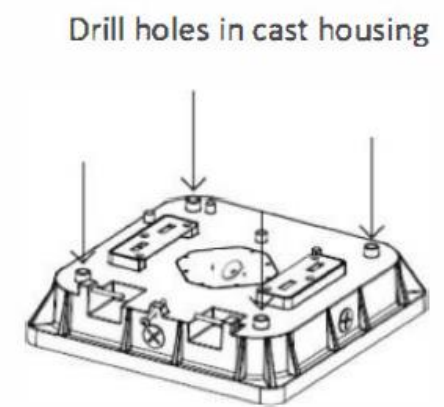

Figure 13

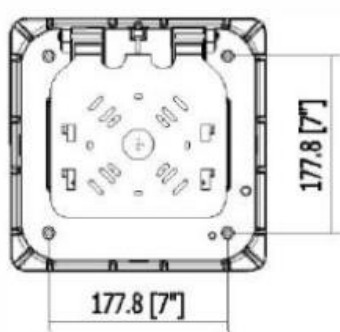

Figure 14

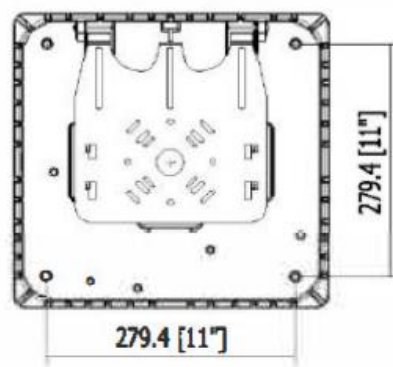

Figure 15

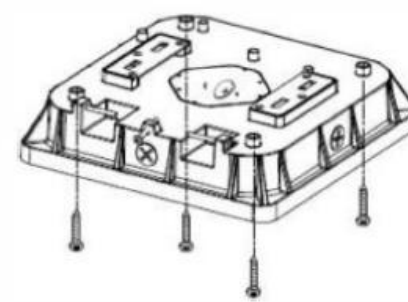

Figure 16

6. Pull the incoming power wires attached to the surge protector from the back of the luminaire housing.
7. Remove one of the 1/2" conduit plugs from the side of luminaire housing (see Figure 17).

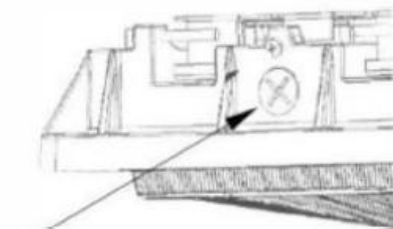

Figure 17

8. Insert threaded conduit or a conduit connector into the 1/2" hole, and securely tighten. Use waterproof silicon to prevent moisture intrusion.
9. Feed incoming power wires through the conduit and into the luminaire housing, and connect the black, white and yellow / green luminaire wires to incoming power wires (black to line, white to neutral, and yellow / green to ground). See Wiring Diagrams, below.
10. Reattach the sheet metal reflector and polycarbonate lens to the luminaire housing (see Figure 12).

Wiring Diagrams

Without Photocell

