

**General information on handling
and maintenance of SDC™ Solid Dielectric
Capacitor Bushings**



Electro Composites[™]

solid HV bushings solution

Foreword

This guide is intended to address issues strictly relating to ELECTRO COMPOSITES (2008) ULC cycloaliphatic epoxy resin, dry type bushings for use on transformers, circuit breakers and reclosers. Issues relating to any other ELECTRO COMPOSITES (2008) ULC product should be addressed with ELECTRO COMPOSITES (2008) ULC Technical staff.

These guidelines are presented as suggestions only and are not intended to reflect the specific conditions of our product's usage on your equipment. As such, we recommend that you use this information carefully and take the necessary steps to ensure that it accommodates your particular application and operating conditions. The reader is requested to address any questions or concerns directly with ELECTRO COMPOSITES (2008) ULC technical staff for further information and instructions on proper installation, use and maintenance of our bushings.

ELECTRO COMPOSITES (2008) ULC makes no warranty, representations, whether express or implied, or representation and assumes no liability for the accuracy of the information in this document or the use of such information. All information contained in this guide is subject to change without prior notice. PLEASE REFER TO THE DISCLAIMER OF WARRANTIES AND LIMITATION OF LIABILITY at the end of this document.

Electro Composites™

solid HV bushings solution

This guide is intended to provide the user with information concerning the handling and maintenance of ELECTRO COMPOSITES (2008) ULC polymeric bushings, from the time the bushings are received until they are put into service, as well as general maintenance guidelines after specific in-service periods. All possible contingencies, which may arise during installation, operation, or maintenance, and all details and variations of this equipment, are not purported to be covered in this guide. For any questions that may arise and not covered by this guide, the reader is recommended to contact ELECTRO COMPOSITES (2008) ULC for assistance.

GENERAL BUSHING INFORMATION

ELECTRO COMPOSITES (2008) ULC Dry Type bushings are designed for use on transformers and oil circuit breaker applications, up to 170 kV voltage class and 5000A current rating. Bushings can be designed to conform to the following bushing standards:

- IEC 60137: Insulated Bushings for Alternating Voltages Above 1000V
- ANSI/IEEE C57.19.01: Standard Performance Characteristics and Dimensions for Outdoor Apparatus Bushings
- ANSI/IEEE C57.19.00: Standard General Requirements and Test Procedure for Outdoor Power Apparatus Bushings
- CAN/CSA C88.1: Power Transformer and Reactor Bushings

(Please refer to the bushing drawing for the applicable standard)

ELECTRO COMPOSITES (2008) ULC bushings consist of a central electrolytic copper conductor, either solid core or draw-lead type, encapsulated in a monolithic solid rigid cycloaliphatic epoxy resin dielectric body. External sheds are integral to the epoxy core eliminating all interfaces through the insulating core. A high strength aluminum flange is bonded to the epoxy body and allows for mounting. All working surfaces are precision machined for optimal fit. The flange is designed to insure maximum seal – with no leakage permitted between the flange and the epoxy body. A non-foil condenser shield (or series) is cast into the resin along with the conductor, providing necessary E-Field grading and distribution. In the case of oil circuit breaker type bushings, the condenser shield is permanently connected to the metallic flange via a setscrew insuring shield grounding. In the case of transformer type bushings, a capacitance tap connection is supplied. The outermost shield is accessible through a threaded pin, insulated from the flange when the capacitance tap button is removed, allowing for capacitance and power factor measurements.

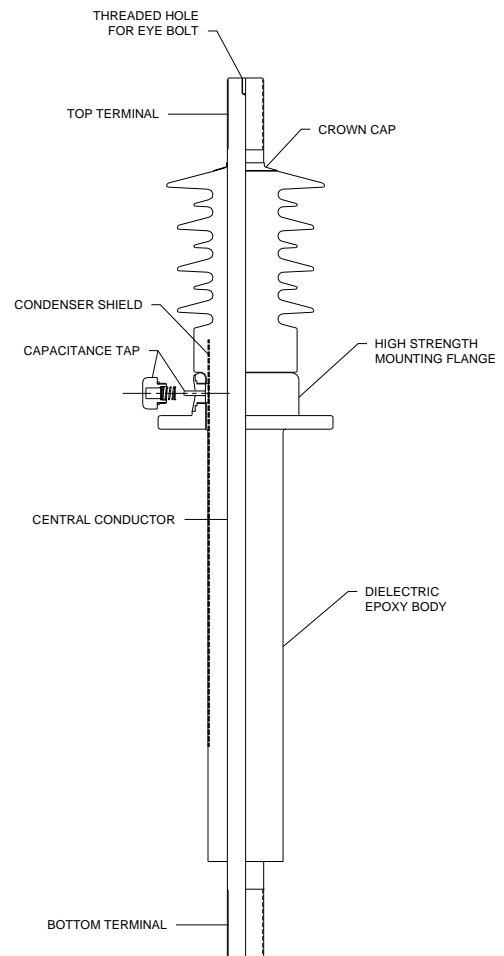

Electro CompositesTM

solid HV bushings solution

There is no oil or other fluids or gases used in the construction of ELECTRO COMPOSITES (2008) ULC bushings.

AT ALL TIMES VERIFY THAT THE BUSHING IS PROPERLY GROUNDED AND THAT THE CAPACITANCE TAP SPRING AND CONTACT WASHER ARE IN PLACE WHEN THE TAP COVER IS CLOSED, OTHERWISE THE GROUNDING SHIELD WILL NOT BE GROUNDED AND BUSHING FAILURE WILL OCCUR.

After installation of the bushing on the equipment, before the bushing is energized, proper steps must be taken to insure the bushing is grounded. Verification of the ground contact can be done by measuring the resistance between the bushing flange and the equipment on which the bushing is installed using an ohm-meter. A maximum value of 0.5 ohm should be measured under dry condition. If the measured value is greater than the limit indicated, check the bushing installation and verify the resistance again, or provide other means to ground the bushing to the equipment. ELECTRO COMPOSITES (2008) ULC bushings are not supplied with a potential or voltage tap. Never exceed 1000V when testing the bushings for capacitance and power factor measurements. However, test taps are insulated to 2000V.

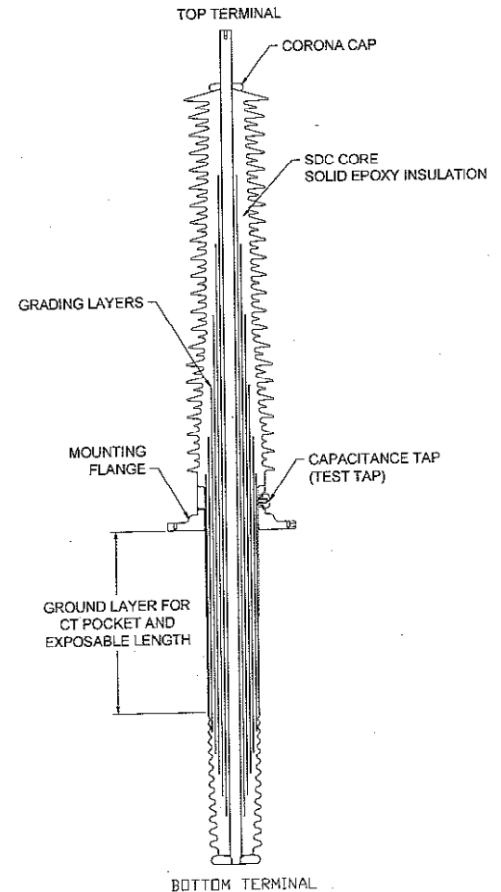

This document does not purport to provide safe practices for use of equipment or the performance of work around equipment where ELECTRO COMPOSITES (2008) ULC bushings are installed. Installation and maintenance of ELECTRO COMPOSITES (2008) ULC bushings is to be carried out by trained, certified and approved personnel only. Although ELECTRO COMPOSITES (2008) ULC bushings present no danger to personnel when not energized, reasonable care is to be taken when handling and transporting bushings. Some edges may be sharp and bushings are bulky and heavy.

Electro CompositesTM

solid HV bushings solution

SHIPPING

ELECTRO COMPOSITES (2008) ULC bushings are shipped in OSB board (presswood) crates, supported at two points. Bushings are shipped horizontally or exceptionally at vertical position.

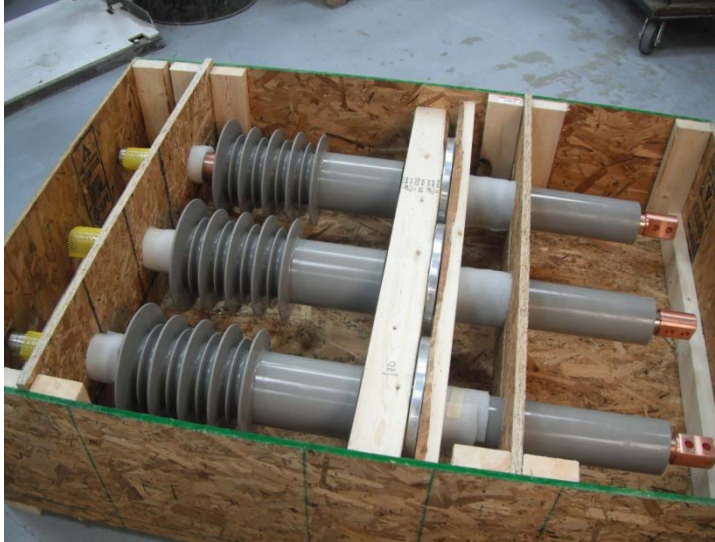

As ELECTRO COMPOSITES (2008) ULC bushings are dry type (no oil or any other fluid components within the bushing construction), no special provisions are given for their shipping and storage other than given in this guide. Therefore, they can be stored in their shipping crates for an indefinite period of time.

When returning bushings to ELECTRO COMPOSITES (2008) ULC, please use the same crating and strapping methods as when they were shipped originally. Insure you have been provided a RMA (Return Material Authorization) number from your Electro Composites (2008) ULC representative prior to returning any material back to the factory.

RECEIVING

Bushing crates are constructed with provisions for handling with forklift equipment. Insure for sufficient support of crate, as weight distribution within the crate is not balanced. Reasonable care should be taken when opening the crate so as not to accidentally damage the bushing. Crates are usually assembled with wood screws.

Inspect crate and bushing(s) carefully for any signs of damage that may have occurred during transport. Visually inspect each bushing for any signs of impact, cracks, loose components or abnormal surface conditions.

When opening the crate, take particular care to remove all screws, nails, staples and any other sharp metal parts which could damage the bushing or personnel. When using any kind of cutting blades, stay clear of the bushing insulation surfaces to prevent damage to the insulation.

Electro Composites™

solid HV bushings solution

Bushing routine test reports should be included with the shipping documents on the crate. Please insure that the test documents match the bushings as indicated on the bushing nameplates located on the flange. **IN THE EVENT OF A MISMATCH, QUARANTINE THE BUSHINGS AND CONTACT YOUR ELECTRO COMPOSITES (2008) ULC REPRESENTATIVE IMMEDIATELY. DO NOT INSTALL THE BUSHINGS UNDER ANY CIRCUMSTANCES.**

STORAGE

We recommend storing ELECTRO COMPOSITES (2008) ULC bushings indoors, in dry and normal room temperature conditions. However, if necessary, ELECTRO COMPOSITES (2008) ULC bushings can be stored outdoors (temperature range from -50°C to 60°C) if properly covered to maintain dryness. Please contact ELECTRO COMPOSITES (2008) ULC technical staff for outdoor storage recommendations.

HANDLING

The bushing can be removed from the crate by several means. The preferred and recommended method consists of using an eyebolt threaded into the central copper conductor at the top end termination. Insure the eyebolt is fully threaded into the hole and tightened accordingly. Alternatively, an anchor shackle with the shackle pin attached through a flange mounting hole can be used. As a last resort, a non-metallic choker rope or sling can be strapped under the top shed to lift the bushing. Handle the bushing with care and take all necessary precautions to prevent it from falling or bumping into surrounding objects. Do not subject the bushing to sudden shocks. Slowly take up the slack in the attachment, and then raise the bushing at a constant and steady rate.

WARNING: UNDER NO CIRCUMSTANCES IS THE BUSHING TO BE LIFTED BY A CHAIN STRUNG ON, AROUND OR TOUCHING THE EPOXY SHEDS. DAMAGE TO THE INSULATION MAY OCCUR. ELECTRO COMPOSITES' WARRANTY DOES NOT COVER SUCH IMPROPER HANDLING PRACTICES.

METHOD 1 WITH WELDED U-BOLT OR THREADED EYEBOLT:

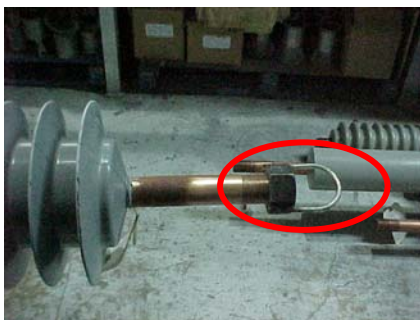

OR



Electro CompositesTM

solid HV bushings solution

METHOD 2 WITH ANCHOR SHACKLE IN FLANGE HOLES:

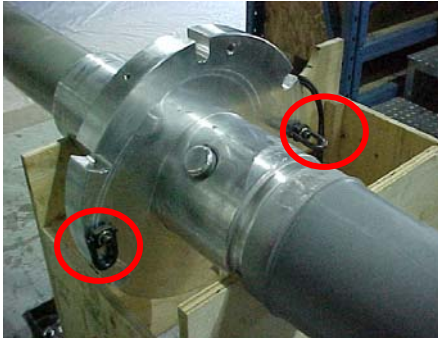

METHOD 3 WITH A CHOKER ROPE OR SLING WELL BALANCED:

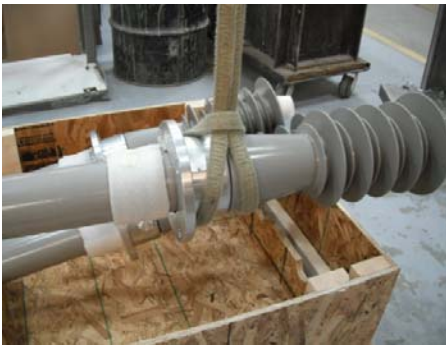

Handle the bushing with care and take all necessary precautions to prevent it from falling or bumping into surrounding objects while it is being manipulated. Bushings may be top heavy or bottom heavy – always keep a firm grip on the top end terminal of the bushing to keep it from pivoting from horizontal. Do not subject the bushing to sudden shocks. Slowly take up the slack in the attachment and then raise the bushing at a constant and steady rate. Insure that the lifting chain or straps do not rub up against the insulation which may damage it.



It is compulsory to keep this end in balance

Electro Composites[™]

solid HV bushings solution

INSTALLATION/TESTING

Before installation, remove all wrapping material and foreign particles from the bushing. Clean the conductor end terminal threads, aluminum flange seat and wipe clean the epoxy (grey color) insulation with a dry clean cloth (both ends). The insulation can also be thoroughly cleaned with a clean cloth and isopropyl alcohol or acetone to remove any trace oil or grease that may be present.

We recommend performing the capacitance and power factor tests prior to energizing the bushing. Remove the bushing from its crate and clean beforehand. Refer to the Doble M400 Test set instructions, the Doble Bushing Field Test and our Routine Test Report for the measured values (these should match the values indicated on the bushing name plate). Bushings can be tested immediately after removal from the crate. Discrepancies between the measured values and the indicated values on the name plate can occur since nameplate values are obtained under controlled conditions at the factory. Values measured at receiving should be used as a baseline to compare with future field measurements. Only C1 power factor and capacitance have meanings for SDC[™] bushings

NOTE: Electro Composites (2008) ULC recommends against measuring C2 power factor and capacitance of our bushings for any purpose. Should C2 power factor and capacitance measurements be part of your tracking procedure, measurements should be made once the bushing is installed on the equipment. Measured values can then be used as benchmarks for monitoring purposes. Values will generally vary from nameplate.

ATTENTION!

- **Never test the bushing while in the shipping crate**
- **When possible, place the bushing in a grounded test stand. It is important to isolate the flange from the grounded stand using a good insulation material. Wood can contain significant moisture and should not be used.**
- **The readings may be taken with the bushing installed in the equipment provided that top terminal connections are not made.**

Electro Composites™

solid HV bushings solution

ELECTRO COMPOSITES (2008) ULC bushings can be installed at any angle. A proper gasket is required between the flange and the equipment. In case of mounting problems, contact ELECTRO COMPOSITES (2008) ULC for further corrective action. Do not for any reason modify or alter any part of the bushing, including the aluminum flange.

When bolting the bushing to the equipment, tighten each bolt no more than a half turns at a time. Follow a criss-crossing bolt tightening sequence as shown in the figure below.

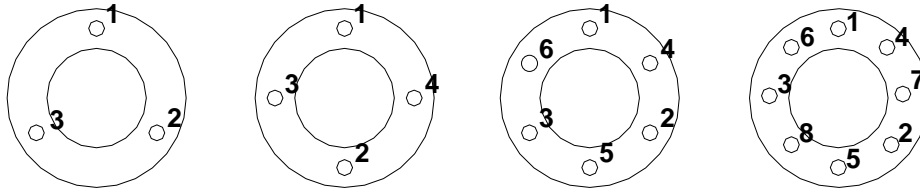

Please refer to the bushing drawing for proper flange bolt tightening torque. By using the proper tightening torque for the bolt size used and the tightening sequence provided, flange damage and sealing problems from improper tightening and uneven pressure on the gasket can be avoided. The use of a calibrated torque wrench is recommended.

Before tightening, insure that the conductor terminal ends are free to move since as the flange is tightened, a small displacement at the flange will cause a much larger displacement at the terminal ends. Potential damage to the bushing and equipment is possible if this is not done.

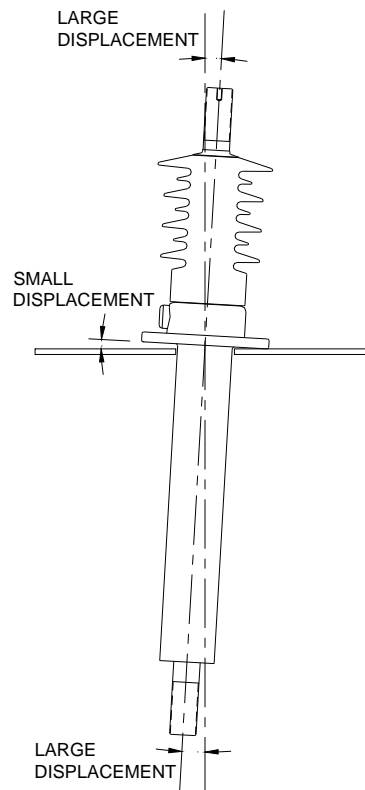

Electro Composites™ solid HV bushings solution

CAPACITANCE TEST TAP

The capacitance test tap is used for capacitance and power factor measurements. INSURE BUSHING IS NOT ENERGIZED PRIOR TO MEASUREMENT. The test tap is located on the bushing mounting flange. Generally, capacitance test taps are supplied only with transformer bushings. However, some users request them to be supplied with oil circuit breaker bushings as well. For measurement taking, unscrew the capacitance tap button, carefully removing it with the terminal spring and contact washer, exposing the contact pin. Do not separate the terminal spring and contact washer from tap cap. Once measurements are done, replace the button and tighten by hand or with a wrench until the O-ring is compressed and seats tightly against the flange body.

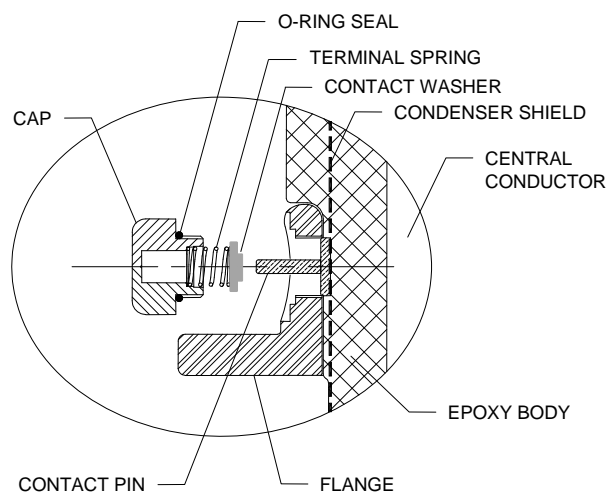

NAMEPLATE

Every bushing is supplied with a nameplate located on the mounting flange. Nameplate will provide all pertinent information relevant to the bushing: manufacturer name and address, model number, serial number, voltage class, current rating, BIL, C1 and PF. When requesting information concerning a specific bushing, please be sure to provide at a minimum the model number and serial number. The serial number is comprised of two sets of 4 numbers followed by a 7 digits date code (4625-3855-1012001 as below).

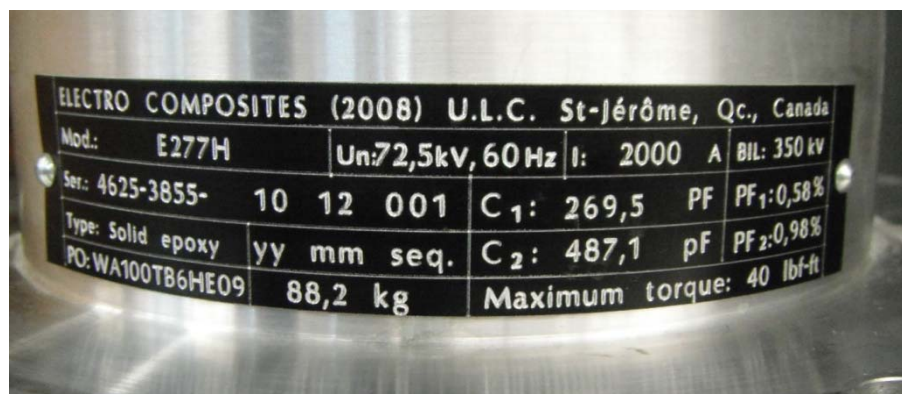

Electro Composites[™]

solid HV bushings solution

MAINTENANCE

ELECTRO COMPOSITES (2008) ULC bushings are designed for outdoor, severe condition service with minimal maintenance requirements. The only serviceable components on SDC[™] bushing are the test tap and removable threaded terminals on draw-lead type designs. However, bushings exposed to salt spray, cement dust or other abnormal deposits must be cleaned regularly to prevent flashover and corrosion of metal parts. Cleaning should be done before performing routine power factor and capacitance measurements (bushings with a capacitance tap only).

AFTER 1 MONTH OF SERVICE AND YEARLY

Check the bushing insulation (epoxy part) for signs of cracks or chips and surface contamination deposits. Should treeing be visible, clean the affected area with isopropyl alcohol. Insure all connectors are tight and there are no loose components. Inspect the bushing with an IR camera to determine if there is a hot spot, which would be indicative of a bad or loose connection.

ONCE EVERY 3 TO 5 YEARS

Perform the yearly maintenance check and cleaning. Perform a Doble test for Power Factor and Capacitance. Refer to the Doble M-4000 test set instructions, Doble Bushing Field Test Guide, and ELECTRO COMPOSITES (2008) ULC instructions for proper test procedures. Refer to values measured at bushing receiving for baseline value. See INSTALLATION/TESTING section in this document.

FIELD REPAIRS

Any damage to a bushing, which might make repair either desirable or necessary, should be reported to ELECTRO COMPOSITES (2008) ULC. Typically, a small chip at the end of a shed will have very little effect on the bushing's function. Do not try to fill chips with epoxy, as this will have no beneficial effects. For small chips, simply sands down the sharp edges with a fine grit sandpaper. Since the bushing insulation is essentially a solid epoxy casting, chips in the insulation surface will not cause any moisture problems. Should a crack be found, DO NOT ATTEMPT TO REPAIR THE BUSHING AND NOTIFY ELECTRO COMPOSITES (2008) ULC IMMEDIATELY.

Electro CompositesTM

solid HV bushings solution

DISCLAIMER OF WARRANTIES AND LIMITATION OF LIABILITY

THERE ARE NO UNDERSTANDINGS, AGREEMENTS, REPRESENTATION OR WARRANTIES, EXPRESS OR IMPLIED, INCLUDING WARRANTIES OF MERCHANTABILITY OR FITNESS FOR A PARTICULAR PURPOSE OTHER THAN THOSE SPECIFICALLY SET OUT IN AN EXISTING CONTRACT BETWEEN THE PARTIES. ANY SUCH CONTRACT STATES THE ENTIRE OBLIGATIONS OF SELLER. THE CONTENTS OF THIS DOCUMENT SHALL NOT BECOME PART OF OR MODIFY ANY PRIOR OR EXISTING AGREEMENTS OR COMMITMENT OF RELATIONSHIP.

THE INFORMATION, RECOMMENDATIONS, DESCRIPTIONS AND SAFETY NOTATIONS IN THIS DOCUMENT SHOULD NOT BE CONSIDERED TO BE ALL INCLUSIVE OR COVERING ALL CONTINGENCIES. IF FURTHER INFORMATION IS REQUIRED, ELECTRO COMPOSITES (2008) ULC SHOULD BE CONSULTED.

NO WARRANTIES, WHETHER EXPRESS OR IMPLIED, INCLUDING WARRANTIES OF FITNESS FOR A PARTICULAR PURPOSE OR MERCHANTABILITY, OR WARRANTIES ARISING FROM THE COURSE OF DEALINGS OR TRADE USAGES, ARE MADE REGARDING THE INFORMATION, RECOMMENDATIONS, DESCRIPTIONS, AND SAFETY NOTATIONS CONTAINED HEREIN. IN NO EVENT WILL ELECTRO COMPOSITES (2008) ULC BE RESPONSIBLE TO THE USER IN CONTRACT, IN TORT OR DELICT (INCLUDING NEGLIGENCE), STRICT LIABILITY OR OTHERWISE, OR FOR ANY DIRECT OR INDIRECT, INCIDENTAL, OR CONSEQUENTIAL DAMAGES OR LOSS WHATSOEVER INCLUDING BUT NOT LIMITED TO DAMAGES TO OR LOSS OF USE OF EQUIPMENT, PLANT OR POWER SYSTEM, COST OF CAPITAL, LOSS OF PROFITS OR REVENUES, COST OF REPLACEMENT POWER, ADDITIONAL EXPENSES IN THE USE OF EXISTING POWER FACILITIES, OR FOR CLAIMS AGAINST THE USER BY ITS CUSTOMERS RESULTING FROM THE USE OF THE INFORMATION, RECOMMENDATIONS, DESCRIPTIONS, AND SAFETY NOTATIONS CONTAINED HEREIN.