

Self-Testing/Self-Diagnostic Emergency Models

SPECTRON®

All models ordered with the Dual-Lite Spectron self-testing/self-diagnostic electronics system provide:

- Visual indication of AC power status
- Visual indication of all self-diagnostic test cycles
- Visual indication of unit malfunctions including:
 - Battery fault
 - Charger fault
 - Transfer Fault
 - Lamp fault

Bi-Color LED Status Indicator

Self-testing/self-diagnostic units are provided with a single, bi-color LED which serves as a combination AC power, self-test and service alert status indicator. During normal operation, the green status LED will be constantly illuminated, indicating the presence of AC power. During all automatic or manual self-test cycles, the green Status LED will blink at a one cycle per second rate indicating "Test In Progress". If a fault condition is detected during any automatic or manual self-test cycle, upon completion of test, the red status indicator will provide a "service alert code" – see table below.

Service Alert Code	Description
One blink ON/pause	Battery not connected
Two blinks ON/pause	Battery fault
Three blinks ON/pause	Charger fault
Four blinks ON/pause	Transfer circuit fault
Five blinks ON/pause	Lamp failure

EMERGENCY MODEL TROUBLESHOOTING

AC-On Light does not illuminate

- Check AC wiring connections

Emergency LEDs do not work

- Battery is shipped disconnected. Connect leads from battery to charger PCB and charge before testing.
- Make sure connections to LED board are properly seated.
- Check wiring connections.

Maintenance

Exit signs should be tested and maintained in accordance with National Electrical Code and NFPA 101 Life Safety Code requirements. It is recommended that exit signs be tested for a minimum of 30 seconds once a month and 90 minutes once a year.

The automatic monthly tests of the Spectron units satisfy this requirement. The required annual test can be initiated manually with the test switch, as required by the safety code.

Hubbell Lighting, Inc. Life Safety Products • www.dual-lite.com

Copyright© Hubbell Lighting, Inc., All Rights Reserved • Specifications subject to change without notice. • Printed in U.S.A. [EC 090204002]

Manual Test

Using the unit test switch, users can initiate different duration test cycles based on the following table:

To Initiate Action:	Test Cycle
Press switch once	1 minute
Press switch twice	90 minute

Pressing test switch at any time after a test cycle has begun cancels the remainder of test and returns the unit to normal operation. (NOTE: Batteries are often shipped in a discharged state – this is normal – battery requires charging. Allow several hours of charge before testing unit.)

Spectron units also provide:
 Brownout protection – unit transfer to emergency mode with low AC input voltage.
 Time Delay Re-transfer – unit will remain in emergency mode for additional time after AC power is restored.

RECYCLING INFORMATION

All aluminum components are recyclable. All cartons contain recycled materials. Please recycle.



NOTICE:

Emergency exit signs contain rechargeable batteries which must be recycled or disposed of properly. Use CAUTION when handling batteries.

LED REPLACEMENT

(Contact factory)



SEWL Series

Wet Location/NEMA 4X Die-Cast Aluminum LED Exit Sign
 Installation, Operation and Maintenance Instructions



IMPORTANT SAFEGUARDS

When using electrical equipment, basic safety precautions should always be followed including the following.

READ AND FOLLOW ALL SAFETY INSTRUCTIONS

1. Do not let power supply cords touch hot surfaces.
2. Do not mount near gas or electric heaters.
3. Equipment should be mounted in locations and at heights where it will not readily be subject to tampering by unauthorized personnel.
4. The use of accessory equipment not authorized by the manufacturer may cause an unsafe condition.
5. Do not use this equipment for other than its intended purpose.
6. Service of this equipment should be performed by qualified service personnel.

INSTALLER:

- SEE UNIT LABEL FOR ADDITIONAL MODEL SPECIFICATIONS
- SAVE THESE INSTRUCTIONS FOR USE BY OWNER/OCCUPANT



WARNING – This product can expose you to chemicals including lead and lead compounds, which are known to the State of California to cause cancer and birth defects or other reproductive harm. For more information go to www.P65Warnings.ca.gov.

93094171
 93094183
 93094622

93092987 B 03/19



HUBBELL
 Lighting

Wall Mount N4X Installation

IMPORTANT: TO WEATHERPROOF FOR OUTDOOR INSTALLATION, BE SURE TO SEAL ALL OPENINGS-MOUNTING, CONDUIT, ETC.

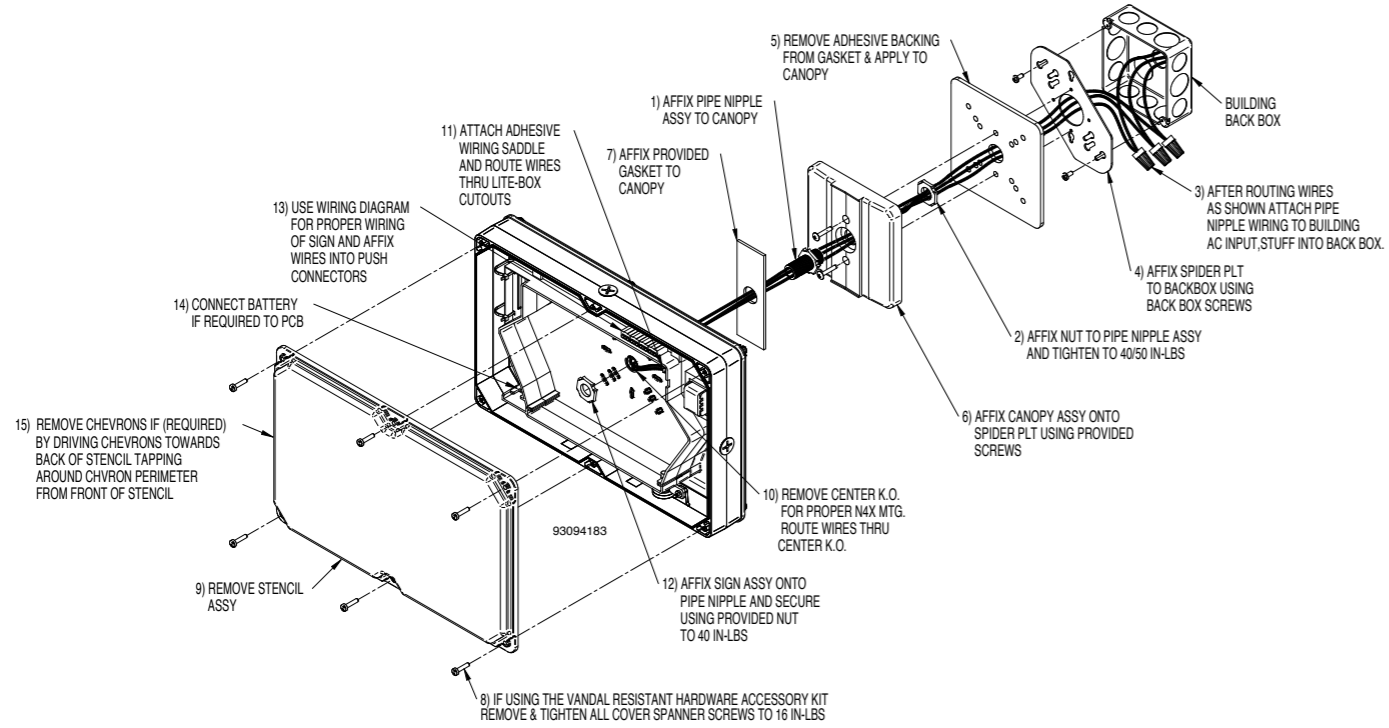

WIRING DIAGRAM

AC TRANSFORMER
120VAC CONNECT BLACK & WHITE LEADS
277VAC CONNECT RED & WHITE LEADS

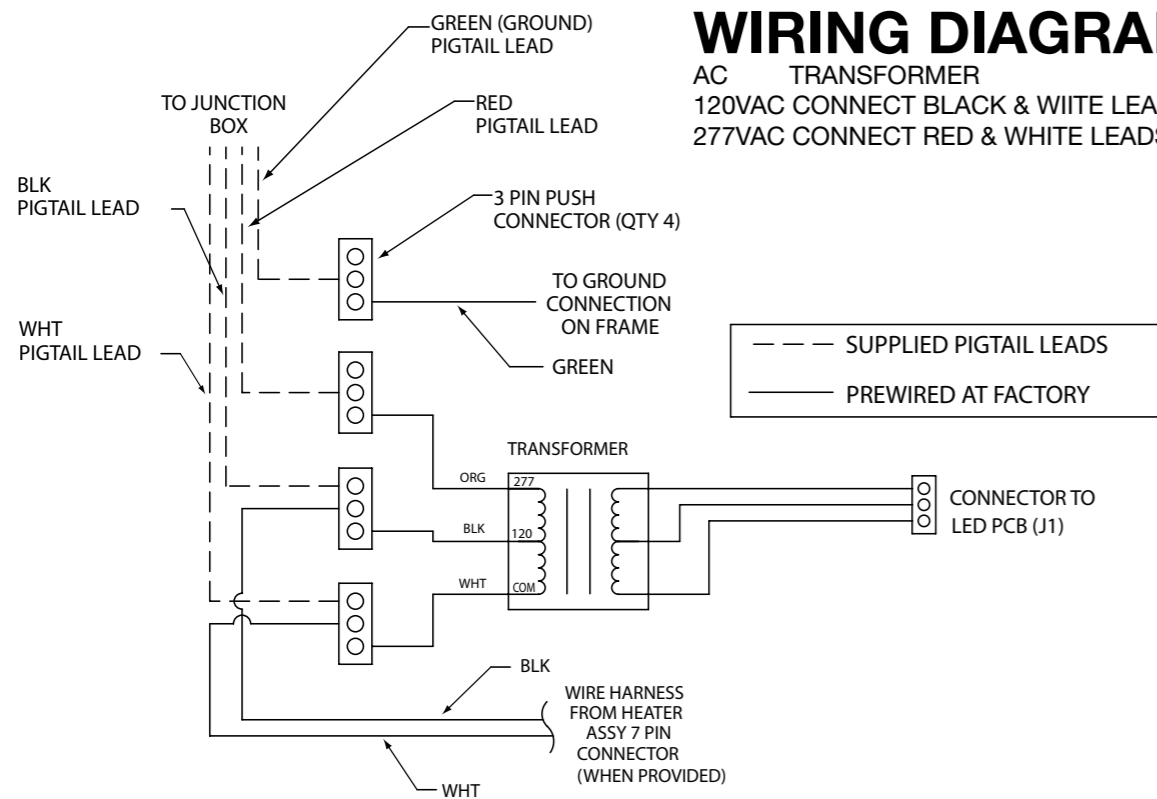

CEILING OR END MOUNT N4X INSTALLATION

IMPORTANT: TO WEATHERPROOF FOR OUTDOOR INSTALLATION, BE SURE TO SEAL ALL OPENINGS-MOUNTING, CONDUIT, ETC. FOR END MOUNTING OF SIGN USE SAME PROCEDURES AS CEILING

