

CHANCE® Helical Underpinning Bracket C1500934

Installation Instructions

The product must be installed by Chance certified dealers trained to install the CHANCE® Helical Pile System.

1. Bracket C1500934 is used with 1-1/2" (38 mm) SS5 & SS150 Square Shaft and 2-7/8" (73 mm) RS2875.203 & RS2875.276 Round Shaft Helical Piles. Always use the correct bracket and T-Pipe for the Helical Pile installed. Brackets are stamped on vertical gusset "LC".

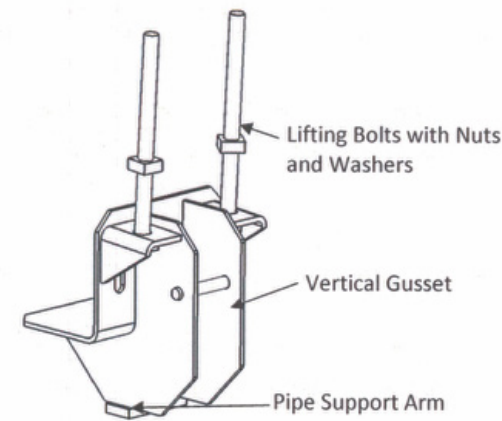

Bracket Body, Lifting Bolts and Cross Stud

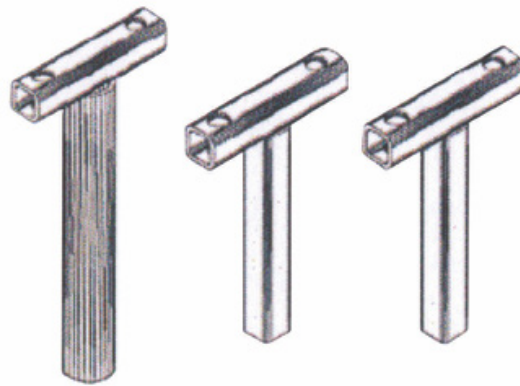

T-Pipes for Bracket C1500934

FROM LEFT TO RIGHT:
C150-0486 STANDARD STRENGTH, SS5 & SS150
C278-8012 STANDARD STRENGTH, RS2875.276
C278-0001 STANDARD STRENGTH, RS2875.203

2. Excavate a hole at each location where an underpinning bracket is to be installed. The hole should not be over-excavated so that soil disturbance is minimized. Generally, a hole 12" (300 mm) below the footing is required to install the bracket. The width of the hole should be at least 12".

⚠ WARNING

Potential for Soil Collapse. Can cause injury or death. When digging large holes, take appropriate shoring measures. Always abide by all local and OSHA requirements.

Hubbell has a policy of continuous product improvement. Please visit hubbellpowersystems.com to confirm current design specifications.

3. Clean off soil attached to the bottom of footing. Prepare the footing by chipping away irregularities from the bottom and sides. Typically, the footing is chipped to be flush with the wall, minimizing eccentricity. The Bracket must fit snugly and be flush to the foundation.

⚠ WARNING

Incorrect footing preparation will prevent proper seating of the bracket against the footing. Can result in bracket rotation or damage to the bracket, pile, jacking equipment, footing or entire structure. Provide flat, smooth surface for the bracket to mount against.

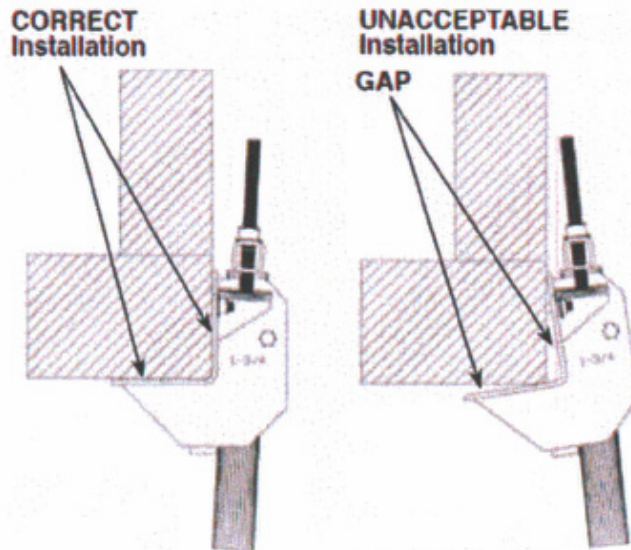

4. Place the Helical Pile in the excavated hole. The pile should be centered along the width of the hole. Secure the top of the Helical Pile to the installing tool/hydraulic torque motor. Always use the Bent Arm Pin and Coil Lock provided for secure attachment of the Helical Pile to the installing equipment.
5. For single helix piles, the helix should be placed under the foundation with the pile shaft at a 3-5 degree angle from vertical and the shaft should be as close to the foundation as possible.

⚠ WARNING

Misuse of helical pile installing equipment can result in property damage, severe injury or death. Read and understand the instructions and warnings before beginning helical pile installation.

⚠ WARNING

Helical piles are electrically conductive. Avoid contact with underground utilities. Contact between helical pile and underground objects may result in serious injury, death and/or property damage. Before installing the helical pile, determine the location of all underground utilities (electric, gas, water, sewer, telephone, CATV, etc.) to prevent accidental helical pile contact or puncture.

For 2 and 3 helix piles, the Lead Section should be started farther from the foundation than a single helix pile. In addition, the pile shaft should initially be at a greater angle (up to 10 degrees from vertical). When the upper most helix has been installed below the foundation, Extensions may be added for additional leverage, but the Lead Section must be forced against the foundation. At this point, the Lead Section shaft with the helices must be at 3-5 degree angle from vertical with the shaft as close to the foundation as possible. If this is not achieved, you must remove the pile and restart the process.

NOTE: It may be difficult or impossible to correctly install (the shaft at 3-5 degrees from vertical with the shaft as close to the foundation as possible) multi-helix piles with portable installation equipment. It is recommended to use power equipment such as a mini excavator to install multi-helix piles.

6. With the helical pile at 3-5 degrees, begin the installation by applying both down pressure and rotational torque to the pile. Once the pile has begun penetrating the soil, down pressure should no longer be required. Continue to drive the Helical Pile at 3-5 degrees from vertical. As Extensions are added, shaft Coupling Bolts should be tightened ¼ turn past hand tight. Add Extension shafts as necessary until the predetermined torque has been obtained. This predetermined torque should be maintained for at least the final 3 feet (1 m) of penetration before stopping the installation.

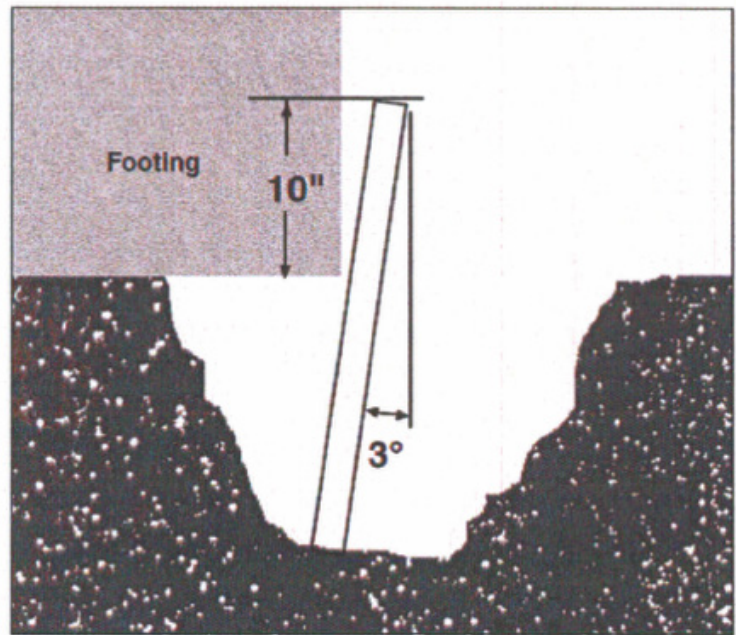
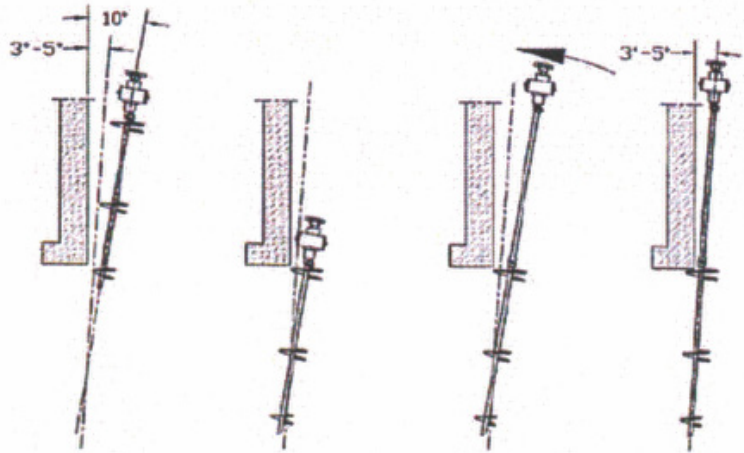

7. The Helical Pile Shaft should be terminated or cut off 10" (254 mm) above the cleaned and prepared footing. A portable band saw may be used to cut the shaft at the required elevation.
8. To install the Bracket that connects the Helical Pile to the foundation, slide the fully disassembled Bracket sub-assembly down the Helical Pile shaft to the bottom of the excavated hole. Then, slide the T-Pipe over the Square Shaft Helical Pile or inside the 2-7/8" (73 mm) Round Shaft. Install the Lifting Bolts into the T-Pipe. Lift the Bracket using the Lifting Bolts, again making sure the Bracket is seated flush with the foundation.
9. Check to see that the T-Pipe is all the way down on the Helical Pile shaft; gently tapping the top of the T-Pipe (a hammer may be required). The Pipe Support Arm located on the bottom of the Bracket body must be seated snugly against the T-Pipe.
10. Drill two holes into the foundation using the Mounting Bolt slots of the Bracket as a drill guide. Follow the directions of the anchor bolt manufacturer when installing the anchor bolts. The underpinning bracket requires 2, 5/8" (16 mm) Anchor Bolts, each with 10,700 lbs (2,400 kN) of ultimate tension capacity.
11. Attach the appropriate jacking tool to the top of the Lifting Bolts. The Lifting Bolts are installed from the bottom, up - through the Bracket, through the T-Pipe, Washer and Square Nut. There must be at least 1" of Lifting Bolt thread above the Square Nut for adequate thread engagement with the jacking tool.

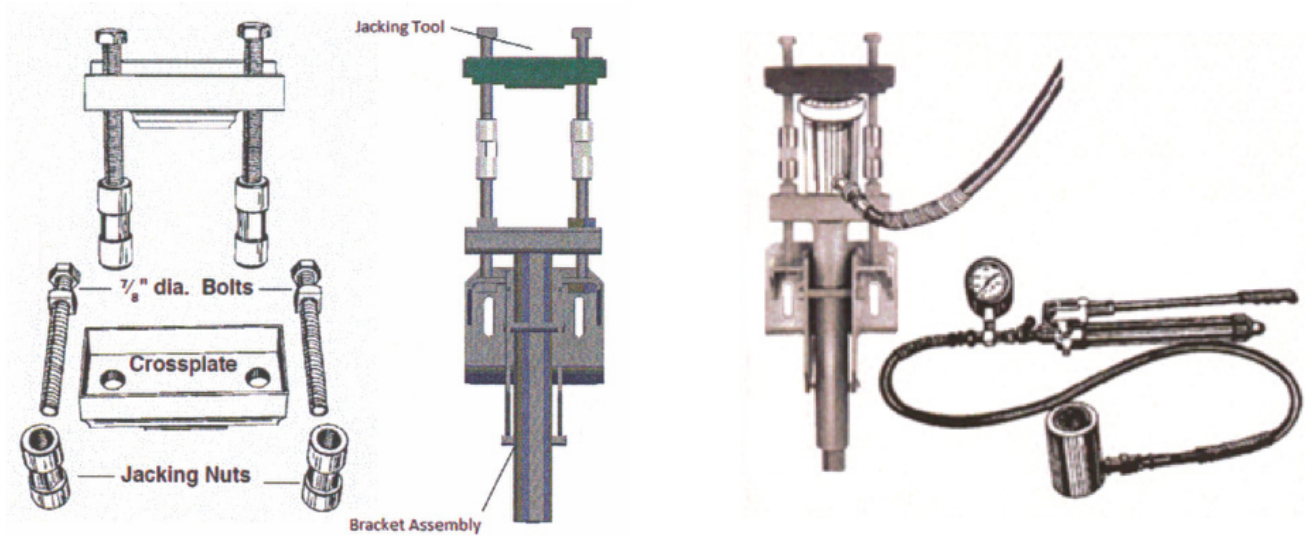

12. Place the jack or hydraulic cylinder between the T-Pipe and the Cross-Plate on the jacking tool. Adjust the height of the jacking tool as required to meet the height of the jack.
13. Apply a small amount of pressure to the jack, just enough to take up the "slack" in the assembly. Once again, check to see if the bracket is still mounted flush with the foundation.

⚠ WARNING

Potential for structural collapse. Can cause property damage, personal injury or death. Do not raise the foundation unless the necessary structural considerations have been made. Structural integrity of the foundation must be determined by qualified personnel before lifting or stabilizing. A plan of repair must be made and followed to prevent overloading of the foundation, helical pile or bracket.

14. More pressure can now be applied to the jack to lift or stabilize the structure. Always use a jack with a pressure gauge in order to monitor the lifting force. A manifold system can allow control of the hydraulic pressure on multiple jacks/ cylinders simultaneously and greatly assist during a lifting procedure. The Square Nuts on the Lifting Bolts that tighten against the T-Pipe Cross Bar, should be tightened frequently during the jacking process. This transfers load to the Bracket body. Set up reference points on the foundation to monitor movement both inside and outside the structure.
15. Once lifting or stabilizing the structure is complete, tighten the square nuts on the Lifting Bolts against the T-Pipe Cross Bar.
16. When the nuts on the Lifting Bolts are tight, release the pressure from the jack. Remove the jack and jacking tool before backfilling the hole.

For Bracket and T-Pipe Ratings, see next page

CHANCE® Helical C1500934 Standard Bracket & T-Pipe Ratings

These products must be installed by CHANCE certified dealers, trained to install the CHANCE Helical Pile System and Maximum Pile Spacing.

T-Pipe Catalog Numbers for the C1500934 Bracket	Ultimate Mechanical Strength lbs (kN)	Pile Size Inches (mm)	Product Series	Max Working Capacity based on Product Series lbs (kN)
C150-0486	30,000 (134)	1 1/2 (38) Square	SS5 SS150	15,000 (67)
C278-0001	30,000 (134)	2 7/8 (73) Round	RS2875.203	15,000 (67)
C278-8012	30,000 (134)	2 7/8 (73) Round	RS2875.276	15,000 (67)

NOTES:

- Ultimate Mechanical strength is for the Bracket Body and T-Pipe combination.
- The capacity of the CHANCE® Helical Pile System is a function of many individual elements, including the capacity of the foundation, bracket, pile shaft, helix plate and bearing stratum, as well as the strength of the foundation-bracket connection and the quality of the helical pile installation. The fifth column shows typical working capacities of the CHANCE® Helical Pile System based upon maximum shaft exposure of 2 feet and soil strength having a minimum Standard Penetration Test (SPT) Blow Count “N” of 4. Actual capacities could be higher or lower depending on the above factors.
- The ultimate capacity of the system, i.e., bracket, T-Pipe and pile shaft, can be increased to the pile shaft compression capacity limit as shown in the CHANCE® Technical Design Manual provided the pile shaft is reinforced using a pipe sleeve or grout column. The maximum working capacity shall not be greater than one half the ultimate mechanical strength of the bracket and T-Pipe combination given above.





CHANCE Civil Construction | Hubbell Power Systems, Inc. | hubbellpowersystems.com/abchance

©Copyright 2017 Hubbell Incorporated. Because Hubbell has a policy of continuous product improvement, we reserve the right to change design and specifications without notice.



Printed in the U.S.A. | TD_04_210_E