

CHANCE® Type RS3500.300 Helical Piles per ICC-ES AC358 for Building Code Evaluation

87.5 kip Ultimate – 43.75 kip Allowable Capacity
 Installation Torque Rating – 12,500 ft-lb

Multi-Purpose 3-1/2" Diameter, 0.300" Wall, Round HSS Shaft with Welded Sleeve Coupling

Description:

Hubbell Power Systems, Inc., CHANCE Type RS3500.300 Helical Piles have 87.5 kip ultimate capacity and 43.75 kip working or allowable capacity in compression or tension. This capacity is based on well documented correlations with installation torque, which is recognized as one method to determine capacity per IBC Section 1810.3.3.1.9. Lead sections and extensions couple together to extend the helix bearing plates to the required load bearing stratum. Round shaft helical piles offer increased lateral and buckling resistance compared to solid square shafts with similar torque strength. Strength calculations are based on a design corrosion level of 50 years for most soil conditions. CHANCE Type RS Helical Piles can be coupled with square shaft lead sections (Combo Piles) to provide greater penetration into bearing soils. CHANCE Type RS Helical Piles and Anchors feature sharpened leading edge helix plates that are circular in plan to provide uniform load bearing in most soil conditions. Helix plates can be equipped with "sea-shell" cuts on the leading edge to enhance penetration through dense soils with occasional cobbles and debris. Custom lengths and helix configurations are available upon request. See below for additional information and other sections of this Technical Manual for specifications and design details.

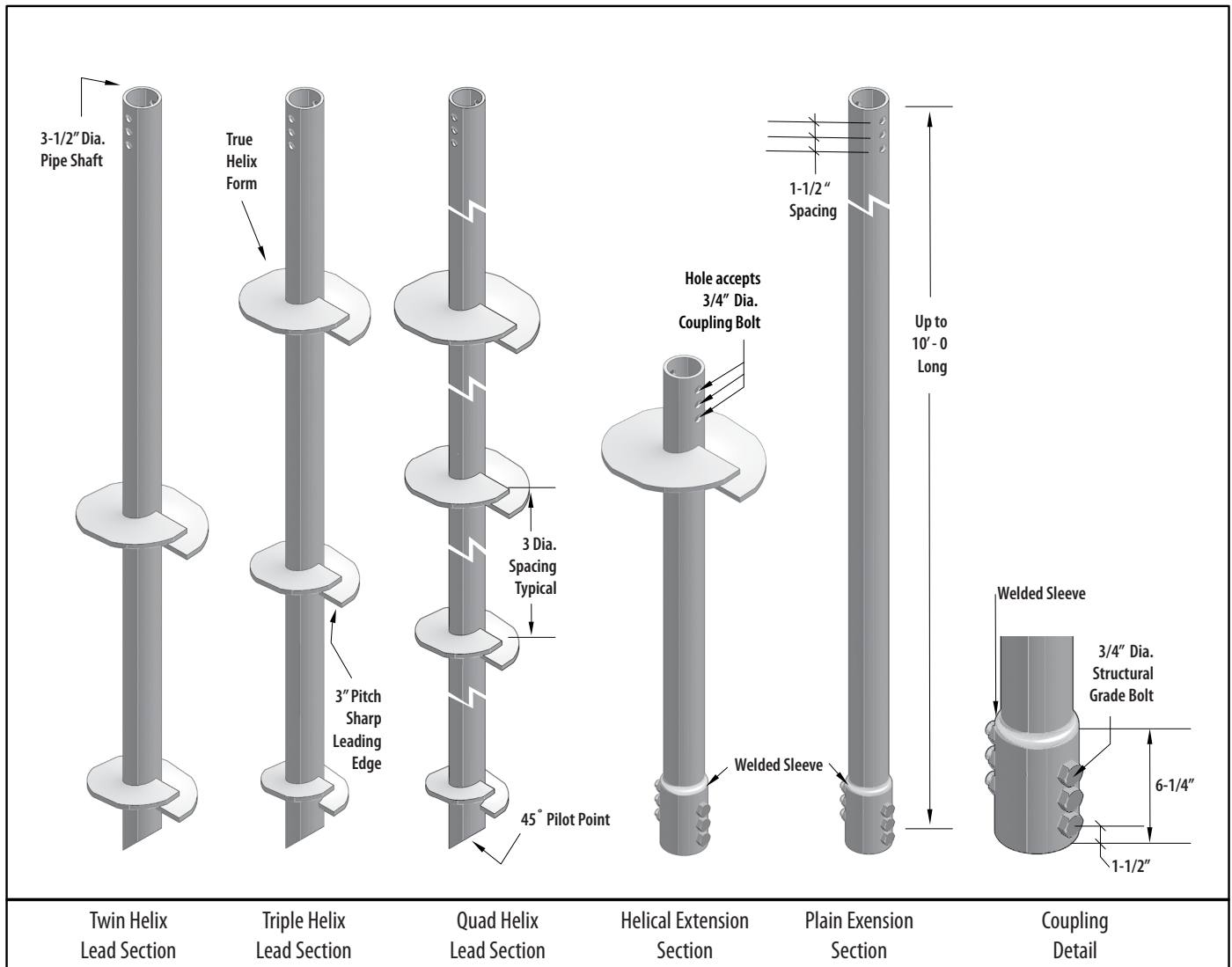

RS3500.300 Building Code Helical Pile Specifications & Available Configurations

Shaft - HSS 3-1/2 inch OD x 0.300 inch (schedule 80) wall steel shaft produced exclusively for CHANCE products.

Coupling - Welded sleeve forming a socket connected with multiple structural bolts.

Helix - 1/2 inch Thick: ASTM A572, or A1018, or A656 with minimum yield strength of 50 ksi.

3 inch Helix Pitch - a Standard established by Hubbell Power Systems, Inc. for CHANCE Helical Piles and Anchors.

Available Helix Diameters: 8, 10, 12, or 14 inches.

All helix plates are spaced 3 times the diameter of the preceding (lower) helix unless otherwise specified.

The standard helix plate has straight sharpened leading edges or can be ordered with a "sea shell" cut. The "sea shell" cut is best suited when it is necessary to penetrate soils with fill debris, cobbles, or fractured rock.

Configurations:

Single, double, triple, and quad helix Lead Sections, 3, 5, 7, and 10 feet long

Plain Extensions, 3, 5, 7, and 10 feet long

Extensions with Helix Plates, 3-1/2 7 and 10 feet long

Helical products are Hot Dip Galvanized per ASTM A123 Grade 75.

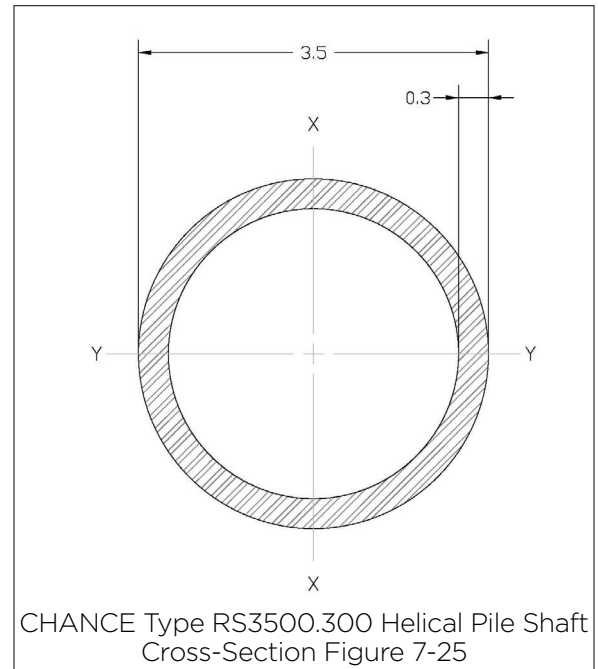

NOTE: Helical piles shall be installed to appropriate depth in suitable bearing stratum as determined by the geotechnical engineer or local jurisdictional authority. Torque correlated capacities are based on installing the pile to its torque rating, using consistent rate of advance and RPM. A minimum factor of safety of 2 is recommended for determining allowable capacity from correlations. Deflections of 0.25 to 0.50 inches are typical at allowable capacity.

Nominal, LRFD Design and ASD Allowable Strengths of RS3500.300 Helix Plates for Shaft Axial Tension and Compression¹

Helix Diameter in (mm)	Thickness in (mm)	Nominal Strength kip (kN)	LRFD Design Strength kip (kN)	ASD Allowable Strength kip (kN)
8 (200)	0.5 (13)	141.1 (627.6)	105.8 (470.7)	70.6 (314.0)
10 (250)	0.5 (13)	155.1 (689.9)	116.3 (517.4)	77.6 (345.2)
12 (300)	0.5 (13)	159.6 (709.9)	119.7 (532.4)	79.8 (354.9)
14 (350)	0.5 (13)	139.4 (620.1)	104.6 (465.1)	69.7 (301.1)

For SI: 1 kip = 4.448 kN.

¹Capacities based on a design corrosion level of 50-years.

Nominal and LRFD Design Compression Strengths of CHANCE® Type RS3500.300 Helical Pile Lead & Extension Sections^{1,2,3}

Section Type & Helix Count	Nominal & LRFD Design Compression Strengths kips (kN)							
	Firm Soil				Soft Soil			
	Fixed		Pinned		Fixed		Pinned	
	Nominal	Design	Nominal	Design	Nominal	Design	Nominal	Design
Lead, Single Helix	128 (569.4)	115 (512.4)	121 (542.2)	109.7 (488.0)	110 (489.3)	99.0 (440.3)	90.7 (403.5)	81.6 (363.0)
		See Helix Strength Table for single 8" & 14"		See Helix Strength Table for single 8" & 14"				
Lead, Multi-Helix	128 (569.4)	115.2 (512.4)	121 (542.2)	109.7 (488.0)	110 (489.3)	99.0 (440.3)	90.7 (403.5)	81.6 (363.0)
Extension	128 (569.4)	115.2 (512.4)	121 (542.2)	109.7 (488.0)	110 (489.3)	99.0 (440.3)		

For SI: 1 kip = 4.448 kN.

¹ Refer to Section 4.1.3 of ESR-2794 for descriptions of fixed condition, pinned condition, soft soil and firm soil.

² Strength ratings are based on a design corrosion level of 50-years and presume the supported structure is braced in accordance with IBC Section 1808.2.5, and the lead section with which the extension is used will provide sufficient helix capacity to develop the full shaft capacity.

³ Nominal strengths are limited to 100 kip (444.8 kN) per AC358 Section 3.8.

RS3500.300 HELICAL PILE AND ANCHOR PRODUCT SPECIFICATIONS

SHAFT	Hot Rolled HSS 3 inch Nominal Schedule 80 (0.300 inch nominal wall) per ASTM A500 Grade B/C with 50 ksi minimum yield strength			
Shaft Size, OD	3.5 in	89 mm	Corroded	
			3.487 in	63.2 mm
Shaft Size, ID*	2.942 in	74.7 mm	Corroded	
			2.955 in	75.1 mm
Moment of Inertia (I)*	3.69 in ⁴	153.6 cm ⁴	Corroded	
			3.514 in ⁴	146.3 cm ⁴
Shaft Area (A)*	2.82 in ²	18.2 cm ²	Corroded	
			2.692 in ²	17.4 cm ²
Section Modulus (S _{x-x})*	2.11 in ³	34.5 cm ³	Corroded	
			2.016 in ³	33.0 cm ³
Perimeter	11.0 in	27.9 cm	Corroded	
			10.95 in	27.8 cm
Coupling	Welded Round Deep Socket			
Coupling Bolts	Two ¾ in Dia. SAE J429 Grade 5 Hex Head Bolts with Threads Excluded from Shear Planes			
Helix Plates	0.5 inch Thick, Formed on Matching Metal Dies, ASTM A572 Grade 50 or better			
Coatings	Hot Dip Galvanized per ASTM A123 Grade 75, 3.0 mil minimum thickness or Bare Steel			
TORQUE PROPERTIES				
Torque Correlation Factor	7 ft ⁻¹		23 m ⁻¹	
Torque Rating	12,500 ft-lb		16,947.7 N-m	
STRUCTURAL CAPACITY				
Tension Strength	Nominal		LRFD Design	
	100 kip	444.8 kN	86.1 kip	383.0 kN
Allowable Tension Strength	57.4 kip		255.3 kN	
TORQUE CORRELATED CAPACITY				
Capacity Limit Based on Torque Correlation, Tension / Compression	Ultimate		Allowable	
	87.5 kip	389.2 kN	43.75 kip	194.6 kN

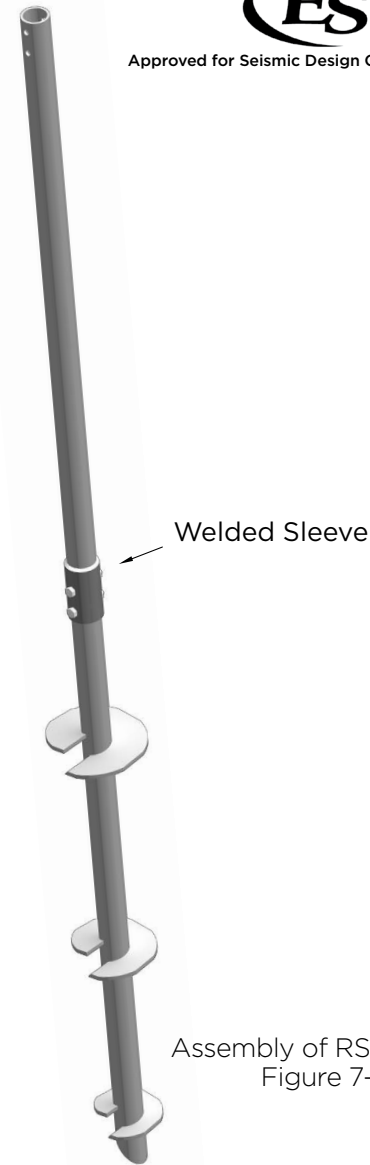
 Assembly of RS3500.300
Figure 7-26

* computed with 93% of wall thickness per AISC 360-10, B4.2

ASD Allowable Compression Strengths of CHANCE® Type RS3500.300 Helical Pile Lead & Extension Sections^{1,2,3}

Section Type & Helix Count	ASD Allowable Axial Compression Strength kips (kN)			
	Firm Soil		Soft Soil	
	Fixed	Pinned	Fixed	Pinned
Lead, Single Helix	See Helix Strength Table for single 8" & 14"	See Helix Strength Table for single 8" & 14"	65.9 (293.1)	54.3 (241.5)
	76.6 (340.7)	73.0 (324.7)		
Lead, 2-Helix 8"-10"	76.6 (340.7)	73.0 (324.7)	65.9 (293.1)	54.3 (241.5)
Lead, 2-Helix 10"-12"				
Lead, 2-Helix 12"-14"				
Lead, 2-Helix 14"-14"				
Lead, Multi-Helix	76.6 (340.7)	73.0 (324.7)	65.9 (293.1)	54.3 (241.5)
Extension	76.6 (340.7)	73.0 (324.7)	65.9 (293.1)	54.3 (241.5)

For SI: 1 kip = 4.448 kN.

¹ Refer to Section 4.1.3 of ESR-2794 for descriptions of fixed condition, pinned condition, soft soil and firm soil.

² Strength ratings are based on a design corrosion level of 50-years and presume the supported structure is braced in accordance with IBC Section 1808.2.5, and the lead section with which the extension is used will provide sufficient helix capacity to develop the full shaft capacity.

³ ASD allowable strengths are limited to 60 kip (266.9 kN) per AC358 Section 3.8.