

OPERATING INSTRUCTIONS

CHANCE® WIRELESS TORQUE INDICATOR WITH WIRELESS TORQUE DISPLAY

C3031689



⚠ WARNING
Read all instructions, warnings, and cautions before operating these devices. Failure to do so could result in voided warranty, property damage, serious injury, or death.



The CHANCE® Wireless Torque Indicator and CHANCE® Wireless Torque Display are designed for use in installation of CHANCE® screw anchors/piles in soils. These instructions are intended to illustrate the proper use of the C3031689 Wireless Torque Indicator and Wireless Torque Display (available separately as C3031723). Anchor installation tools covered in these instructions should be used by competent personnel familiar with and following good work and safety practices. These instructions are not intended as a substitute for adequate training and experience in safe procedures for this type of equipment.

INSTALLATION

The torque indicator is installed between a CHANCE® Kelly bar adapter and anchor drive tool or locking dog adapter, using the bolts and lockwashers provided with the torque indicator. To prevent binding and possible damage to the bolts, follow these procedures when installing or removing a Kelly bar adapter or drive tool:

- When installing, thread in all of the bolts until they are snug against the lockwashers then tighten them to the torque specified in the table below.
- When removing, loosen all of the bolts about 1/2 turn then remove the bolts.

⚠ CAUTION
Failure to follow the proper procedure for installation or removal of the bolts may result in damage to the bolts and render them unusable.

If bolts or lockwashers become worn or damaged after extended use, they should be replaced. Replacement bolts should be of the same size, length, and grade as the originals. Catalog number C3031757 is available as a complete package of all bolts and lockwashers. Be sure to use the appropriate adapters and bolts for the maximum installation torque to be transmitted. All CHANCE® screw anchor installation tools are torque rated. Mounting bolts and bolt tightening torques for anchor installation torque ranges are shown below:

| Maximum Torque (ft-lb) | Bolt Circle Diameter (in) | Bolts with Lockwashers | | | |
|------------------------|---------------------------|------------------------|----------------|----------------|---------------------|
| | | Total Required | Bolt Size (in) | SAE J429 Grade | Bolt Torque (ft-lb) |
| 10,000 | 5-1/4 | 12 | 1/2 | 5 | 75 |
| 30,000 | 7-5/8 | 24 | 5/8 | 5 | 95 |

⚠ WARNING
Loose parts may be thrown at high speed. Can cause property damage, serious injury or death. Use installation tooling and mounting bolts with strength ratings higher than anchor installing torque.

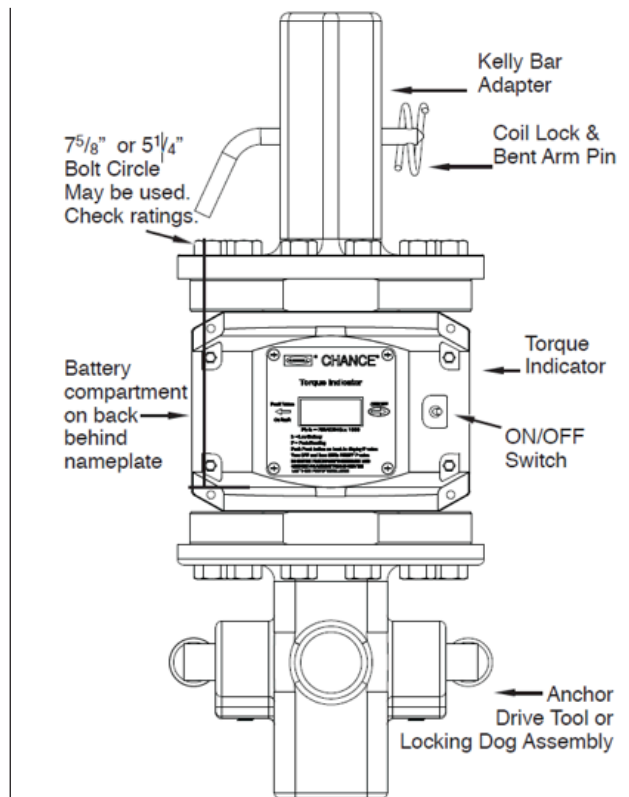

Attach Kelly bar adapter to top and anchor drive tool or locking dog assembly to bottom of torque indicator as described above. Align the Kelly bar adapter with the Kelly bar so that the cross pin holes will match up and slide the Kelly bar adapter onto the Kelly bar. Secure in place with the bent arm pin and coil lock provided with the Kelly bar adapter.

⚠ WARNING
Loose parts may be thrown at high speed. Can cause property damage, serious injury or death. Use only the proper size CHANCE® bent arm pins and coil locks for cross-pin attachment of Kelly bar adapters to Kelly bars and anchors to drive tools.



WIRELESS TORQUE INDICATOR FEATURES

- Radio communication range of at least 50 ft
- Can have links with multiple CHANCE® Wireless Torque Data Loggers and/or Wireless Torque Displays simultaneously
- Sealed for weather resistance
- Can withstand drop from 6 ft
- Operating temperature range of -22 F (-30 C) to 158 F (70 C)
- ON/OFF push button on front of indicator
- MODE push button on back of indicator
 - Displays Peak torque measured since indicator last turned on
 - Displays cumulative number of torque cycles since last calibration
- Integral high-visibility 4 digit LCD screen
- Replaceable scratch/impact resistant screen protector; one spare included, extras available from Bevins Co.
- Torque displays from 500 ft-lb to 30,000 ft-lb in 100 ft-lb increments
- Power: One 9V battery; user replaceable
- Low battery warning: “b” displays on left side of screen
- Energy conservation
 - Quiet Mode: Radio transceiver shuts off after 5 minutes of unchanged torque load.
 - Auto Power-Off: Indicator shuts off after 10 minutes of Quiet Mode if torque load remains unchanged.
- GPS for use with Wireless Torque Data Logger
 - Accurate to ~ 20 ft (clear line of sight required for GPS signal reception)
 - Cold Lock: If the indicator has been moved to a new location while powered off, 60 seconds or more may be required to establish a coordinate lock upon initial startup.
 - Hot Lock: If the indicator is moved a short distance after the initial Cold Lock, only a few seconds will be required to establish a coordinate lock.

WIRELESS TORQUE INDICATOR USE

Follow standard installation procedures for the appropriate CHANCE® screw anchor. Before installing the anchor, be sure to turn on the Wireless Torque Indicator by firmly pressing and releasing the ON/OFF push button switch located on the front of the device. The torque indicator will display 0.0 reading when the torque is less than 500 ft-lb. Monitor torque readings during the entire installation to ensure anchor and tooling torque ratings are not exceeded. Remain at a safe distance from the drive train whenever torque is being transmitted, even when taking readings.

⚠ WARNING

Loose parts may be thrown at high speed.
Can cause property damage, serious injury or death.
Stay away from drive train.

The indicator stores the Peak torque value measured since it was last turned on and the number of torque cycles accumulated since its last calibration. (A torque cycle is defined as an increase in torque reading to above 1000 ft-lb and a subsequent return to below 500 ft-lb.) Push and release the MODE button on the back of the indicator at any time when the device is on to view the Peak value and number of cycles. The indicator must be turned off to reset the Peak value. The number of cycles cannot be reset by the user. Hubbell Power Systems recommends the torque indicator calibration be verified once per year or after 5000 torque cycles, whichever is reached first. To predict anchor capacity, use the average torque developed during the last three feet of installation. Do not use the Peak torque value. Relieve all loads (axial, torsional, and bending) on the drive train and check zero setting and bolt tightness after each anchor installation.

⚠ WARNING

Loose parts may be thrown at high speed.
Can cause property damage, serious injury or death.
Monitor the condition of all parts in the drive train and repair or replace as necessary. Check all fasteners along the drive train periodically to ensure they remain tight and undamaged. Loose or damaged bolts may fail at or below rated torque or contribute to damage elsewhere in the drive train. Replacement bolts must be the same size, grade and length as the originals supplied by CHANCE.

Maintain alignment along the drive train. Excessive axial and/or bending forces could affect torque readings. Digging equipment can impose high bending moments on the drive train if alignment is not maintained. This can damage or destroy drive train components.

⚠ WARNING

Loose parts may be thrown at high speed.
Can cause property damage, serious injury or death.
Do not allow bending moments in excess of 6000 lb-ft to develop in drive train.

⚠ CAUTION

Improper use can damage internal parts.
Can render the torque indicator inoperable and will void the warranty.
Do not use in obstruction-laden soil.

The torque indicator is powered by a single 9V battery. To access or replace the battery, remove the nameplate on the back of the indicator. A “b” will display on the left side of the indicator screen when the battery is low. Replace the battery as soon as possible when the low battery warning displays to prevent loss of function.

⚠ CAUTION

Firmly tighten nameplate screws when replacing battery. To prevent stripping of threads, do not overtighten screws. Loose, missing, or stripped screws can compromise the case seal and allow moisture to penetrate the case.

The torque indicator is equipped with energy conservation features to extend the battery life. The indicator will enter Quiet Mode when the torque load has not changed for 5 minutes. When in Quiet Mode, the indicator's radio transceiver is deactivated and radio connections to any linked Wireless Torque Displays or Wireless Torque Data Loggers will be lost. After 10 additional minutes with no change in torque load (15 minutes total), the indicator will Auto Power-Off. If the indicator is in Quiet Mode but still on, a change in the torque load will return it to normal operation and reestablish radio connections. After Auto Power-Off, the indicator must be turned on using the ON/OFF switch.

LINK MODE

To establish a link between a Wireless Torque Indicator and a Wireless Torque Display or Wireless Torque Data Logger, the indicator must be started in Link Mode. Ensure that the indicator is off. Push and hold the MODE button. While holding the MODE button, turn on the indicator. Release the MODE button when "rF.." displays on the indicator screen.

⚠ CAUTION

Do not attempt to establish a link between a torque indicator and multiple other devices simultaneously, as doing so may result in malfunction.

WIRELESS TORQUE DISPLAY FEATURES

- Radio communication range of at least 50 ft
- Linkable to any Wireless Torque Indicator; multiple displays can have links to one indicator simultaneously
- Sealed for weather resistance
- Can withstand drop from 6 ft
- Operating temperature range of -22 F (-30 C) to 158 F (70 C)
- Magnetic back for easy mounting to a wide variety of surfaces
- High-visibility 4 digit LCD screen
- Replaceable scratch/impact resistant screen protector; one spare included, extras available from Bevins Co.
- Power: One 9V battery; user replaceable
- Low battery warning: "b" displays on left side of screen
- Energy conservation
 - Auto Power-Off: Display shuts off after 7-1/2 minutes of no radio connection.

WIRELESS TORQUE DISPLAY USE

Press the ON/OFF button to turn the Wireless Torque Display on. Press and hold the ON/OFF button for 5 seconds to turn it off.

The display is powered by a single 9V battery. To access or replace the battery, remove the battery cover on the back of the display. A "b" will display on the left side of the display screen when the battery is low. Replace the battery as soon as possible when the low battery warning displays to prevent loss of function.

⚠ CAUTION

Firmly tighten battery cover screws when replacing battery. To prevent stripping of threads, do not overtighten screws. Loose, missing, or stripped screws can compromise the case seal and allow moisture to penetrate the case.

The display is equipped with an energy conservation feature to extend the battery life, and will Auto Power-Off when no radio connection is present for 7-1/2 minutes. When there is no radio connection, three dashes (---) will be displayed on the screen. After Auto Power-Off, the display must be turned on using the ON/OFF switch.

LINK PROCEDURE

To link the Wireless Torque Display to a Wireless Torque Indicator, first ensure that the indicator and display are off. Turn on the display to initiate its 60 second link search then start the indicator in Link Mode (see instructions above).

STORAGE

The Wireless Torque Indicator has a sealed case to prevent water penetration during ordinary exposure (i.e., working in rain or snow). The seal will not protect it from long term exposure to the elements or from forced entry of water such as from immersion or highway transportation in the open. It must be stored and transported such that it is protected from water penetration of the case.

⚠ CAUTION

Moisture inside case can damage internal parts. Can render the torque indicator inoperable and will void the warranty. Protect from moisture penetration of case during storage and transportation.

The Wireless Torque Display has a sealed weatherproof case to allow use in all normal work and weather conditions. The seal may provide protection against water penetration during momentary immersion at a shallow depth, but will not protect against penetration from immersion at a significant depth or for a prolonged time.

CAUTION

Moisture inside case can damage internal parts.
Can render the display inoperable and will void the warranty.
Protect from immersion.

The torque indicator and display can be safely stored at temperatures between -22 F (-30 C) and 176 F (80 C). To prevent damage to the indicator and display, do not store at temperatures outside this range.

CAUTION

Exposure to temperatures outside the storage range can damage internal parts.
Can render the devices inoperable and will void the warranty.
Protect from exposure to temperatures outside the specified storage range.

WARRANTY

One year warranty. There are no internal field serviceable parts. Warranty is void if improper use, storage or transportation has occurred or if outer housing or faceplate seal is broken or any internal part removed. For repair or calibration verification, contact Bevins Company
www.bevinsco.com
Office - (918) 627-1273
Fax - (918) 627-1294
9903 E. 54th Street
Tulsa, OK 74146

These instructions do not cover all details or variations in equipment, nor do they provide for all possible conditions to be met with concerning installation, use, maintenance, or storage of this equipment. If further information is desired or if particular problems are encountered which are not sufficiently covered in these instructions, contact Hubbell Power Systems.

Hubbell Power Systems, Inc.
210 N. Allen Street
Centralia, MO 65240
(573) 682-5221
www.hubbellpowersystems.com