



Vantage Technology Junction Box Receptacles

AF/SF, GB and GD Series

ASSEMBLY, TERMINATION and USAGE INSTRUCTIONS

Identification of Principal Parts

Shell Sizes
16 and 20

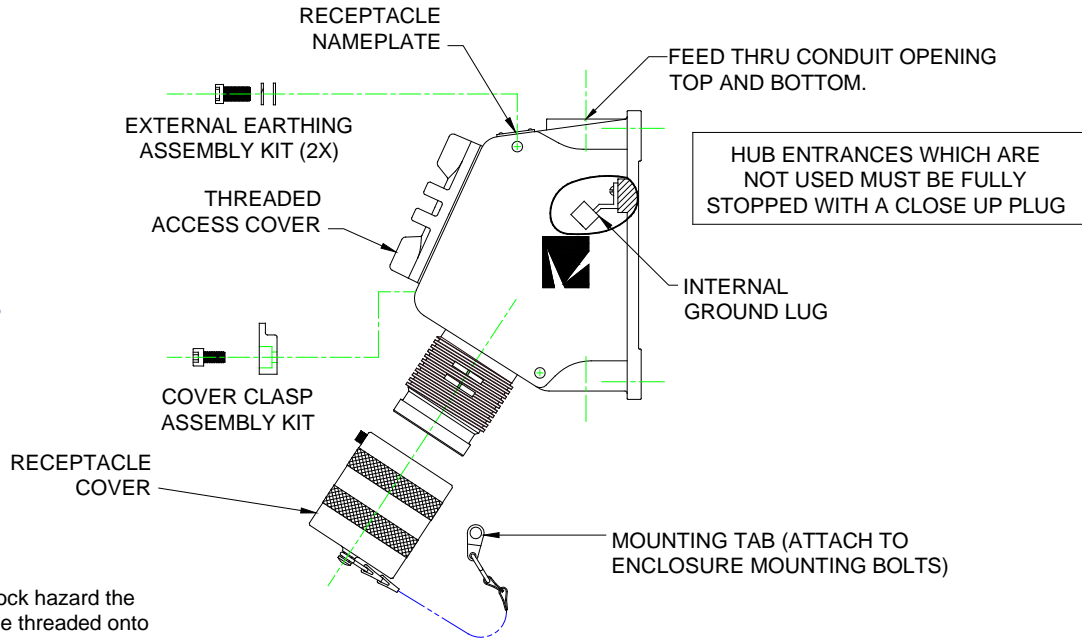

Caution: To prevent shock hazard the receptacle cover must be threaded onto receptacle when receptacle is not in use.

Attention: Pour empêcher le risque de choc, remplacez la couverture de réceptacle quand pas en service.

Shell Sizes
24 and 28

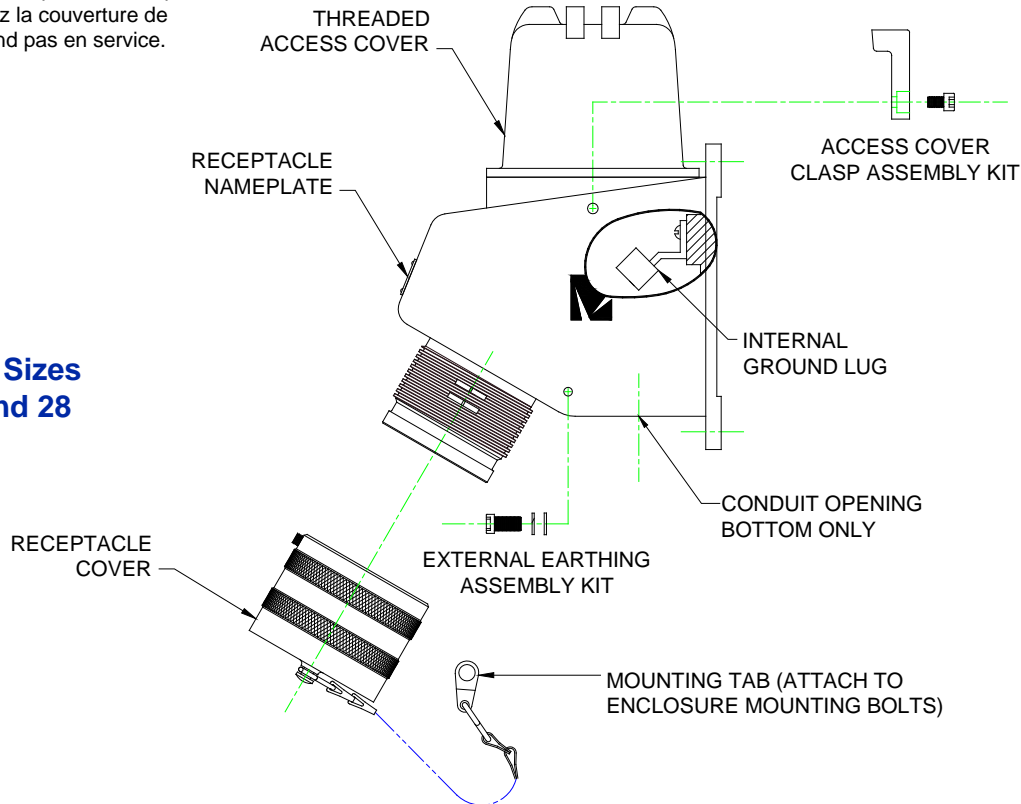

RECAPITULATION OF NAMEPLATE DATA

AF / SF Control Series

FACTORY SEALED RECEPTACLE ASSEMBLY		HAZARDOUS LOCATIONS CLASS I, GROUPS B, C & D CLASS II, GROUPS F & G	
CAUTION: TO PREVENT SHOCK HAZARD, THE RECEPTACLE COVER MUST BE REPLACED UPON REMOVING PLUG FROM RECEPTACLE			
Catalog Number	[REDACTED]		
AMPS CSA	250 Vac Hz 60/400	AMPS ATEX	[REDACTED]
For use with Plug	[REDACTED]		
VANTAGE TECHNOLOGY ENGLEWOOD, COLORADO 80110 U.S.A.	0575 II 2 G D EEx d IIC T6 IP66 T70°C KEMA 04ATEX2179 X 0°C = Ta = +50°C	LISTED RECEPTACLE Class I Zone 1 AEx d IIC, T6 Ex d IIC, T6	CAUTION: KEEP COVER TIGHT WHILE CIRCUITS ARE ALIVE AVERTISSEMENT: GARDER LE COUVERCLE BIEN FERME TANT QUE LES CIRCUITS SONT SOUS TENSION. DO NOT SEPARATE WHEN ENERGIZED NE PAS OUVRIR SOUS TENSION MFG CODE [REDACTED]

*Reference Product Data Sheets for the nameplate data of your
Junction Box receptacle*

Control Series: PDS-AF-SF-JBR

Power Series: PDF-GD-SD-JBR

RECAPITULATION OF NAMEPLATE DATA

GB / SB and GD / SD Power Series

FACTORY SEALED RECEPTACLE ASSEMBLY		HAZARDOUS LOCATIONS CLASS I, GROUP [REDACTED] C-D	
CAUTION: TO PREVENT IGNITION OF HAZARDOUS ATMOSPHERES, DISCONNECT THE SUPPLY CIRCUIT BEFORE OPENING. KEEP TIGHTLY CLOSED WHEN IN OPERATION, OR COVERED WHEN NOT IN USE.			
Catalog Number	[REDACTED]		
AMPS UL-CSA	UL 480V CSA 600V ZONE 600V	60/400 Hz AMPS ATEX	[REDACTED]
For use with Plug	[REDACTED]		
VANTAGE TECHNOLOGY ENGLEWOOD, COLORADO 80110, U.S.A.	0575 II 2 G D EEx d IIC T6 IP66 T70°C KEMA 04ATEX2179 X 0°C = Ta = +50°C	480 VOLT LISTED RECEPTACLE 600 VOLT LISTED RECEPTACLE Class I Zone 1 AEx d IIC, T6 Ex d IIC, T6	CAUTION: TO PREVENT IGNITION OF HAZARDOUS ATMOSPHERES, DISCONNECT THE SUPPLY CIRCUIT BEFORE OPENING. KEEP TIGHTLY CLOSED WHEN IN OPERATION, OR COVERED WHEN NOT IN USE. DO NOT SEPARATE WHEN ENERGIZED NE PAS OUVRIR SOUS TENSION MFG CODE [REDACTED]

Splicing Guidelines, Power Connections

The optimum termination method of source leads to the Vantage receptacle varies with wire size, wire quantity and requirements specific to the installation site. The installer must consider the available box volume when selecting their splice method. The example illustrated in Figure 1 uses a short barrel compression splice to feed a 3P 4W 200 AMP receptacle in a Shell Size 28 junction box. **Caution:** Care must be taken to adequately insulate the splice.

Splicing Methods



Compression
Splices

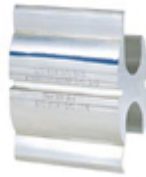

Mechanical
Splice

Notes:

- 1 The example illustrates the use of a 1.44 inch parallel compression splice. Other splicing methods are possible; care must be taken to adequately insulate the splice.
- 2 The receptacle ground lead is pre-terminated and landed onto a ground post. A second ground post and nut is provided for the source ground.
- 3 Splices are crimped as shown.
- 4 Shown is a 4.0 inch length of heavy walled shrink/sleeve. The collapsed sleeve beyond the splice is pinched to close with flat pliers before sleeve/sealant cools and sets. Excess sleeve is then trimmed.
- 5 Completed spliced leads must lie so that they do not interfere with full engagement of junction box access cover.
- 6 Customer supplied leads. Splices must be sized to accommodate both the receptacle leads and the customer supplied leads.

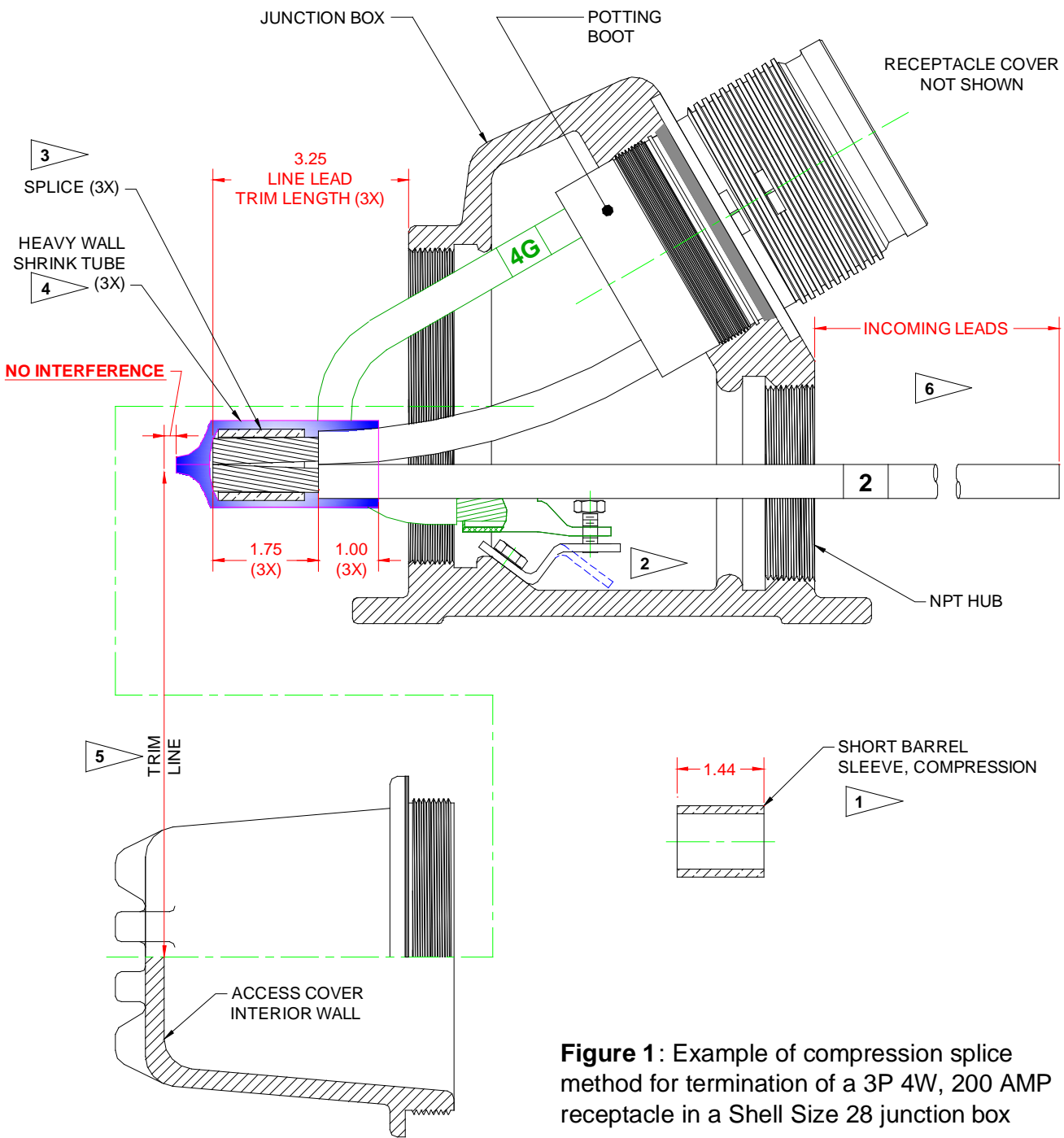

Figure 1: Example of compression splice method for termination of a 3P 4W, 200 AMP receptacle in a Shell Size 28 junction box

Splicing Guidelines, Control Connections

The optimum termination method of source leads to the Vantage receptacle varies with wire size, wire quantity and requirements specific to the installation site. The installer must consider the available box volume when selecting their splice method. The example illustrated in Figure 2 uses vinyl insulated splices to feed a control receptacle in a Shell Size 16 junction box.

Splicing Methods



Compression
Splices

Notes:

- 1 The example illustrates the use of both parallel and end compression splices. Other splicing methods are possible; care must be taken to adequately insulate the splice.
- 2 For control receptacles with a shell ground contact, the ground lead is pre-terminated and landed onto a ground post. This ground lug is designed to accommodate an incoming wire lead. Additional tapped post holes are provided.
- 3 Splices are crimped as shown. Terminate all receptacle leads.
- 4 Splices must be adequately insulated.
- 5 Completed spliced leads must lie so that they do not interfere with full engagement of junction box access cover.
- 6 Customer supplied leads. Splices must be sized to accommodate both the receptacle leads and the customer supplied leads.

Figure 2: Example of compression splice methods for termination of a control receptacle in a Shell Size 16 junction box.

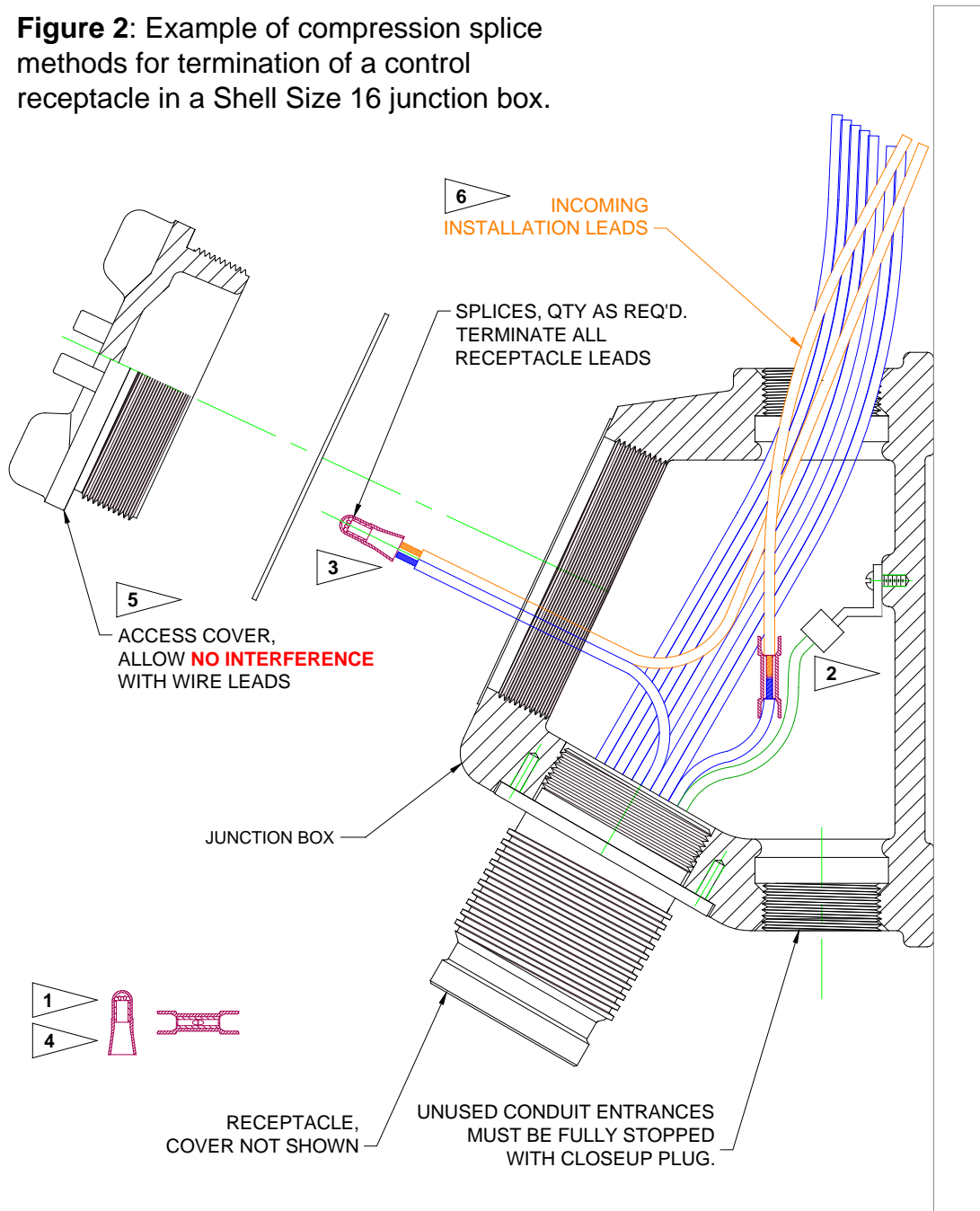

Mounting Dimensions

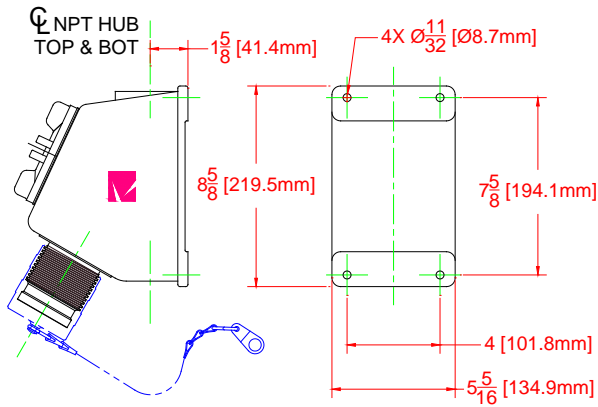

SHELL SIZES 16 AND 20

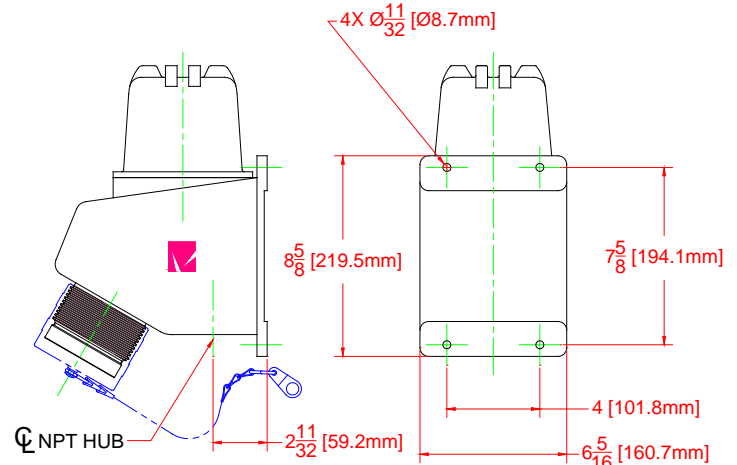

SHELL SIZES 24 AND 28

ENCLOSURE SHELL SIZE	CONDUIT HUB LOCATION	HUB SIZE CODE	CONDUIT HUB SIZE (INCHES)
16 & 20	F = TOB AND BOTTOM	H	1 ½ - 1 ½ NPT
24	B = BOTTOM FEED, TOP FEED NOT AVAILABLE	K	2 ½ - 8 NPT
28	B = BOTTOM FEED, TOP FEED NOT AVAILABLE	L	3 - 8 NPT

Assembly Notes

1. In the event of breaking of sealing compound, receptacle must be returned to factory for resealing. Otherwise, all manufacturing and third party certifications are void.
2. For Shell Size 16 and 20 enclosures hub entrances which are not used must be fully stopped with a close up plug.
3. When conditions require, lubricate coupling threads with silicone oil, Vantage Part Number VT-9400-21D.
4. Use the receptacle cover mounting tab to prevent cover from being lost while receptacle is in use. **Caution:** To prevent shock hazard the receptacle cover must be threaded onto receptacle when receptacle is not in use. **Attention:** Pour empêcher le risque de choc, remplacez la couverture de réceptacle quand pas en service.

Note: Electrical installation shall be in compliance with the National Electric Code (NEC), EN/IEC60079-14, and/or any other presiding local or national electrical code.



4140 World Houston Pkwy, Ste 130
Houston, Texas 77032, USA

Voice 303-761-2121
FAX 281-445-7404
E-mail support@VantageXP.com
Web Site www.VantageXP.com