

Load Control Panel Dimming Switches Installation Instructions



Load:Logic™
Control Panels

Precautions

- **READ AND FOLLOW ALL SAFETY INSTRUCTIONS.**
- **CAUTION:** For use with **Class 2**, low voltage systems only. **Do not** use in high voltage applications.
- All excess cable must be removed from wall box prior to installation. Connection between UTP category rated patch cord and switch connection port must remain straight and true without interference or pressure from excess or misaligned cable.
- **CAUTION - RISK OF ELECTRICAL SHOCK.** To prevent electrical shock, turn OFF power at the circuit breaker before installing or servicing unit. Never wire energized electrical components.
- Be sure to read and understand all instructions before installing or servicing unit
- For Indoor use only. Do not use outdoors.
- Disconnect switch or a circuit breaker must be provided and marked as the disconnecting device.
- The use of accessory equipment not recommended by the manufacturer may cause an unsafe condition.
- Confirm that device ratings are suitable for application prior to installation.
- No user serviceable parts contained inside unit. Refer all service related questions to the factory.
- All servicing shall be performed by qualified service personnel.
- **NOTICE:** Do not install if product appears to be damaged.
- If the equipment is used in a manner not specified by the manufacturer, the protection provided by the equipment may be impaired.
- Do not use this equipment for other than intended use.

SAVE THESE INSTRUCTIONS!



Description

While the Hubbell Wiring Device-Kellems load control panel dimming switches can be used to control switched loads, groups, and presets as well as dimmers, they are intended for use with the Load Control Dimming Card Option catalog number CPDM8CTRB installed in the panel. Rather than having fixed functionality, buttons on the switches are programmable and can each be used for a variety of control functions. Both the switch station and the panel require programming for use of the switches.

Installation

- Prepare the installation site as necessary. Switches may be installed in a single gang box or ganged into a multi-gang box.
- Since the dimming card has only four (4) RJ45 input jacks, some installations will require switches to be wired in daisy chained in order to achieve the desired functionality. Plan ahead before running the UTP category based patch cords for the switches.
CAUTION: Ensure that UTP category based patch cords (patch cords) are plenum rated if there are cable runs through a plenum classified space.
- Plug the patch cord into either RJ45 connector on the back of the switch. Remove excess wire from the box so that undue pressure is not exerted on the switch when it is inserted into the box. See **Figure 1**.
- Plug the other end of the patch cord into the appropriate RJ-45 jack on the Dimming Option Card in the panel.
- For connecting two or more switches in one box, use the supplied 3" patch cord between switches. See **Figure 2**.
- Do not install a cover plate on the switch until it has been programmed.



Figure 1



Figure 2

Programming the Switches

The process of programming the switch is simple and straight forward. It does not require any special tools or software. The actual lighting control features to be performed by each button will be programmed at the panel. There are 6 control lines (wires) physically in the patch cord used with the switch. The switch programming simply determines which of the 6 wires (A-F) that the button will affect when pressed.

- The switch must be properly connected to the panel dimming option card and the panel must be powered up to program the switch.
- Remove the plastic switch bezel that surrounds the buttons. Use a small screw driver or similar to pry the bezel from the switch housing using the detent in the housing at the bottom of the bezel. See **Figure 3**.
- Locate the programming button marked "config" along the right side of the printed circuit board near the center.
- Locate an array of 6 LEDs on the printed circuit board above the "config" button. While not physically labeled, these represent lines A - F beginning with A at the top.
- Press and release the "config" button. All 6 LEDs will begin to blink.
- Press one of the control buttons. Note that only one of the LEDs will be illuminated. Tap the control button to advance the position of the illuminated LED. Stop when the LED representing the desired control line A - F is illuminated. Repeat for each button on the station.
- Press the "config" button for 2 seconds to exit the programming mode and save the program.
- After completing the programming and exiting the program mode, press each control button and observe that the proper LED indicator illuminates when the button is pressed.
- If the button does not control the proper line when pressed, repeat the programming process above.
- Some switch models are supplied with alternate button caps for use with various functions. To change the button cap, carefully pull the button cap straight off the switch. Do not twist or flex the button shaft. Carefully press the new button cap onto the shaft.
- Re-install the switch bezel by inserting the top tabs into the slots in the housing then pressing the lower tabs into their slots. Note that the openings and legends around the edges of the bezel are not used on this assembly and have no function.
- Install a standard face plate on the switch (not supplied).
- Complete the programming of the panel per the project requirements.

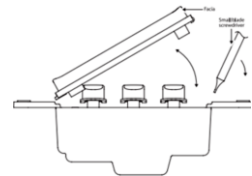

Figure 3

UTP Patch Cords Interconnections

Typically, lines A, B, C, and D will be used for Raise/Lower dimming control. Lines E and F can be used to provide ON/OFF for a relay associated with a dimmer. If using more than four (4) dimmers on a dimming option card, it will be necessary for some or the entire patch cord runs to control two dimmers. See **Figure 4**. Plan cable home runs accordingly. Multiple switch stations with the same configuration can be connected in daisy chained on a single run of patch cords to provide additional control locations. See **Figure 6**. The drawing below illustrates the use of the six (6) control lines:

Figure 4

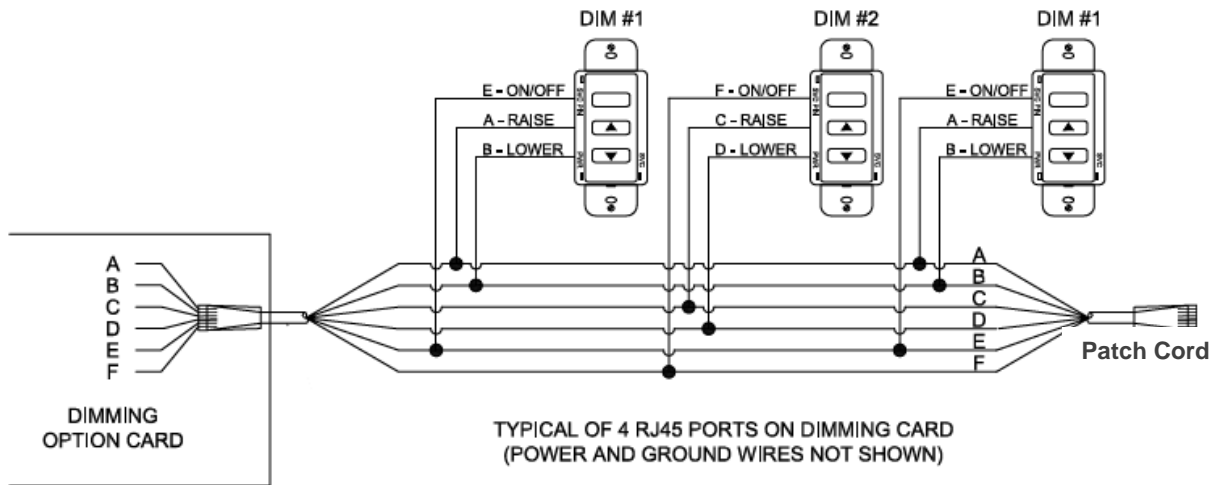
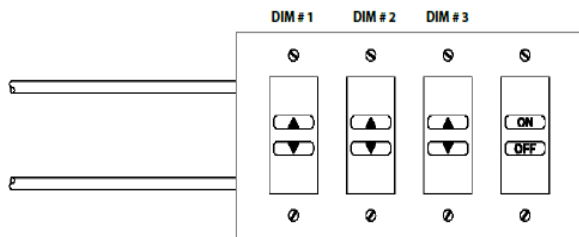
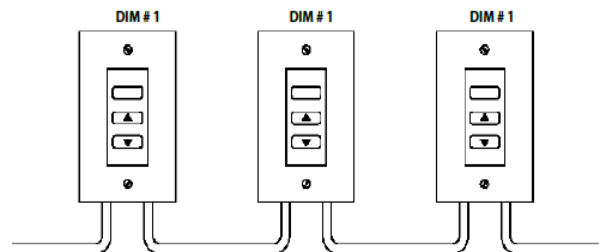

Figure 5



Switch locations controlling more than two dimmers will require additional patch cords home runs.

Figure 6



Switch stations with similar functions can be daisy chained.

Specifications

- Wiring is Class 2, UTP category based with RJ-45 connectors.
- Powered by the panel through the dimming option card RJ-45 connector.
- Use standard decorator style line face plate (not included).
- For indoor use only.
- Five year limited warranty.