

SECTIONS

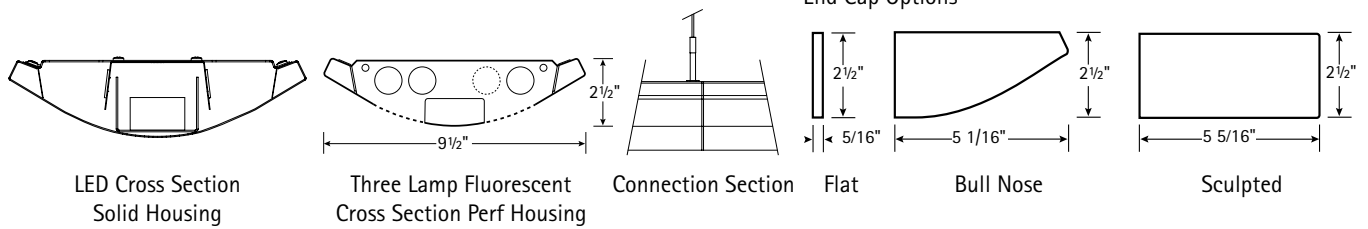

BOTTOM VIEW

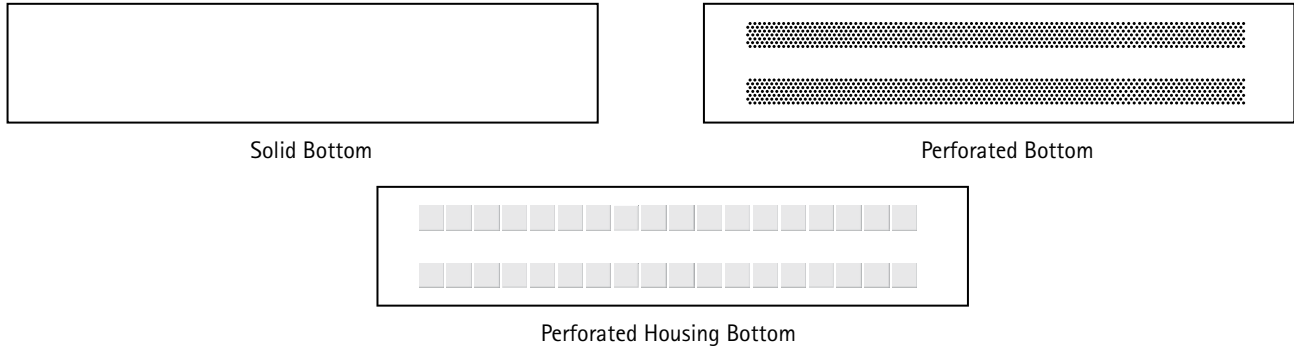

SINGLE MOUNTING (INCLUDING FLAT END CAPS)

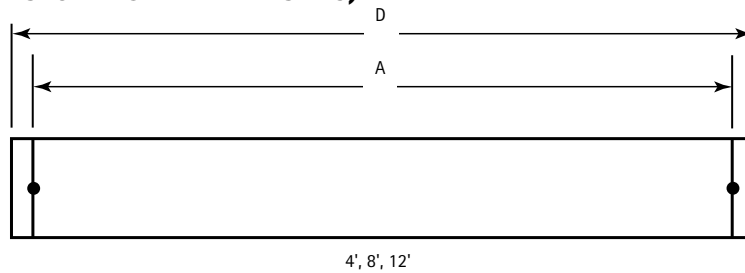

ROW MOUNTING (INCLUDING FLAT END CAPS)

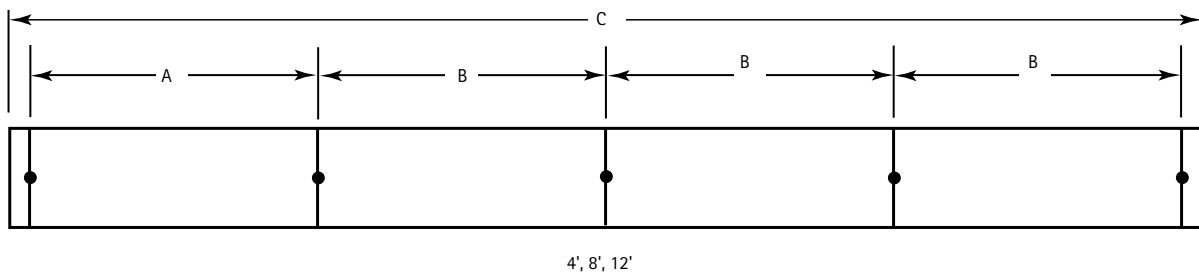

DATA CHART

Nominal Length	Approx. Weight				A	B	C	D
	1-lamp	2-lamp	3-lamp	LED				
4'	13.3 lbs.	15.6 lbs.	17.9 lbs.	17.1 lbs.	47 1/4"	48"	192 5/8"	48 5/8"
8'	25.3 lbs.	27.6 lbs.	29.9 lbs.	28.6 lbs.	95 1/4"	96"	384 5/8"	96 5/8"
12'	34.5 lbs.	39.1 lbs.	41.4 lbs.	40.1 lbs.	143 1/4"	144"	576 5/8"	144 5/8"

Note: Suspension data is computed using the standard aircraft cable assembly. The use of rigid stems will yield different data. Please consult factory for stem data.

FIXTURE CONNECTIONS

Connection Instructions:

1. Install first fixture of row with two hangers.
2. Slide inner die cast plates together.
3. Secure fixture joints with two bolts and nuts and attach hanger at opposite end.
4. Repeat steps 2 and 3 until row is complete.
5. At each end of the row, attach and align end cap with two screws.

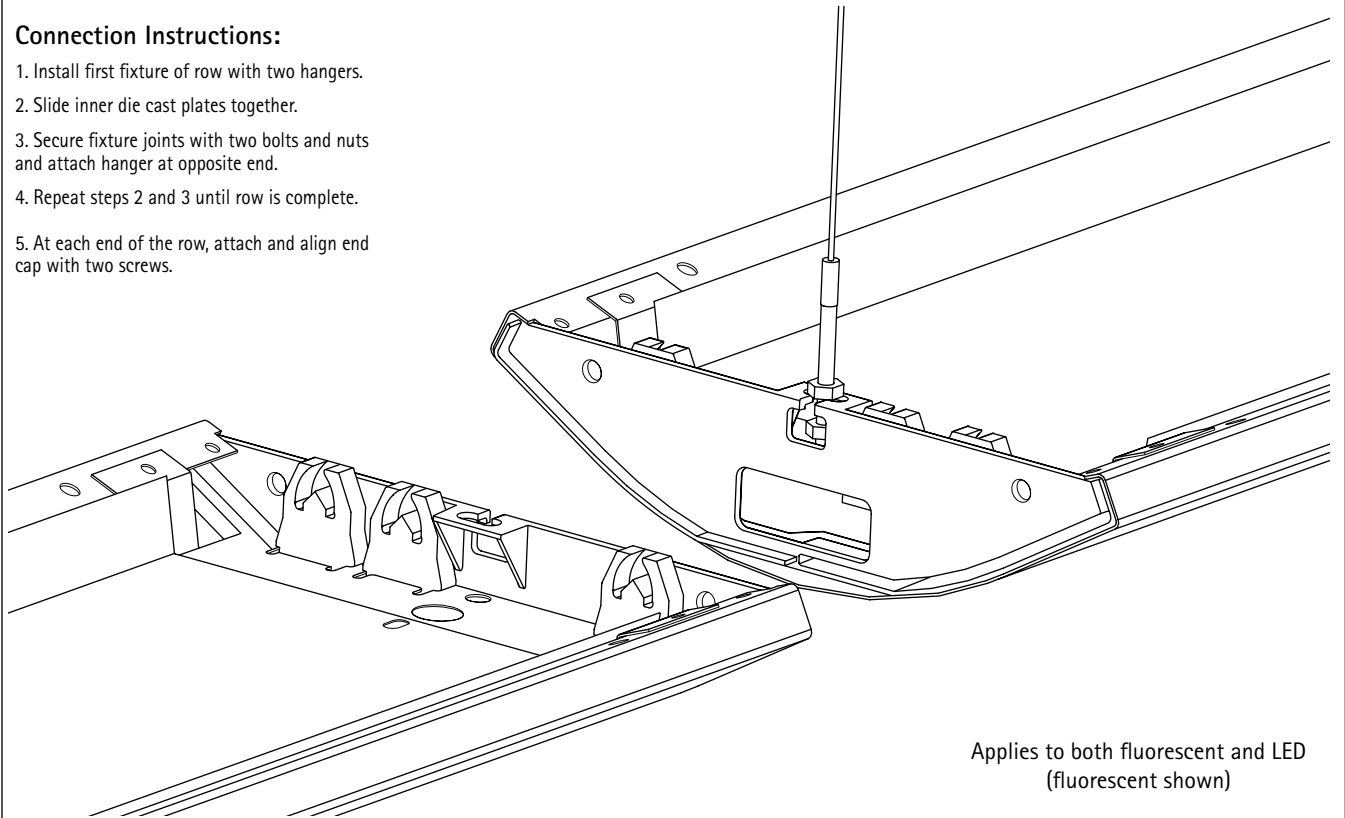

SUSPENSION ATTACHMENT

Suspension Instructions:

1. Set bottom nuts to desired fixture height.
2. Adjust upper nuts for a minimum of $\frac{3}{8}$ " between upper and lower nuts.
3. Slide cable hanger into hanger slots.
4. Secure and tighten upper nuts.

