

SECTIONS

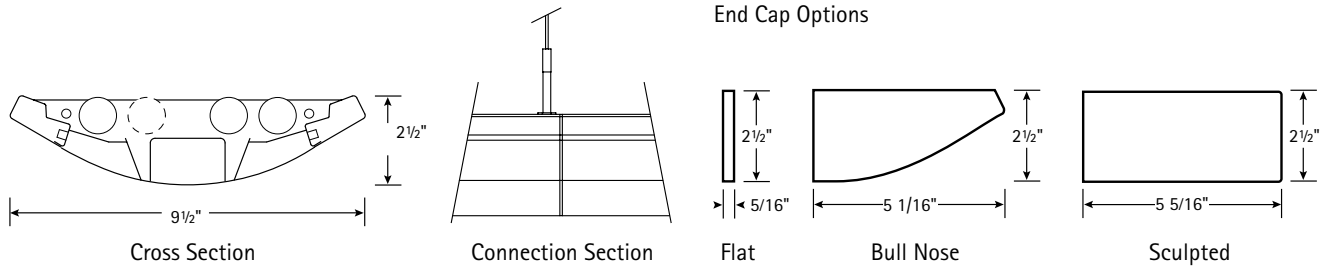

BOTTOM VIEW

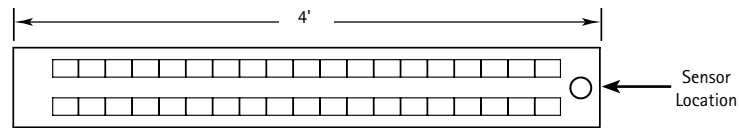

SINGLE MOUNTING

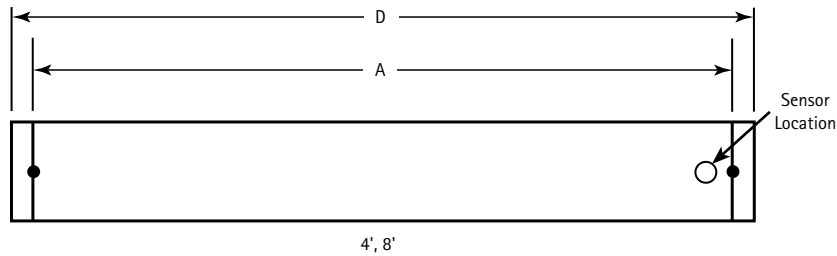

ROW MOUNTING

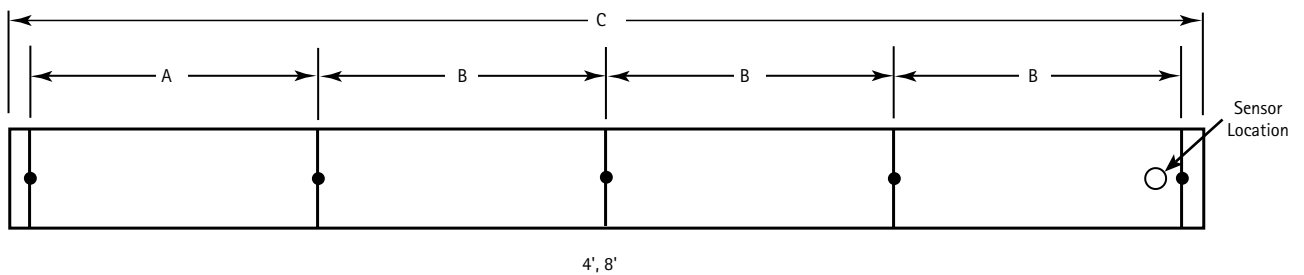

DATA CHART

Nominal Length	Approx. Weight			A	B	C	D
	1-lamp	2-lamp	3-lamp				
4'	13.1 lbs.	14.3 lbs.	14.7 lbs.	47 1/4"	48"	192 5/8"	48 5/8"
8'	25.1 lbs.	26.3 lbs.	26.7 lbs.	95 1/4"	96"	384 5/8"	96 5/8"

Note: Suspension data is computed using the standard aircraft cable assembly. The use of rigid stems will yield different data. Please consult factory for stem data.

Limitations exist for rows containing Installed Architectural Sensors; contact factory for assistance.

Connection Instructions:

1. Install first fixture of row with two hangers.
2. Slide inner die cast plates together.
3. Secure fixture joints with two bolts and nuts and attach hanger at opposite end.
4. Repeat steps 2 and 3 until row is complete.
5. At each end of the row, attach and align end cap with two screws.

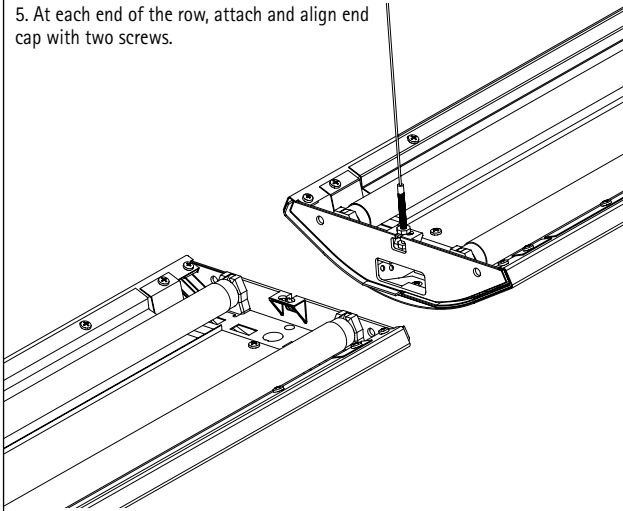

Suspension Instructions:

1. Set bottom nut to desired fixture height.
2. Adjust upper nut for a minimum of $\frac{3}{8}$ " between upper and lower nuts.
3. Slide cable hanger into hanger slot.
4. Secure and tighten upper nut.

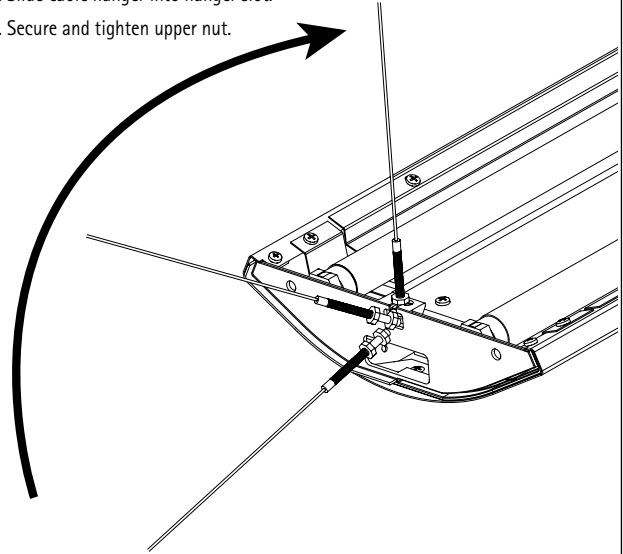

Cover Removal:

1. Rotate fasteners 90 degrees.
2. Lift and remove.

