

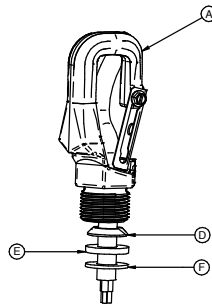

**INSTALLING HOOK/LOOP MOUNT (See Figures 1 and 2):**

NOTE: Items D, E and F are supplied with power cord – CxHLPx (Ordered separately)

1. Loosen the Pendant Cover (B) and Hub (C) as shown.  
IMPORTANT NOTE: This external thread on the Hub (C) is LEFT-HANDED. Turn clockwise to loosen. The Pendant Cover (B) and Hub (C) can remain together.
2. Slide the Pendant Cover (B) and Hub (C) along the keyhole slot in the driver housing until the Hub can be removed from the fixture.
3. Insert end of Power Cord through Hook (A). Supply cord is to be rated for a minimum of 90°C 16/3 SEOW-A.
4. Insert end of Power Cord through the Cord Grip/Gotcha-ring (D), Rubber Bushing (E) and Washer (F). Note that the Rubber Bushing is placed between the Cord Grip and Washer. Part of the cord jacket should extend through Bushing (E) and Washer (F).
5. Insert the Power Cord through the Hub (C) and allow the Washer (F), Bushing E) to "seat" inside of the Hub (C). The Cord Grip (D) remains in place at the Hook/Loop.



**FIGURE 1**

6. Apply Teflon tape to the male (external) conduit thread of the Hook (A) as well as the male (external) threads of the Hub (C).
7. Thread the Hook (A) into 3/4" NPS Hub (C) — this thread is RIGHT-HANDED thread. Use a wrench over the hex shape on the hook casting to tighten it in place.  
CAUTION: Do not twist the hook by using a screwdriver blade – too much force could break the hook.
8. Connect cord wires to the fixture wires with approved wire nuts. See wiring diagram for reference (page 3). Wires and wire nuts can now be pushed back into the fixture/driver housing.
9. Place Hub into top of driver housing so that the "flat surfaces" of the hub align with the keyhole slot.

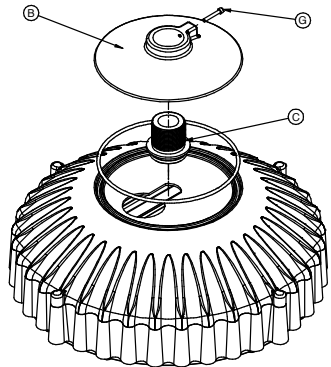
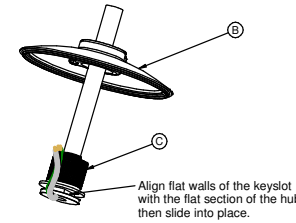

**FIGURE 2**

10. Slide the hub and top cover back to its original position (centered on the fixture).
11. Tighten the pendant cover/hub/hook by rotating the pendant cover counter-clockwise (the hub has LEFT-HANDED external thread).
12. Tighten Set Screw (G) to secure hook from loosening.
13. Remove protective film from lens if applicable.

**INSTALLING PENDANT MOUNT (See Figures 3 and 4):**

1. Loosen the Pendant Cover (B) and Hub (C) as shown.  
IMPORTANT NOTE: This external thread on the Hub (C) is LEFT-HANDED. Turn the Pendant Cover (B) clockwise to loosen. The Pendant Cover (B) and Hub (C) should be separated.
2. Slide the Hub (C) along the keyhole slot in the driver housing until the hub can be removed from the fixture.



**FIGURE 3**

3. Assemble the Pendant Cover (B) by sliding it onto the 3/4" or 1" conduit through the center hole. For ease of assembly, a clamp or vise-grips can be used to help hold the pendant top in place (place the clamp/vise-grips on the conduit below the cover and then let the cover rest on the clamp/vise-grips).
4. Apply Teflon tape to the male (external) conduit/pendant thread as well as the male (external) threads of the Hub (C).
5. Insert the supply wires from the conduit through the Hub (C) and thread the hub onto the 3/4" or 1" conduit.
6. Supply wires should be pulled up tight against the Hub (C) and temporarily taped to the outside of the Hub (C) (See Figure 3).
7. Note the orientation of the two "flat" surfaces on the Hub (C) and then lift the fixture to Hub (C), making sure that the keyhole slot in the driver housing is in alignment with the Hub (C) (See Figure 3).

8. Slide the fixture back to its original position (centered on the Hub (C)).
9. Connect supply wires to the fixture wires with approved wire nuts. See wiring diagram for reference (page 3). Wires and wire nuts can now be pushed back into the fixture/driver housing.
10. Remove clamp/vise-grips that are being used to hold the pendant cover out of the way and allow the pendant cover to drop to the threaded Hub (C).
11. Begin rotating the pendant cover counter-clockwise to "tighten" it on the threaded Hub (C). Once contact is made between the pendant cover and the driver housing/fixture, it may then become easier to turn the fixture itself (clockwise) to continue tightening and sealing the fixture.
12. Once completely assembled and sealed, tighten Set Screw (F) to secure pendant/conduit from loosening.
12. Remove protective film from lens if applicable.

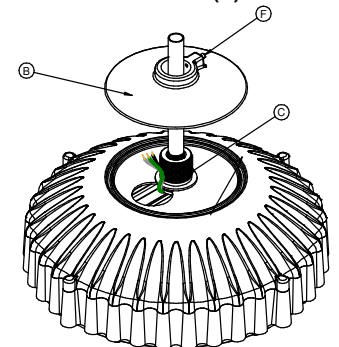

**FIGURE 4**