



WARNINGS

- This product contains chemicals known to the state of California to cause cancer, birth defects and/or other reproductive harm.
Thoroughly wash hands after installing, handling, cleaning, or otherwise touching this product.
- Contact Hubbell Lighting, Inc. for information and direction before relamping or replacing this light fixture.
 - Disconnect power before installing or servicing.
 - Install, operate and maintain to meet all applicable codes.
- Protect all wiring connections with approved insulators (by others).
 - Selected fixture voltage must match supply line voltage.

INSTALLATION INSTRUCTIONS

GENERAL INFORMATION, CONDUIT MOUNT:

- All 12" (304.8 mm) minimum supply wire outside of conduit.
- Fixture housing conduit threads are 3/4-14 NPS or 1-11 1/2 NPS.
- Use a waterproof pipe joint compound (by others) for all entries into housing.
- Plug all unused entries into housing (if applicable).

PENDANT/CONDUIT & CONE MOUNT: (See Figures 1a, 1b, 2, and 3)

1. To ease installation, top cover (1) should be removed from the fixture assembly. Unfasten the latch (2) and the top cover casting can be removed from the hinge pin assembly (3).
2. Feed electrical supply wire through one of (4) threaded hole in the cover and thread top cover onto conduit until tight.
3. Tighten set screw located on conduit hub inside the cover to prevent fixture rotation.
4. Fixture ground wire connection can be made with supply ground at this point if desired.
5. Lift fixture assembly and place the hinge pin (3) in the cradle (4) of the top cover casting. The fixture can now hang from the hinge pin.
6. Make remaining wiring connections. See appropriate WIRING SCHEMATIC for reference. If ground wire was not connected earlier, connect the fixture ground with the incoming ground wire. There will be a single white and a single black wire providing power to the entire array of LED drivers. Incoming power to be connected to the white wire and the black wire. See warnings above about wire connections.
7. Dress wires as needed.
8. Gently pivot the assembly up until the lower portion of the fixture is against the top cast cover. The lower portion of the fixture should "nest" inside the fixture cover (1). The sealing gasket (5) should compress evenly as well.
9. Swing barrel nut latch (6) over the top cover at the latching point (7).
10. Use Flathead Screwdriver or 1/4 in. driver to secure the housing to the cover. Draw the two halves of the fixture together by tightening the screw.

INSTALLATION INSTRUCTIONS

STRAIGHT STANCHION/POLE MOUNT: (See Figures 1c, 2, and 3)

1. To ease installation, top cover (1) should be removed from the fixture assembly. Unfasten the latch (2) and the top cover casting can be removed from the hinge pin assembly (3).
2. Feed electrical supply wire from the mounting pole through the wireway in the top cover and then thread/screw the top cover onto the mounting pole until tight (and in desired orientation).
3. Tighten set screw location on cast top to prevent fixture rotation.
4. Follow steps 4 through 10 from previous section of instructions.

INSTALLING PENDANT MOUNT (See Figures 3 and 4):

GENERAL INFORMATION, CONDUIT MOUNT:

- All 12" (304.8 mm) minimum supply wire outside of conduit.
- Fixture housing conduit threads are 3/4-14 NPS or 1-11 1/2 NPS.
- Use a waterproof pipe joint compound (by others) for all entries into housing.
- Plug all unused entries into housing (if applicable).

WALL MOUNT: (See Figures 1d, 2 and 3)

1. To ease installation, top cover (1) should be removed from the fixture assembly. Unfasten the barrel nut latch (2) and the top cover casting can be removed from the hinge pin (3).
2. Feed electrical supply wire through one of (4) threaded holes in the cover and thread top cover onto conduit until tight.
3. Attach top cover to wall using recommended hardware.
4. Fixture ground wire connection can be made with supply ground at this point if desired.
5. Lift fixture assembly and place the hinge pin (3) in the cradle (4) of the top cover casting. The fixture can now hang from the hinge pin.
6. Make remaining wiring connections. See appropriate WIRING SCHEMATIC for reference. If ground wire was not connected earlier, connect the fixture ground with the incoming ground wire. There will be a single white and a single black wire providing power to the entire array of LED drivers. Incoming power to be connected to the white wire and the black wire. See warnings above about wire bconnections.
7. Dress wires as needed.
8. Gently pivot the assembly up until the lower portion of the fixture is against the top ncast cover. The lower portion of the fixture should "nest" inside the fixture cover (1). The sealing gasket (5) should compress evenly as well.
9. Swing barrel nut latch (6) over the top cover at the latching point (7).
10. Use flathead screwdriver or 1/4 in. driver to secure the housing to the cover. Draw the two halves of the fixture together by tightening the screw.

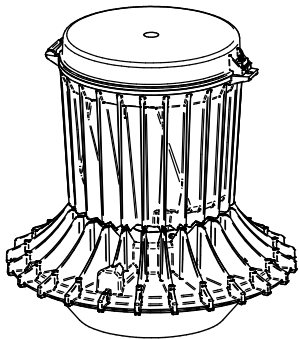

FIGURE 1a

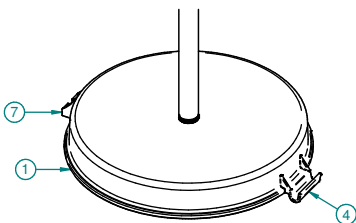

FIGURE 1b

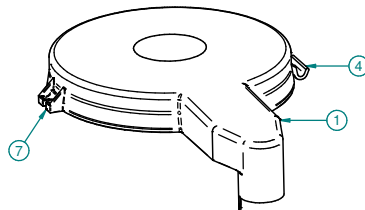

FIGURE 1c

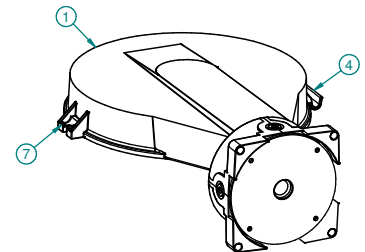

FIGURE 1d

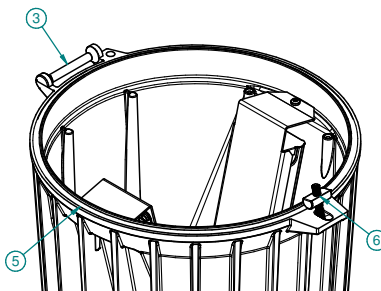

FIGURE 2

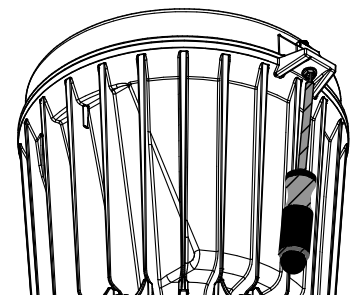
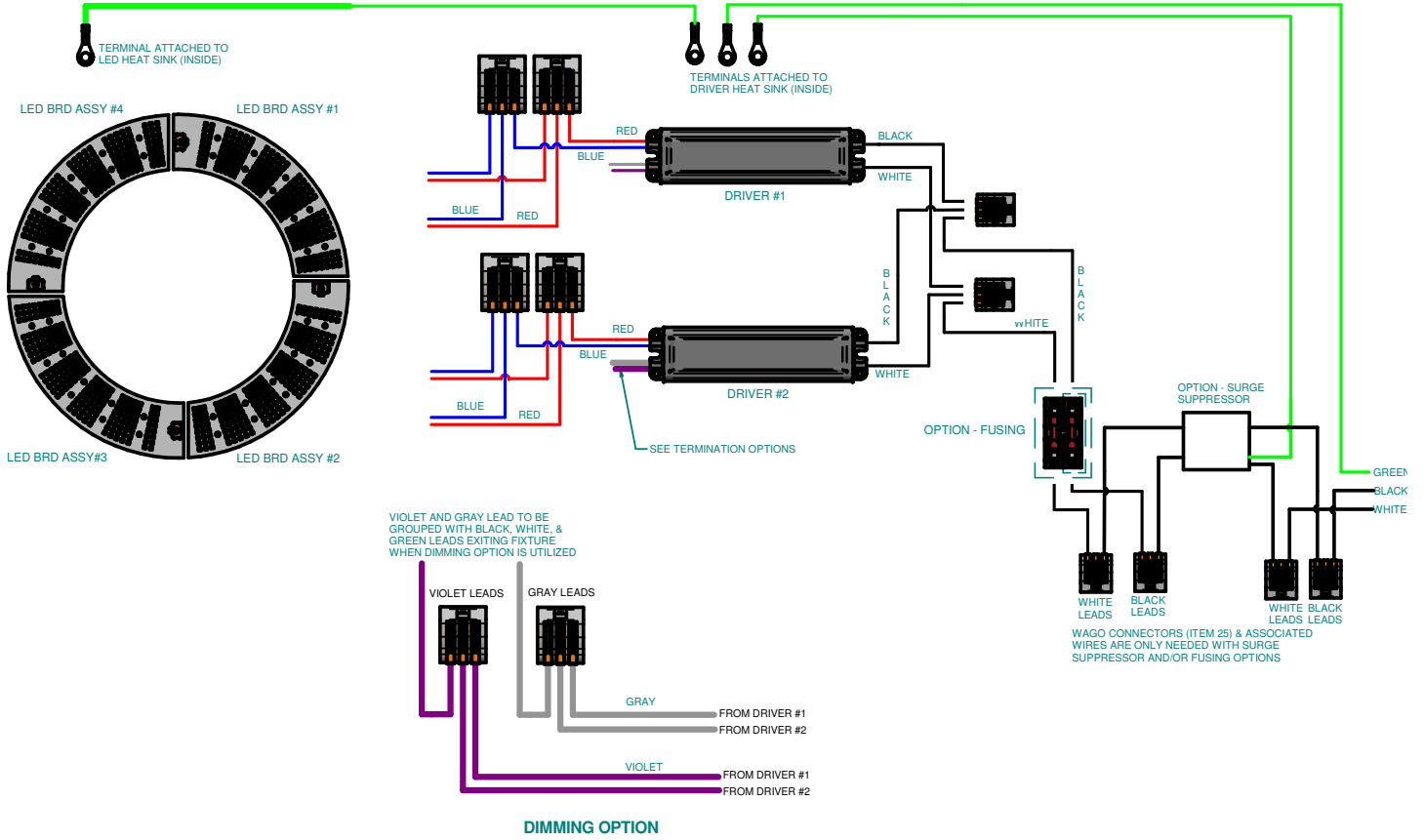

FIGURE 3

WIRING DIAGRAMS

ML AND MM DIAGRAM



LV DIAGRAM

