

UTILIBAY™ UTB2 HIGH BAY

HUBBELL®
Industrial Lighting



WARNINGS

 **WARNING:** This product can expose you to chemical including lead and lead compounds, which are known to the State of California to cause cancer and birth defects or other reproduction harm.

For more information go to www.P65Warning.ca.gov.

- Contact Hubbell Lighting, Inc. for information and direction before relamping or replacing this light fixture.
- Disconnect power before installing or servicing. Observe all precautions usually followed when dealing with high voltage equipment when installing or servicing this light fixture.
- The product must be installed in accordance with the applicable installation code by a person familiar with the construction and operation of the product and the hazards involved.
- Protect all wiring connections with approved insulators rated 600V / 150°C (by others.)
 - Selected fixture voltage must match supply line voltage.

SAVE THESE INSTRUCTIONS FOR FUTURE REFERENCE

- Upon receipt of this fixture, thoroughly inspect it for any damage. If any is found, the carrier should be notified and held accountable.



HUBBELL
Lighting

FIXTURE RECEIVING:

1. For shipping purposes, the fixture will come in multiple boxes.
2. The upper assembly will be packaged separately from the reflector assembly and the lens assembly.
3. See instructions on pages 3 & 4 for initial fixture assembly.

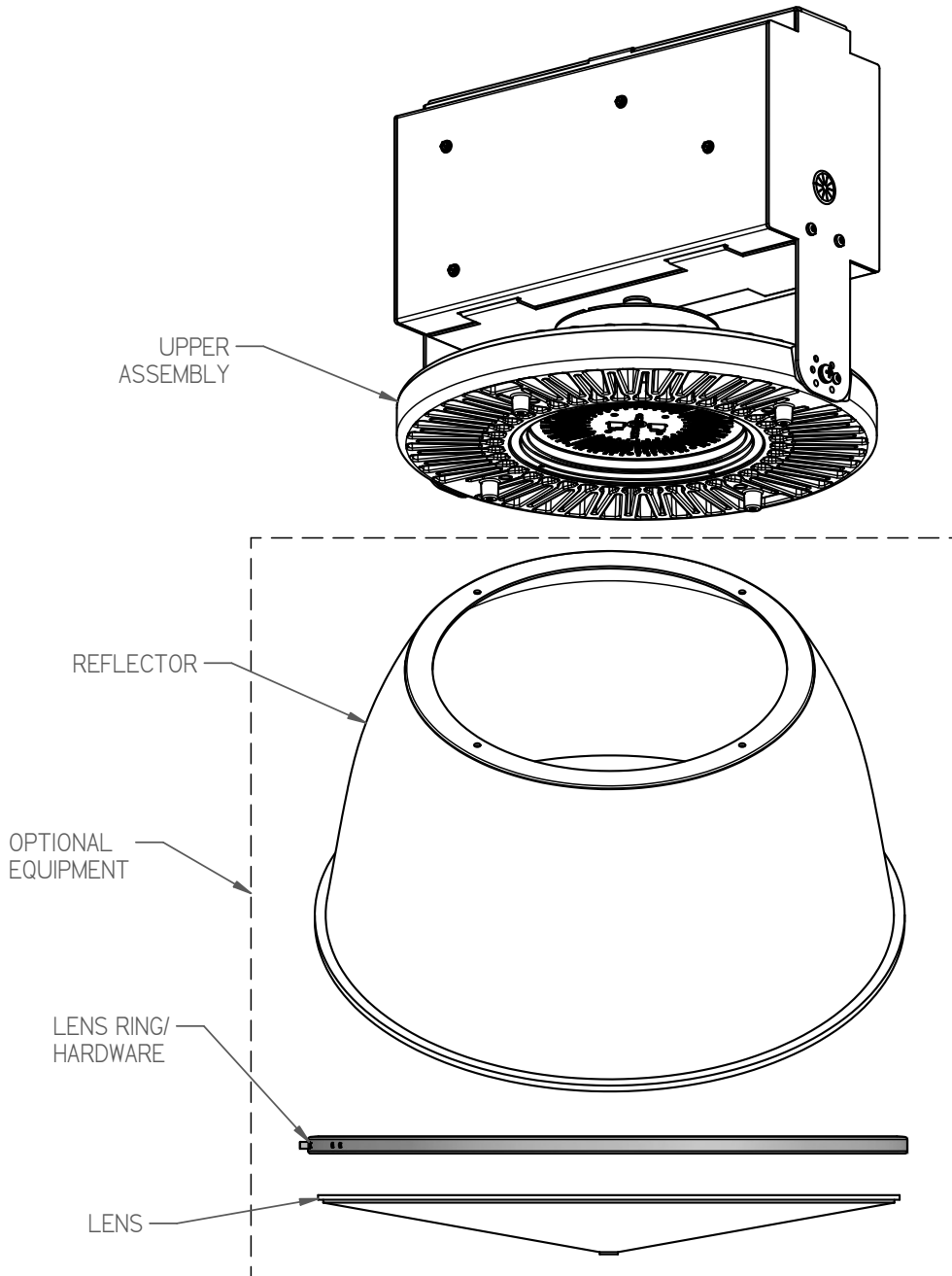

FIGURE 1
FIXTURE BOXING

INITIAL FIXTURE ASSEMBLY:

1. Align holes in Yoke to holes on side of heatsink (2 places). (See Figure 1)
2. Secure Yoke to heatsink with (2) ¼-20 screws and (2) star washers. (See Figure 2)
3. Route wiring into electrical box on heatsink and fasten electrical connections.
 - a) For LX/LXHE models, fasten the connector to its mating half. Connectors can only be assembled one way. (See Figure 3a)
 - b) For MM/MMHE/MH/MMHE models, fasten the two connectors to their mating half. Connectors can only be assembled one way. (See Figure 3b)
4. Place connectors inside electrical box and fasten the cover to the heatsink using (2) 8-32 screws. The wiring should route through the bushing in the cover. The Yoke will need to be rotated to each side to access the screw heads. (See Figure 1)
5. Fasten (2) 8 32 screws through the yoke and into the heatsink to lock the rotation of the heatsink. (See Figure 2)

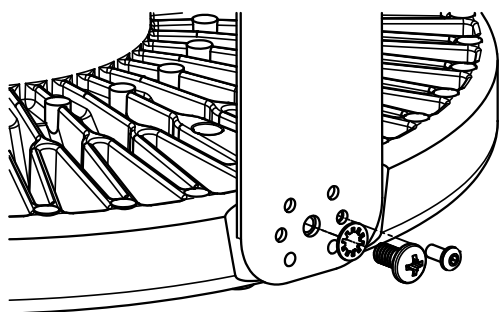

FIGURE 2
YOKE HARDWARE

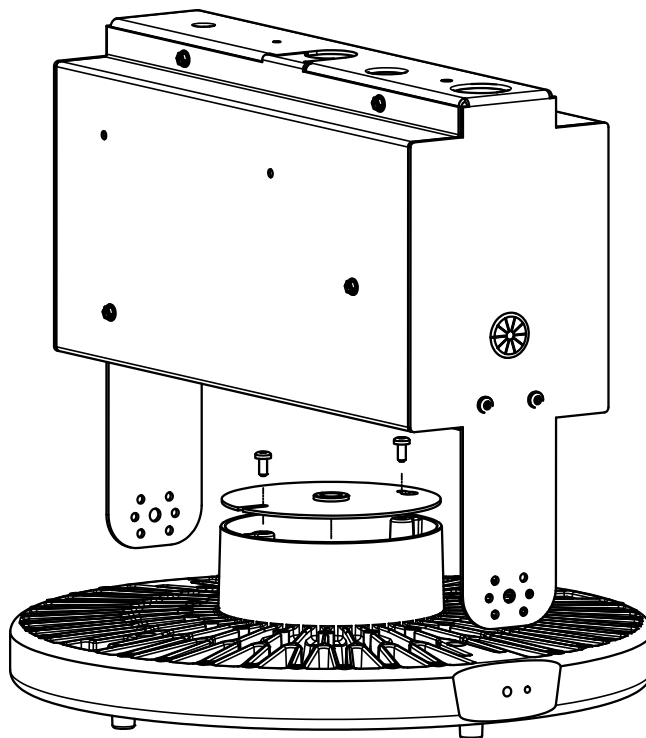

FIGURE 1
YOKE TO HEATSINK ASSEMBLY

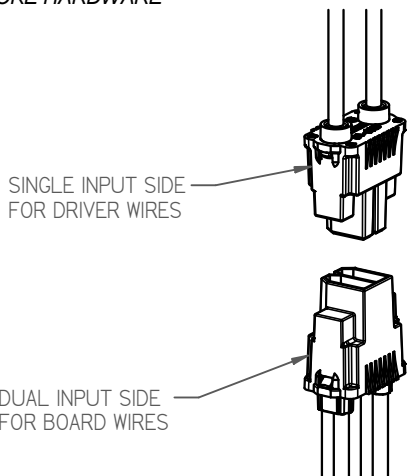

FIGURE 3a
LX / LXHE CONNECTOR

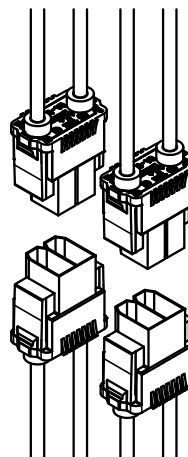
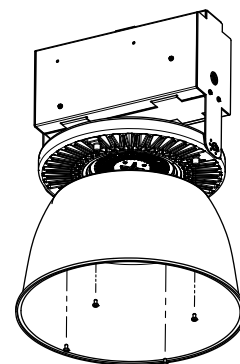

FIGURE 3b
MM / MMHE / MH / MMHE CONNECTORS

REFLECTOR INSTALLATION:
(See Figure 3A)

1. Reflector can be installed on the ground or while fixture is hanging. If installing on the ground, it is best to place fixture on its side.
2. Locate the four (4) threaded protrusions from the bottom of the heatsink and align them with the holes in the reflector.
3. Using the supplied hardware (#8 screws), fasten the reflector to the heatsink.



LENS INSTALLATION (If Optional):
(See Figure 3B)

1. Once the reflector has been mounted to the upper assembly, then the lens can be installed.
2. Seat the lens into the bottom of the reflector
3. Orient Lens Mounting Ring such that short leg of the cross section is on top and install over the lip of the reflector and lens. See Figure 3B.
4. While manually holding the ring together, install screw through bracket holes and thread on hexagonal nut and tighten till snug.

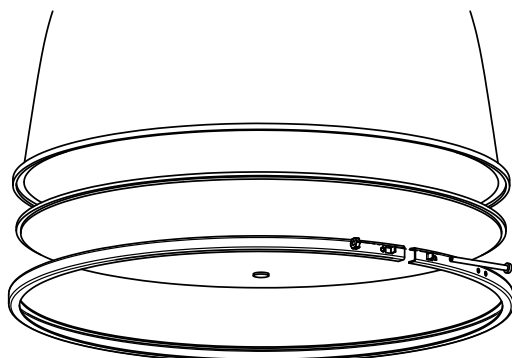

FIGURE 3B

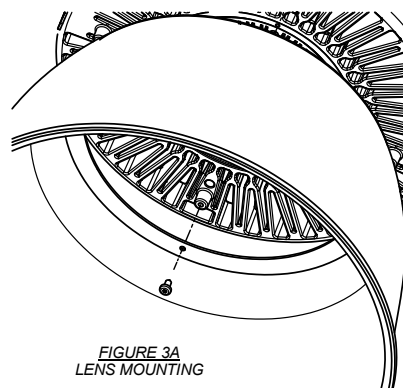

FIGURE 3A
LENS MOUNTING

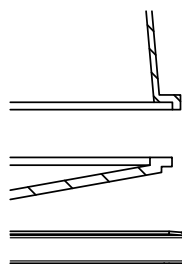

FIGURE 3B

GENERAL INFORMATION:

1. All 12" (304.8 mm) minimum supply wire outside of conduit.
2. Fixture mounting hook loop threads are 3/4-14 NPS.

HOOK/LOOP MOUNTING: (Figures 5A, 5B & 5C)
Cord & Hook/Loop ordered as CxHLPx (Plug optional)

1. If not already done, assemble the hook loop pieces according to the following steps.
2. Thread the upper locknut (with flat surface down) onto the hook loop to approximately 1/8" from the top of the threads. (Figure 5A)
3. Position the safety clasp as shown and just start the fastener, but leave loose. (Figure 5A)
4. Insert the power cord, must be rated minimum 90°C 16/3 SEOW-A or equivalent, through the hole in the hook and insert gotcha ring, top washer, gasket, lower washer and cast bushing/nut onto cord. Fully tighten cast bushing against bottom of hook. (Figure 5A)
5. Slide the assembly into the slot on the fixture yoke, so that the upper locknut is on top and the tightened cast bushing is on the bottom and hand tighten the upper locknut. (Figure 5B)

6. After the wiring is connected on the inside of the fixture, close the housing door such that the tab on the cover fits under the top exposed locknut on the hook loop. (Figure 5C)
7. Once fixture is fastened closed, tighten the upper locknut with a pair of pliers.
CAUTION: DO NOT TIGHTEN THE HOOK BY USING A SCREWDRIVER BLADE; TOO MUCH FORCE COULD BREAK THE HOOK. (Figure 5C)

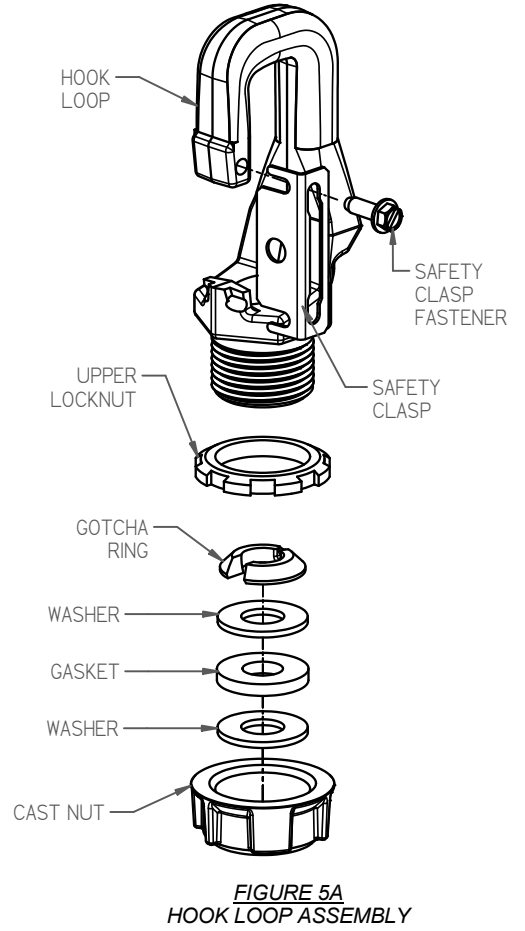
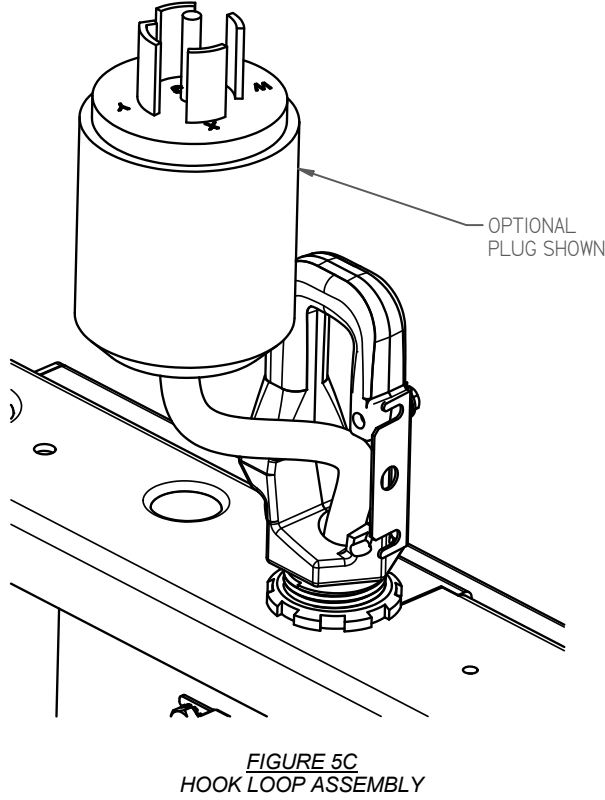
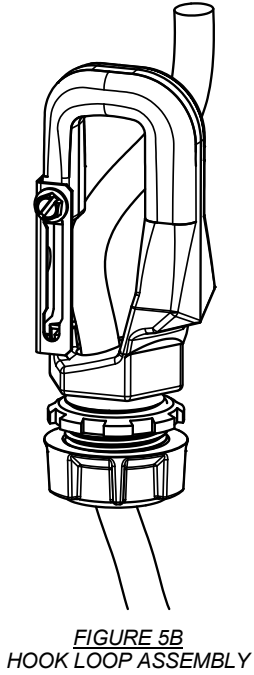

OPTICS WIRE GUARD INSTALLATION (If Optioned):

1. With mounting screws removed from heatsink, install full wire guard (WG-16) onto Reflector.
2. Install Reflector onto fixture heatsink using screws (4x) provided.

LENS WIRE GUARD INSTALLATION (If Optioned):

1. With the screws removed, spread the guard apart slightly and fit it around the lens ring already attached to the reflector.
2. The guard should mount around the lens ring such that the ring fits between the top two circular rings.
3. Insert the screws (2x) through the mounting holes and thread on the hexagonal kepis nuts (2x). Tighten the nuts till the guard is clamped around the lens ring.

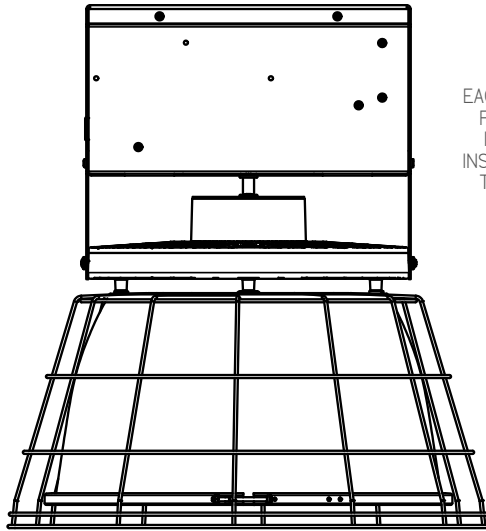
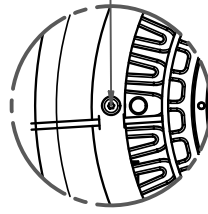
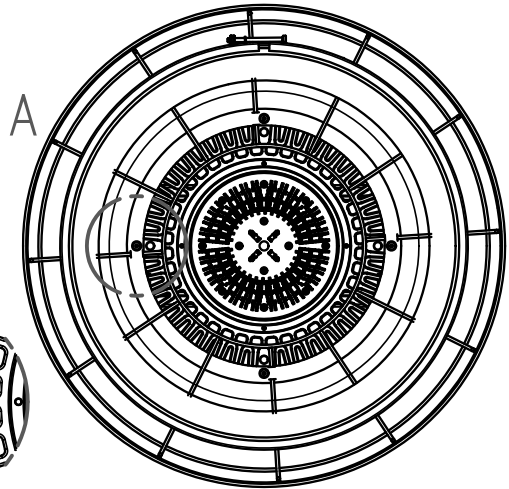

FIGURE 6A
FULL WIRE GUARD ASSEMBLY WG-16

EACH MOUNTING SCREW
FASTENS THRU OPTIC
INTO WG-16 CLIPS TO
INSTALL INTO HEATSINK
THREADED HOLES (4x)



DETAIL A



BOTTOM VIEW OF WG-16

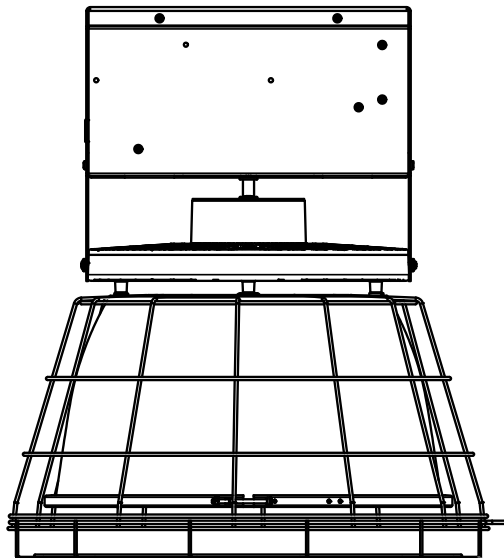

FIGURE 6B
FULL WIRE GUARD ASSEMBLY
w/**SHALLOW** LENS GUARD (WG-16S)

FOR DLR &
CDL LENS
OPTIONS

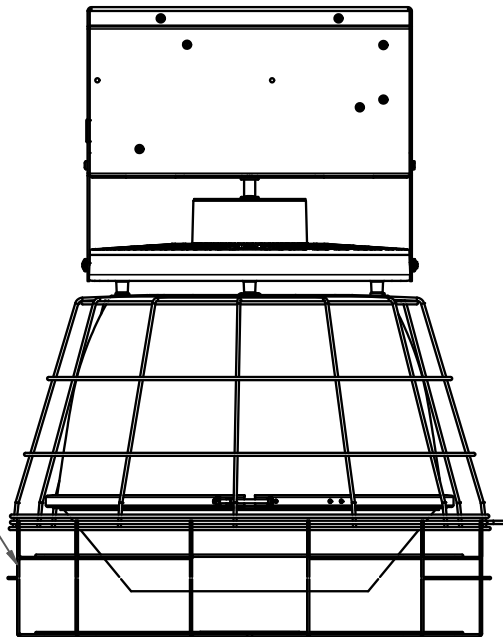

FIGURE 6B
FULL WIRE GUARD ASSEMBLY
w/**DEEP** LENS GUARD (WG-16D)

FOR P95 &
NO LENS
OPTIONS

OCCUPANCY SENSOR INSTALLATION (If Optional):

NOTE: If a wireguard is supplied, the wire guard needs to be installed first (see Page 9, Fig. 7A) before installing sensor on the bracket. Position the guard so the sensor bracket fits through the top two rings of the guard.

1. Position the sensor box (without the tightening ring attached) on top of the bracket and place the threaded shaft through the hole in the bracket. Fasten the tightening ring onto the threads until sensor box is secure. See Fig. 7B
2. Screw the sensor lens onto the threaded shaft until secure. See Fig. 7C.

*FIGURE 7A
WIRE GUARD ASSEMBLY
W/ OCCUPANCY SENSOR
OPTION SCL/SCD*

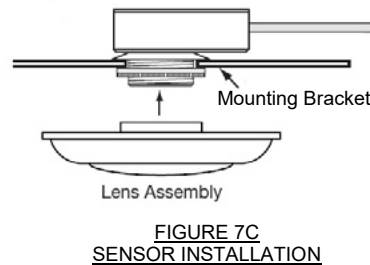
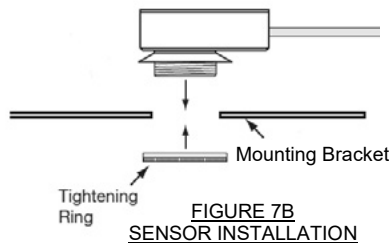
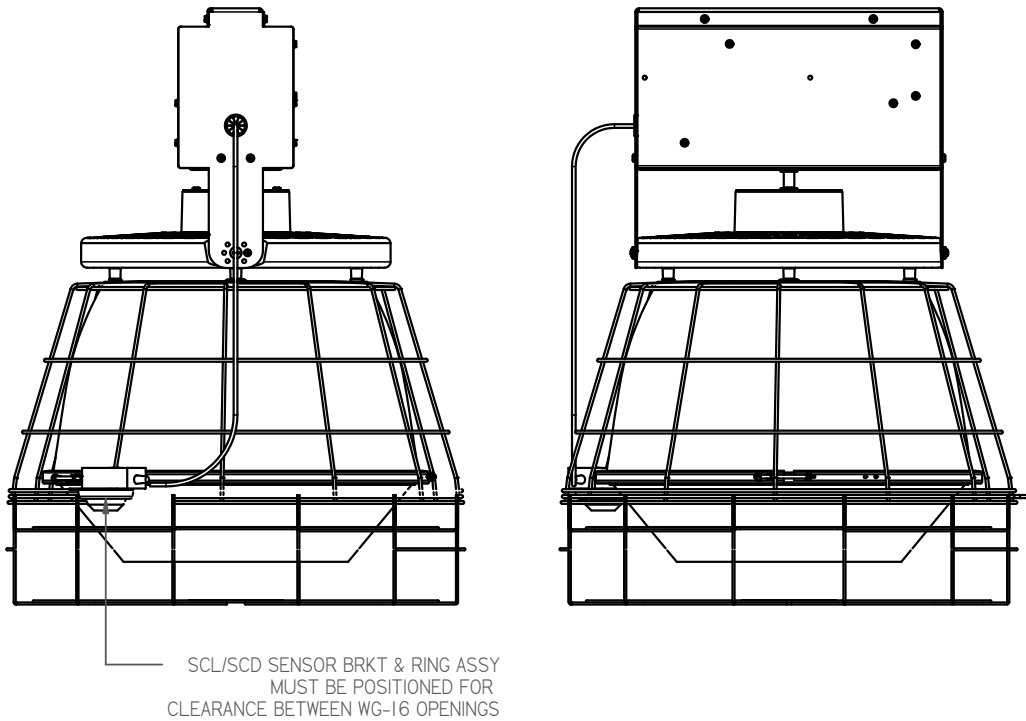

**For additional information on UTB, please visit our website:
<https://www.hubbell.com/hubbellindustrialighting/en>**