

EV Grade, For Fast, Safe, Efficient Performance



Exceeding industry standards

Our EV grade devices are designed specifically for safe, continuous, hours-long operation during charging. They are recommended for all electric vehicles and specified by manufacturers in the market.

- Fully tested for continuous use
- 30A and 50A, 125/250V, 3 pole, 4 wire grounding
- NEMA 14-50, the most popular type for EVSE
- Provides up to 13 miles more driving range per hour of charge than 30A receptacles
- Molded-in catalog number, ratings, certificates on the face
- Single-piece contacts reduce the risk of overheating
- UL Listed, CSA Certified
- NEMA WD-6 compliant

Quality Bryant plugs and receptacles deliver performance, quality, and reliability - perfect for DOE Zero Energy Ready homes and all homes that value safety.



ORDERING INFORMATION

Receptacles				
Description	Rating	Poles/Wires	Configuration	Catalog Number
Receptacle, black RTP	30A 125/250V	3P/4W	14-30R	9430FR
	50A 125/250V	3P/4W	14-50R	9450FR
	50A 250V	2P/3W	6-50R	9650FR

Plugs	
Description	Catalog Number
Plug, nylon, angle, 4-position	9432ANPB
	9452ANPB
	9650ANPB

Electric Vehicle Charger Receptacle

Product Dimensions

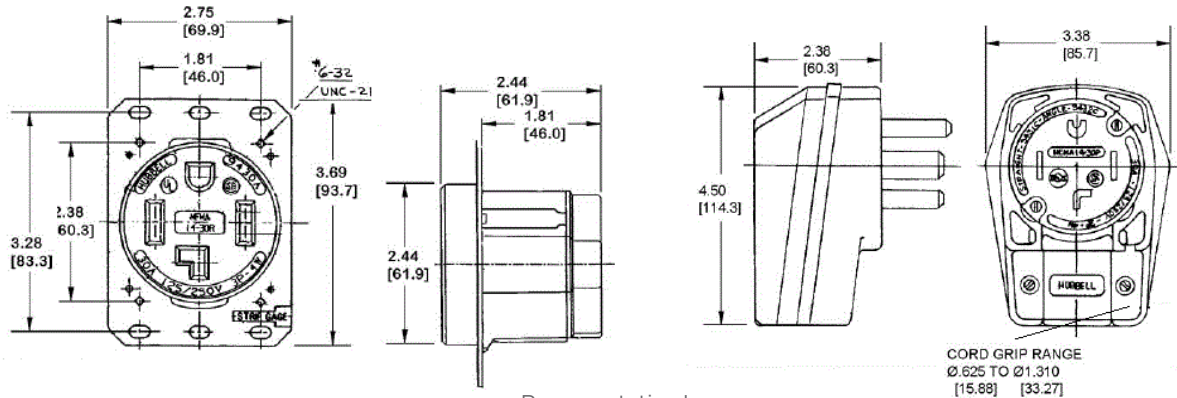

Representative Images

Technical Information

Performance

ELECTRICAL

Current Interrupting	Certified for current interrupting at full rated current
Dielectric Voltage	Withstands 2,000V minimum

MECHANICAL

Product Identification	Ratings are a permanent part of the device
Terminal Accommodation	#12 AWG through #4 AWG copper wire only
Terminal Identification	Terminals identified in accordance with UL 498 and CSA

ENVIRONMENTAL

Flammability	UL 94 V-0
IP Suitability	IP20
Operating Temperatures	Maximum continuous 75°C; minimum -40°C (w/o impact)

Specifications

Housing	Reinforced Thermoplastic Polyester
Mounting Plate	.062 in. (1.5) Pre-Plated Steel
Contacts	Brass
Ground Shunt	Brass
Box Terminals	Copper

Listings

UL Listed File E2186
CSA Certified
NEMA® WD-6 Compliant

Contact your local Bryant representative today to find out more or request a sample



A Hubbell brand

©2024 Hubbell Incorporated. All rights reserved.
Bryant and the Bryant logo are registered trademarks or trademarks of Hubbell Incorporated.

All other trademarks are the property of their respective owners.
hubbell.com/bryant | 40 Waterview Drive, Shelton, CT 06484 | 800-323-2792

EP-BRY-SF-EN-01870 | REV 06/24 06/24