

# QUADCAB® HQC Series Wall-Mount Cabinets

## Built to Last, for Light to Heavy-Duty Use

The QUADCAB® HQC series of wall-mount, swing-out cabinets are built with solid Hubbell quality and the innovations users need most. All the essential features of the Light Duty (HLQ) and Super Duty (HSQ) cabinet series have been brought to the HQC line to create exceptional value.

HQC cabinets are easy to install and have a 300 lb. load capacity for all-purpose use.

### Features

- Adjustable depth mounting rails with threaded #12-24 holes
- 300 lb. load capacity for multiple device installation
- Reversible cabinet, for left- or right-hand door swing
- Fan knockouts, for easy installation of optional fans
- Rectangular knockout, to retrofit pre-installed cable
- Installed grounding jumpers to bond all cabinet sections
- Smoked plexiglass door standard
- Front door and center sections keyed alike
- Rear panel mounting holes spaced for 16" on center studs
- Accommodates new FCR-X rack-mount fiber enclosure
- Base panel with "belt loops", to mount an assortment of Hubbell bracket kits

### Applications

- Commercial
- General use
- Big Box retail space
- Extra protection in the telecom room



# Ordering Information

## HQC Quadcab® Series

Includes:

cabinet, (1) pair 19" mounting rails, (2) CH751 locks and keys, installed bonding conductors, powder-coated, black

Product Number	Description	Color	Rack Positions	Height "A" (in.)	Depth "B" (in.)	Overall Height Dim "C"	Dim "D"	Dim "E"
HQC2424	HQC, 24H x 24D, tinted plexiglass door	Black	12	24.12	24.33	25.12	17.77	N/A
HQC3624	HQC, 36H x 24D, tinted plexiglass door	Black	19	36.37	24.33	37.37	29.52	N/A
HQC4824	HQC, 48H x 24D, tinted plexiglass door	Black	26	48.62	24.33	49.62	41.77	19.20
HQC2432	HQC, 24H x 32D, tinted plexiglass door	Black	12	24.12	32.33	25.12	17.77	N/A
HQC3632	HQC, 36H x 32D, tinted plexiglass door	Black	19	36.37	32.33	37.37	29.52	N/A
HQC4832	HQC, 48H x 32D, tinted plexiglass door	Black	26	48.62	32.33	49.62	41.77	19.20

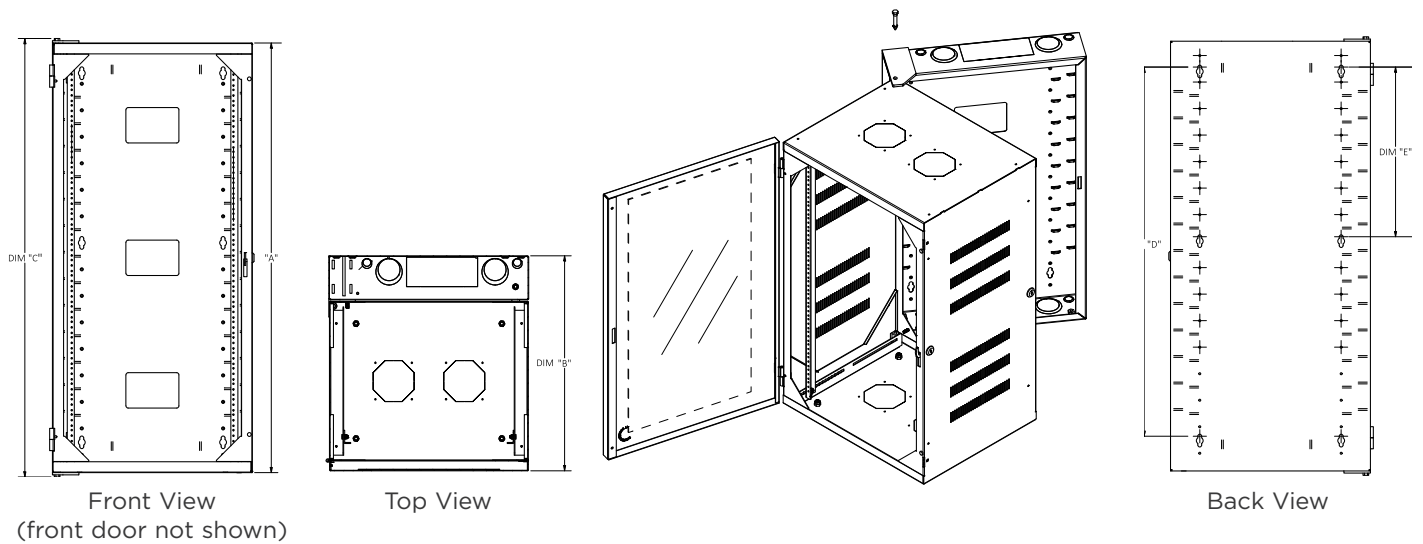

## SPECIFICATIONS

- UL 2416 listed
- EIA-310-E compliant
- Grounding provisions per TIA-607

## Accessories

Product Number	Description
HQCK	HQC Caster Kit with 5 stem wheels and nuts
HQCFK	HQC Fan Kit, one (1), 75 CFM Fan, hardware
HQCF	HQC Fan Filter Kit w/Filter Housing, Fan Guard, Filter
HQCFR5	HQC Fan Filter Replacement Kit (5 filters/pk)
REKP	20 Amp AC Power Kit w/Receptacle, Box, Flexible Conduit
REKGB	Grounding Kit with Busbar and Jumpers
REKFP	Fiber Optic Bracket for one FSP or Cassette

Product Number	Description
HWK6M6	Rear Rail Kit with two rails, 24" x M6
HWK9M6	Rear Rail Kit with two rails, 36" x M6
HWK12M6	Rear Rail Kit with two rails, 48" x M6
HWK241224	Rear Rail Kit with two rails, 24" x #12-24
HWK361224	Rear Rail Kit with two rails, 36" x #12-24
HWK481224	Rear Rail Kit with two rails, 48" x #12-24



A proud member of the Hubbell family.

©2024 Hubbell Premise Wiring. All rights reserved.

Hubbell and the Hubbell logo are registered trademarks or trademarks of Hubbell Incorporated. All other trademarks are the property of their respective owners.

23 Clara Drive, Suite 103, Mystic, CT 06355

[www.hubbell.com/hubbellpremisewiring](http://www.hubbell.com/hubbellpremisewiring) | 800-626-0005