

Line Extender

LE300

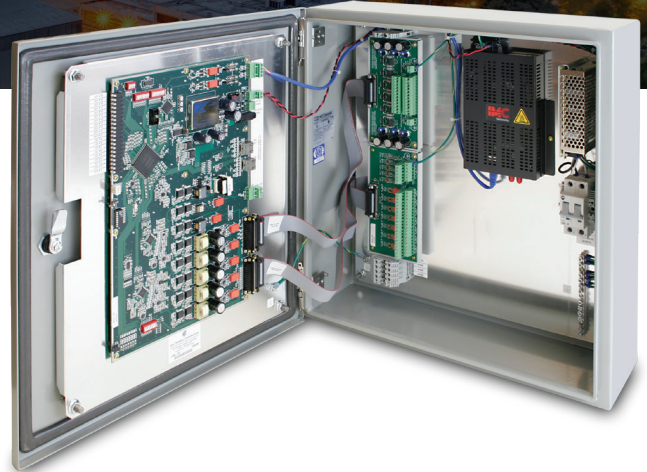

The Model LE300 is used in pairs to provide a transparent extension or expansion of a conventional Page/Party® or SmartSeries™ single or multi-party system. It can extend the system by linking two Page/Party® system cables located in areas separated by an appreciable distance. It can expand the system by allowing additional field devices to be connected with minimal loading to the page and party lines.

Each unit interfaces to one page line and up to five party lines, and provides connections for a page line audio detector output, a page line ground-fault detector output, a page line monitor output, five external auxiliary inputs, and five corresponding auxiliary contact closure outputs. There is no continuity (no dc path) between the system cables attached to the Model LE300s on the opposite ends of a data link, so the Model LE300 must convey all audio signals, line conditions, and other device states across the data link in digital form.

The Model LE300 uses T1 or E1 carrier technology to digitize the audio signals present on its system cable and time-division multiplex (combine) them with additional data such as the state of its auxiliary inputs. The Model LE300 transmits this 1.544 Mbps (T1) or 2.048 Mbps (E1) time-division multiplexed data stream over a full-duplex, point-to-point data link to its companion unit.

In general, when a Model LE300 detects a condition on its associated system cable, it causes that same condition to appear on the corresponding system cable attached to its companion unit.

For example, if it detects an off-hook condition on a party line, it causes the companion unit to simulate an off-hook condition at its corresponding party line interface. An auxiliary input controls only the corresponding auxiliary output on the companion unit. It does not affect any auxiliary outputs on the same unit.

Features

- For Use with Page Party® and SmartSeries™ Systems
- Either Copper or Fiber Transmission Medium
- Digital Transmission of Page Line and 5 Party Lines and Data
- Transmission Up To 25 miles over Fiber Optics
- T1 or E1 Technology Supported
- Page Line Monitor
- Audio Detector
- Ground-Fault Detector
- 5 External Auxiliary Outputs

System Extension Application

When used to extend the system, two Model LE300s can be separated by as much as 6,000 feet (approximately 1.8 km) using two pairs of 22-AWG unshielded twisted-pair (UTP) copper wire, category 5 or higher, as shown in Figure 1. (To do this without the Model LE300 would require a 16-conductor system cable and additional cable for other functions.) The Model LE300 can be separated up to 25 miles by installing the fiber optic option, which includes a fiber optic modem at each end linked by customersupplied optical fiber cable. The fiber optic option is also useful in environments where electrical interference (such as EMI, RFI, spikes, and differential ground loops) is a problem or where security is critical.

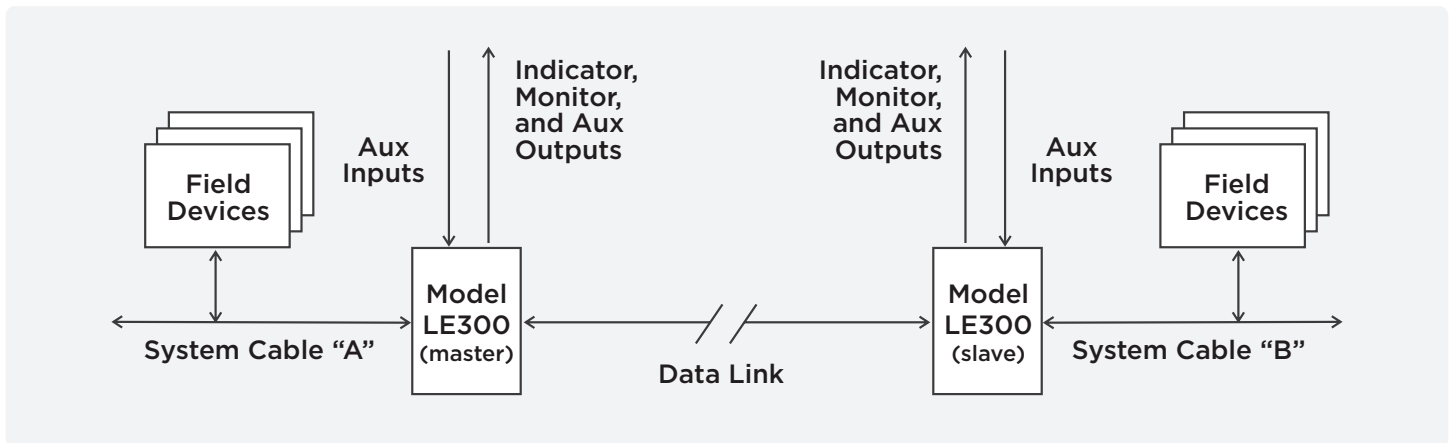

Figure 1 System Extension Application

System Expansion Application

When used to expand the system, two Model LE300s are co-located and interconnected by a short length of cable, as shown in Figure 2. The primary benefit from this application is that many field devices can be added without loading the system cable: The only additional device attached to the existing system cable is one Model LE300, with the field devices attached to the system cable on its companion unit.

Models	Description
LE300	For use with 22 AWG copper up to 6,000 Ft. distance
LE300-MM1	Multimode Fiber Optic Modem; up to 3 miles (5km) distance ¹
LE300-SM1	Singlemode Fiber Optic Modem Package; up to 37 miles (60km) distance ²
LE200-RM	Rack Mount Line Extender

¹Distance based on 12dB power budget.

²Distance based on 19dB power budget.

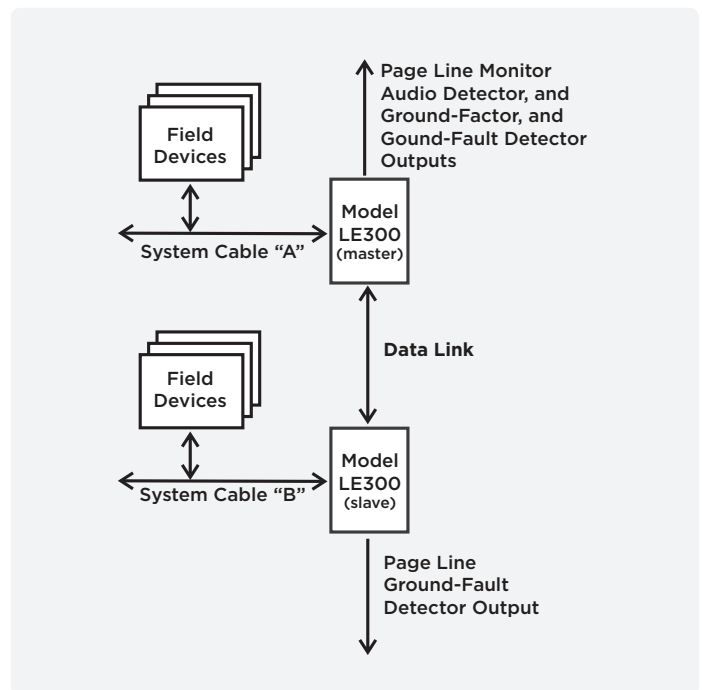

Figure 2 System Expansion Application



A proud member of the Hubbell family.