

FIBERGLASS CUTOUT & ARRESTER BRACKET

NEW PRODUCT FOR FIBERGLASS CONSTRUCTION

Fiberglass brackets are lighter weight and stronger alternative to wood brackets. They also have a longer life as they are not prone to environmental rotting, cracking and damage from insects and birds.

FEATURES AND BENEFITS

- Foam filled, nonconductive composite member
- UV inhibited Fiberglass coated with UV inhibitor
- Fire resistant relative to wood
- Aluminum mounting bracket with galvanized steel hardware

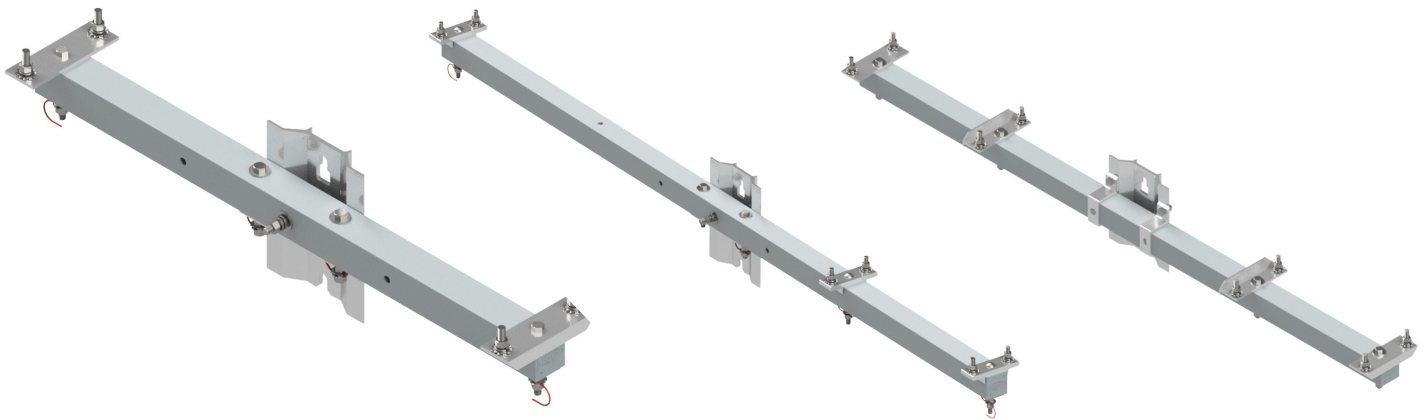

Consult factory for alternative lengths, hardware and optional bond wire.

Catalog Number	Length	Tube OD
CW4CA726FG	74"	2.65" X 2.65"
CW2CA44FQGFG	44"	2.65" X 2.65"
CW3CA92DNHFG	92"	2.65" X 2.65"
CW3CA92FG	92"	2.65" X 2.65"



hubbellpowersystems.com

For product inquiries, please contact your local sales representative or customer service representative.

©2020 Hubbell Incorporated.
Because Hubbell has a policy of continuous product improvement, we reserve the right to change design and specifications without notice.
Printed in the U.S.A. | SF_06_142E