

# ON THE SWITCH MOTOR OPERATED AR

OUR NEW AUTOMATED AIR BREAK SWITCH OFFERING FOR YOUR  
DISTRIBUTION AUTOMATION NEEDS

## INTRODUCTION

We are pleased to announce the release of our OTS (On The Switch) automated gang switch. Our AR switch is now offered with an optional integrated motor operator attached right to the crossarm. This helps to significantly reduce installation time and pole footprint for a SCADA ready GOAB.

## FEATURES AND BENEFITS

- Consistent optimal operation speed, eliminating the human element in operation
- Visible break clearly indicating when a section of the line has been sectionalized for safe down stream work
- FlexMo operator now supports DNP3 for remote open/close capability
- Optional Sensor and RTU add-ons for enhanced grid visibility and sectionalizing to also improve grid reliability

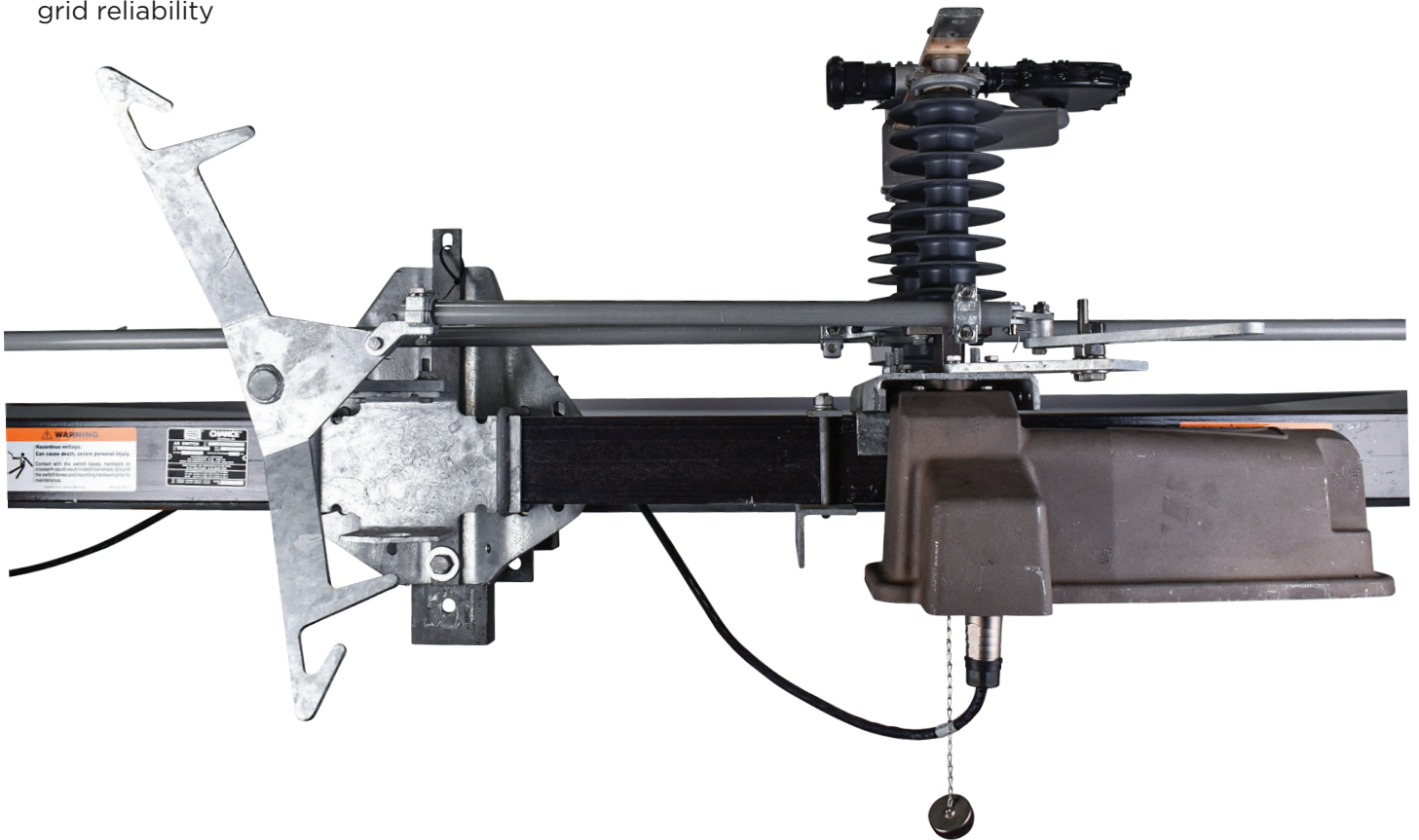
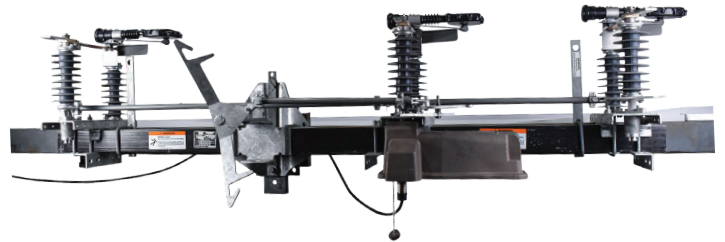

[hubbelpowersystems.com](http://hubbelpowersystems.com)

For product inquiries, please contact your local sales representative or customer service representative.

©2021 Hubbell Incorporated.  
Because Hubbell has a policy of continuous product improvement,  
we reserve the right to change design and specifications without notice.  
Printed in the U.S.A. | SF10319E