

# VR HELP POINT

Hands-free, Vandal Resistant



- SMART Analogue and VoIP-SIP options available
- Vandal Resistant Metal Buttons
- Hands-free operation
- Robust and weather resistant: Up to IP65
- One, two or three button autodial options with remote programming
- Dual purpose design for flush or surface mounting, simple installation
- Optional Induction Loop facility for hearing impaired<sup>1</sup>
- Line powered down to 25mA (Analogue models)<sup>1</sup>
- Optional mains supply adapter
- Non-volatile memory store
- Audio-visual ring indication
- CE Compliant

The VR Help Point family of telephones is fully electronic, vandal and weather resistant. It provides hands-free loudspeaking communications for any public area.

Incoming calls are indicated by a flashing LED and audible warble tone.

Connectivity Options Area:

### SMART Analogue

The standard analogue unit provides basic telephone functions and can be connected to any standard two-wire telephone line, including FXS ports, analogue PABX lines and PSTN.

Self Monitoring And Reporting Telephone can be integrated with GAI-TRONICS' TMA monitoring and maintenance software. SMART gives advanced features including remote programming, fault monitoring and call logging, all from a line-powered telephone capable of operating up to 7km from the exchange on a two-wire cable.

### Voice over IP (SIP protocol)

GAI-TRONICS VoIP-SIP telephones support Power over Ethernet (PoE) to combine power and connection

to LAN or WAN. GAI-TRONICS VoIP-SIP phones offer a wealth of additional features including real-time reporting via SNMP, and can be configured by web browser.

### Pushbutton Options

Units are available as multi or single button autodiallers providing on/dial/off functions

#### 1, 2, & 3 Button Autodiallers

These models are programmable with numbers up to 24 digits. A microphone muting facility guards against unauthorised calls made with a portable MF tone pad.



#### CB Telephone (with memory):

This can be used as a 'hotline' or press 'ON' and wait for reply.



<sup>1</sup> On the Analogue version, the induction loop requires additional 12 V dc power supply (included). On the VoIP version, the induction loop requires no additional power.

# VR HELP POINT TECHNICAL SPECIFICATIONS

## GENERAL SPECIFICATIONS

**Casing Material:** Front face plate mounting: aluminium sheet, polyester powder coat finish – Colour: silver grey – call for other options. Rear enclosure (if required)

**Push Buttons:** Metal, vandal resistant

**Temperatures:** Operating: -40° C to +60° C  
Storing: -40° C to +70° C

**Weather Resistance:** up to IP65 dependent on installation  
Please call for advice on application.

**Weight:** 2kg  
With backbox (sold as separate item) total weight is 4kg

## ANALOGUE

**Speech:** Voice-switched (VOX) semi-duplex operation.  
Call timeout programmable from 1 to 42 minutes  
Remote switch-off capability

**Dialling:** Autodial keypad single-press switch-on-and-dial  
24 digits maximum with embedded Recall, Pause, Pulse & Tone characters

**Ringing:** Dual tone ringing through loudspeaker >75 dB @ 1m  
REN 1

**Power Supply:** Line powered only operation down to 25mA.  
Supplementary power 12 V dc 250mA. Below 35mA line current supplementary power is recommended to achieve full volume.

**Lightning / Transients:** Protection to ITU-T k.21 enhanced levels

**Memory Retention (autodiallers):** E2 Prom - 10 year life

### OPTIONS

**Remote Programming:** Auto-dial numbers, time-out and dial mode can be programmed over the phone line either from a tone phone or from monitoring software (TMA)

**Configuration:** Remotely programmable via TMA

**Remote Monitoring:** Remote health-check and fault reporting, either on a call-in or polled basis. TMA required.

**Call Logging:** Records call time, duration and auto-dial number used. TMA required.

## VOICE over IP - SIP

**Speech:** Full duplex, 6 codecs available inc G.711 + G.722

**Power Supply:** External 24-48 V dc or Power-Over-Ethernet (PoE 802.3af compliant)  
Power requirement 7W max (4W idle)

**Call Set-up Protocol:** Session Initiation Protocol (SIP) (RFC 3261) only

**Configuration:** Via configuration file or web page.  
Static IP address provisioning or DHCP

**External I/O:** 4 auxiliary inputs, 2 isolated relay outputs (1 capable of switching 230 V dc)

**Monitoring & Reporting:** Real-time via SNMP

**Audio Path Testing:** Allows remote testing of microphones and speakers, to verify that a phone is functioning acoustically. Can be run on demand or on a scheduled basis, reporting its results via SNMP.

## DIMENSIONS (Flush Mounting)

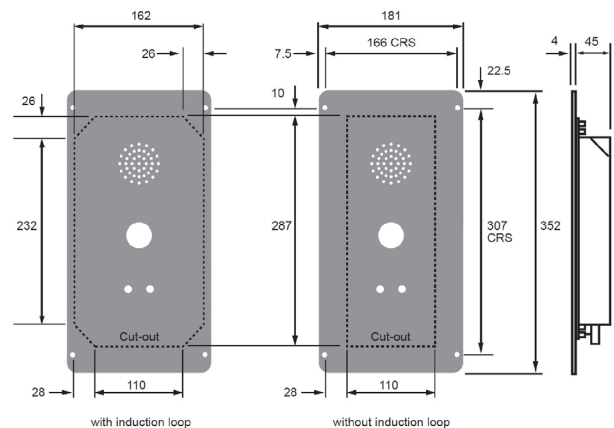

## APPROVALS



2011/65/EC- RoHS 2 Directive



This mark indicates compliance for inductively coupling to Hearing Aids having a 'T' switch position  
Optional Induction Loop for hearing impaired  
Tested to CTR21



Empowered by Innovation

For specific country approval, please call

## OPTIONAL ACCESSORIES

Please ask for Brochure B150 or visit [www.gai-tronics.co.uk](http://www.gai-tronics.co.uk)

## ORDER INFORMATION

T: +44 (0) 1283 500500 E: [sales@gai-tronics.co.uk](mailto:sales@gai-tronics.co.uk)

Item Description	Part Number
VR 1 Button Analogue Faceplate	228-02-2001-901
VR 2 Button Analogue Faceplate	228-02-2002-901
VR 3 Button Analogue Faceplate	228-02-2003-901
VR 1 Button VoIP-SIP Faceplate	116-02-0011-001
VR 2 Button VoIP-SIP Faceplate	116-02-0012-001
VR 3 Button VoIP-SIP Faceplate	116-02-0013-001
Rear Enclosure Box (GREY)	100-02-0257-003

As well as the standard Help Point range, GAI-TRONICS can supply specials to order with customised options.



UK: Tel: +44 (0) 1283 500500  
USA: Tel: +1 (610) 777-1374  
Italy: Tel: +39 02 4860 1460  
Asia: Tel: +60-3-8945-4035  
Australia: Tel: +61-28-851-5000

[www.gai-tronics.co.uk](http://www.gai-tronics.co.uk)  
[www.gai-tronics.com](http://www.gai-tronics.com)  
[www.gai-tronics.com](http://www.gai-tronics.com)  
[www.gai-tronics.com](http://www.gai-tronics.com)  
[www.austdac.com.au](http://www.austdac.com.au)

