



UL Listed for Countertop Installation

Hubbell Pop-Up Receptacles for countertops provide a power source ideal for kitchen and bath counters and islands. Hubbell is the first to market a countertop receptacle that is UL Listed. It allows compliance with NEC® 406.5(E) [countertops], 406.5(F) [work surfaces], and 406.5(H) [seating areas]. Pop-Up Receptacles are tested and water resistant to a half gallon spill. The receptacles feature Hubbell's patent pending silicone gaskets and patented cam action tamper-resistant technology. The compact design minimizes space required on the countertop as well as underneath in the cabinet area.

Features

- Surface or flush mount options
- Permanent installation ready (suitable for MC cable or non-metallic sheath cable)
- Seven finishes available
- Features two water and tamper-resistant receptacles
- Push down to pop-up function is rated for a minimum of 10,000 cycles (OPEN/CLOSE)
- Easy installation - simply drop in and tighten
-   **us** Listed file# E2186



UL498 Section 146

Built and listed to be water resistant to a half gallon of liquid spilled on the device.

NEC 406.5(E)

Receptacle assemblies for installation in countertop surfaces shall be listed for countertop application.

Countertop Receptacles

Ordering Information



Description	Finish	Color/Material	Surface Mount	Flush Mount
15A 125V Tamper-Resistant Pop-Up Kitchen Counter Receptacle, Rated for 20A circuits	Powder Coated	Black White	RCT200BK RCT200W	RCT201BK RCT201W
	Brushed	Aluminum Brass Nickel	RCT200ALU RCT200BR RCT200NI	RCT201ALU RCT201BR RCT201NI
	Polished	Chrome	RCT200CH	RCT201CH
	Matte	Bronze	RCT200BZE	RCT201BZE



Specifications

Performance

Configuration	15 amp 125 volt, Tamper Resistant Receptacle
Circuit Rating	20 amp non-feed through
Listings	cULus Listed to UL498, Section 145 Mechanical Load Test, 146 Spill Test
Dielectric Voltage	Withstands 2,000V minimum
Terminal Accommodation	#14-#12 AWG copper stranded or solid conductor only
Terminal Identification	Terminals identified in accordance with UL 498 and CSA
Flammability	UL 94V-2
Operating Temperature	Maximum continuous 75°C, minimum -40°C (w/o impact)

Materials

Cover and Flange	Die Cast Aluminum
Main Body	Engineered Thermoplastic PBT
Wiring Chamber	Die Cast Aluminum
Water Seals	Elastomers and Silicon

Dimensions Inches (mm)

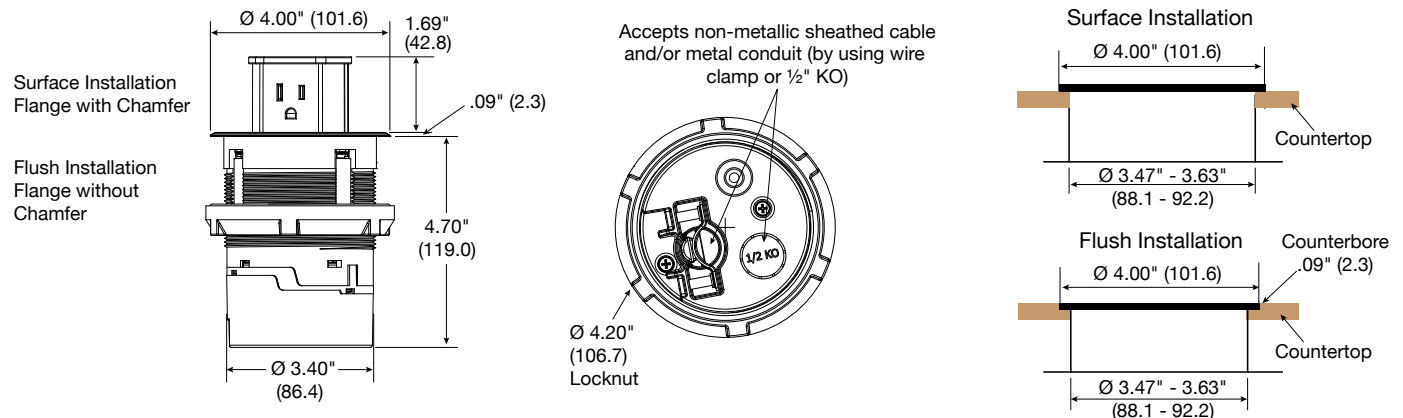

Note: Recommended to be fed by a GFCI circuit, up to 20 Amp Service.