



The Evolution is a highly efficient floodlight that combines Ex de protection with optimised utilisation of light through advanced reflector design. The Evolution concept has no exposed flamepaths making the luminaire effectively maintenance free. Access to the lamp and terminal chamber is achieved by the unscrewing of a single captive bolt.

The Evolution is suitable for use in IIC gas environments.

Ex d e PENDANT HIGH BAY

The Pendant version has simple mounting points and is designed for use in high bay applications.

Standard Specification		Features
Type of Protection	Ex d e (Flameproof, Increased Safety) Dust protected enclosure	Installation in gas groups IIA, IIB and IIC
ATEX Classification	Group II Category 2 GD	Easy and quick access for maintenance
Area Classification	Zone 1 and Zone 21 areas to EN 60079-10-1 and EN 60079-10-2 with installation to EN 60079-14 Gas Groups IIA, IIB and IIC	
Certificate Coding	EC Type Examination Certificate BAS98ATEX2373 Ⓔ II 2 GD Ex d e IIC Refer to table for T rating and Ambient	Simple, rapid lamp replacement and flamepath inspection
Enclosure	Aluminium alloy LM6 to BS 1490 (AC44100) All fastenings A4 stainless steel Toughened glass window	Reduced maintenance due to no exposed flamepath
Reflector Entry	Wide beam, high purity anodised aluminium 2 x M20 cable entries	Exceptional photometric efficiency
Termination	3 core 6mm ² max. conductor with looping	Effective light distribution for many applications
Installation	Stirrup mounting bracket with aiming quadrant	Timed ignitor supplied as standard
Windage	0.159m ² / 0.173m ² (120V version)	
Control Gear	Internal copper/iron with PFC correction capacitor and timed ignitor	
Relamping	Access via hinged end cover on release of single screw	International Approvals
Burning Position	Universal for HID, +/-45° on horizontal plain for Tungsten-Halogen lamps	
Ingress Protection	IP66/67 to EN 60529	
Electrical Supply	220, 230, 240, 254V 50Hz HPS & Metal Halide 24V - 254V ac/dc linear Tungsten-Halogen, 110V - 254V single ended Tungsten-Halogen	ATEX, GOST, CSA, CEPEL and TIS IECEx Compliant

Std. Cat No.	Wattage	Lamp	Lampholder	T Class (Gas)	T °C (Dust)	Ambient °C	Weight
EVOD/150/MS	150W	HPS and Metal Halide	E40	T4	130	40	28.0kg
				T3	175	55	
EVOD/250/MS	250W	HPS and Metal Halide	E40	T4	130	40	28.5kg
				T3	175	55	
EVOD/400/MS	400W	HPS and Metal Halide	E40	T3	175	55	28.5kg
EVOD/600/HS*	600W	HPS	E40	T3	195	35	25.0kg
EVOD/500/TH	500W	Single Ended T/Halogen	E40	T3	195	40	25.0kg
EVOD/500/TL	500W	Linear T/Halogen	R7s	T3	195	55	25.0kg

*Ignitor only fitted. Remote gear box required (see Universal Box).
For Pendant substitute EVPD for EVOD.

Note: Please specify voltage at time of enquiry/order

Options – Suffix to Catalogue No.

/120	110-130V (Weight increase of +12kg) (Extended end cover) HPS & Metal Halide only	/M	Medium beam reflector
/60	60Hz	/P	PTFE coating
/M25	M25 cable entries	/LT	Low temperature version -50°C (Gas groups IIA and IIB only)
/N	Narrow beam reflector	/IEC	Supplied with IECEx certification label

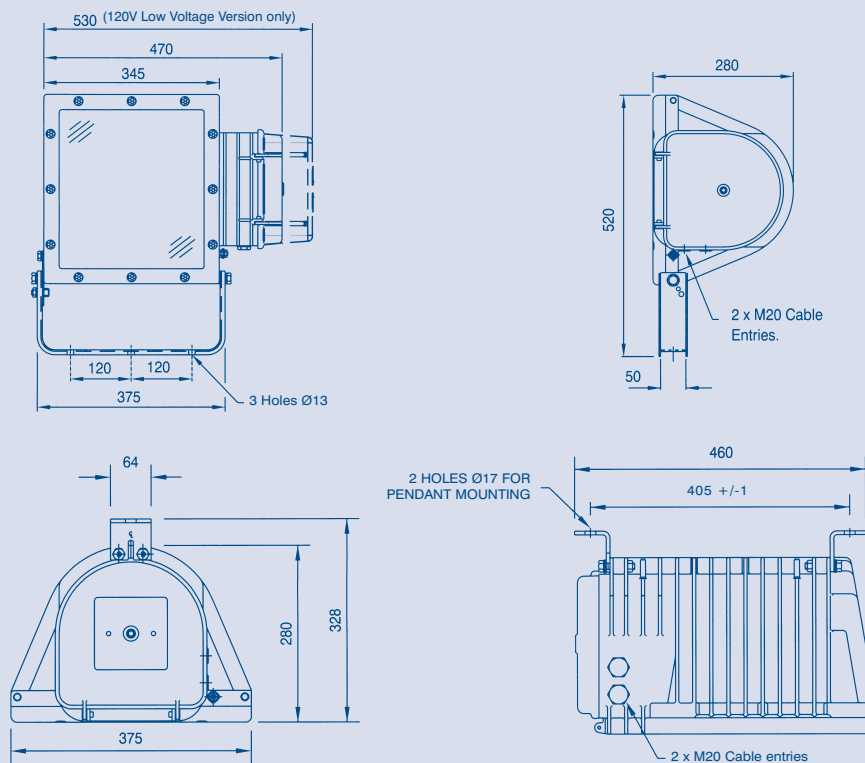

NOTE: 120V version utilises deeper end cover (as shown above)
Available as 220-254V only

Accessories Should be ordered separately

Catalogue Order Code

Product design and specifications are subject to change without notice, please check the Chalmit® website for latest specifications.



EVOLUTION RANGE

3

Evolution II & Evolution Guards and Shields

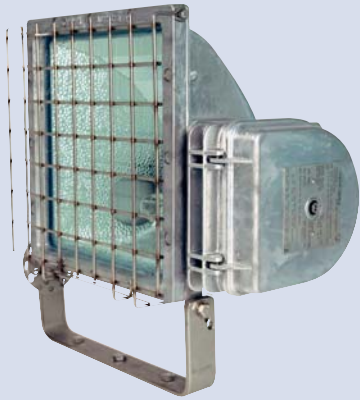

Evolution II	
Wire Guard	SEV04-0020
Combined Anti-Glare Shield and Wire Guard	SEV24-0001
Evolution	
Anti-Glare Shield	SEV04-0002
Wire Guard	SEV04-0003
Combined Anti-Glare Shield and Wire Guard	SEV04-0008

Evolution Anti-Glare Shield

Combined Anti-Glare Shield and Wire Guard

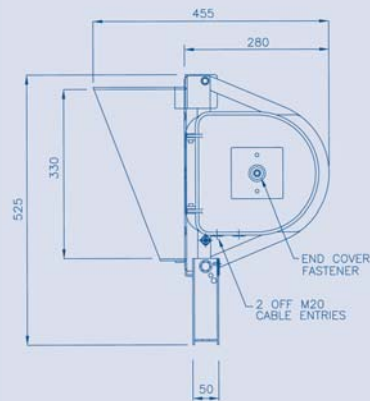
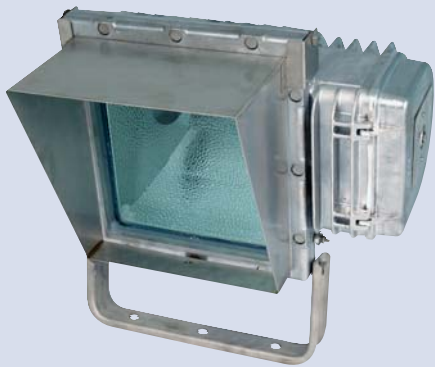

Swing Jib Damper & Bracket Assembly (220-254V only)

Evolution only

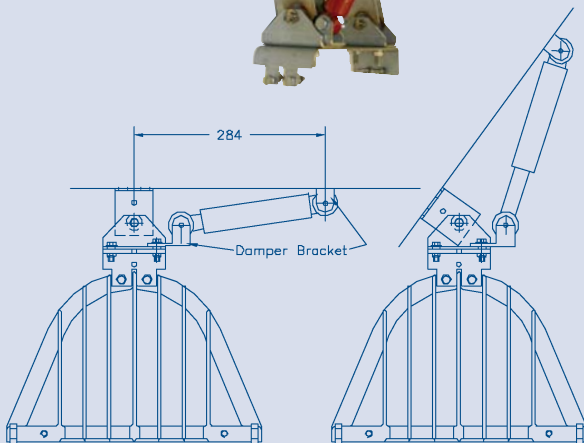
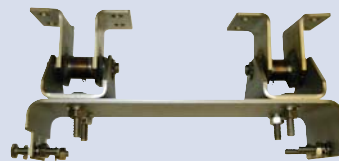

Damper assembly - SEV01-0015

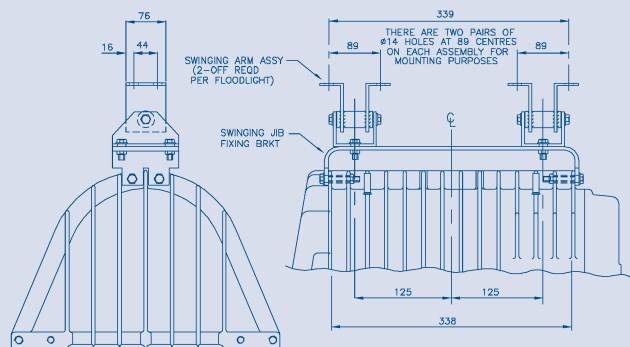

Bracket assembly - SEV04-0009

Pole Mounting Bracket Assembly

Cat No. SEVO4-0001

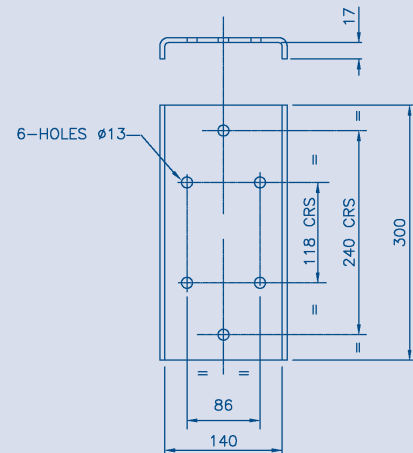
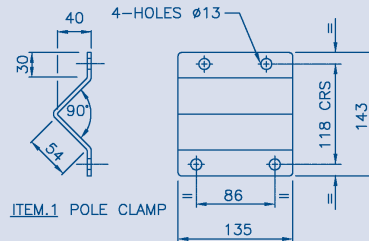

284 Retrofit Bracket

Cat No. SEVO1-0001

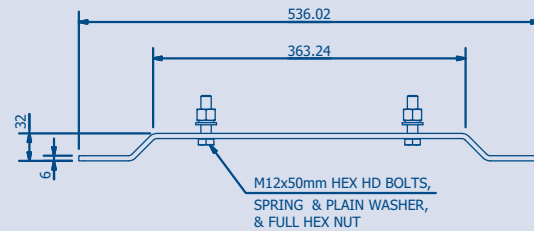
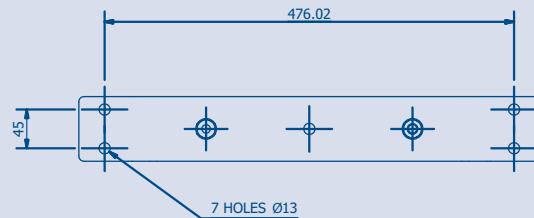

Evolution Junior Mounting Accessories

Cat No. SEVJR-0001/SEVJR-0002



Floor assembly SEVJR-0001



Tripod assembly SEVJR-0002