

SIGNAL REFERENCE GRID (SRG) INSTALLATION INSTRUCTIONS

GENERAL INFORMATION

1. ThermOweld SRG's are shipped in closed trucks unless otherwise specified.
2. Each SRG roll weight is limited to approximately 200 lbs.
3. Each SRG is labeled near the end. The label shows the part number, roll identification and direction in which SRG is to be unrolled when installed.
4. Do not remove plastic wrap from around SRG until ready to install.
5. Several SRG mats may be on the same roll. If more than one mat is placed on a roll, their installation location will be adjacent to each other.

INSTALLATION

1. To avoid placing the SRG where the floor pedestals will be located, mark their location before installing the SRG.
2. Select a corner to begin in and the proper SRG mat per drawing and unroll. Unroll in direction of arrow marked on end of mat.
3. Obstructions can be handled by cutting the SRG to fit around the obstruction or by pulling the SRG around the obstructions and cutting were necessary. Cutting and patching of the SRG is allowed. Use the ThermOweld process to weld cut sections back together.
4. The outside strips of adjacent mats must overlap to be welded together. Use the ThermOweld process to weld the mats together. It is recommended not to weld over the factory welds. If ThermOweld low emission molds are not being used, cover adjacent SRG strip to prevent weld splatter from marring strip.
5. SRG mats may be welded together as you install them or you can wait till the mats are in place then come back and weld all the mats together.
6. Any tears in the SRG (which are rare) caused by installation can be repaired by ThermOwelding.
7. Use the ThermOweld process to make connections between the low impedance risers, pedestal bonds, column bonds, and other metal bonds.
8. After all the ThermOweld connections have been made any buckles in the SRG may be straightened by using pedestal mastic between the SRG and the floor. When SRG is placed near high speed air inlets, use pedestal mastic to hold the SRG in place. Use a mastic that does not contain sulfur. **(Note:** It is important that all ThermOweld connections are made before using pedestal mastic.)

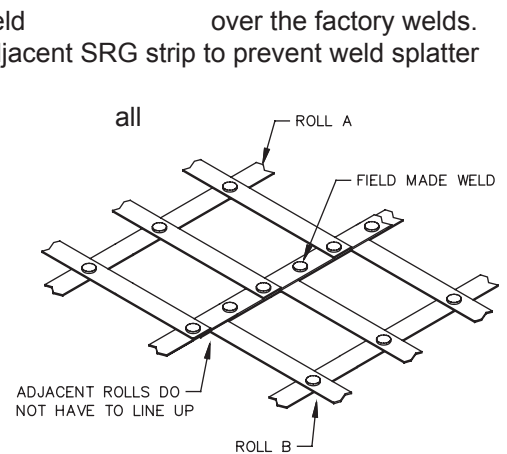

GENERAL NOTES

1. Use caution when walking over SRG. In heavy traffic areas, cover SRG with plywood.
2. Use caution when pulling cables. Place a cloth bag or other protection over the cable ends and connectors to prevent damaging SRG and connectors.

THERMOWELD PROCESS

1. Follow instructions provided with each mold.
2. If ThermOweld low emission molds are not being used, cover adjacent SRG strip to prevent weld splatter from marring strip.

Please Call 1-800-558-1373 if you need assistance with installation.