



# Washer, Electrical Equipment Bond WEEB® WASHER

## Bottom Mounting Installation Instructions for WEEB-FBM516 with Galvanized Purlins only

Burndy LLC recommends that the sufficient details of the installation be submitted to the AHJ for approval before any work is started.



The WEEB® washer family of products can be used to bond anodized aluminum, galvanized steel, steel and other electrically conductive metal structures. All installations shall be in accordance with NEC requirements in the USA and with CSA C22.1 in Canada. The WEEB® washers are for use with modules that have a maximum fuse rating of less than 25A.

### Installation Procedure:

1. Inspect each module frame used with a WEEB® device to ensure that the bottom mounting face of the frame is flat, and that there are no hindrances to embedding WEEB® washer teeth. Do not use a module with a frame that prevents the WEEB® washer teeth from embedding fully.
2. Slide WEEB-FBM516 onto module frame flange as shown in the illustrations below. Visually check that the WEEB® washers are properly positioned.
3. Install one WEEB® washer per module. Once placement of modules is finalized, torque fasteners to minimum of 12ft-lb / 16.3N-m

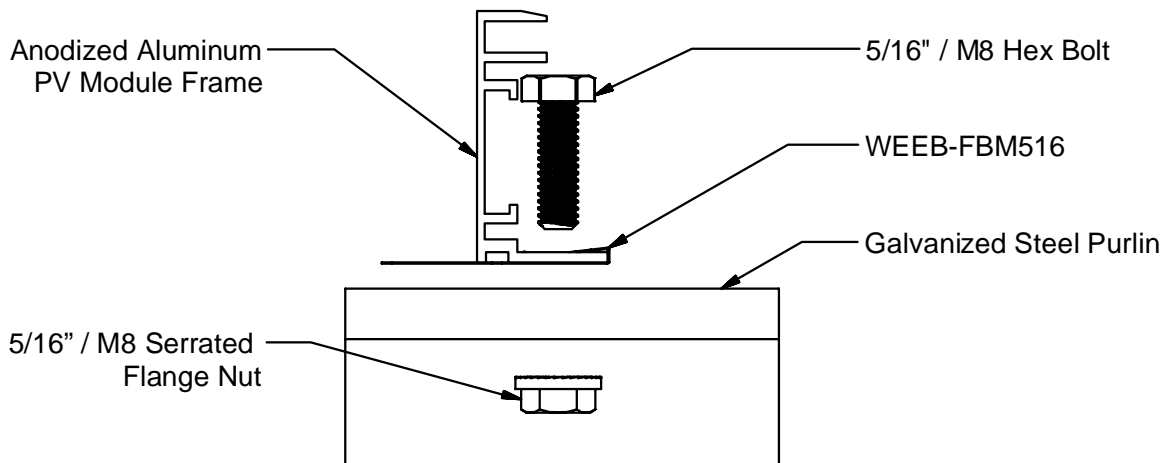

### Important notes:

1. The NEC section 690.43 states "Exposed non-current carrying metal parts of module frames, equipment, and conductor enclosures shall be grounded in accordance with 250.134 or 250.136(A) regardless of voltage".

### Customer Service Department

7 Aviation Park Drive  
 Londonderry, NH 03053  
 1-800-346-4175  
 1-603-647-5299 (International)



4004188

Products are tested to UL 467, CAN/CSA-C22.2 No. 41  
US/ Canadian standards for safety grounding and bonding equipment.

