

Substation



Connecting Power to Your World™

 **BURNDY**

Our Product Solutions

Bolted Fittings

Our bolted terminals, T-connectors, splices and bus supports accommodate nearly any conductor. With various clamping element technologies, BURNDY can provide easy-to-install, range-taking, hassle-free connectors for copper and aluminum substations.

Welded Fittings

BURNDY offers an extensive array of welded connectors for aluminum conductors, including terminals, T-connectors, splices and bus supports, plus A-frames. As with bolted fittings, an expansion line of connectors is available.

EHV Fittings

BURNDY has developed streamlined connectors to accommodate operating voltages of up to 1,100kV. In both bolted and welded configurations, BURNDY® products are designed for corona-free operation at their normal operating range.





Over 85 Years of Experience

Since 1924, BURNDY has been at the forefront of technological innovation. As a result, we offer one of the most widely used and reliable product lines available. We can provide an integrated connector solution for substation projects, from the highest point of the bus structure to the lowest point of the grounding network.

To ensure you have exactly the right products for each specific job, BURNDY has developed unique engineering capabilities and made significant investments in technology such as:

- CAD—providing 3D neutral files
- CAM
- PLM
- PDM
- Simulation
- FEA
- Testing equipment
- Rapid prototyping equipment

Plus, our advanced engineering support teams can custom-build connectors to suit the most intricate of applications. From there, our trained factory sales force is committed to ensuring you have the products you need. In addition, knowledgeable technical support and customer service teams are standing by to answer your questions in person.

About Bern Dibner

The founder of BURNDY®, Bern Dibner, fostered a lifelong dedication to science and technology in part through his collection of rare books and his work as an author. Dibner wrote more than 100 books and articles, including the *Heralds of Science*, a selection of what he considered to be the 200 most important books in the history of science. This collection is considered a valuable reference for students and scholars.



Master Table of Contents

Guide to BURNDY Substation Catalog Numbers	G-1
Copper Terminals	C-1
Copper Couplers	C-21
Copper Bus Supports	C-41
Copper T-Connectors / Tap / A-Frames	C-55
Copper Stud Connectors	C-83
Copper Bus Bars	C-109
Copper End Bells	C-121
Aluminum Bolted Terminals	A-1
Aluminum Bolted Couplers	A-37
Aluminum Bolted Bus Supports	A-61
Aluminum Bolted T-Connectors	A-79
Aluminum Bolted A-Frame Connectors	A-107
Aluminum Bolted Stud Connectors	A-113

Master Table of Contents (continued)

Aluminum Bolted Rigid Spacers	A-133
Aluminum Bolted Shielding Caps/End Caps	A-157
Aluminum Bolted Grounding Studs	A-167
Aluminum Welded Terminals	A-177
Aluminum Welded Couplers	A-209
Aluminum Welded Bus Supports	A-223
Aluminum Welded T / Tap / A-Frames	A-235
Aluminum Welded Stud Connectors	A-249
Aluminum Welded End Caps & Grounding Studs	A-253
References	R-1
Index	I-1

Fundamentals of BURNDY Substation Catalog Numbering System:

Over the years, BURNDY has established an alpha-numeric catalog numbering system/structure to help describe a connector's specific use/application and type or features about the connector. This resource section should be used as a catalog numbering **guideline**. Over the years there have been many exceptions made to the BURNDY Substation Catalog Number System Structure.

The basic anatomy of a catalog number is dependent on the product family, as each family of connectors has different uses / applications and types / features. Because each product family has different uses and types, each product family's numbering scheme may have different attributes to help describe the connector. Below are a few examples of the basic alpha-numeric catalog numbering structure for six different product families.

Product Family				Terminal / Tap
Family	Conductor	Pad	Suffix	
NA	19	A4	GS	
Catalog number structure				NA19A4GS

Product Family				T-Connector
Family	Run	Tap	Suffix	
NT	16	34		
Catalog number structure				NT1634

Product Family				Bus Support
Family	Conductor	Bolt Circle	Suffix	
UHG	20A	3		
Catalog number structure				UHG20A3

Product Family				Coupler
Family	Run	Tap	Suffix	
NL	14	14	8HC	
Catalog number structure				NL14148HC

Product Family				Stud Connector
Family	Stud	Conductor	Suffix	
NDR	655	34	T12	
Catalog number structure				NDR65534T12

Product Family				Spacer
Family	Conductor	Spacing	Suffix	
CP	40A	L4		
Catalog number structure				CP40AL4

BURNDY Catalog Numbering Alpha Character Designations:

Having a fundamental understanding of the alpha character designations is important when trying to interpret the product family, which typically identifies the connector's "use" and "type". Because some alpha characters are used more than once to represent different meanings or as a place holders for product differentiation, it is important that this section be used as a **guideline**. Some alpha characters have two meanings, they can represent a connector's "use" or "type". A "use" designation (white background) would indicate the application the connector would be used in. A "type" designation (blue background) would indicate features about the connector to help describe the connector's function. Some catalog numbers have both "use" and "type" letters combined.

Terminal A	Tap B	Center Pad C	Stud Module D	Inline Coupler E	Flat Bar F
Grounding Stud G	Bus Support H	Heavy Duty H	Cable Expansion K	Elbow L	Body & Cap N
Ring shape (for Bus Sup.) O	Coupler P	Range Taking R	Streamlined S	Sliding Expansion S	T-Connector T
U-Shape U	V-Bolt (Clamping Element) V	Vertical Bus Sup. V	Weldment (Compression) W	Expansion X	Compression Y

Catalog Number Conductor Identification:

Non-Range Taking Connectors:

Typically, following the product family is the conductor size. Depending on the connector family, some connectors accommodate more than one conductor and may list two conductor sizes in the catalog number.

Range Taking Connectors:

Many substation connectors have range taking features. Range taking features allow a connector to accommodate various sizes of conductors. When a connector has a range taking feature, the catalog number will identify the largest conductor that the connector can accommodate.

Examples:



NT**1514** (Non-Range Taking)
N = Cap & Body
T = T-Connector
15 = 1.00" IPS
14 = 3/4" IPS



VV3**40**44N (Range Taking)
VV3 = V-Bolt (accommodating 3 conductors)
A = Terminal
40 = 800 kcmil*
44N = 4" pad with 4 hole NEMA drilling
***Range is 500 - 800 kcmil**

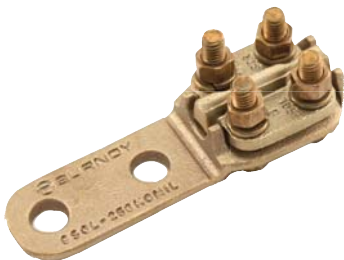

NAS**29**2N (Range Taking)
N = Cap & Body
A = Terminal
S = Streamline
29 = 250 kcmil*
2N = 2 hole NEMA pad
***Range is 6 AWG - 250 kcmil**



NVTT**18**44 (Range Taking)
N = Cap & Body
V = V-Bolt
TT = T-Connector (2 "T" for 2 V-Bolts)
18 = 2.00" IPS (Non-Range Taking)
44 = 1,000 kcmil* (Range Taking)
***Range is 750 - 1,000 kcmil**

PLEASE NOTE:

BURNDY offers Substation connectors that can accommodate aluminum or copper pipe tubing and aluminum or copper cable and in some cases both pipe and cable conductor.

For current carrying purposes, BURNDY connectors are designed to comply with the NEMA CC1.

Connector Material Identification:

Following the conductor size in the catalog number is typically the material designation. When the conductor size is followed by the letter "A", this typically indicates that the connector is made from aluminum. When the conductor is not followed by the letter "A", this indicates that the connector is made of copper or bronze material. Note that in some cases the "A" is not used in the catalog number for aluminum. BURNDY offers Substation connectors that can accommodate aluminum or copper pipe tubing and aluminum or copper cable.

Examples:



NA194N - Copper Terminal
N = Cap & Body
A = Terminal
19 = 2.50" IPS
4N = 4 hole NEMA pad



NA19A4N - Aluminum Terminal
N = Cap & Body
A = Terminal
19 = 2.50" IPS
A = Aluminum
4N = 4 hole NEMA pad



NS1414 - Copper Coupler
N = Cap & Body
S = Streamline
14 = 3/4" IPS
14 = 3/4" IPS



NS14A14A - Aluminum Coupler
N = Cap & Body
S = Streamline
14 = 3/4" IPS
A = Aluminum
14 = 3/4" IPS
A = Aluminum

Terminal Pad Configurations & Catalog Number Designations:

Typically, at the very end of the catalog number is the pad configuration, unless there is a suffix. Terminal pads also have alpha-numeric designations to describe the pad configuration. The standalone or first number describes the number of holes and the second number describes the terminal pad width. The “N” following the number(s) indicates that the pad is a NEMA drilled pad. NEMA is a standard that defines the hole diameters and hole spacing. The table shows the most common terminal pad configurations and the catalog numbering identification alpha-numeric scheme.

Pad description block (regular)	Pad description block (FDs)	Figure	Holes configuration	C - Pad width
2N	B	1	2 holes NEMA	-
4N	-	2	4 holes NEMA	-
34N	C	2	4 holes NEMA	3"
44N	D	3	4 holes NEMA	4"
6N	-	4	6 holes NEMA	-
56N	E	4	6 holes NEMA	5"
66N	F	5	6 holes NEMA	6"

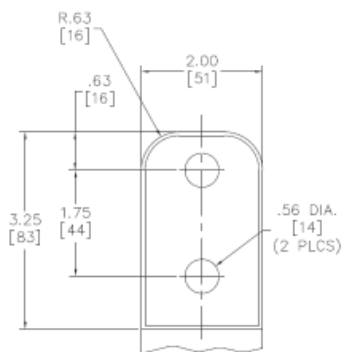

Figure 1

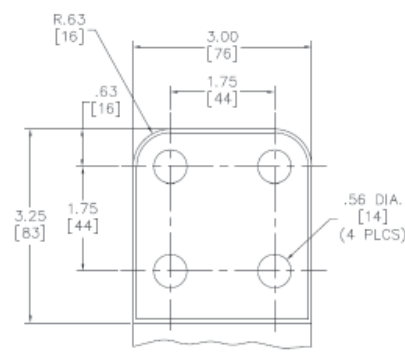

Figure 2

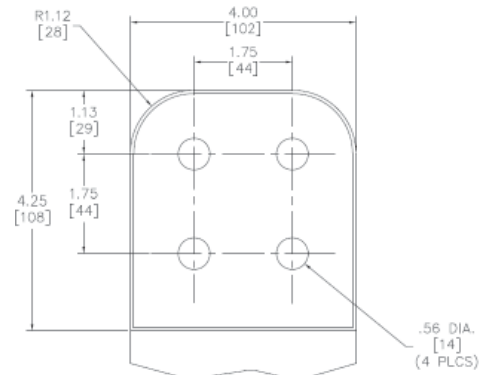

Figure 3

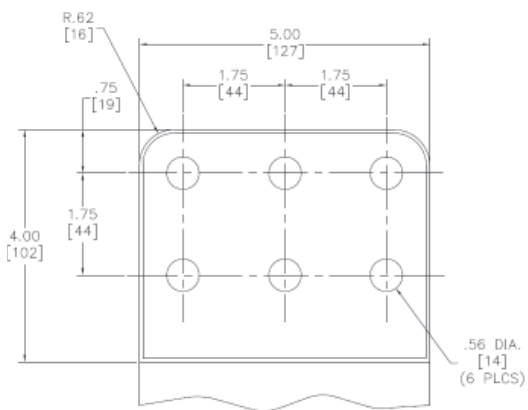

Figure 4

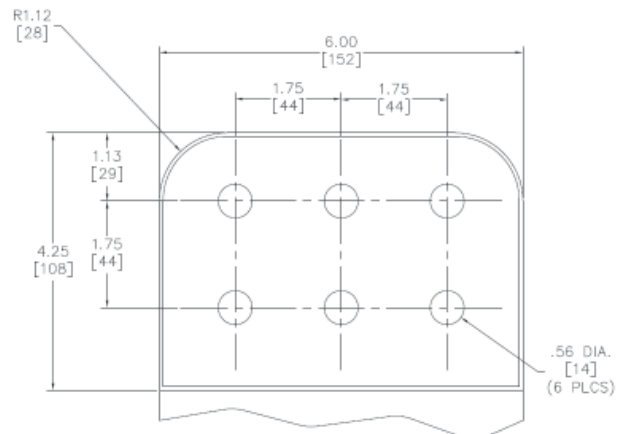

Figure 5

Catalog Number Suffixes:

Many catalog numbers have a suffix to provide additional information. The suffix could identify plating, hardware, operating voltages for streamlined connectors, etc. Below are tables listing the most common suffixes.

Plating Suffixes:

This table lists the most common plating suffixes found in the BURNDY Substation connector line. Example: NAS292N vs. NAS292NTN (Tin plated version of the copper connector)

-TN	Electro tin plating
-BRTN	Bright electro tin plating
-W	Heavy duty electro tin plating (incl. hardware)
-SV	Silver plating
-NK	Nickel plating
-Q	Pad is finished on both sides (used in conjunction with other plating suffix)

Hardware Suffixes:

This table lists the most common hardware suffixes found in the BURNDY Substation connector offering. A catalog number with no hardware suffix will include the standard hardware for both copper and aluminum connectors.

Example: NNE14A34A vs. NNE14A34ASS (Coupler with Stainless Steel hardware)

-GS	Galvanized Steel hardware
-SS	Stainless Steel hardware
-BW	Belleville Washer
-CH	Antistatic Chatter Spring
-HC	Hex Captured hardware

Operating Voltage for Streamlined Connector Suffixes:

This table lists the most common operating voltage suffixes found in the BURNDY Substation offering. Example: SNNE86A445A vs. SNNE86A445AS3 (S3 designates the terminal is rated for 345kV)

-S3	345kV rating
-K	cable versions for expansion items, 345kV
-S7	765V rating

G# and CG# Suffixes:

G# and CG# suffixes are used when a customer requests a connector that is similar to a product in the standard product offering, but deviates to be a standalone product within a particular family. To name these "special" connectors, BURNDY will add a G# or CG# suffix.

Example: NNE14A34AG1 or NNE14A34ACG1

Stud Connector Catalog Numbering:

Stud connectors have a different catalog numbering system in comparison to the other product families previously mentioned.

Examples:

Family	Stud Diameter	Pad Size	Pad thickness (in 1/16 of an inch)	Threads per inch of the stud (if different than 12)
FD	70	D	12	T14
Stud	3" Stud	4"x4" NEMA pad	12/16 = 3/4" thick tongue	14 threads per inch

FD70D12T14

F = Flat bar
 D = Stud module
 70 = 3" Stud size
 D = Pad size per Pad Description block
 12 = Tongue thickness (12/16" = 3/4" thick)
 T14 = 14 Threads per inch



Family	Stud Diameter	Conductor	Threads per inch of the stud (if different than 12)
NDR	63	28	T13
Stud	1/2" Stud	4/0	13 threads per inch

NDR6328T13

N = Body & Cap
 D = Stud module
 R = Range taking
 63 = 1/2" Stud size
 28 = 4/0 (Range 6 AWG - 4/0)
 T13 = 13 Threads per inch

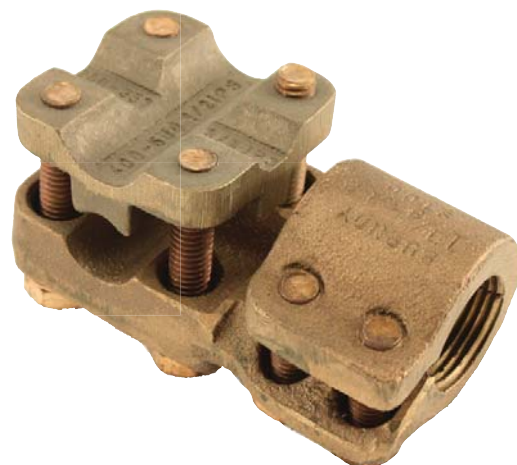
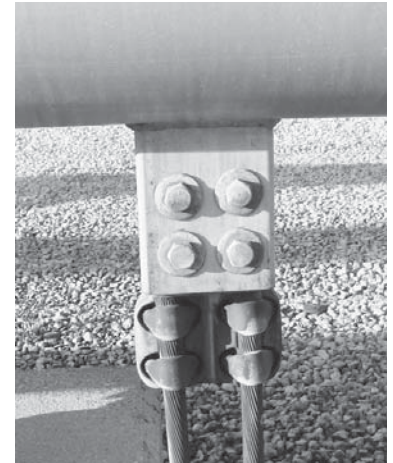

Table of Contents - Copper Terminals

	Type NAS Cable to Pad	C-3
	Type NAH Cable to Pad	C-4
	Type N2AH 2 Cables to Pad	C-7
	Type NA Pipe to Pad	C-9
	Type NAC Pipe to Pad	C-11
	Type VA Cable to Pad	C-12
	Type VVA Cable to Pad	C-13
	Type VV2A Cable to Pad	C-14
	Type VV3A Cable to Pad	C-15
	Type VF Cable to Pad	C-16
	Type XA Pipe to Pad	C-17
	Type NFXR Pipe or Cable to Pad	C-18
	Type NBXR Pipe or Cable to Pad	C-19
	Type NNBXR Pipe or Cable to Pad	C-20



TYPE NAS BOLTED TERMINALS

For Use On CABLE TO PAD

High copper alloy reversible cap terminal for joining a wide range of cable to pads. Tongue is side formed to provide adequate clearance and terminal is designed for one-wrench installation.



Material: Copper Alloy
Hardware: DURIMUM™ Silicon Bronze

Notes :

- Plated versions: add the required suffix to the catalog number. -TN for regular tin plating
- Please contact factory for other sizes, combinations and availability
- See NAH family for heavy duty versions.

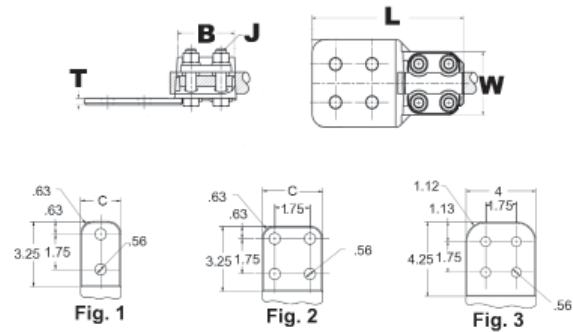

Catalog Number	Fig. #	Copper Stranded Range	Copper Solid Range	B	J Dia.	L	C	T	W
NAS292N	1	6 AWG-250 kcmil	6 AWG-4/0 AWG	2.38	3/8	5.62	1.50	0.25	2.00
NAS2934N	2			2.38	3/8	5.62	3.00	0.25	2.00
NAS29N	—			2.38	3/8	3.88	1.25	0.25	2.00
NAS342N	1	1/0 -500 kcmil	1/0 AWG-4/0 AWG	2.38	3/8	5.62	2.00	0.31	2.20
NAS3434N	2			2.38	3/8	5.62	3.00	0.25	2.20
NAS34N	—			2.38	3/8	4.12	1.50	0.25	2.20
NAS402N	1	2/0 AWG-800 kcmil	2/0 AWG-4/0 AWG	2.62	3/8	5.88	2.00	0.38	2.44
NAS4034N	2			2.62	3/8	5.88	3.00	0.31	2.44
NAS4044N	3			2.62	3/8	6.88	4.00	0.31	2.44

TYPE NAS 45/90° BOLTED TERMINALS

For Use On CABLE TO ANGLED PAD

High copper alloy reversible cap terminal for joining a wide range of cable to oriented pads. Tongue is side formed to provide adequate clearance and terminal is designed for one-wrench installation.

Material: Copper Alloy
Hardware: DURIMUM™ Silicon Bronze

Notes :

- Plated versions: add the required suffix to the catalog number. -TN for regular tin plating
- Please contact factory for other sizes, combinations and availability
- Other pad configurations are available (i.e.: suffix -30 for a 30 degree pad, etc.)
- See NAH family for heavy duty versions.

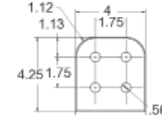
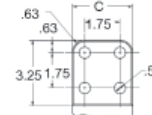
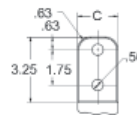
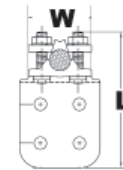
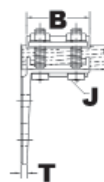

Fig. 1

Fig. 2

Fig. 3

Catalog Number	Fig. #	Pad Angle	Copper Stranded Range	Copper Solid Range	B	J Dia.	L	C	T	W
NAS292N90	1	90°	6 AWG-250 kcmil	6 AWG-4/0 AWG	2.38	3/8	2.47	1.50	0.25	2.00
NAS2934N90	2				2.38	3/8	2.47	3.00	0.25	2.00
NAS29N90	—				2.38	3/8	2.38	1.25	0.25	2.00
NAS342N90	1		1/0 AWG-500 kcmil	1/0 AWG-4/0 AWG	2.38	3/8	2.53	2.00	0.31	2.20
NAS3434N90	2				2.38	3/8	2.47	3.00	0.25	2.20
NAS4034N45	2	45°	2/0 AWG-800 kcmil	2/0 AWG-4/0 AWG	2.55	3/8	5.56	3.00	0.31	2.42

**TYPE NAH
BOLTED TERMINALS**

For Use On CABLE TO PAD

High copper alloy terminal for joining a wide range of cable to equipment pads. Tongue is side formed to provide adequate clearance and terminal is designed for one-wrench installation.



Material: Copper Alloy
Hardware: DURIMUM™ Silicon Bronze

Notes :

- Plated versions: add the required suffix to the catalog number. -TN for regular tin plating
- Please contact factory for other sizes, combinations and availability

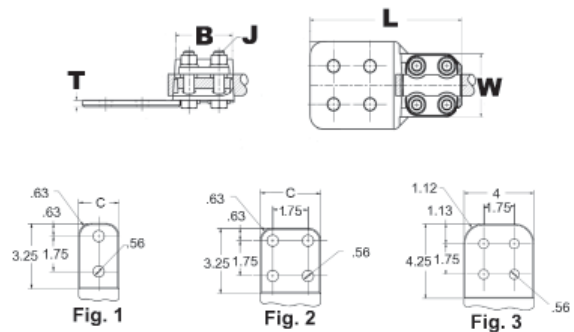

Catalog Number	Fig. #	Copper Stranded Range	Copper Solid Range	B	J Dia.	L	C	T	W
NAH292N	1	6-250	6-4/0	2.62	1/2	5.88	1.50	0.25	2.44
NAH2934N	2	6-250	6-4/0	2.62	1/2	5.88	3.00	0.25	2.44
NAH342N	1	1/0-500	1/0-4/0	2.62	1/2	5.88	2.00	0.31	2.56
NAH3434N	2	1/0-500	1/0-4/0	2.62	1/2	5.88	3.00	0.25	2.56
NAH402N	1	2/0-800	3/0-4/0	2.62	1/2	5.88	2.00	0.38	2.81
NAH4034N	2	2/0-800	3/0-4/0	2.62	1/2	5.88	3.00	0.31	2.81
NAH4044N	3	2/0-800	3/0-4/0	2.62	1/2	6.88	4.00	0.31	2.81
NAH442N	1	4/0-1000	N/A	2.88	1/2	6.12	2.00	0.44	2.88
NAH4434N	2	4/0-1000	N/A	2.88	1/2	6.12	3.00	0.38	2.88
NAH4444N	3	4/0-1000	N/A	2.88	1/2	7.12	4.00	0.31	2.88
NAH462N	1	1000-1500	N/A	3.06	1/2	6.31	2.00	0.50	3.19
NAH4634N	2	1000-1500	N/A	3.06	1/2	6.31	3.00	0.41	3.19
NAH4644N	3	1000-1500	N/A	3.06	1/2	7.31	4.00	0.38	3.19
NAH482N	1	500-2000	N/A	3.25	1/2	6.50	2.00	0.69	3.38
NAH4834N	2	500-2000	N/A	3.25	1/2	6.50	3.00	0.50	3.38
NAH4844N	3	500-2000	N/A	3.25	1/2	7.50	4.00	0.44	3.38
NAH4862N	1	2000-2500	N/A	3.75	5/8	7.12	3.00	0.63	3.96
NAH48634N	2	2000-2500	N/A	3.75	5/8	7.12	3.00	0.63	3.96

TYPE NAH 45/90° BOLTED TERMINALS

For Use On CABLE TO ANGLED PAD

High copper alloy reversible cap terminal for joining a wide range of cable to oriented pads. Tongue is side formed to provide adequate clearance and terminal is designed for one-wrench installation. 1/2" hardware provided for heavy duty application.

Material: Copper Alloy
Hardware: DURIMUM™ Silicon Bronze

Notes :

- Plated versions: add the required suffix to the catalog number. -TN for regular tin plating
- Please contact factory for other sizes, combinations and availability
- Other pad configurations are available (i.e.: suffix -30 for a 30 degree pad, etc.)

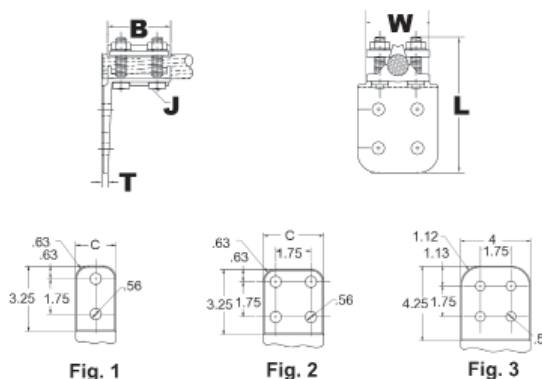

Catalog Number	Fig. #	Pad Angle	Copper Stranded Range	Copper Solid Range	B	T	J Dia.	L	C	W
NAH292N45	1	45°	6-250	6-4/0	2.62	0.25	1/2	5.12	1.50	2.44
NAH342N45	1		1/0-500	1/0-4/0	2.62	0.31	1/2	5.27	2.00	2.56
NAH4034N45	2		2/0-800	3/0-4/0	2.62	0.32	1/2	5.56	3.00	2.78
NAH442N45	1		4/0-1000	N/A	2.81	0.44	1/2	5.81	2.00	2.90
NAH4434N45	2		4/0-1000		2.88	0.38	1/2	5.79	3.00	2.90
NAH292N90	1	90°	6-250	6-4/0	2.62	0.25	1/2	2.69	1.50	2.44
NAH342N90	1		1/0-500	1/0-4/0	2.62	0.31	1/2	2.75	2.00	2.56
NAH3434N90	2				2.62	0.25	1/2	2.69	3.00	2.56
NAH402N90	1		2/0-800	3/0-4/0	2.62	0.38	1/2	2.82	2.00	2.81
NAH4034N90	2				2.62	0.31	1/2	2.75	3.00	2.81
NAH442N90	1		4/0-1000	N/A	2.88	0.44	1/2	3.17	2.00	2.88
NAH4434N90	2				2.88	0.38	1/2	3.11	3.00	2.88
NAH4844N90	3				500-2000	3.25	0.44	1/2	3.50	4.00

**TYPE N2AH
BOLTED TERMINALS**

For Use On (2) COPPER CABLES TO PAD

High copper alloy reversible cap terminal for joining a wide range of cable to pads. Tongue is side formed to provide adequate clearance and terminal is designed for one-wrench installation.



Material: Copper Alloy
Hardware: DURIMUM™ Silicon Bronze

Notes :

- Plated versions: add the required suffix to the catalog number. -TN for regular tin plating
- Please contact factory for other sizes, combinations and availability

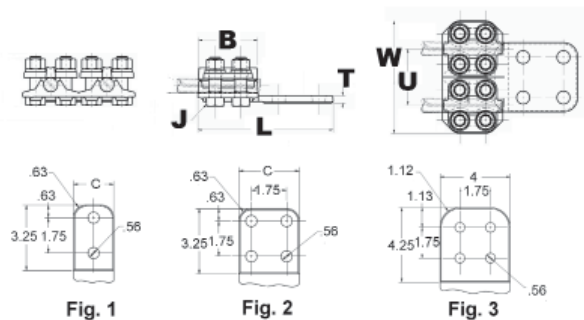

Catalog Number	Fig. #	Copper Stranded Range	Copper Solid Range	B	J Dia.	L	C	T	W	U
N2AH292N	1	6-250	6-4/0	2.62	1/2	5.87	1.50	0.32	4.88	2.44
N2AH2934N	2	6-250	6-4/0	2.62	1/2	5.87	3.00	0.32	4.88	2.44
N2AH342N	1	1/0-500	1/0-4/0	2.62	1/2	5.87	2.00	0.32	5.44	2.88
N2AH3434N	2	1/0-500	1/0-4/0	2.63	1/2	6.13	3.00	0.38	5.40	2.88
N2AH3444N	3	1/0-500	1/0-4/0	2.63	1/2	7.00	4.00	0.38	5.38	2.88
N2AH4034N	2	2/0-800	2/0-4/0	2.63	1/2	5.88	3.00	0.38	5.70	2.92
N2AH4434N	2	4/0-1000	4/0	2.88	1/2	6.38	3.00	0.50	6.12	3.12
N2AH4444N	3	4/0-1000	4/0	2.88	1/2	7.32	4.00	0.50	6.12	3.12
N2AH4444NHQ	3	4/0-1000	4/0	2.88	1/2	7.20	4.00	0.50	6.12	3.12
N2AH4644N	3	1000-1500	N/A	3.07	1/2	7.46	4.00	0.75	6.50	3.36
N2AH4844N	3	1000-1500	N/A	3.25	1/2	7.62	4.00	0.75	9.50	4.00

TYPE N2AH 45/90° BOLTED TERMINALS

For Use On (2) CABLES TO ORIENTED PAD

High copper alloy reversible cap terminal for joining a wide range of two copper cables to pads. Tongue is oriented to a given angle from straight reference (30°, 45°, 90°...) to provide adequate clearance. Terminal is designed for one-wrench installation.

Material: Copper Alloy

Hardware: DURIMUM™ Silicon Bronze

Notes :

- Plated versions: add the required suffix to the catalog number. -TN for regular tin plating
- Please contact factory for other sizes, combinations and availability

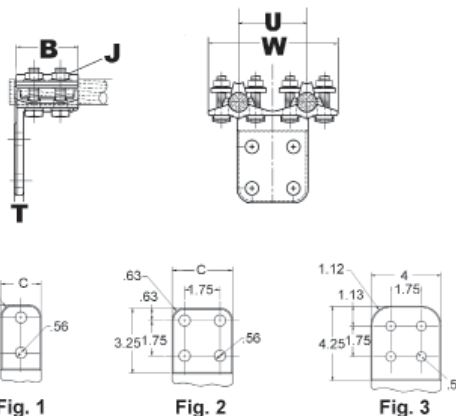

Catalog Number	Fig. #	Pad Angle	Copper Stranded Range	Copper Solid Range	B	J Dia.	W	U		
N2AH342N90	1	90°	1/0 AWG-500 kcmil	1/0 AWG-4/0 AWG	2.62	1/2	5.44	2.88		
N2AH3434N90	2				2.62	1/2	5.44	2.88		
N2AH3444N90	3				2.63	1/2	5.38	2.88		
N2AH402N90	1		2/0 AWG-800 kcmil	2/0 AWG-4/0 AWG	2.63	1/2	5.70	2.92		
N2AH4034N90	2				2.63	1/2	5.70	2.92		
N2AH4434N90	2				4/0 AWG-1000 kcmil	4/0 AWG	2.88	1/2	4.69	3.12
N2AH4444N90	3						2.88	1/2	6.12	3.12
N2AH4844N90	3	1000 kcmil-1500 kcmil	N/A	3.25	1/2	9.50	4.00			
N2AH292N45	1	45°	6 AWG-250 kcmil	6 AWG-4/0 AWG	2.62	1/2	4.88	2.44		
N2AH4434N45	2		4/0 AWG-1000 kcmil	4/0 AWG	2.88	1/2	4.69	3.12		
N2AH4444N45	3				2.88	1/2	6.12	3.12		

TYPE NA BOLTED TERMINALS

For Use On PIPE TO PAD

High copper alloy terminal for joining copper tube to a flat pad. Letter “N” suffix on end of catalog number indicates pad drilled to NEMA standards. One-wrench installation.

Material: Copper Alloy
Hardware: DURIMUM™ Silicon Bronze

Notes :

- Plated versions: add the required suffix to the catalog number. -TN for regular tin plating
- Please contact factory for other sizes, combinations and availability

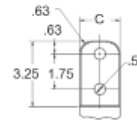
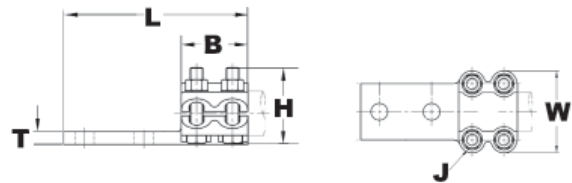
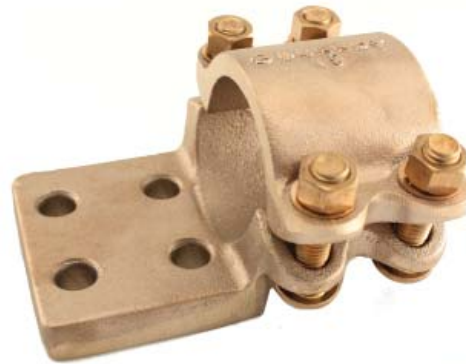

Fig. 1

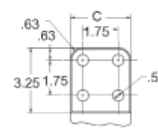

Fig. 2

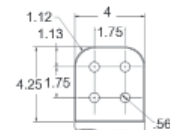

Fig. 3

Catalog Number	Fig. #	Copper Pipe (Std or EH)	B	J Dia.	L	H	C	T	W
NA122N	1	3/8 IPS	1.38	3/8	3.75	1.50	1.50	0.25	2.13
NA132N	1	1/2 IPS	2.00	3/8	5.25	1.75	1.50	0.38	2.25
NA142N	1	3/4 IPS	2.00	3/8	5.25	2.00	1.63	0.38	2.44
NA144N	2		2.00	3/8	4.50	2.00	3.13	0.38	2.44
NA152N	1	1 IPS	2.00	3/8	5.25	2.06	1.88	0.38	2.75
NA154N	2		2.00	3/8	5.25	2.06	3.00	0.38	2.75
NA162N	1	1 1/4 IPS	2.69	1/2	5.94	2.56	2.25	0.44	3.50
NA164N	2		2.69	1/2	5.94	2.56	3.00	0.44	3.50
NA172N	1	1 1/2 IPS	2.69	1/2	5.94	2.75	2.50	0.50	3.94
NA1744NHQ	3		2.69	1/2	7.07	3.09	4.00	0.50	3.82
NA174N	2		2.69	1/2	5.94	2.75	3.00	0.50	3.94
NA182N	1	2 IPS	2.69	1/2	5.94	3.12	2.75	0.50	4.62
NA184N	2		2.69	1/2	5.94	3.13	3.13	0.50	4.63
NA1944N	3	2 1/2 IPS	2.69	1/2	7.19	3.74	4.00	0.69	5.24
NA1944NHQ	3	2 1/2 IPS	2.69	1/2	7.09	3.96	4.00	0.75	5.12
NA194N	2		2.69	1/2	5.94	3.69	3.75	0.69	5.25
NA194N90CG2	2	2 1/2 IPS	2.69	1/2	6.50	3.62	3.75	0.69	5.25
NA204N	2	3 IPS	3.25	5/8	6.56	4.38	4.38	0.69	6.19
NA214N	2	3 1/2 IPS	3.25	5/8	6.56	4.94	4.75	0.81	6.81
NA224N	2	4 IPS	3.25	5/8	6.56	5.50	5.25	0.81	7.44

TYPE NA 45/90° BOLTED TERMINALS

For Use On PIPE TO ANGLED PAD

High copper alloy terminal for joining copper tube to a flat pad. Tongue is oriented to a given angle from straight reference (30°, 45°, 90°...) to provide adequate clearance. Designed to accommodate standard and extra heavy (EH) pipes. One-wrench installation.

Material: Copper Alloy
Hardware: DURIUM™ Silicon Bronze

Notes :

- Plated versions: add the required suffix to the catalog number. -TN for regular tin plating
- Please contact factory for other sizes, combinations and availability
- Items with -HC suffix have hex head bolts; items without the suffix can be either hex head or oval shank head. Both head styles are one wrench installation and offer the same clamping force and functionalities.

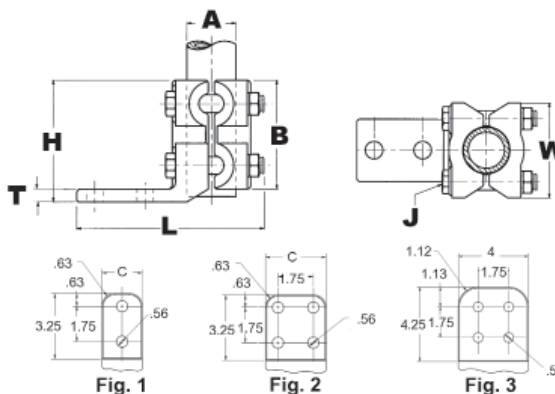

Catalog Number	Fig. #	Pad Angle	Copper Pipe (Std or EH)	B	J Dia.	H	T	L	C	W
NA132N90	1	90°	1/2 IPS	2.00	3/8	2.50	0.31	4.81	1.50	2.25
NA142N90	1	90°	3/4 IPS	2.00	3/8	2.50	0.38	5.61	1.63	2.84
NA144N90	2	90°	3/4 IPS	2.00	3/8	5.09	0.38	2.62	3.00	2.44
NA152N90	2	90°	1 IPS	2.00	3/8	2.56	0.38	5.21	1.88	2.75
NA154N90	2	90°	1 IPS	2.00	3/8	2.56	0.38	5.21	3.00	2.75
NA162N90	1	90°	1 1/4 IPS	2.69	1/2	3.31	0.44	5.72	2.25	3.50
NA164N90	2	90°	1 1/4 IPS	2.69	1/2	3.31	0.44	5.22	3.00	3.50
NA172N90	1	90°	1 1/2 IPS	2.69	1/2	3.38	0.50	5.86	2.50	3.94
NA174N90	2	90°	1 1/2 IPS	2.69	1/2	3.38	0.50	5.86	3.00	3.94
NA1744N90HQ	3	90°	1 1/2 IPS	2.69	1/2	3.38	0.50	7.25	4.00	4.52
NA182N90	1	90°	2 IPS	2.69	1/2	3.44	0.50	6.19	2.75	4.62
NA184N90	2	90°	2 IPS	2.69	1/2	3.44	0.50	6.19	3.12	4.62
NA184N90HC	2	90°	2 IPS	2.69	1/2	6.19	0.50	3.44	3.12	4.62
NA194N90	2	90°	2 1/2 IPS	2.69	1/2	3.62	0.69	6.47	3.75	5.25
NA194N90CG2	2	90°	2 1/2 IPS	2.69	1/2	6.50	0.69	3.62	3.75	5.25
NA1944N90HQ	2	90°	2 1/2 IPS	2.69	1/2	3.29	0.75	7.82	4.00	5.12
NA214N90	2	90°	3 1/2 IPS	3.25	5/8	4.31	0.81	7.53	4.75	6.81
NA2244N90	3	90°	4 IPS	3.25	5/8	4.11	0.75	7.81	4.20	7.44

TYPE NAC BOLTED TERMINALS

For Use On PIPE TO CENTERLINE
PAD

High copper alloy terminal for joining copper tube to a centerline flat pad. Designed to accommodate standard and extra heavy (EH) pipes. One-wrench installation.

Material: Copper Alloy
Hardware: DURIMUM™ Silicon Bronze Hardware

Notes :

- Plated versions: add the required suffix to the catalog number. -TN for regular tin plating
- Please contact factory for other sizes, combinations and availability
- For 90 degree pad add suffix -90; for 45 degree pad add suffix -45 to the catalog number. For other angles contact factory.

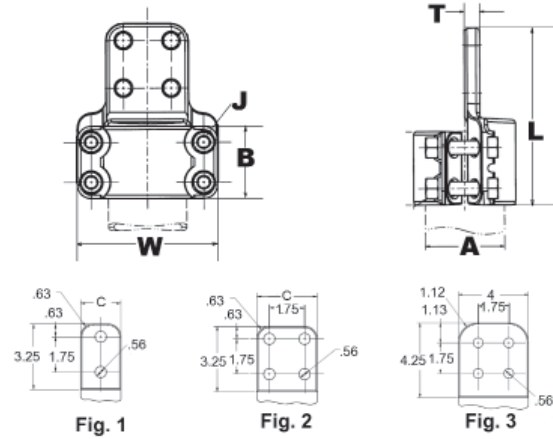
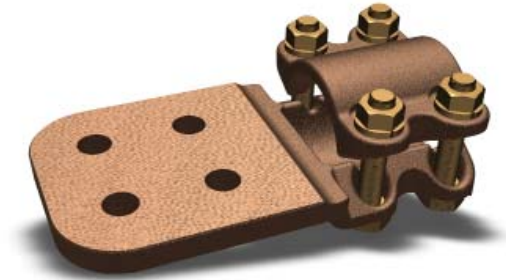

Catalog Number	Fig. #	Copper Pipe (Std or EH)	B	J Dia.	L	C	T	W
NAC1734N	2	1 1/2 IPS	2.69	1/2	6.42	3.00	0.50	3.82
NAC1744N	3		2.69	1/2	7.42	4.00	0.50	3.82
NAC1834N	2	2 IPS	2.69	1/2	6.46	3.00	0.50	4.50
NAC1844N	3		2.69	1/2	7.46	4.00	0.50	4.50

**TYPE VA
VARILUG™**

For Use On COPPER CABLE

High copper alloy terminal for joining a wide range of cable to equipment pads or bar. Particularly suitable for use on extra flexible cable. One-wrench installation. One-wrench installation.

Material: Bronze Alloy
Hardware: DURIMUM™ Silicon Bronze

Notes :

- Plated versions: add the required suffix to the catalog number. -TN for regular tin plating
- Please contact factory for other sizes, combinations and availability
- Choose type VVA with twin elements for additional joint strength against vibration and flexing. Particularly recommended for use on flexible cables.

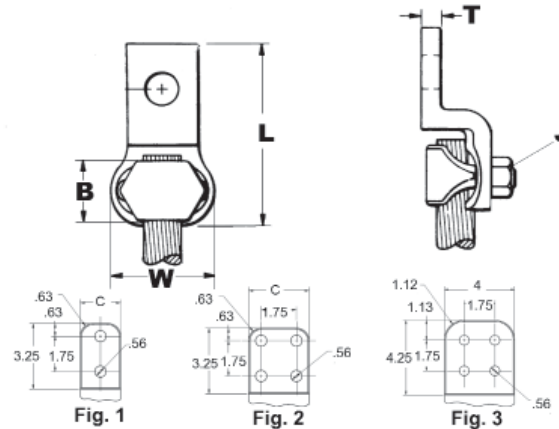

Catalog Number	Fig. #	Copper Stranded Range	Copper Solid Range	C	B	J Dia.	L	T	W
VA4C	—	8-4	8-4	0.75	0.69	7/16	2.38	0.22	0.81
VA2C	—	8-2	8-2	0.81	0.81	3/8	2.72	0.25	1.00
VA25	—	6-1/0	6-1/0	0.88	0.88	3/8	2.88	0.25	1.19
VA252	—			0.88	0.88	3/8	3.63	0.25	1.19
VA28	—	1/0-4/0	1/0-4/0	1.06	1.09	3/8	2.84	0.31	1.69
VA282N	1			1.06	1.09	3/8	4.94	0.31	1.69
VA30	—	1/0-300	1/0-4/0	1.13	1.09	3/8	3.22	0.31	1.91
VA302N	1			1.12	1.09	7/16	5.19	0.31	1.91
VA34	—	300-500	N/A	1.38	1.31	1/2	3.81	0.38	2.22
VA342N	1			1.38	1.31	1/2	5.38	0.38	2.22
VA344	—			1.88	1.31	7/16	4.22	0.38	2.22
VA40	—	500-800	N/A	1.63	1.34	9/16	4.47	0.38	2.63
VA402N	1			1.62	1.34	9/16	5.81	0.38	2.62
VA404	—			1.88	1.34	9/16	4.72	0.38	2.63
VA404N	2			3.00	1.34	9/16	5.81	0.38	2.62
VA44	—	750-1000	N/A	1.88	1.41	5/8	4.78	0.50	2.88
VA444	—			2.13	1.41	5/8	5.16	0.50	2.88
VA462N	1			2.25	2.00	5/8	6.44	0.56	3.25

**TYPE VVA
VARILUG™**

For Use On COPPER CABLE

High copper alloy terminal for joining a wide range of cable to equipment pads or bar. Particularly suitable for use on extra flexible cable. One-wrench installation.

Material: Bronze Alloy
Hardware: DURIUM™ Silicon Bronze

Notes :

- Plated versions: add the required suffix to the catalog number. -TN for regular tin plating
- Please contact factory for other sizes, combinations and availability

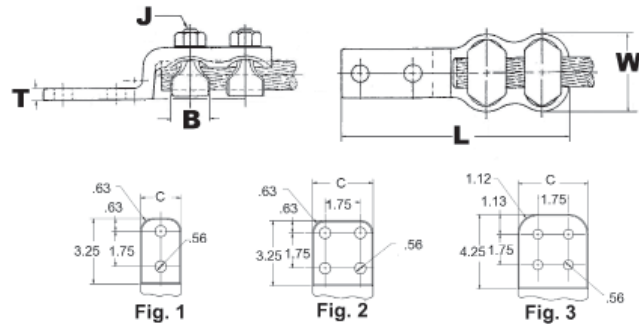
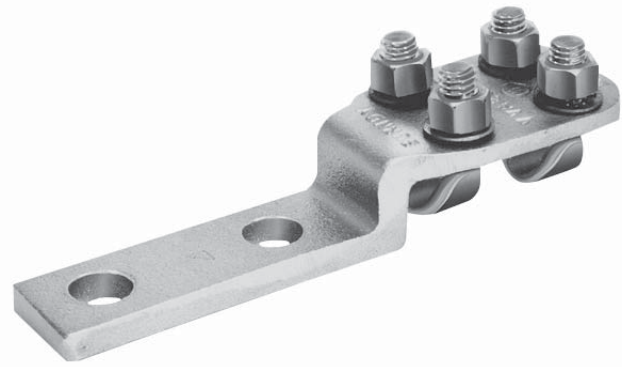

Catalog Number	Fig. #	Copper Stranded Range	Copper Solid Range	C	B	J Dia.	L	T	W
VVA2C	—	8-2	8-2	0.81	0.81	3/8	4.06	0.25	1.00
VVA25	—	6-1/0	6-1/0	0.88	0.88	3/8	4.31	0.25	1.19
VVA252	—	1/0-4/0		0.88	0.88	3/8	5.06	0.25	1.19
VVA28	—		1/0-4/0	1.06	1.09	3/8	4.13	0.31	1.69
VVA282N	1	300		1.06	1.09	3/8	6.19	0.31	1.69
VVA30	—		1/0-4/0	1.13	1.09	7/16	4.63	0.31	1.94
VVA302N	1	300-500		1.13	1.09	7/16	6.56	0.31	1.94
VVA304N	2		300-500	3.00	1.09	7/16	6.75	0.38	1.91
VVA34	—	300-500		1.38	1.31	1/2	5.31	0.38	2.25
VVA342N	1		300-500	1.30	1.31	1/2	6.88	0.38	2.22
VVA344	—	300-500		1.88	1.31	7/16	5.75	0.38	2.25
VVA344N	2		300-500	3.13	1.31	7/16	7.00	0.38	2.38
VVA40	—	500-800		1.63	1.34	9/16	6.38	0.38	2.63
VVA402N	1		500-800	1.62	1.34	9/16	7.69	0.38	2.62
VVA404N	2	500-800		3.00	1.34	9/16	7.69	0.38	2.62
VVA404NCG1	—		750-1000	3.50	0.88	9/16	7.69	0.38	2.62
VVA442N	1	750-1000		1.88	1.41	5/8	8.12	0.50	2.88
VVA444N	2		750-1000	3.00	1.41	5/8	8.06	0.50	2.88
VVA462N	1	1000-1500		2.25	2.00	5/8	8.69	0.56	3.25
VVA464NCG2	—	1000-1500	3.50	2.00	5/8	8.75	0.56	3.25	
VVA464NCG4	—	1000-1500	3.50	2.00	5/8	5.50	0.56	3.23	
VVA482N	1	1500-2000	2.62	2.25	3/4	9.23	0.62	3.75	

**TYPE VV2A
VARILUG™**

For Use On (2) CABLES TO PAD

Twin V elements to secure joint against vibration and flexing. Particularly recommended for use on extra flexible cables. One-wrench installation.

Material: Copper Alloy
Hardware: DURIMUM™ Silicon Bronze

Notes :

- Plated versions: add the required suffix to the catalog number. -TN for regular tin plating
- Please contact factory for other sizes, combinations and availability

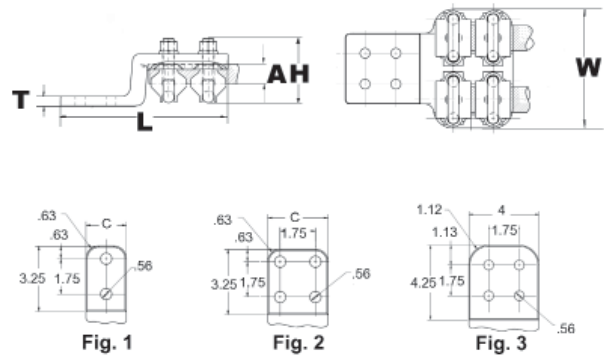
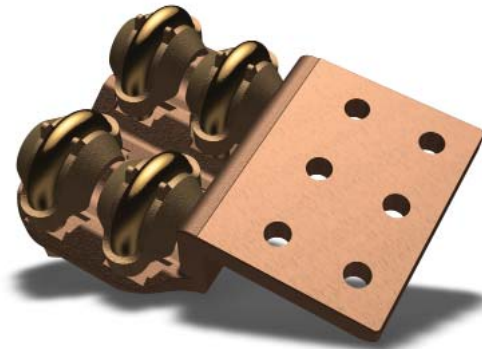

Catalog Number	Fig. #	Copper Stranded Range	L	C	T	W	H
VV2A344N	2	300 kcmil-500 kcmil	5.50	3.50	0.38	5.12	2.62
VV2A34CG1	2		5.75	3.00	0.38	5.12	2.62
VV2A4044N	3	500 kcmil-800 kcmil	9.06	4.00	0.50	5.56	1.75
VV2A46CG1	2	1000 kcmil-1500 kcmil	8.75	3.50	0.56	6.75	4.00

**TYPE VV3A
VARILUG™**

For Use On (3) CABLES BUNDLE TO PAD

Type VV3A has three V elements to secure joint against vibration and flexing. Particularly recommended for use on extra flexible cables. One-wrench installation.

Material: Copper Alloy
Hardware: DURIMUM™ Silicon Bronze Hardware

Notes :

- Plated versions: add the required suffix to the catalog number. -TN for regular tin plating
- Please contact factory for other sizes, combinations and availability
- Items with -90 and -45 have oriented pad, respectively 90° and 45°

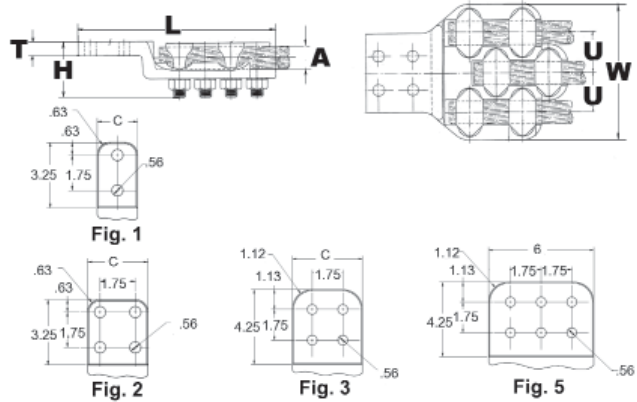

Catalog Number	Fig. #	Copper Stranded Range	T	Pad Angle	L	C	H	U	W
VV3A46CG1	2	1000 kcmil-1500 kcmil	0.84	—	8.75	3.50	3.79	3.52	10.25
VV3A46CG2	2		0.63	—	10.19	5.25	3.93	3.50	10.25
VV3A46CG3	2		1.28	90°	5.84	5.25	6.28	3.50	10.25

**TYPE VF
BOLTED TERMINALS**

For Use On COPPER CABLE TO FLAT

High copper alloy terminal (230kV) for joining a wide range of cable to equipment pads or bar. Particularly suitable for use on extra flexible cable. One-wrench installation.

Material: Copper Alloy
Hardware: DURIMUM™ Silicon Bronze

Notes :

- Plated versions: add the required suffix to the catalog number. -TN for regular tin plating
- Please contact factory for other sizes, combinations and availability

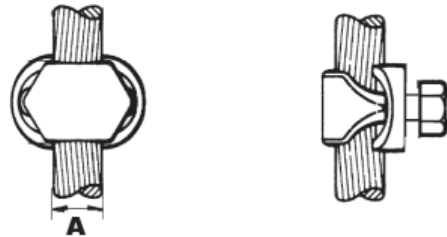

Catalog Number	Cable Range
VF28	1/0 AWG-4/0 AWG
VF30	1/0 AWG-300 kcmil
VF34	300 kcmil-500 kcmil
VF40	500 kcmil-800 kcmil

**TYPE XA
BOLTED EXPANSION
TERMINALS**

For Use On EXPANSION TUBE TO PAD

High copper alloy expansion terminal for tube to flat. Provides for longitudinal movement of tubing. Extra flexible braid carries full load of joint. One-wrench installation.

Material: Copper Alloy

Hardware: DURIMUM™ Silicon Bronze

Notes :

- Plated versions: add the required suffix to the catalog number. -TN for regular tin plating
- Please contact factory for other sizes, combinations and availability
- Installation instructions available upon request

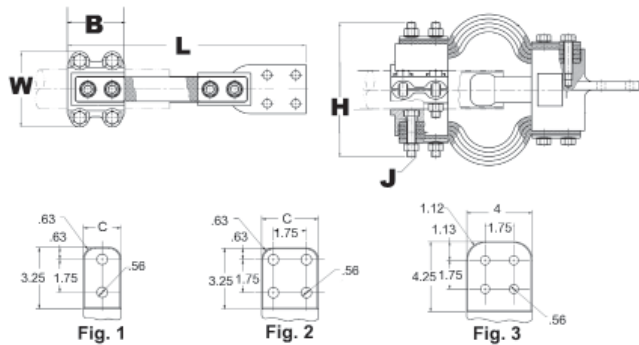

Catalog Number	Fig. #	Copper Pipe (Std)	Copper Pipe (EH)	B	C	J Dia.	L	H	W
XA132N	1	1/2 IPS	N/A	3.00	1.50	3/8	12.00	3.88	3.06
XA142N	1	3/4 IPS		3.00	1.63	3/8	12.00	4.06	3.13
XA144N	2			3.00	3.00	3/8	12.50	4.12	3.12
XA152N	1	1 IPS		3.00	1.88	3/8	12.75	4.31	3.13
XA154N	2			3.00	3.00	3/8	12.75	4.31	3.13
XA162N	1	1 1/4 IPS		3.50	2.25	1/2	14.50	5.81	4.31
XA164N	2			3.50	3.00	1/2	14.75	5.81	4.31
XA172N	1	1 1/2 IPS		3.50	2.50	1/2	15.00	6.06	4.31
XA174N	2			3.50	3.00	1/2	15.25	6.06	4.31
XA184N	2	2 IPS		3.50	3.00	1/2	15.25	7.00	4.62
XA194N	2	2 1/2 IPS		4.00	3.75	1/2	16.13	7.50	5.25
XA204N	2	3 IPS		4.00	4.38	5/8	16.69	7.94	6.50
XA214N	2	3 1/2 IPS		4.00	4.75	5/8	16.94	8.25	6.81
XA224N	2	4 IPS		4.00	5.25	5/8	17.00	9.44	7.44
XA574N	2	N/A		1 1/2 IPS	3.50	3.00	1/2	14.38	6.44
XA594N	2		2 1/2 IPS	4.00	3.75	1/2	14.75	9.56	5.25

TYPE NFXR BOLTED TERMINALS

For Use On PIPE OR CABLE TO FLAT

One of the most versatile products available.
Can be bolted to a four hole NEMA drilled pad.
Rated for 230kV.

Material: Copper Alloy
Hardware: DURIUUM™ Silicon Bronze

Notes :

- Plated versions: add the required suffix to the catalog number. -TN for regular tin plating
- Please contact factory for other sizes, combinations and availability

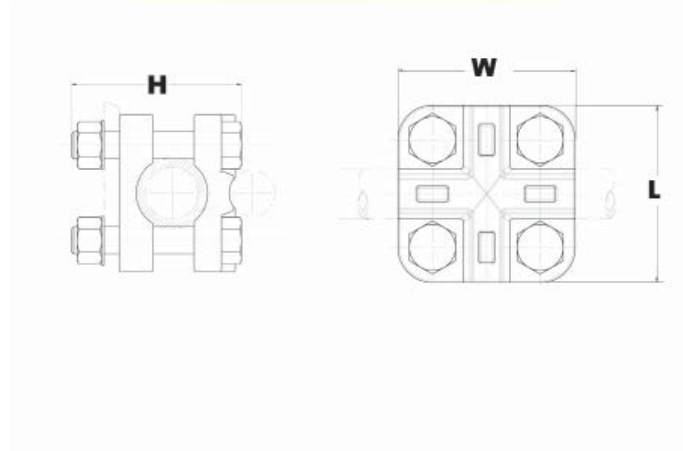

Catalog Number	Copper Cable	Copper Pipe (Std or EH)	H	L	W
NFXR15	1/0 -1250 kcmil	1/4 IPS-1 IPS	3.11	2.88	2.88
NFXR15CG20	1/0 -1250 kcmil		3.11	2.88	2.88
NFXR15CG24	1/0 -1250 kcmil		3.61	2.88	2.88
NFXR15CG7	1/0 -1250 kcmil		3.36	2.88	2.88
NFXR15HQ	1/0 -1250 kcmil		3.86	3.86	2.88

TYPE NBXR BOLTED TERMINALS

For Use On COPPER PIPE OR CABLE TO PAD

One of the most versatile products available. Can be used in Terminal or Tap configuration with a large variety of cable and pipes.

Material: Copper Alloy
Hardware: DURIMUM™ Silicon Bronze

Notes :

- Plated versions: add the required suffix to the catalog number. -TN for regular tin plating
- Please contact factory for other sizes, combinations and availability

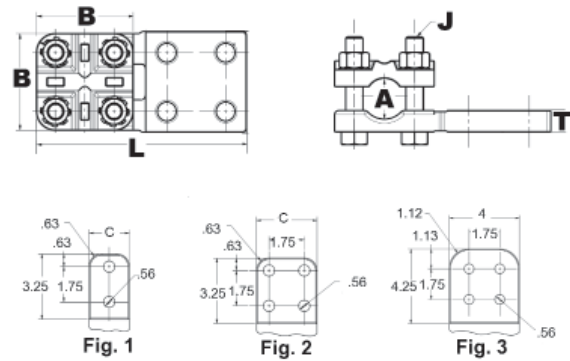

Catalog Number	Fig. #	Stranded Copper Cable	Copper Pipe (Std or EH)	B	T	L	C	J Dia.
NBXR1534NHQ	2	1/0 AWG-1250 kcmil	1/4 IPS -1 IPS	2.88	0.62	6.25	3.00	1/2
NBXR1544NHQ	3					7.19	4.00	
NBXR15CG1	2					6.25	3.00	

TYPE NNBXR COUPLERS / T-CONNECTORS

For Use On PIPE OR CABLE TO PAD

One of the most versatile products available. Can be used in Terminal or Tap configurations and also be bolted to a 4 hole NEMA drilling.

Material: Copper Alloy
Hardware: DURIMUM™ Silicon Bronze

Notes :

- Plated versions: add the required suffix to the catalog number. -TN for regular tin plating
- Please contact factory for other sizes, combinations and availability

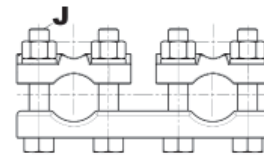
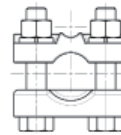
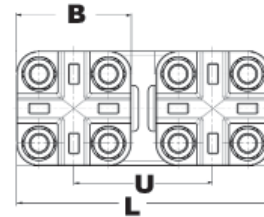

Catalog Number	Stranded Copper Cable	Copper Pipe (Std or EH)	B	L	J Dia.	U
NNBXR1515	1/0 -1250 kcmil	1/4 IPS-1 IPS	2.88	6.38	1/2	3.50

Table of Contents - Copper Couplers

	Type NS Straight Pipe to Pipe	C-23
	Type NS Straight Cable to Cable	C-24
	Type NL Angled Pipe to Pipe	C-25
	Type VP Parallel Cable to Cable	C-27
	Type NR Straight Pipe to Pipe Reducer	C-28
	Type NE Straight Pipe to Cable	C-29
	Type NVVE Straight Pipe to Cable	C-30
	Type NER Straight Pipe to Cable	C-31
	Type NNER Straight Pipe to Cable	C-32
	Type NN2ER Straight Pipe to Cable Bundle	C-33
	Type VR Straight Cable to Cable	C-34
	Type VVR Straight Cable to Cable	C-35
	Type NNBXR Straight Pipe or Cable	C-36

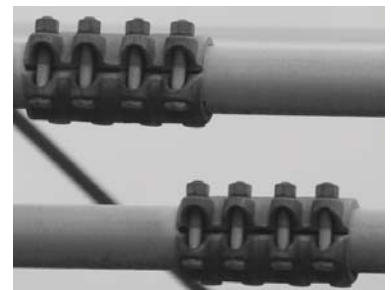
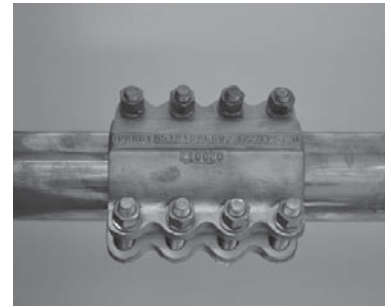
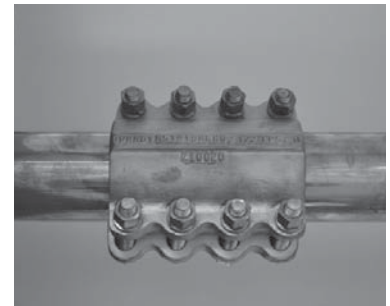

Table of Contents - Copper Couplers (continued)



Type XP Expansion Pipe to Pipe
with Guide

C-37



Type XPL Expansion Pipe to Pipe
without Guide

C-38



Type XHP Expansion Bus Pipe to Pipe

C-39

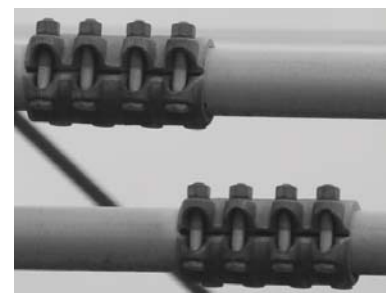
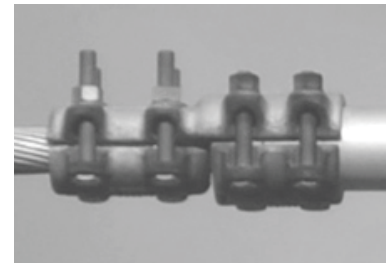

TYPE NS COUPLERS

For Use On STRAIGHT TUBE TO TUBE

High copper alloy coupler for joining equal sizes of tube end to end. Slots between bolts provide independent high pressure areas of contact. One-wrench installation.

Material: Copper Alloy
Hardware: DURIUM™ Silicon Bronze

Notes :

- Plated versions: add the required suffix to the catalog number. -TN for regular tin plating
- - W for extra thick tin plating (including hardware)
- Items with -HC suffix have hex head bolts; items without the suffix can be either hex head or oval shank head. Both head styles are one wrench installation and offer the same clamping force and functionalities.

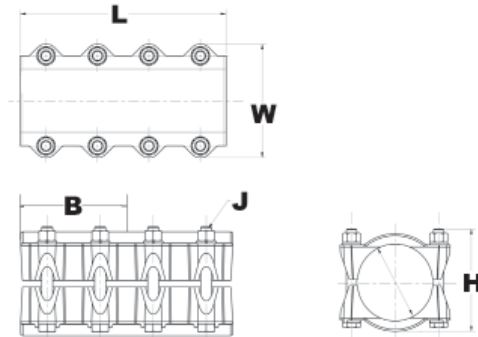

Catalog Number	Copper Conductor	B	J Dia.	L	H	W
NS1212	3/8 IPS	1.50	3/8	3.00	1.44	1.94
NS1313	1/2 IPS	1.63	3/8	3.25	1.69	2.25
NS14148HC	3/4 IPS	2.69	1/2	5.75	2.32	2.81
NS1414HC		2.69	3/8	5.38	2.32	2.81
NS1515	1 IPS	2.13	3/8	4.25	2.13	2.75
NS1515HC		2.69	1/2	5.62	2.32	3.25
NS1515HCHQ		2.69	1/2	5.63	2.36	3.22
NS1616HC	1 1/4 IPS	2.69	1/2	5.75	2.57	3.50
NS1717	1 1/2 IPS	2.88	1/2	5.75	2.75	3.94
NS1717HC		2.69	1/2	5.75	2.81	3.94
NS1717HCHQ		2.69	1/2	5.75	2.61	3.94
NS1818	2 IPS	2.88	1/2	5.75	3.31	4.63
NS1818CG2		2.69	1/2	5.36	3.06	4.62
NS1818HC		2.69	1/2	5.75	3.31	4.62
NS1919	2 1/2 IPS	2.88	1/2	5.75	3.88	5.25
NS1919HC		2.69	1/2	5.75	3.96	5.25
NS1919HCHQ		2.69	1/2	5.75	3.56	5.18
NS2020	3 IPS	3.63	5/8	7.25	4.63	6.19
NS2020HC		3.25	5/8	7.25	4.64	6.19
NS2121	3 1/2 IPS	4.00	5/8	8.00	5.19	6.81
NS2121HC		3.25	5/8	7.25	5.20	6.81
NS2222	4 IPS	4.25	5/8	8.50	5.75	7.44
NS2222HC		3.25	5/8	7.25	5.76	7.44

TYPE NS COUPLERS

For Use On STRAIGHT CABLE TO
CABLE

High copper alloy coupler for joining equal sizes of cable end to end. Slots between bolts provide independent high pressure areas of contact. One-wrench installation.

Material: Copper Alloy

Hardware: DURIMUM™ Silicon Bronze

Notes :

- Plated versions: add the required suffix to the catalog number. -TN for regular tin plating
- - W for extra thick tin plating (including hardware)
- Items with -HC suffix have hex head bolts; items without the suffix can be either hex head or oval shank head. Both head styles are one wrench installation and offer the same clamping force and functionalities.

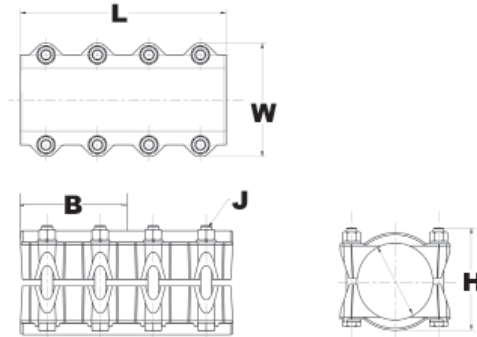

Catalog Number	Copper Conductor	B	J Dia.	L	H	W
NS2626	2/0	1.38	3/8	2.75	1.44	1.81
NS2727	3/0	1.56	3/8	3.13	1.44	1.88
NS2828	4/0	1.56	3/8	3.13	1.44	1.94
NS3434	500	2.13	3/8	4.25	1.69	2.19
NS4444	1000	2.94	1/2	5.88	2.31	3.00
NS4545	1250	2.94	1/2	5.88	2.38	3.25
NS4848	2000	2.94	1/2	5.88	2.75	3.75

**TYPE NL
COUPLERS**

For Use On ANGLED TUBE TO TUBE

High copper alloy coupler for joining equal sizes of tube at various angles. Slots between bolts provide independent high pressure areas of contact. One-wrench installation.

Material: Copper Alloy
Hardware: DURIMUM™ Silicon Bronze

Notes :

- Plated versions: add the required suffix to the catalog number. -TN for regular tin plating
- Items with -HC suffix have hex head bolts; items without the suffix can be either hex head or oval shank head. Both head styles are one wrench installation and offer the same clamping force and functionalities.
- Please contact factory for other sizes, combinations and availability
- One-wrench installation.

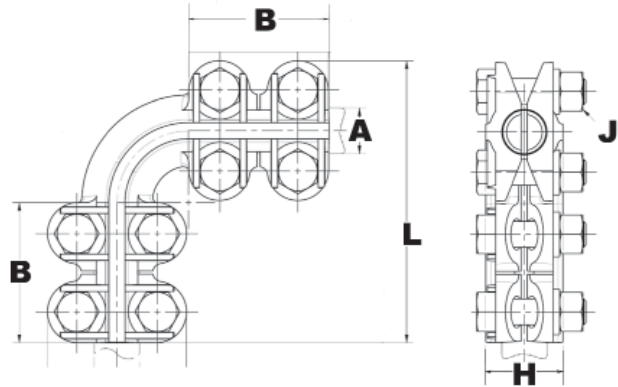

Catalog Number	A-Copper Conductor	B	J Dia.	Angle	L	H
NL1313HC	1/2 IPS	2.69	1/2	90°	5.41	2.32
NL1414	3/4 IPS	1.63	3/8	90°	4.00	1.94
NL14148HC		2.69	1/2	90°	5.40	2.32
NL1515	1 IPS	2.13	3/8	90°	4.75	2.13
NL151545		2.13		45°	5.31	2.13
NL151545HC		2.69	45°	6.75	2.32	
NL1515HC		2.69	90°	5.75	2.32	
NL1616	1 1/4 IPS	2.75	1/2	90°	6.00	2.63
NL161645		2.75		45°	6.81	2.63
NL1717	1 1/2 IPS	2.88		90°	6.63	2.75
NL171745		2.88		45°	7.31	2.75
NL171745HC		3.00		45°	7.31	2.81
NL1717HC		2.69		90°	6.62	2.81
NL1818	2 IPS	2.88		90°	7.19	3.31
NL181845		2.88		45°	7.45	3.31
NL181845HC		2.69		45°	7.62	3.31
NL1818HC		2.69		90°	7.19	3.31
NL1919	2 1/2 IPS	3.00	90°	7.88	3.88	
NL191945		3.00	45°	8.38	3.88	
NL1919HC		2.69	90°	7.75	3.96	

TYPE NL
COUPLERS (Continued)

For Use On ANGLED TUBE TO TUBE



Catalog Number	A-Copper Conductor	B	J Dia.	Angle	L	H
NL202045	3 IPS	3.63	5/8	45°	10.00	4.63
NL2020HC		3.25		90°	9.34	4.64
NL212145	3 1/2 IPS	3.63		45°	10.38	5.19
NL2222	4 IPS	3.63		90°	10.69	5.75
NL222245		3.63		45°	10.69	5.75

**TYPE VP
COUPLERS**

For Use On PARALLEL CABLE TO
CABLE

Parallel coupler for clamping two copper cables. V-bolt clamping elements accommodate large range of cable and are particularly suited for extra flexible cable. With twin V elements for additional joint strength against vibration and flexing.

Material: Copper Alloy
Hardware: DURIMUM™ Silicon Bronze

Notes :

- Plated versions: add the required suffix to the catalog number. -TN for regular tin plating
- Please contact factory for other sizes, combinations and availability
- One-wrench installation.

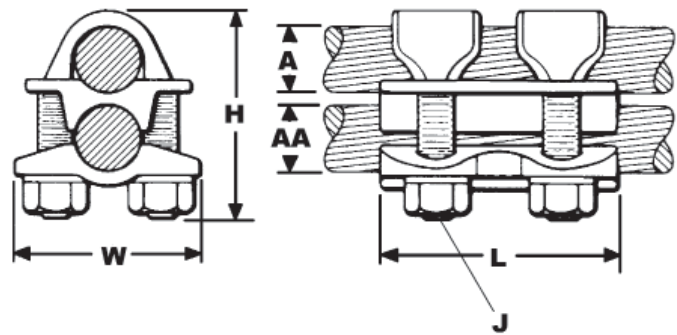

Catalog Number	A - Cable Run Range	AA - Cable Tap Range	J Dia.	H	L	W
VP4634	1000 kcmil-1500 kcmil	300 kcmil-500 kcmil	5/8	5.56	4.16	3.57

TYPE NR COUPLERS

For Use On STRAIGHT TUBE TO TUBE REDUCER

High copper alloy coupler for joining various sizes of tube to tube end to end. Slots between bolts provide independent high pressure areas of contact.

Material: Copper Alloy

Hardware: DURIMUM™ Silicon Bronze

Notes :

- Items with -HC suffix have hex head bolts; items without the suffix can be either hex head or oval shank head. Both head styles are one wrench installation and offer the same clamping force and functionalities.
- Please contact factory for other sizes, combinations and availability

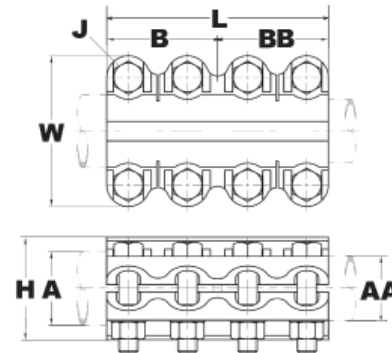

Catalog Number	A - Run Pipe Size	AA - Pipe Size	B	J Dia.	BB	L	H	W
NR1413	3/4 IPS	1/2 IPS	2.00	3/8	2.00	4.31	1.94	2.44
NR1514	1 IPS	3/4 IPS	2.00	3/8	2.00	4.38	2.13	2.75
NR1614HC	1 1/4 IPS	3/4 IPS	2.69	1/2	2.69	6.00	2.56	3.50
NR1716	1 1/2 IPS	1 1/4 IPS	2.69	1/2	2.69	5.81	2.75	3.94
NR1814HC	2 IPS	3/4 IPS	2.69	1/2	2.69	6.12	3.06	4.56
NR1815	2 IPS	1 IPS	2.00	3/8	2.00	4.75	3.19	4.06
NR1817		1 1/2 IPS	2.69	1/2	2.69	5.94	3.25	4.63

TYPE NE COUPLERS

For Use On STRAIGHT TUBE TO
CABLE REDUCER

High copper alloy coupler for joining various sizes of tube cable end to end. One-wrench installation.

Material: Copper Alloy
Hardware: DURIMUM™ Silicon Bronze

Notes :

- Plated versions: add the required suffix to the catalog number. -TN for regular tin plating
- Please contact factory for other sizes, combinations and availability
- One wrench installation.

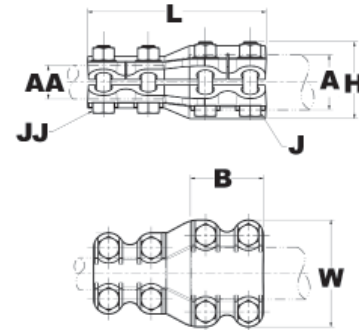

Catalog Number	A - Pipe Size	AA - Cable Size	B	J Dia.	JJ Dia.	L	H	W
NE1328	1/2 IPS	4/0 AWG	2.00	3/8	3/8	4.31	1.69	2.25
NE1426	3/4 IPS	2/0 AWG	1.38	3/8	1/2	3.00	1.94	2.44
NE1428		4/0 AWG	2.00	3/8	1/2	4.50	1.94	2.44
NE1429		250 kcmil	2.00	3/8	1/2	4.50	1.94	2.44
NE1526	1 IPS	2/0 AWG	1.38	3/8	1/2	3.06	2.06	2.69
NE1528		4/0 AWG	2.00	3/8	1/2	4.56	2.06	2.69
NE1534		500 kcmil	2.00	3/8	1/2	4.56	2.06	2.75
NE1544		1000 kcmil	2.00	3/8	1/2	4.62	2.75	2.75
NE1634	1 1/4 IPS	500 kcmil	2.00	3/8	1/2	4.62	2.75	3.06

TYPE NVVE COUPLERS

For Use On STRAIGHT TUBE TO
CABLE

High copper alloy coupler for pipe run, cable tap. DURIMUM™ V-bolt clamping elements accommodate large range of cable and are particularly suited for extra flexible cable. With twin V elements for additional joint strength against vibration and flexing.

Material: Copper Alloy

Hardware: DURIMUM™ Silicon Bronze

Notes :

- Please contact factory for other sizes, combinations and availability

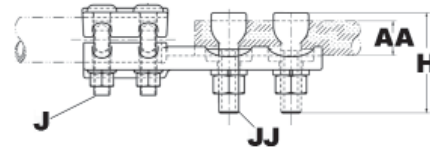
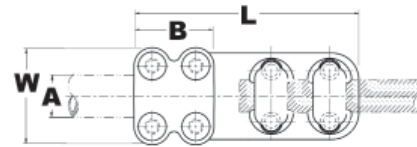

Catalog Number	A Pipe Conductor	AA Cable Conductor	B	J Dia.	JJ Dia.	L	H	W
NVVE1434	3/4 IPS	300 kcmil-500 kcmil	2.00	3/8	1/2	5.75	2.41	2.44
NVVE1844	2 IPS	750 kcmil-1000 kcmil	2.69	1/2	5/8	7.00	3.69	4.62

TYPE NER COUPLERS

For Use On STRAIGHT TUBE TO
CABLE

High copper alloy bolted coupler connector for joining in line a copper tube to cable end to end.

Material: Copper Alloy

Hardware: DURIMUM™ Silicon Bronze

Notes :

- Please contact factory for other sizes, combinations and availability

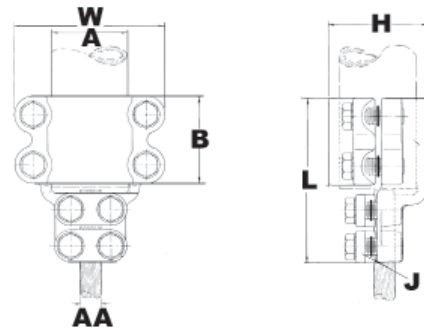

Catalog Number	A Copper Pipe - Run	AA Copper Cable - Tap	B	J Dia.	L	H	W
NER1430	3/4 IPS	1/0 AWG -300 kcmil	2.69	1/2	5.06	1.81	2.81
NER1530	1 IPS	1/0 AWG -300 kcmil	2.69		5.12	2.00	3.19
NER1534		250 kcmil-500 kcmil	2.69		5.12	2.06	3.19
NER1634	1 1/4 IPS	250 kcmil-500 kcmil	2.69		5.12	2.28	3.50
NER1734	1 1/2 IPS	250 kcmil-500 kcmil	2.69		5.12	2.53	3.94
NER1744		750 kcmil-1000 kcmil	2.69		5.12	2.53	3.94
NER1840	2 IPS	500 kcmil-800 kcmil	2.69		5.12	3.06	4.62
NER1844		750 kcmil-1000 kcmil	2.69		5.12	3.06	4.62
NER1944	2 1/2 IPS	750 kcmil-1000 kcmil	2.69		5.19	3.62	5.25

TYPE NNER COUPLERS

For Use On STRAIGHT TUBE TO
CABLE

High copper alloy bolted coupler connector for joining in line a copper tube to a tap cable.

Material: Copper Alloy

Hardware: DURIMUM™ Silicon Bronze

Notes :

- Items with -HC suffix have hex head bolts; items without the suffix can be either hex head or oval shank head. Both head styles are one wrench installation and offer the same clamping force and functionalities.
- Please contact factory for other sizes, combinations and availability

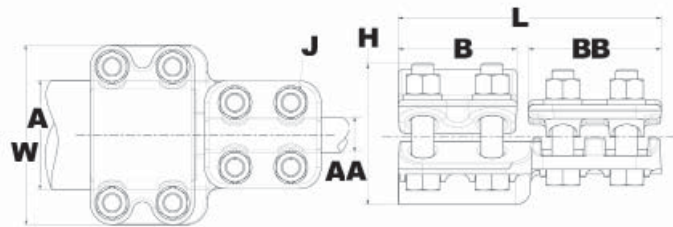
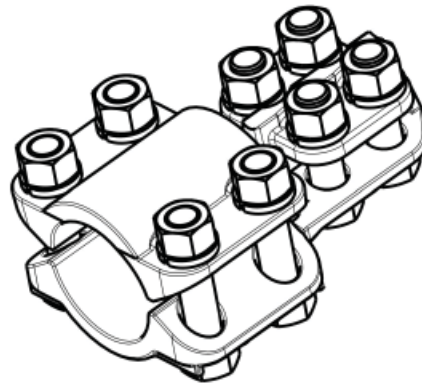

Catalog Number	A Copper Pipe	AA Copper Cable	J Dia.	B	BB	L	H	W
NNER1434HC	3/4 IPS	250 kcmil-500 kcmil	1/2	2.69	3.00	5.94	2.31	2.81
NNER1644HC	1 1/4 IPS	750 kcmil-1000 kcmil	1/2	2.69	3.03	6.20	2.56	3.50
NNER1729HC	1 1/2 IPS	5 AWG-250 kcmil	1/2	2.69	2.62	5.69	2.70	3.82
NNER1840HC	2 IPS	500 kcmil-800 kcmil	1/2	2.69	3.00	5.94	3.19	4.62

**TYPE NN2ER
COUPLERS**

For Use On STRAIGHT TUBE TO (2)
CABLES

High copper alloy bolted coupler connector for joining in line a copper tube to (2) tap cables.

Material: Copper Alloy

Hardware: DURIMUM™ Silicon Bronze

Notes :

- Items with -HC suffix have hex head bolts; items without the suffix can be either hex head or oval shank head. Both head styles are one wrench installation and offer the same clamping force and functionalities.
- Please contact factory for other sizes, combinations and availability
- One wrench installation.

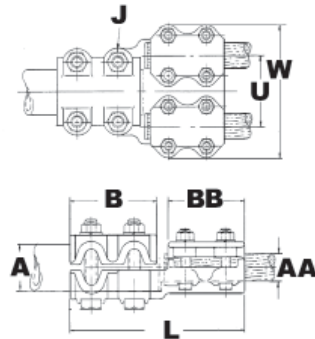

Catalog Number	A Copper Pipe	AA Copper Cable	U	J Dia.	B	BB	L	W
NN2ER1944HC	2 1/2 IPS	750 kcmil-1000 kcmil	1.63	1/2	2.88	3.15	6.25	6.26

TYPE VR COUPLERS

For Use On STRAIGHT CABLE TO
CABLE REDUCER

High copper alloy coupler for pipe cable, cable tap. DURIMUM™ V-bolt clamping elements accommodate large range of cable and are particularly suited for extra flexible cable. One-wrench installation.

Material: Copper Alloy

Hardware: DURIMUM™ Silicon Bronze

Notes :

- Plated versions: add the required suffix to the catalog number. -TN for regular tin plating
- Please contact factory for other sizes, combinations and availability
- One wrench installation.

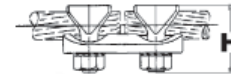
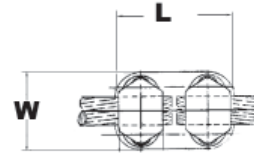
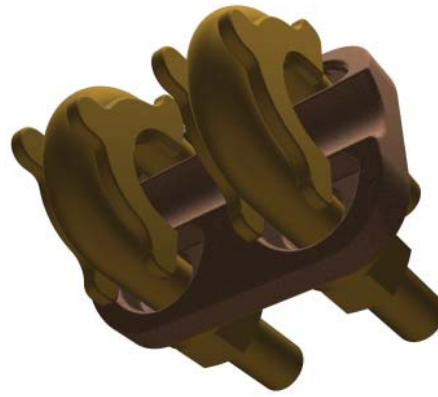

Catalog Number	Cable Run	Solid Run	Cable in-line Tap	Solid in-line Tap	L	H	W	
VR2525	6 AWG-1/0 AWG	6 AWG-1/0 AWG	6 AWG-1/0	6 AWG-1/0 AWG	2.88	1.63	1.19	
VR2825	1/0 AWG-4/0 AWG	2/0 AWG-4/0 AWG	6 AWG-1/0	6 AWG-1/0 AWG	2.78	1.63	1.69	
VR2828			1/0 -4/0 AWG	2/0 AWG-4/0 AWG	2.50	1.63	1.69	
VR3030	1/0 AWG-300 kcmil	N/A	1/0 -300 kcmil	2/0 AWG-4/0 AWG	2.75	1.88	1.94	
VR3428	300 kcmil-500 kcmil		1/0 -4/0 AWG	2/0 AWG-4/0 AWG	2.88	2.31	2.25	
VR3430			1/0 -300 kcmil	2/0 AWG-4/0 AWG	3.00	2.31	2.25	
VR3434			300 kcmil-500 kcmil	N/A	N/A	3.00	2.31	2.24
VR4040	500 kcmil-800 kcmil		500 kcmil-800 kcmil	N/A	N/A	3.75	2.56	2.63
VR4444	750 kcmil-1000 kcmil		750 kcmil-1000 kcmil	N/A	N/A	4.00	2.88	2.88
VR4646	1000 kcmil-1500 kcmil		1000 kcmil-1500 kcmil	N/A	N/A	4.50	3.13	3.25

**TYPE VVR
COUPLERS**

For Use On STRAIGHT CABLE TO
CABLE REDUCER

High copper alloy coupler for pipe cable, cable tap. DURIUM™ V-bolt clamping elements accommodate large range of cable and are particularly suited for extra flexible cable. Twin V elements provide additional resistance against vibration and flexing. One-wrench installation.

Material: Copper Alloy
Hardware: DURIUM™ Silicon Bronze

Notes :

- Plated versions: add the required suffix to the catalog number. -TN for regular tin plating
- Please contact factory for other sizes, combinations and availability

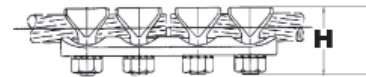
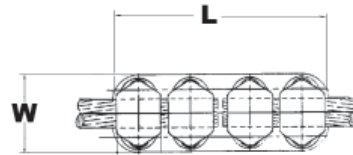
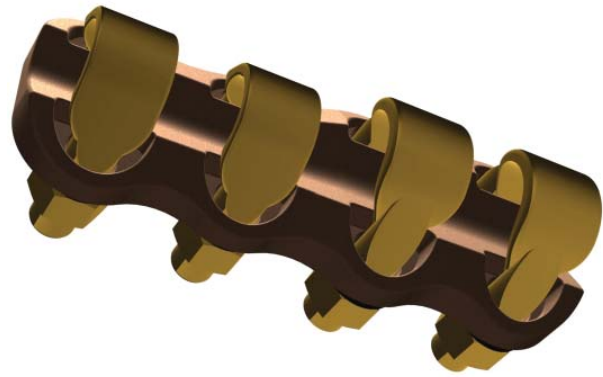

Catalog Number	Cable Run	Cable in-line Tap	L	H	W
VVR3030	1/0 AWG-300 kcmil	1/0 AWG-300 kcmil	5.62	1.84	1.91
VVR4444	750 kcmil-1000 kcmil	750 kcmil-1000 kcmil	8.25	2.84	2.88
VVR4844	1500 kcmil-2000 kcmil		9.25	4.28	3.75
VVR4848		1500 kcmil-2000 kcmil	10.25	4.28	3.75

TYPE NNBXR COUPLERS / T-CONNECTORS

For Use On PIPE OR CABLE TO PAD

One of the most versatile products available. Can be used in Terminal or Tap configurations and also be bolted to a 4 hole NEMA drilling.

Material: Copper Alloy

Hardware: DURIMUM™ Silicon Bronze

Notes :

- Plated versions: add the required suffix to the catalog number. -TN for regular tin plating
- Please contact factory for other sizes, combinations and availability

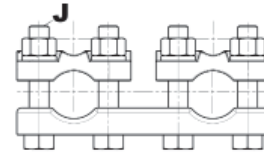
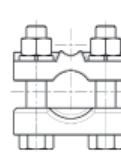
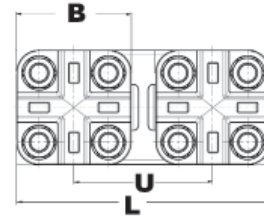

Catalog Number	Stranded Copper Cable	Copper Pipe (Std or EH)	B	L	J Dia.	U
NNBXR1515	1/0 AWG-1250 kcmil	1/4 IPS-1 IPS	2.88	6.38	1/2	3.50

**TYPE XP
EXPANSION COUPLERS**

For Use On EXPANSION TUBE TO TUBE

High alloy copper expansion coupler for joining equal size tube on end. Extra flexible tinned copper braid allows longitudinal movement of the tube. Type XP has alignment guide.

Material: Copper Alloy

Hardware: DURIMUM™ Silicon Bronze

Notes :

- Items with -HC suffix have hex head bolts; items without the suffix can be either hex head or oval shank head. Both head styles are one wrench installation and offer the same clamping force and functionalities.
- Installation instructions available upon request
- For other sizes or configurations, please call factory

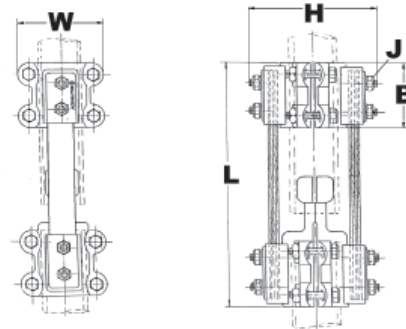

Catalog Number	Copper Pipe Size	Copper EH Pipe Size	B	J Dia.	L	H	W
XP1313	1/2 IPS	—	3.00	3/8	8.75	3.88	3.06
XP1414	3/4 IPS	—		3/8	8.75	4.06	3.13
XP1515	1 IPS	—		3/8	9.50	4.31	3.13
XP1616	1 1/4 IPS	—	3.50	1/2	11.50	5.81	4.31
XP1717	1 1/2 IPS	—		1/2	12.00	6.44	4.31
XP1818	2 IPS	—		1/2	12.00	7.00	4.63
XP1919	2 1/2 IPS	—	4.00	1/2	13.00	8.50	5.25
XP1919HC		—		1/2	13.00	8.50	5.25
XP2020	3 IPS	—	4.00	5/8	13.50	7.75	6.50
XP2121	3 1/2 IPS	—		5/8	13.63	8.00	6.81
XP2222	4 IPS	—		5/8	13.63	9.06	7.44
XP5656	1 1/4 IPS	1 1/4 IPS	3.50	1/2	11.56	5.82	4.24

TYPE XPL EXPANSION COUPLERS

For Use On EXPANSION TUBE TO TUBE (NO GUIDE)

High alloy copper expansion coupler for joining equal size tube on end. Extra flexible tinned copper braid allows longitudinal movement of the tube. The XPL version has no bus guide to keep the straightness.

Material: Copper Alloy

Hardware: DURIMUM™ Silicon Bronze

Notes :

- Items with -HC suffix have hex head bolts; items without the suffix can be either hex head or oval shank head. Both head styles are one wrench installation and offer the same clamping force and functionalities.
- Installation instructions available upon request
- For other sizes or configurations, please call factory

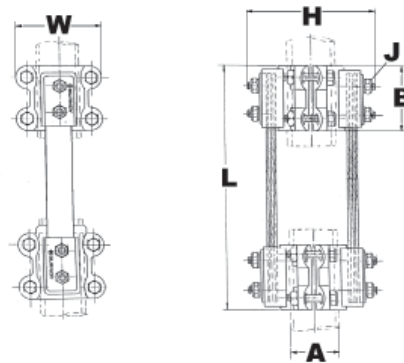

Catalog Number	A-Copper Pipe Size	B	J Dia.	L	H	W
XPL1515	1 IPS	3.00	3/8	9.50	4.31	3.13
XPL1717	1 1/2 IPS	3.50	1/2	12.00	6.44	4.31

TYPE XHP EXPANSION BUS COUPLERS

For Use On EXPANSION BUS
SUPPORT

High alloy copper expansion coupler for joining equal size tube end to end with bus support. Extra flexible tinned copper braid allows longitudinal movement of the tube.

Material: Copper Alloy

Hardware: DURIMUM™ Silicon Bronze

Notes :

- One wrench installation
- Installation instructions available upon request
- For other sizes or configurations, please call factory

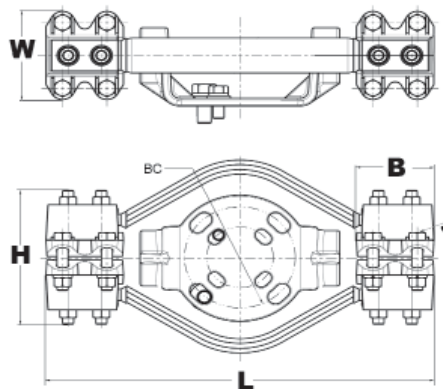

Catalog Number	Copper Pipe Size	EH Copper Pipe Size	BC	J Dia.	B	L	H	W
XHP193	2 1/2 IPS	N/A	3.00	1/2	4.00	17.00	9.19	5.24
XHP573HQ	1 1/2 IPS	1 1/2 IPS	3.00	1/2	3.50	15.25	4.69	6.93

Table of Contents - Copper Bus Supports

	Type UH Copper Pipe	C-43
	Type RHA Copper Pipe	C-44
	Type UHR Copper Cable or Pipe	C-45
	Type RHB Copper Cable	C-46
	Type LH Copper Cable or Pipe	C-47
	Type LHR Copper Cable or Pipe	C-48
	Type LHL Copper Cable or Pipe	C-49
	Type U2HR Copper Cable or Pipe Bundle	C-50
	Type L2H Copper Cable or Pipe Bundle	C-51
	Type NVH Copper	C-52
	Type NSH Copper Pipe	C-53
	Type XHP Expansion Bus Pipe to Pipe	C-54

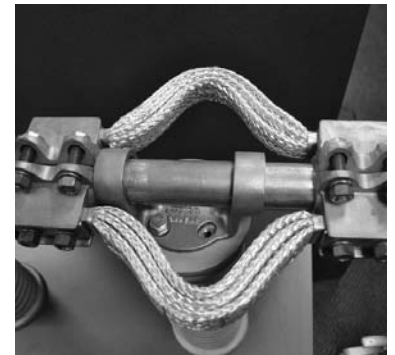

TYPE UH BUS SUPPORTS

For Use On TUBE TO INSULATOR

High copper alloy bus support for mounting tube on a post or pedestal type insulator. Single bolt allows rotation to any angle. Rotate cap 180° for slip or rigid fit. One wrench installation. Supplied with hardware for mounting to cap of insulator. Specify base mounting hardware, if required, by adding suffix “B” to catalog number.

Material: Copper Alloy
Hardware: DURIUUM™ Silicon Bronze

Notes :

- One wrench installation
- Specify base mounting hardware, if required, by adding suffix “-B” to catalog number.
- For other sizes and availability, please contact factory.

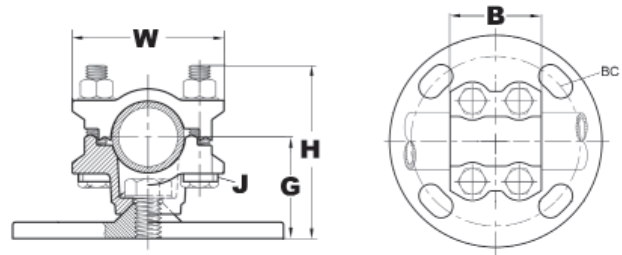

Catalog Number	Copper Pipe Size	BC	G	J Dia.	B	H	W	
UH133	1/2 IPS	3	1.75	3/8	2.50	2.50	2.63	
UH135		5	2.13		2.50	2.88	2.63	
UH143	3/4 IPS	3	2.00		2.50	2.88	2.63	
UH145		5	2.25		2.50	3.13	2.63	
UH153	1 IPS	3	2.00		2.50	3.00	2.88	
UH155		5	2.25		2.50	3.25	2.88	
UH163	1 1/4 IPS	3	2.25	1/2	2.69	3.44	3.50	
UH165		5	2.38		2.69	3.56	3.50	
UH173	1 1/2 IPS	3	2.50		3.00	3.81	3.81	
UH175		5	2.50		3.00	3.81	3.81	
UH183	2 IPS	3	2.75		3.00	4.31	4.63	
UH185		5	2.75		3.00	4.31	4.63	
UH193	2 1/2 IPS	3	3.13		3.00	5.00	5.25	
UH195		5	3.13		3.00	5.00	5.25	
UH203	3 IPS	3	3.63		5/8	3.25	5.81	6.19
UH205		5	3.63			3.25	5.81	6.19
UH213	3 1/2 IPS	3	4.00			3.22	6.50	6.88
UH215		5	4.00			3.22	6.50	6.88
UH223	4 IPS	3	4.50	5.25		7.25	7.38	
UH225		5	4.50	3.25		7.25	7.50	

TYPE RHA BUS SUPPORTS

For Use On TUBE TO INSULATOR

Copper alloy bus support for mounting tube on a post or pedestal type insulator. Adjust cap height with washers for slip or rigid fit. Galvanized steel plate as base. Supplied with hardware for mounting to cap of insulator.

Material: Copper Alloy

Hardware: DURIMUM™ Silicon Bronze

Notes :

- One wrench installation
- Please contact factory for other sizes, combinations and availability
- Specify base mounting hardware, if required, by adding suffix “-B” to catalog number

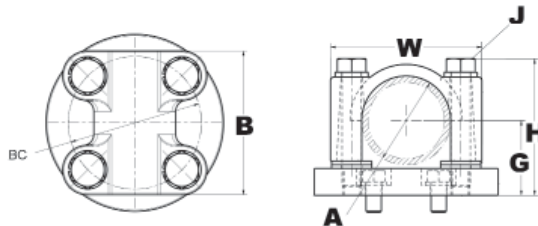

Catalog Number	A - Copper Pipe Size	BC	J Dia.	B	W	H	G
RHA153HQ	1 IPS	3	1/2	3.25	3.25	2.24	0.91
RHA173HQ	1 1/2 IPS	3	5/8	4.94	4.94	3.65	1.83
RHA175HQ		5	5/8		4.94	3.02	1.20
RHA193HQ	2 1/2 IPS	3	5/8		4.94	4.47	2.32
RHA195CG1		5	5/8		4.94	3.81	1.44
RHA195HQ		5	5/8		4.94	3.84	1.69

TYPE UHR BUS SUPPORTS

For Use On CABLE OR TUBE TO
INSULATOR

High copper alloy bus support clamp for mounting a wide range of cable or tube on post or pedestal type insulators. Single bolt allows rotation to any angle. Supplied with hardware for mounting to cap of insulator. Specify base mounting hardware, if required, by adding suffix "-B" to catalog number.

Material: Copper Alloy
Hardware: DURIMUM™ Silicon Bronze

Notes :

- One wrench installation
- Specify base mounting hardware, if required, by adding suffix "-B" to catalog number
- For other sizes and availability, please contact factory

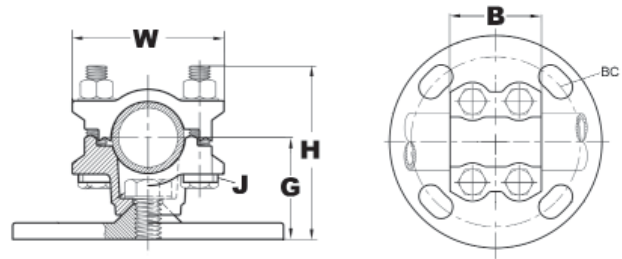

Catalog Number	Copper Stranded Range	Copper Pipe Size	BC	G	J Dia.	B	H	W
UHR133	6 AWG-500 kcmil	1/8 IPS -1/2 IPS	3	1.75	3/8	3.63	3.00	2.25
UHR135			5	2.13	3/8	3.63	3.38	2.25
UHR153	4/0 AWG-1250 kcmil	1/4 IPS -1 IPS	3	2.00	3/8	3.75	3.50	2.75
UHR153SS		1/4 IPS -1 IPS	3	2.00	3/8	3.75	3.50	2.75
UHR155		1/4 IPS -1 IPS	5	2.25	3/8	3.75	3.75	2.75
UHR173	750 kcmil-2500 kcmil	3/4 IPS -1 1/2 IPS	3	2.50	1/2	2.88	4.25	3.94
UHR175			5	2.50	1/2	2.88	4.25	3.94
UHR183	N/A	1 1/4 IPS -2 IPS	3	2.75	1/2	2.81	4.75	4.63
UHR185			5	2.75	1/2	2.81	4.75	4.63

TYPE RHB BUS SUPPORTS

For Use On COPPER CABLE

High copper alloy bus support for mounting a wide range of cable on post or pedestal type insulators. One-wrench installation. Supplied with hardware for mounting to cap of insulator.

Material: Copper Alloy
Hardware: DURIMUM™ Silicon Bronze

Notes :

- Please contact factory for other sizes, combinations and availability

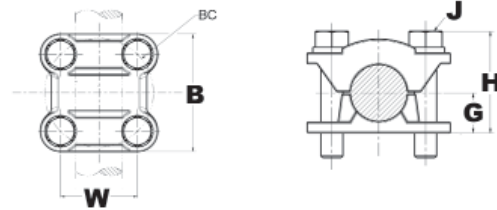

Catalog Number	Copper Stranded Range	BC	G	J Dia.	B	H	W
RHB343HQ	2/0 AWG-500 kcmil	3	0.72	1/2	3.25	1.90	3.25
RHB453	550 kcmil-1250 kcmil		0.91	1/2	3.25	2.28	3.25
RHB453HQ			0.91	1/2	3.25	2.28	3.25
RHB455		5	1.16	5/8	4.91	2.65	4.91
RHB455HQ			1.16	5/8	4.91	2.65	4.91

TYPE LH BUS SUPPORTS

For Use On CABLE OR TUBE TO
INSULATOR

High copper alloy, light duty bus support for mounting a wide range of cable or tube on post or pedestal type insulators. One-wrench installation. Supplied with hardware for mounting to cap of insulator.

Material: Copper Alloy

Hardware: DURIMUM™ Silicon Bronze

Notes :

- One wrench installation
- Specify base mounting hardware, if required, by adding suffix “-B” to catalog number.
- For applications requiring heavier duty product, please see our UH product line.
- For other sizes and availability, please contact factory.

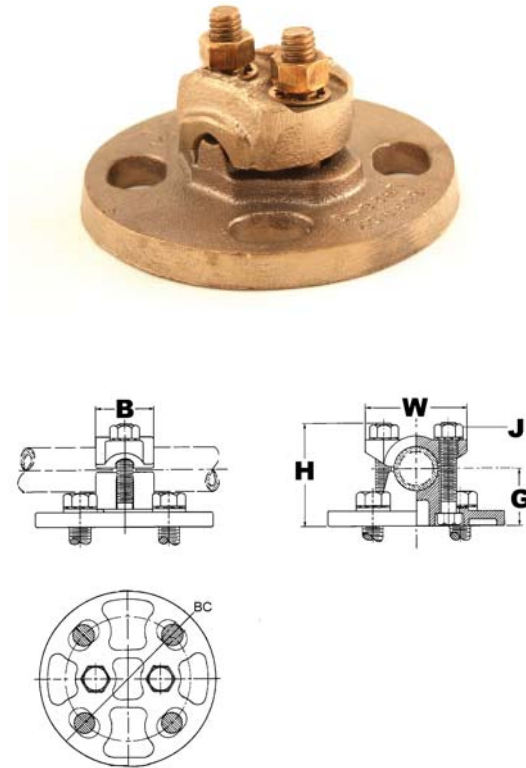

Catalog Number	Tube	Stranded Conductor	BC	G	J Dia.	B	H	W
LH283	N/A	6 AWG-4/0 AWG	3	1.25	3/8	1.69	2.62	4.25
LH343	1/4 IPS-1/2 IPS	2/0 AWG-500 kcmil	3	1.38	3/8	1.38	2.50	4.25
LH453	1/2 IPS-1 IPS	500 kcmil-1250 kcmil	3	1.50	1/2	1.62	3.19	4.44

TYPE LHR BUS SUPPORTS

For Use On CABLE OR TUBE TO
INSULATOR

High copper alloy, bus support for mounting a wide range of cable or tube on post or pedestal type insulators. One-wrench installation. Supplied with hardware for mounting to cap of insulator.

Material: Copper Alloy
Hardware: DURIMUM™ Silicon Bronze

Notes :

- One wrench installation
- Specify base mounting hardware, if required, by adding suffix "-B" to Catalog No.
- For applications requiring heavier duty product, please see our UH product line
- For other sizes and availability, please contact factory

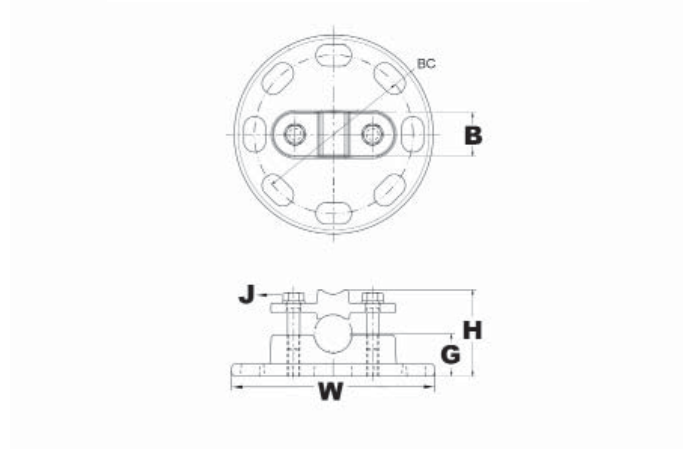

Catalog Number	Tube	Stranded Conductor	BC	G	J Dia.	B	H	W
LHR293	1/8 IPS -1/4 IPS	8 AWG-250 kcmil	3	1.23	3/8	1.00	2.03	4.25
LHR443	1/4 IPS-3/4 IPS	4/0 AWG-1000 kcmil	3	1.31	3/8	1.38	2.67	4.25
LHR445			5	1.33	3/8	1.00	2.51	6.25

**TYPE LHL
BUS SUPPORTS**

For Use On CABLE TO FLAT (1BOLT)

Light Duty Bus support. One bolt mounting configuration to flat surface. No mounting hardware provided.

Material: Copper Alloy
Hardware: DURIMUM™ Silicon Bronze

Notes :

- One wrench installation
- Please contact factory for other sizes, combinations and availability

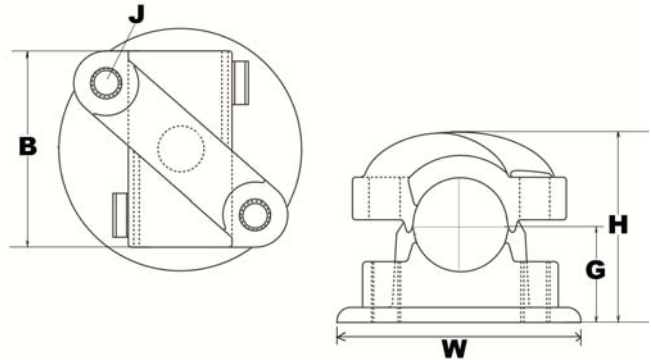

Catalog Number	Tube	Stranded Conductor	G	J Dia.	B	H	W
LHL48L50	1 IPS-1 1/4 IPS	1300 kcmil-2000 kcmil	1.81	1/2	3.75	3.43	4.25

TYPE U2HR BUS SUPPORTS

For Use On (2) CABLES OR (2) TUBES
TO INSULATOR

High copper alloy bus support clamp for mounting a wide range of cable or tube on post or pedestal type insulators. Single bolt allows rotation to any angle. Supplied with hardware for mounting to cap of insulator. Specify base mounting hardware, if required, by adding suffix "-B" to catalog number.

Material: Copper Alloy
Hardware: DURIUM™ Silicon Bronze

Notes :

- One wrench installation
- Specify base mounting hardware, if required, by adding suffix "-B" to catalog number
- For other sizes and availability, please contact factory

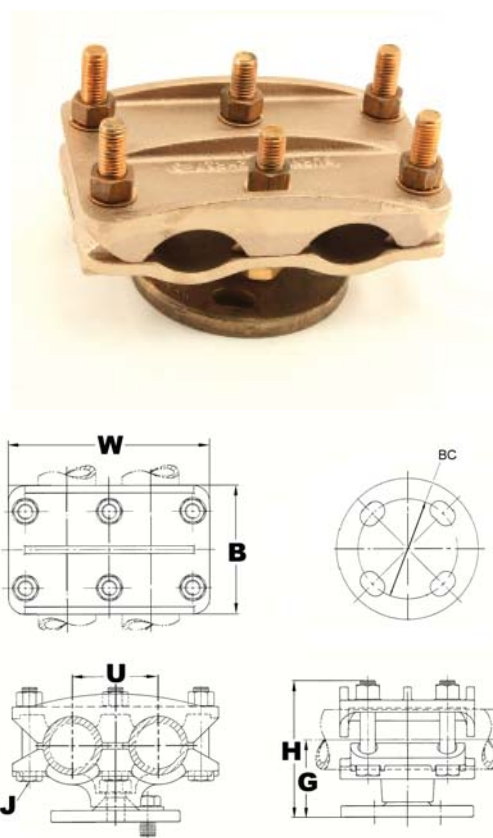

Catalog Number	Copper Stranded Range	Copper Pipe Size	BC	U	B	G	J Dia.	H	W
U2HR153	4/0 AWG-1250 kcmil	1/4 IPS-1 IPS	3	2.00	3.75	2.00	3/8	3.50	4.75
U2HR155	4/0 AWG-1250 kcmil		5	6.00	3.91	2.12	3/8	3.72	6.25
U2HR173	750 kcmil	1 1/2 IPS	3	2.82	4.31	2.50	1/2	4.42	6.75
U2HR175	750 kcmil		5	2.82	4.31	2.70	1/2	4.63	6.75

**TYPE L2H
BUS SUPPORTS**

For Use On (2) CABLES OR (2) TUBES
TO INSULATOR

High copper alloy, bus support for mounting a wide range of (2) cable or tube on post or pedestal type insulators. One-wrench installation. Supplied with hardware for mounting to cap of insulator.

Material: Copper Alloy
Hardware: DURIMUM™ Silicon Bronze

Notes :

- Please contact factory for other sizes, combinations and availability
- Specify base mounting hardware, if required, by adding suffix “-B” to catalog number
- For applications requiring heavier duty product, please see our U2HR product line

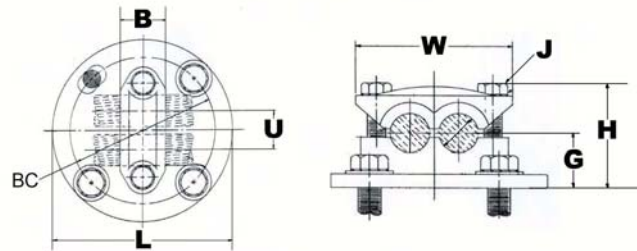

Catalog Number	Copper Stranded Range	Copper Pipe Size	BC	U	B	G	L	J Dia.	H	W
L2H453	1000 kcmil-1250 kcmil	1/2 IPS -1 IPS	3	1.7	1.62	1.50	4.25	1/2	3.00	4.88
L2H455			5	1.7	1.62	1.50	6.25	1/2	3.00	4.88

TYPE NVH BUS SUPPORTS

For Use On VERTICAL TUBE TO
INSULATOR

High copper alloy bus support for mounting vertically a pipe on a post or pedestal type insulator. Adjust height with washers for slip or rigid fit. One wrench installation. Supplied with hardware for mounting to cap of insulator.

Material: Copper Alloy

Hardware: DURIMUM™ Silicon Bronze

Notes :

- One wrench installation
- Specify base mounting hardware, if required, by adding suffix “-B” to catalog number
- For other sizes and availability, please contact factory

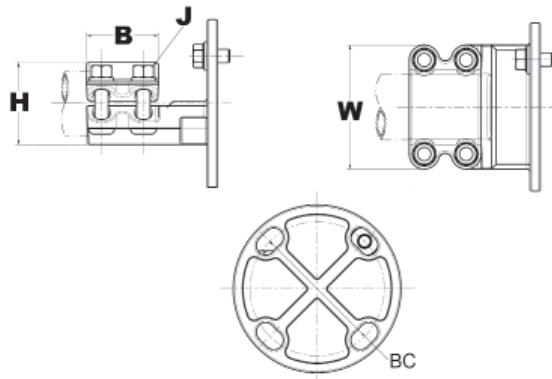
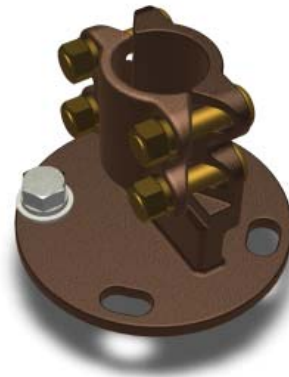

Catalog Number	Copper Pipe Size	BC	J Dia.	B	H	W
NVH175	1 1/2 IPS	5	1/2	2.68	4.88	3.94
NVH183	2 IPS	3	1/2	2.69	4.88	4.62

TYPE NSH BUS SUPPORTS

For Use On RIGID TUBE COUPLER
AND BUS SUPPORT

High copper alloy coupler for joining and supporting equal sizes of tube end to end. Slots between bolts provide independent high pressure areas of contact. One-wrench installation.

Material: Copper Alloy
Hardware: DURIMUM™ Silicon Bronze

Notes :

- One wrench installation
- Please contact factory for other sizes, combinations and availability

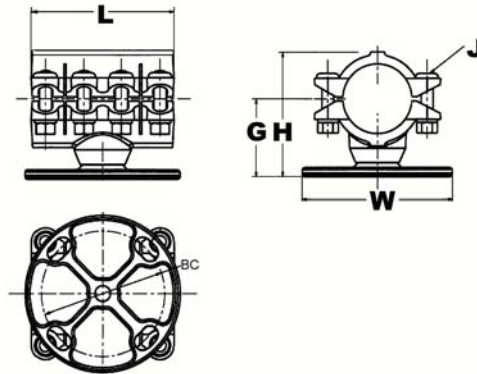

Catalog Number	Copper Pipe Size	BC	G	J Dia.	L	H	W
NSH153	1 IPS	3	2.00	3/8	4.62	2.91	2.88
NSH163	1 1/4 IPS	3	2.25	1/2	5.75	3.47	3.50
NSH183	2 IPS	3	2.75		5.75	4.41	4.62
NSH185		5	2.75		5.75	4.41	4.62
NSH203	3 IPS	3	3.62	5/8	7.25	5.94	6.19
NSH205		5	3.62		7.25	5.94	6.19

TYPE XHP EXPANSION BUS COUPLERS

For Use On EXPANSION BUS
SUPPORT

High alloy copper expansion coupler for joining equal size tube end to end with bus support. Extra flexible tinned copper braid allows longitudinal movement of the tube.

Material: Copper Alloy
Hardware: DURIMUM™ Silicon Bronze

Notes :

- One wrench installation
- Installation instructions available upon request
- For other sizes or configurations, please call factory

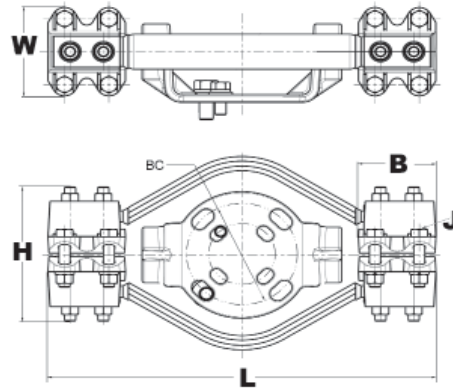
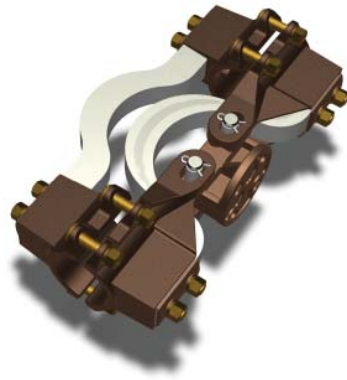

Catalog Number	Copper Pipe Size	EH Copper Pipe Size	BC	J Dia.	B	L	H	W
XHP193	2 1/2 IPS	N/A	3.00	1/2	4.00	17.00	9.19	5.24
XHP573HQ	1 1/2 IPS	1 1/2 IPS	3.00	1/2	3.50	15.25	4.69	6.93

Table of Contents - Copper T / Tap / A-Frames

	Type NT Pipe to Pipe	C-57
	Type NT-HC Pipe to Pipe	C-59
	Type NSNT Pipe to Cable	C-60
	Type NHNT Cable to Cable	C-61
	Type NHNT Pipe to Cable	C-62
	Type N2T Pipe to Cable Bundle	C-63
	Type NB Pipe or Cable to Tap Pad	C-64
	Type NBC Pipe to Tap Pad	C-65
	Type VT Cable to Cable	C-66
	Type VTT Cable to Cable	C-67
	Type VVTT Cable to Cable	C-68
	Type VV21TT Cable Bundle to Cable	C-69
	Type VV22TT Cable Bundle to Cable Bundle	C-70
	Type NVT Pipe to Cable	C-71

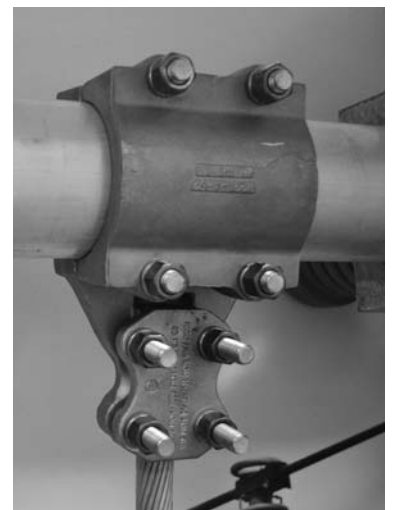

Table of Contents - Copper T / Tap / A-Frames (continued)

	Type NVTT Cable to Cable	C-72
	Type NNHN Cable to Cable	C-73
	Type NYT Cable to Cable Compression	C-74
	Type NY2T Cable to Cable Bundle	C-76
	Type XTL Expansion Pipe to Pipe	C-77
	Type NN2BCAH Cable to Tap Pad	C-78
	Type NFXR Pipe or Cable	C-79
	Type NNBXR Pipe or Cable	C-80
	Type AT Pipe to Tap A-Frame	C-81
	Type NT-75 Angled Pipe to Pipe	C-82



**TYPE NT
T-CONNECTORS**

For Use On TUBE TO TUBE T (6 BOLTS)

High copper alloy T-Connector for tubing run and tap. Slots between bolts provide independent high-pressure areas of contact. One-wrench installation

Material: Copper Alloy
Hardware: DURIMUM™ Silicon Bronze

Notes :

- Plated versions: add the required suffix to the catalog number. -TN for regular tin plating
- Items with -HC suffix have hex head bolts; items without the suffix can be either hex head or oval shank head. Both head styles are one wrench installation and offer the same clamping force and functionalities.
- Please contact factory for other sizes, combinations and availability
- One-wrench installation.

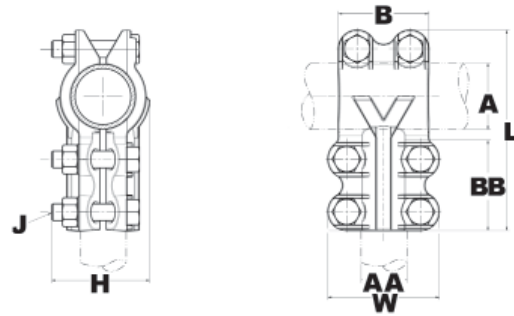

Catalog Number	A Run Copper Pipe	AA Tap Copper Pipe	B	J Dia.	BB	L	H	W
NT1212	3/8 IPS	3/8 IPS	1.38	3/8	1.38	3.38	1.44	2.13
NT1313	1/2 IPS	1/2 IPS	2.00	3/8	2.00	4.13	1.94	2.44
NT1413	3/4 IPS	1/2 IPS	2.00	3/8	2.00	4.13	1.94	2.25
NT1414		3/4 IPS	2.00	3/8	2.00	4.13	1.94	2.44
NT1414HC		3/4 IPS	2.69	1/2	2.69	5.12	2.31	2.88
NT1514	1 IPS	3/4 IPS	2.00	3/8	2.00	4.38	2.13	2.44
NT1515		1 IPS	2.00	3/8	2.00	4.44	2.13	2.75
NT1515HC		1 IPS	2.69	1/2	2.69	5.62	2.31	3.31
NT1515HQ		1 IPS	2.75	1/2	2.69	5.35	2.31	3.19
NT1613	1 1/4 IPS	1/2 IPS	2.00	3/8	2.00	4.75	2.38	2.25
NT1614		3/4 IPS	2.00	3/8	2.00	4.75	2.44	2.44
NT1615		1 IPS	2.00	3/8	2.00	4.75	2.44	2.75
NT1615HC		1 IPS	2.69	1/2	2.69	5.64	2.56	3.31
NT1616		1 1/4 IPS	2.69	1/2	2.69	5.69	2.63	3.50
NT1616HC		1 1/4 IPS	2.69	1/2	2.69	5.64	2.56	3.50
NT1713	1 1/2 IPS	1/2 IPS	2.00	3/8	2.00	5.00	2.56	2.25
NT1714		3/4 IPS	2.00	3/8	2.00	5.06	2.69	2.44
NT1715		1 IPS	2.00	3/8	2.00	5.06	2.69	2.75
NT1715HQ		1 IPS	2.69	1/2	2.69	5.97	2.72	3.31
NT1716		1 1/4 IPS	2.69	1/2	2.69	6.06	2.75	3.50
NT1717		1 1/2 IPS	2.69	1/2	2.69	6.06	2.75	3.94
NT1717HC		1 1/2 IPS	2.69	1/2	2.69	6.06	2.72	3.94
NT1717HQ		1 1/2 IPS	2.69	1/2	2.69	6.06	2.72	3.94
NT1744HQ		N/A	2.69	1/2	2.75	6.06	2.81	3.06

TYPE NT
T-CONNECTORS (Continued)

For Use On TUBE TO TUBE T
(6 BOLTS)



Catalog Number	A Run Copper Pipe	AA Tap Copper Pipe	B	J Dia.	BB	L	H	W
NT1813	2 IPS	1/2 IPS	2.00	3/8	2.00	5.56	3.06	2.25
NT1814		3/4 IPS	2.00	3/8	2.00	5.56	3.12	2.75
NT18148HC		3/4 IPS	2.69	1/2	2.69	7.62	3.06	2.97
NT1815		1 IPS	2.00	3/8	2.00	5.62	3.19	2.75
NT1816		1 1/4 IPS	2.69	1/2	2.69	6.56	2.69	3.50
NT1817		1 1/2 IPS	2.69	1/2	2.69	6.63	3.25	3.94
NT1818		2 IPS	3.06	1/2	2.69	6.69	3.31	4.62
NT18188HC		2 IPS	2.69	1/2	2.69	7.62	3.06	4.62
NT1820		3 IPS	3.50	5/8	3.25	7.44	4.62	6.19
NT1914		2 1/2 IPS	3/4 IPS	2.00	3/8	2.00	6.13	3.69
NT1914HC	3/4 IPS		2.69	1/2	2.69	7.12	3.64	2.88
NT1916	1 1/4 IPS		2.69	1/2	2.69	7.12	3.75	3.50
NT1917	1 1/2 IPS		2.69	1/2	2.69	7.19	3.75	3.94
NT1919	2 1/2 IPS		3.63	1/2	2.69	7.25	3.88	5.25
NT19198HC	2 1/2 IPS		2.69	1/2	2.69	8.25	3.64	5.25
NT1919HC	2 1/2 IPS		2.69	1/2	2.69	7.25	3.64	5.25
NT1919HQ	2 1/2 IPS		3.68	1/2	2.69	7.32	3.64	5.25
NT1944HQ	N/A		2.69	1/2	2.69	7.12	3.99	3.06
NT2014	3 IPS		3/4 IPS	2.00	3/8	2.00	6.75	4.31
NT2016		1 1/4 IPS	2.69	1/2	2.69	7.75	4.38	3.50
NT2017		1 1/2 IPS	2.69	1/2	2.69	7.81	4.44	3.94
NT2018		2 IPS	3.06	1/2	2.69	7.81	4.50	4.63
NT2020		3 IPS	4.31	5/8	3.25	8.63	4.63	6.19
NT2020HC		3 IPS	2.69	1/2	2.69	8.62	4.62	6.19
NT2121	3 1/2 IPS	3 1/2 IPS	4.88	5/8	3.25	9.25	5.19	6.81
NT2220	4 IPS	3 IPS	4.31	5/8	3.25	9.75	5.69	6.19
NT2222		4 IPS	5.44	5/8	3.25	9.81	5.75	7.44

TYPE NT-8HC T-CONNECTORS

For Use On TUBE TO TUBE T (8 BOLTS)

High copper alloy T-Connector for tubing run and tap. Slots between bolts provide independent high-pressure areas of contact. Eight bolt configuration for heavy duty application.

Material: Copper Alloy
Hardware: DURIMUM™ Silicon Bronze

Notes :

- Please contact factory for other sizes, combinations and availability
- Hex Head Bolts
- One-wrench installation.

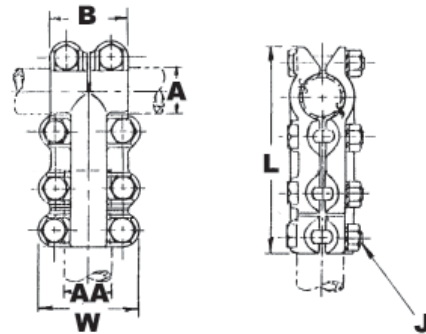

Catalog Number	A Run Copper Pipe	AA Tap Copper Pipe	B	J Dia.	L	W
NT18148HC	2 IPS	3/4 IPS	2.69	1/2	7.62	2.97
NT18188HC		2 IPS	2.69	1/2	7.62	4.62
NT19198HC	2 1/2 IPS	2 1/2 IPS	2.69	1/2	8.25	5.25
NT22188HC	4 IPS	2 IPS	3.05	1/2	9.87	4.50
NT22228HC		4 IPS	5.44	5/8	12.00	7.30

TYPE NSNT T-CONNECTORS

For Use On TUBE OR CABLE TO
CABLE T

High copper alloy reversible T-Connector for joining a wide range of run and tap cables. Connector is designed for one-wrench installation.

“S” standard 3/8in hardware and

“H” heavy duty 1/2in hardware.

Material: Copper Alloy

Hardware: DURIMUM™ Silicon Bronze

Notes :

- Plated versions: add the required suffix to the catalog number. -TN for regular tin plating
- Please contact factory for other sizes, combinations and availability
- One-wrench installation.

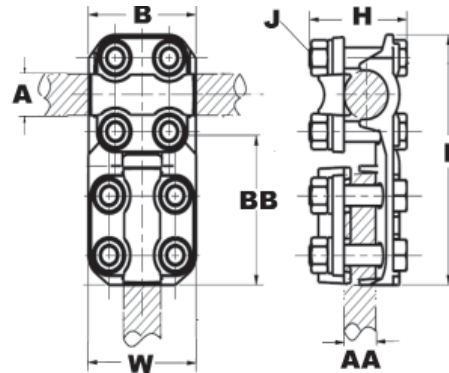

Catalog Number	A Pipe Run	A Cable Run	AA Cable Tap Range	B	J Dia.	BB	L	H	W
NSNT1329	1/2 IPS	N/A	6 AWG-250 kcmil	2.00	3/8	2.38	5.08	2.00	1.96
NSNT1429	3/4 IPS		6 AWG-250 kcmil	2.00	3/8	2.38	5.08	2.00	1.96
NSNT1434			1/0 AWG-500 kcmil	2.00	3/8	2.38	5.08	2.10	2.20
NSNT1529	1 IPS IPS		6 AWG-250 kcmil	2.00	3/8	2.38	5.34	2.00	1.96
NSNT1629	1 1/4 IPS		6 AWG-250 kcmil	2.00	3/8	2.38	5.78	2.37	1.96
NSNT2929	—	6 AWG-250 kcmil	6 AWG-250 kcmil	2.38	3/8	2.38	4.60	1.75	1.96
NSNT3429		1/0 -500 kcmil	6 AWG-250 kcmil	2.38	3/8	2.38	4.84	2.00	1.96
NSNT3434			1/0 AWG-500 kcmil	2.38	3/8	2.38	4.84	2.00	2.20

TYPE NHNT T-CONNECTORS

For Use On CABLE TO CABLE T

High copper alloy reversible T-Connector for joining a wide range of run and tap cables. Connector is designed for one-wrench installation.

Material: Copper Alloy
Hardware: DURIMUM™ Silicon Bronze

Notes :

- Plated versions: add the required suffix to the catalog number. -TN for regular tin plating
- Please contact factory for other sizes, combinations and availability
- One-wrench installation.

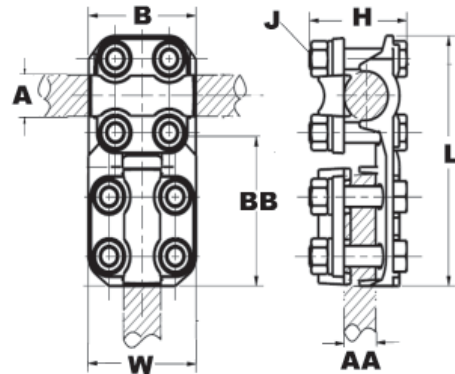

Catalog Number	A - Cable Run	AA - Cable Tap Range	B	J Dia.	BB	L	H	W
NHNT2929	6 AWG-250 kcmil	6 AWG-250 kcmil	2.62	1/2	2.62	5.32	2.07	2.44
NHNT3429	1/0 AWG-500 kcmil	6 AWG-250 kcmil	2.62	1/2	2.62	5.44	2.32	2.44
NHNT4429	4/0 AWG-1000 kcmil	6 AWG-250 kcmil	2.88	1/2	2.62	5.78	2.57	2.44
NHNT4434		1/0 AWG-500 kcmil	2.88	1/2	2.62	5.78	2.57	2.56
NHNT4440		2/0 AWG-800 kcmil	2.88	1/2	2.62	5.78	2.57	2.78
NHNT4444		4/0 AWG-1000 kcmil	2.88	1/2	2.88	6.03	2.57	2.90
NHNT4834	500 kcmil-2000 kcmil	1/0 AWG-500 kcmil	3.25	1/2	2.62	6.26	3.07	2.56
NHNT4840		2/0 AWG-800 kcmil	3.25	1/2	2.62	6.26	3.07	2.78
NHNT4846		1000 kcmil-1500 kcmil	3.25	1/2	3.06	6.76	3.07	3.16
NHNT4848		500 kcmil-2000 kcmil	3.25	1/2	3.25	6.94	3.07	3.38

TYPE NHNT T-CONNECTORS

For Use On TUBE TO CABLE T

High copper alloy reversible T-Connector for joining a wide range of run pipe and tap cables. Connector is designed for one-wrench installation.

Material: Copper Alloy
Hardware: DURIIUM™ Silicon Bronze

Notes :

- Plated versions: add the required suffix to the catalog number. -TN for regular tin plating
- Please contact factory for other sizes, combinations and availability
- One-wrench installation.

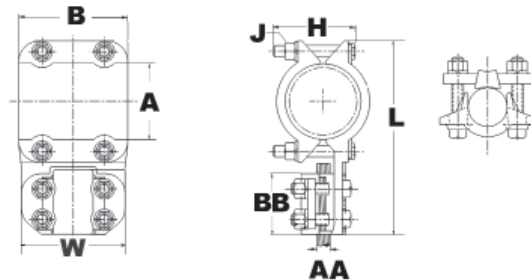
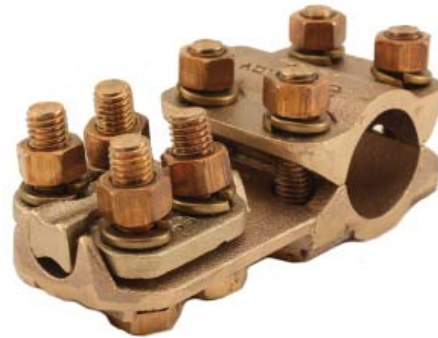

Catalog Number	A Pipe Run	AA Cable Tap Range	B	J Dia.	BB	L	H	W
NHNT1429	3/4 IPS	6 AWG-250 kcmil	2.25	1/2	2.62	5.82	2.32	2.44
NHNT1434		1/0 AWG-500 kcmil	2.25	1/2	2.62	5.82	2.42	2.56
NHNT1529	1 IPS	6 AWG-250 kcmil	2.25	1/2	2.62	5.92	2.57	2.44
NHNT1534		1/0 AWG-500 kcmil	2.25	1/2	2.62	5.92	2.57	2.56
NHNT1540		2/0 AWG-800 kcmil	2.25	1/2	2.62	5.92	2.60	2.78
NHNT1629	1 1/4 IPS	6 AWG-250 kcmil	2.69	1/2	2.62	6.32	2.57	2.44
NHNT1634		1/0 AWG-500 kcmil	2.69	1/2	2.62	6.32	2.60	2.56
NHNT1640		2/0 AWG-800 kcmil	2.69	1/2	2.62	6.32	2.68	2.78
NHNT1644		4/0 AWG-1000 kcmil	2.69	1/2	2.88	6.58	2.69	2.90
NHNT1729	1 1/2 IPS	6 AWG-250 kcmil	2.69	1/2	2.62	6.76	2.70	2.44
NHNT1734		1/0 AWG-500 kcmil	2.69	1/2	2.62	6.76	2.70	2.56
NHNT1740		2/0 AWG-800 kcmil	2.69	1/2	2.62	6.76	2.78	2.78
NHNT1744		4/0 AWG-1000 kcmil	2.69	1/2	2.88	7.02	2.80	2.90
NHNT1829	2 IPS	6 AWG-250 kcmil	2.69	1/2	2.62	7.44	3.06	2.44
NHNT1834		1/0 AWG-500 kcmil	2.69	1/2	2.62	7.44	3.06	2.56
NHNT1840		2/0 AWG-800 kcmil	2.69	1/2	2.62	7.44	3.06	2.78
NHNT1844		4/0 AWG-1000 kcmil	2.69	1/2	2.88	7.70	3.06	2.90
NHNT1846		1000 kcmil-1500 kcmil	2.69	1/2	3.06	7.88	3.23	3.16
NHNT1929	2 1/2 IPS	6 AWG-250 kcmil	2.69	1/2	2.62	8.06	3.64	2.44
NHNT1934		1/0 AWG-500 kcmil	2.69	1/2	2.62	8.06	3.64	2.56
NHNT1940		2/0 AWG-800 kcmil	2.69	1/2	2.62	8.06	3.64	2.78
NHNT1944		4/0 AWG-1000 kcmil	2.69	1/2	2.88	8.32	3.64	2.90
NHNT1946		1000 kcmil-1500 kcmil	2.69	1/2	3.06	8.50	3.64	3.16
NHNT2040	3 IPS	2/0 AWG-800 kcmil	2.69	1/2	2.88	8.69	4.26	2.78
NHNT2044		4/0 AWG-1000 kcmil	2.69	1/2	5.75	8.95	4.26	2.90
NHNT2229	4 IPS	6 AWG-250 kcmil	3.25	1/2	2.63	10.38	4.26	2.50

TYPE N2T T-CONNECTORS

For Use On TUBE OR CABLE TO (2)
CABLES T

High copper alloy bolted type T-Connector for joining copper tube or cable to (2) tap cables.

Material: Copper Alloy

Hardware: DURIMUM™ Silicon Bronze

Notes :

- One wrench installation
- Plated versions: add -TN for regular tin plating, -W for extra thick tin plating (incl. hardware).
- Contact factory for other variations and availability.

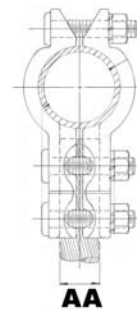
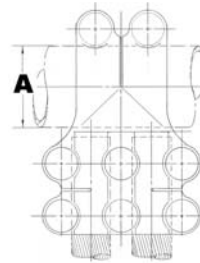
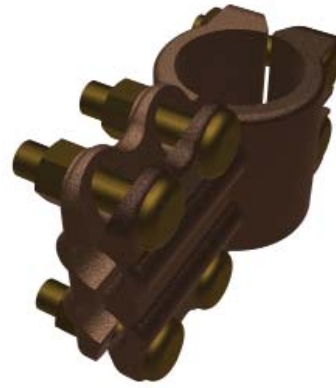

Catalog Number	A - Run Copper Pipe	A - Run Copper Cable	AA - Tap Cable	
N2T1534	1 IPS	N/A	500 kcmil	
N2T1634	1 1/4 IPS		500 kcmil	
N2T1644			1000 kcmil	
N2T1734	1 1/2 IPS		500 kcmil	
N2T1934	2 1/2 IPS		500 kcmil	
N2T1944			1000 kcmil	
N2T2039			750 kcmil	
N2T2044	3 IPS		1000 kcmil	
N2T3434CG1	N/A		500 kcmil	500 kcmil
N2T4434			1000 kcmil	500 kcmil

TYPE NB T-CONNECTORS

For Use On TUBE OR CABLE TO PAD
T

High copper alloy bolted type T-Connector terminal for pipe to tap pad . Pad drilling conforms to NEMA standards. Pad is offset versus conductor centerline.

Material: Copper Alloy
Hardware: DURIMUM™ Silicon Bronze

Notes :

- Plated versions: add the required suffix to the catalog number. -TN for regular tin plating
- Please contact factory for other sizes, combinations and availability
- One-wrench installation.

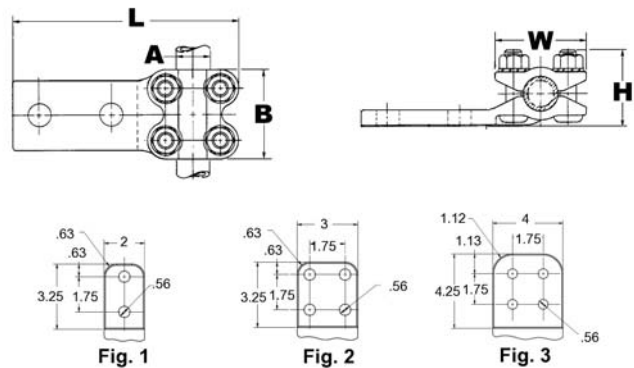

Catalog Number	Fig. #	Copper Pipe (Std or EH)	Copper Cable	L	W	H	B
NB144N	2	3/4 IPS	N/A	5.75	2.44	2.00	2.00
NB152N	1	1 IPS		6.00	2.66	2.12	2.00
NB164NCG1	2	1 1/4 IPS		7.00	3.5	2.62	2.69
NB342N	1	N/A	500 kcmil	5.44	2.19	1.74	2.31
NB344N	2			5.44	2.19	1.74	2.31

**TYPE NBC
T-CONNECTORS**

For Use On TUBE OR CABLE TO TAP PAD

High copper alloy bolted type T-Connector terminal for pipe to tap pad. Pad drilling conforms to NEMA standards. Pad is in-line to the conductor centerline.

Material: Copper Alloy
Hardware: DURIMUM™ - Silicon Bronze Hardware

Notes :

- Plated versions: add the required suffix to the catalog number. -TN for regular tin plating
- Please contact factory for other sizes, combinations and availability
- One-wrench installation.

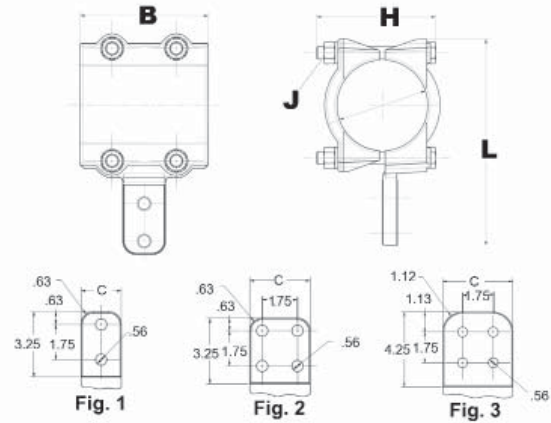
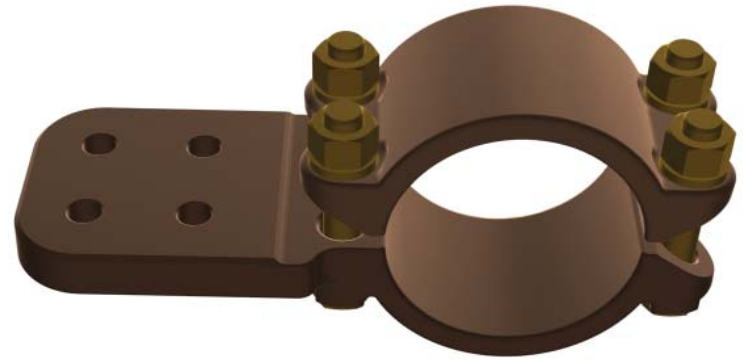

Catalog Number	Fig. #	Copper Pipe (Std or EH)	B	J Dia.	C	L	H
NBC142N	1	3/4 IPS	2.00	3/8	1.62	5.75	1.92
NBC144N	3			3/8	3.00	5.75	1.92
NBC152N	1	1 IPS		3/8	1.88	6.06	2.00
NBC1534N	2			3/8	3.00	6.00	2.00
NBC162N	1	1 1/4 IPS	2.69	1/2	2.25	6.81	2.54
NBC172N	2	1 1/2 IPS		1/2	2.50	7.25	2.68
NBC1734N	2			1/2	3.00	7.07	2.68
NBC1744N	3			1/2	4.00	8.20	2.68
NBC182N	1			2 IPS	1/2	2.75	7.88
NBC1834N	2	1/2			3.00	8.82	3.06
NBC1844NHQ	—	2.68	1/2		4.00	8.82	3.06
NBC184N	3	2.69	1/2		3.00	7.88	3.06
NBC204N	3	3 IPS	3.25	5/8	4.38	9.50	4.32
NBC224N	2	4 IPS		5/8	5.25	10.75	5.45

TYPE VT T-CONNECTORS

For Use On Copper Cable to Cable

High copper alloy T-connector for cable run, cable tap. V-bolt clamping elements accommodate large range of cable and are particularly suited for extra flexible cable. One-wrench installation.

Material: Copper Alloy
Hardware: DURIIUM™ Silicon Bronze

Notes :

- Plated versions: add the required suffix to the catalog number. -TN for regular tin plating
- Please contact factory for other sizes, combinations and availability
- One-wrench installation.

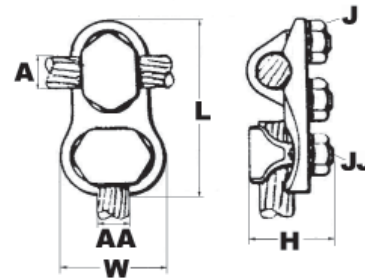

Catalog Number	A - Cable Run Range	AA - Cable Tap Range	J Dia.	JJ Dia.	L	H	W
VT2828	1/0 WAG-4/0 AWG	1/0 AWG-4/0 AWG	3/8	3/8	2.94	.38	0.31
VT3028	1/0 AWG-300 kcmil	1/0 AWG-4/0 AWG	7/16	3/8	3.19	1.88	1.69
VT4034	500 kcmil-800 kcmil	300 kcmil-500 kcmil	9/16	1/2	4.13	2.56	2.25
VT4430	750 kcmil-1000 kcmil	1/0 AWG-300 kcmil	5/8	7/16	4.25	2.88	1.94
VT4434		300 kcmil-500 kcmil	5/8	1/2	4.38	3.34	2.25
VT4440		500 kcmil-800 kcmil	5/8	9/16	4.75	2.88	2.63
VT4444		750 kcmil-1000 kcmil	5/8	5/8	4.88	2.88	2.88
VT4628	1000 kcmil-1500 kcmil	1/0 AWG-4/0 AWG	5/8	3/8	4.50	3.81	1.69
VT4630		1/0 AWG-300 kcmil	5/8	7/16	4.63	3.81	1.94
VT4640		500 kcmil-800 kcmil	5/8	9/16	5.13	3.81	2.63
VT4830	1500 kcmil-2000 kcmil	1/0 AWG-300 kcmil	3/4	7/16	5.13	4.25	1.94
VT4840		500 kcmil-800 kcmil	3/4	9/16	5.63	4.25	2.63
VT4844		750 kcmil-1000 kcmil	3/4	5/8	5.75	4.25	2.88
VT4848		1500 kcmil-2000 kcmil	3/4	3/4	6.25	4.25	3.75

**TYPE VTT
T-CONNECTORS**

For Use On COPPER CABLE TO
CABLE

High copper alloy T-Connector for pipe cable, cable tap. DURIMUM™ V-bolt clamping elements accommodate large range of cable and are particularly suited for extra flexible cable. With twin V elements for additional joint strength against vibration and flexing on tap side

Material: Copper Alloy
Hardware: DURIMUM™ Silicon Bronze

Notes :

- Plated versions: add the required suffix to the catalog number. -TN for regular tin plating
- Please contact factory for other sizes, combinations and availability
- One-wrench installation.
- V-Bolt clamping elements is particularly appropriate for flexible cables

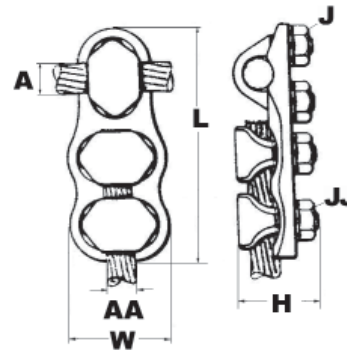

Catalog Number	A Cable Run	AA Cable Tap Range	J Dia.	JJ Dia.	L	H	W
VTT2828	1/0 AWG-4/0 AWG	1/0 AWG-4/0 AWG	3/8	3/8	4.31	1.63	1.69
VTT3030	1/0 AWG-300 kcmil	1/0 AWG-300 kcmil	7/16	7/16	4.69	1.88	1.94
VTT3428	300 kcmil-500 kcmil	1/0 AWG-4/0 AWG	1/2	3/8	4.75	3.34	1.69
VTT3430		1/0 AWG-300 kcmil	1/2	7/16	5.00	3.34	1.94
VTT3434		300 kcmil-500 kcmil	1/2	1/2	5.25	3.34	2.25
VTT4028	500 kcmil-800 kcmil	1/0 AWG-4/0 AWG	9/16	3/8	5.13	2.56	1.69
VTT4034		300 kcmil-500 kcmil	9/16	1/2	5.63	2.56	2.25
VTT4040		500 kcmil-800 kcmil	9/16	9/16	6.38	2.56	2.63
VTT4428	750 kcmil-1000 kcmil	1/0 AWG-4/0 AWG	5/8	3/8	5.38	2.88	1.69
VTT4430		1/0 AWG-300 kcmil	5/8	7/16	5.63	2.88	1.94
VTT4444		750 kcmil-1000 kcmil	5/8	5/8	6.88	2.88	2.88
VTT4630	1000 kcmil-1500 kcmil	1/0 AWG-300 kcmil	5/8	7/16	6.00	3.81	1.94
VTT4646		1000 kcmil-1500 kcmil	5/8	5/8	7.75	3.81	3.25

TYPE VVTT T-CONNECTORS

For Use On CABLE RUN TO CABLE
TAP (TWIN V)

High copper alloy T-Connector for cable run, cable tap. DURIMUM™. Twin V-bolt elements to secure joint against vibration and flexing on both Run and Tap. Particularly recommended for use on extra flexible cable.

Material: Copper Alloy
Hardware: DURIMUM™ Silicon Bronze

Notes :

- Plated versions: add the required suffix to the catalog number. -TN for regular tin plating
- Please contact factory for other sizes, combinations and availability
- One-wrench installation.
- V-bolt clamping element is particularly appropriate for flexible cables

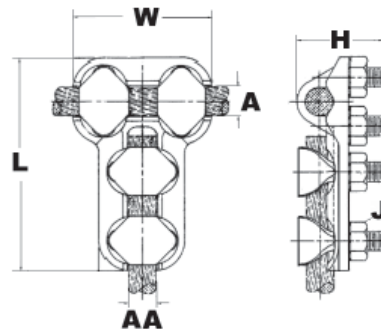
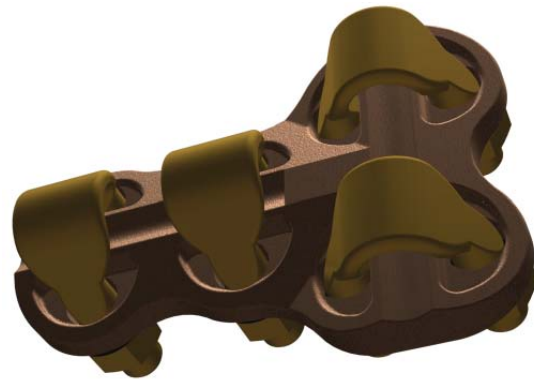

Catalog Number	A Cable Run Range	AA Cable Tap Range	J Dia.	L	H	W
VVTT2828	1/0 AWG-4/0 AWG	1/0 AWG-4/0 AWG	3/8	4.00	1.59	2.62
VVTT3030	1/0 AWG-300 kcmil	1/0 AWG-300 kcmil	7/16	4.50	1.84	1.84
VVTT4040	500 kcmil-800 kcmil	500 kcmil-800 kcmil	1/2	6.06	2.56	3.94
VVTT4444	750 kcmil-1000 kcmil	750 kcmil-1000 kcmil	5/8	6.50	2.84	4.25

**TYPE VV21TT
T-CONNECTORS**

For Use On COPPER CABLE RUN TO
(2) CABLE TAP

Twin V-bolt elements to secure joint against vibration and flexing. Particularly recommended for use on extra flexible cables. One-wrench installation.

Material: Copper Alloy
Hardware: DURIMUM™ Silicon Bronze

Notes :

- Please contact factory for other sizes, combinations and availability

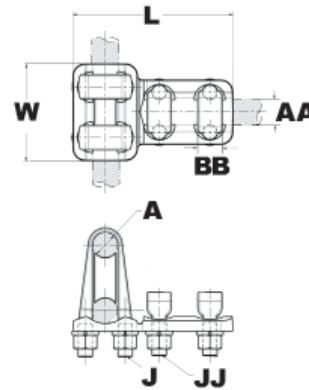

Catalog Number	A Cable Run Range	AA Cable Tap Range	L	W	J Dia.	JJ	BB
VV21TT4040	500 kcmil-800 kcmil	500 kcmil-800 kcmil	6.50	3.94	5/8	5/8	3.50

**TYPE VV22TT
T CONNECTOR**

For Use On (2) CABLE RUN TO (2) CABLE TAP

Twin V-bolt elements to secure joint against vibration and flexing. Particularly recommended for use on extra flexible cables. One-wrench installation.

Material: Copper Alloy
Hardware: DURIMUM™ Silicon Bronze

Notes :

- Plated versions: add the required suffix to the catalog number. -TN for regular tin plating
- Please contact factory for other sizes, combinations and availability
- One-wrench installation.
- V-bolt clamping element is particularly appropriate for flexible cables

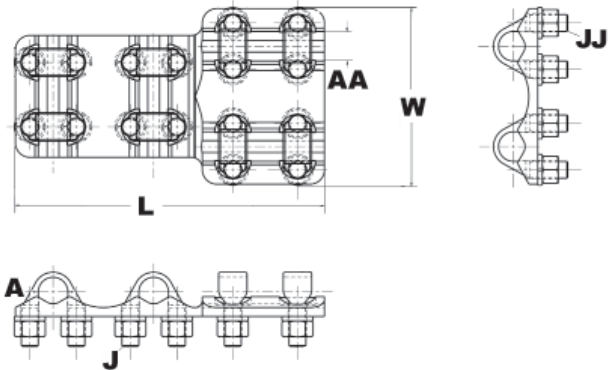
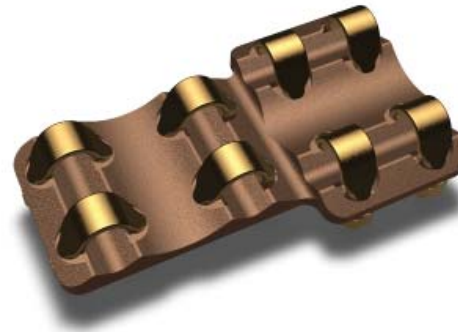

Catalog Number	A Cable Run Range	AA Cable Tap Range	W	L	J Dia.	JJ Dia.
VV22TT4040	500 kcmil-800 kcmil	500 kcmil-800 kcmil	5.81	7.91	5/8	5/8
VV22TT4444	750 kcmil-1000 kcmil	750 kcmil-1000 kcmil	6.31	8.62	5/8	5/8

TYPE NVT T-CONNECTORS

For Use On TUBE TO CABLE

High copper alloy T-Connector for pipe run, cable tap. Regular module for pipe while V-bolt clamping elements accommodate large range of cable and are particularly suited for extra flexible cable. One-wrench installation.

Material: Copper Alloy
Hardware: DURIMUM™ Silicon Bronze

Notes :

- Plated versions: add the required suffix to the catalog number. -TN for regular tin plating
- Please contact factory for other sizes, combinations and availability
- One-wrench installation.
- V-bolt clamping element is particularly appropriate for flexible cables

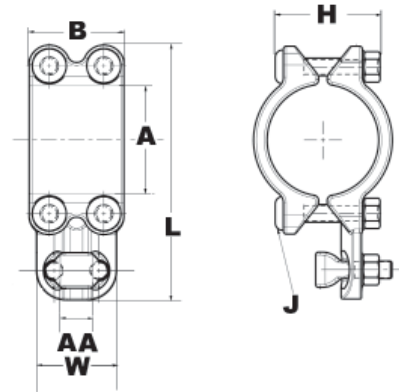

Catalog Number	A Pipe Conductor	AA Cable Tap Conductor	B	J Dia.	L	H	W
NVT1328	1/2 IPS	1/0 AWG-4/0 AWG	2.00	3/8	3.63	1.69	1.69
NVT1330		1/0 AWG-300 kcmil	2.00	3/8	3.75	1.69	1.94
NVT1428	3/4 IPS	1/0 AWG-4/0 AWG	2.00	3/8	3.81	1.94	1.69
NVT1434		300 kcmil-500 kcmil	2.00	3/8	4.13	1.94	2.25
NVT1528	1 IPS	1/0 AWG-4/0 AWG	2.00	3/8	4.13	2.00	1.69
NVT1534		300 kcmil-500 kcmil	2.00	3/8	4.44	2.00	2.25
NVT1728	1 1/2 IPS	1/0 AWG-4/0 AWG	2.00	3/8	4.63	2.44	1.69
NVT1828	2 IPS	1/0 AWG-4/0 AWG	2.00	3/8	5.31	2.94	1.69
NVT1944	2 1/2 IPS	750 kcmil-1000 kcmil	2.69	1/2	7.44	3.56	2.88

TYPE NVTT T-CONNECTORS

For Use On TUBE TO CABLE (TWIN V)

High copper alloy T-Connector for pipe run, cable tap. DURIUUM™ V-bolt clamping elements accommodate large range of cable and are particularly suited for extra flexible cable. With twin V-bolt elements for additional joint strength against vibration and flexing. One-wrench installation.

Material: Copper Alloy
Hardware: DURIUUM™ Silicon Bronze

Notes :

- Please contact factory for other sizes, combinations and availability
- Number of bolts on Run element may vary depending on the run diameter

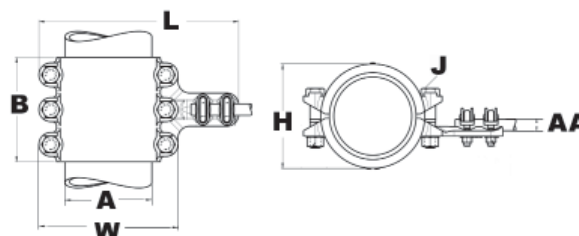

Catalog Number	A Run Pipe Conductor	AA Cable Tap Conductor	B	J Dia.	L	H	W
NVTT1325	1/2 IPS	6 AWG-1/0 AWG	1.38	3/8	5.19	1.69	1.19
NVTT1428	3/4 IPS	1/0 AWG-4/0 AWG	2.00	3/8	5.06	1.94	1.69
NVTT1434		300 kcmil-500 kcmil	2.00	3/8	5.63	1.94	2.25
NVTT1528	1 IPS	1/0 AWG-4/0 AWG	2.00	3/8	5.38	2.00	1.69
NVTT1534		300 kcmil-500 kcmil	2.00	3/8	5.94	2.00	2.25
NVTT1540		500 kcmil-800 kcmil	2.00	3/8	6.25	2.00	2.63
NVTT1630	1 1/4 IPS	1/0 AWG-300 kcmil	2.00	3/8	5.94	2.31	1.94
NVTT1634		300 kcmil-500 kcmil	2.00	3/8	6.25	2.31	2.25
NVTT1828	2 IPS	1/0 AWG-4/0 AWG	2.00	3/8	6.56	2.94	1.69
NVTT1830		1/0 AWG-300 kcmil	2.00	3/8	6.75	2.94	1.94
NVTT1844		750 kcmil-1000 kcmil	2.69	1/2	8.88	3.49	2.88
NVTT1928	2 1/2 IPS	1/0 AWG-4/0 AWG	2.00	3/8	7.13	3.44	1.69
NVTT2028	3 IPS	1/0 AWG-4/0 AWG	2.00	3/8	7.88	4.13	1.69
NVTT2040		500 kcmil-800 kcmil	2.00	3/8	9.38	4.25	2.63
NVTT2044		750 kcmil-1000 kcmil	2.69	1/2	10.00	4.25	2.88

**TYPE NNHN
T-CONNECTORS**

For Use On (2) RUN CABLE TO (2) TAP CABLE

T-Connector to accommodate 2 run cables (copper or aluminum when tin plated) to 2 tap connectors. Tap module is especially appropriate for extra-flexible copper cable but can accommodate regular stranded cables.

Material: Copper Alloy
Hardware: DURIMUM™ Silicon Bronze

Notes :

- Please contact factory for other sizes, combinations and availability
- For applications greater than 2000V consult manufacturer for Voltage stress relief instruction.

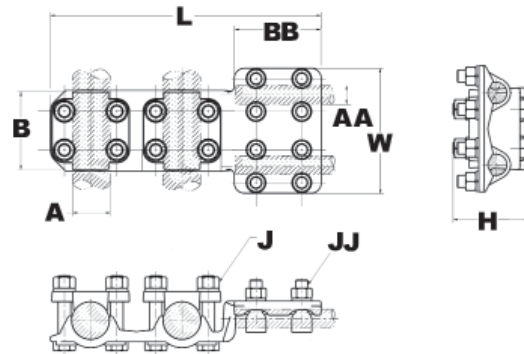
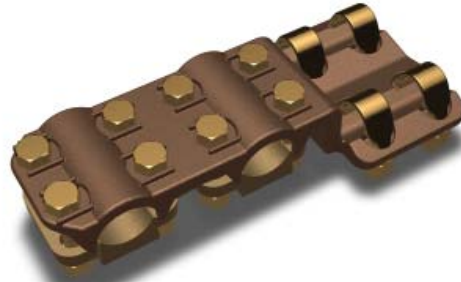

Catalog Number	A Run Cable Conductor	AA Tap Cable Conductor	B	L	BB	W	J Dia.	JJ Dia.	H
NNHN22VVTT48640W	1500 kcmil	500 kcmil-800 kcmil	3.86	13.3	4.25	6.12	5/8	1/2	3.69

TYPE NYT T-CONNECTORS

For Use On BOLTED CABLE TO
COMPRESSION CABLE

A "T" connector designed to provide a clamptype element on the run and a permanent connection on the tap using HYPRESS™ tool. Recommended for use on ring buses or for applications where occasional disconnects from the run conductor are desired without disturbing the tap connection. Tin plated. For proper installation of tap cable, see table below.

Material: Copper Alloy
Hardware: DURIUM Silicon Bronze

Notes :

- Please contact factory for other sizes, combinations and availability
- For applications greater than 2000V consult manufacturer for Voltage stress relief instruction.
- Contact BURNDY for proper tools and dies to use when installing the tap.
- All dimensions are shown for reference only.

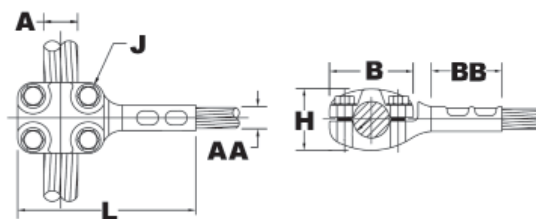
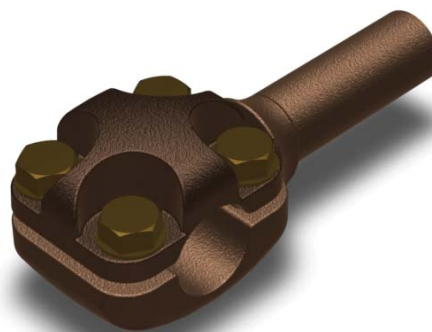

Catalog Number	A Run Cable	AA Tap Cable	B	J Dia.	BB	L	H
NYT2526	1/0 AWG	2/0 AWG	1.38	3/8	1.5	4.13	1.38
NYT2626	2/0 AWG	2/0 AWG	2.00	3/8	1.38	4.25	1.38
NYT2725	3/0 AWG	1/0 AWG	1.50	3/8	1.38	4.13	1.38
NYT2825	4/0 AWG	1/0 AWG	1.50	3/8	1.42	4.09	1.37
NYT2826		2/0 AWG	2.00	3/8	1.38	4.25	1.38
NYT2828		4/0 AWG	2.00	3/8	1.62	1.34	1.34
NYT282C		2/0 AWG	1.50	3/8	1.00	3.81	1.37
NYT2925	250 kcmil	1/0 AWG	1.50	3/8	1.38	4.13	1.50
NYT2929		250 kcmil	2.00	3/8	2.00	4.50	1.50
NYT3125	350 kcmil	1/0 AWG	1.50	3/8	1.38	4.16	1.56
NYT3128		4/0 AWG	2.00	3/8	2.00	4.50	1.50
NYT3131		350 kcmil	2.00	3/8	2.00	4.88	1.63
NYT3426	500 kcmil	2/0 AWG	1.50	3/8	1.50	4.28	1.62
NYT3428		4/0 AWG	2.00	3/8	1.625	4.50	1.625
NYT3429		250 kcmil	2.00	3/8	1.62	4.44	1.62
NYT3431		350 kcmil	2.00	3/8	2.00	5.13	1.63
NYT3434		500 kcmil	2.00	3/8	2.25	5.06	1.63

TYPE NYT
T-CONNECTORS (Continued)

For Use On BOLTED CABLE TO
COMPRESSION CABLE

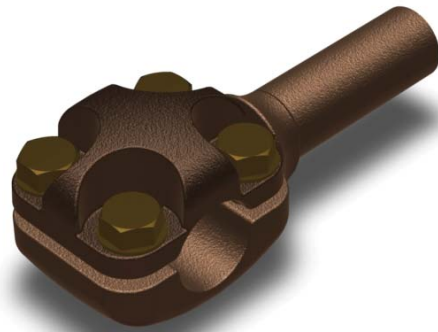

Catalog Number	A Run Cable	AA Tap Cable	B	J Dia.	BB	L	H
NYT3928	750 kcmil	4/0 AWG	2.00	3/8	1.62	4.81	2.02
NYT3929		250 kcmil	2.00	3/8	1.62	4.94	2.05
NYT3931		350 kcmil	2.00	3/8	2.00	5.19	2.00
NYT3934		500 kcmil	2.00	3/8	2.25	5.28	2.00
NYT4429	1000 kcmil	250 kcmil	2.00	3/8	1.62	4.88	2.09
NYT4431		350 kcmil	2.00	3/8	2.00	5.43	2.12
NYT4434		500 kcmil	2.00	3/8	2.25	5.66	2.11
NYT4439		750 kcmil	2.69	3/8	2.00	6.38	2.25
NYT4444		1000 kcmil	2.69	1/2	3.00	6.81	2.25
NYT4628	1500 kcmil	4/0 AWG	2.00	3/8	1.88	5.38	2.47
NYT4634		500 kcmil	2.00	3/8	2.25	6.00	2.41
NYT4639		750 kcmil	2.69	3/8	2.75	6.75	2.75
NYT4644		1000 kcmil	2.69	1/2	3.00	7.03	2.59
NYT4646		1500 kcmil	2.69	1/2	3.19	7.28	2.60
NYT4834	2000 kcmil	500 kcmil	2.00	3/8	2.25	6.00	2.47
NYT4844		1000 kcmil	2.69	1/2	3.00	7.22	2.81
NYT4848		2000 kcmil	2.69	1/2	3.44	7.91	2.81

**TYPE NY2T
T-CONNECTORS**

For Use On CABLE RUN TO (2)
COMPRESSION CABLE TAP

A T-Connector designed to provide a clamp-type element on the run and a permanent connection on the (2) taps using HYPRESS™ tool. Recommended for use on ring buses or for applications where occasional disconnects from the run conductor are desired without disturbing the tap connection. Tin plated.

Material: Copper Alloy
Hardware: DURIMUM - Silicon Bronze Hardware

Notes :

- Please contact factory for other sizes, combinations and availability
- For applications greater than 2000V consult manufacturer for Voltage stress relief instruction.
- Contact BURNDY for proper tools and dies to use when installing the tap.
- All dimensions are shown for reference only.

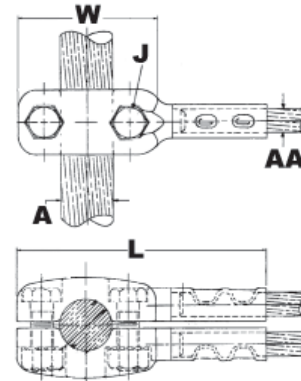

Catalog Number	A Run Cable	AA Tap Cable	W	J Dia.	L
NY2T44G1	1000 kcmil	250 kcmil	1.50	1/2	5.69
NY2T46G1	1500 kcmil	250 kcmil	1.50	1/2	6.00

TYPE XTL T-CONNECTORS

For Use On EXPANSION TUBE TO
TUBE T

High alloy copper expansion T-Connection for joining equal or different size tube. Extra flexible tinned copper braid allows relative movement of the tubes. Type XTL does NOT have alignment guide.

Material: Copper Alloy

Hardware: DURIUUM™ Silicon Bronze

Notes :

- Installation instructions available upon request
- Please contact factory for other sizes, combinations and availability
- Refer XT family if alignment guide is required
- One wrench installation

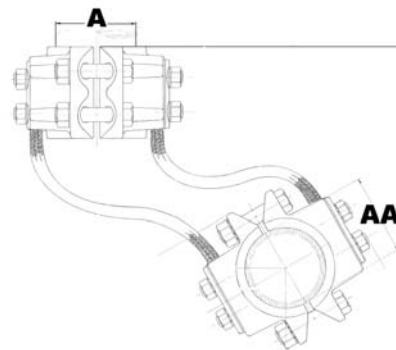
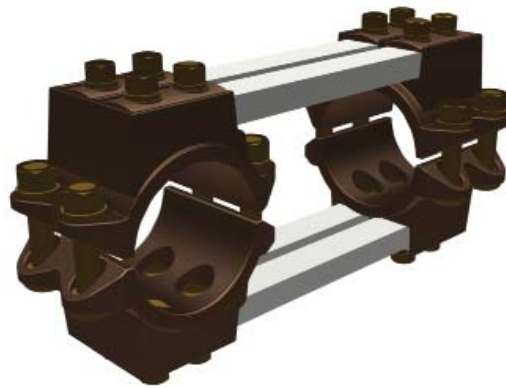

Catalog Number	A Run Conductor	AA Tap Conductor
XTL1717	1 1/2 IPS	1 1/2 IPS

**TYPE NN2BC
T-CONNECTORS**

For Use On (2) CABLES TO TAP PAD

High copper alloy, reversible cap spacer to tap pad for use on a wide range of two copper cable bundles.

Material: Copper Alloy
Hardware: DURIMUM™ Silicon Bronze

Notes :

- Plated versions: add the required suffix to the catalog number. -TN for regular tin plating
- Please contact factory for other sizes, combinations and availability
- One-wrench installation.

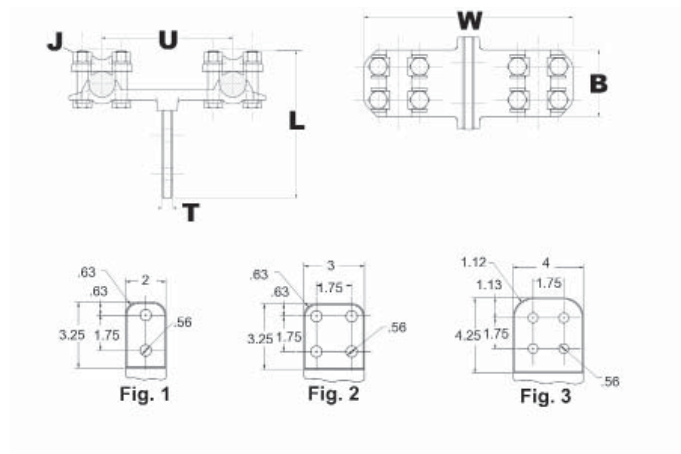
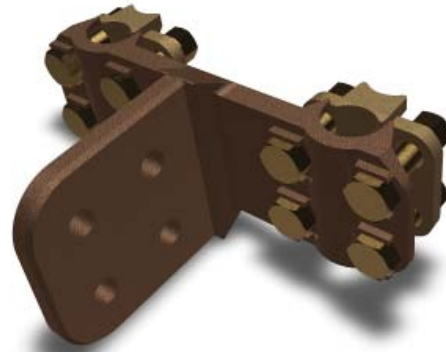

Catalog Number	Fig. #	Copper Conductor	U	B	L	T	J Dia.	W
NN2BCAH4444N	3	4/0 AWG-1000 kcmil	6.00	2.88	6.75	1/2	1/2	9.00

TYPE NFXR BOLTED TERMINALS

For Use On PIPE OR CABLE TO FLAT

One of the most versatile products available. Can be bolted to a four hole NEMA drilled pad. Rated for 230kV.

Material: Copper Alloy
Hardware: DURIUUM™ Silicon Bronze

Notes :

- Plated versions: add the required suffix to the catalog number. -TN for regular tin plating
- Please contact factory for other sizes, combinations and availability

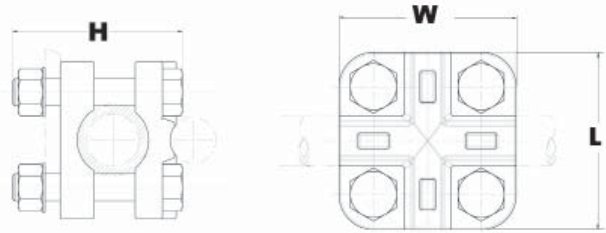

Catalog Number	Copper Cable	Copper Pipe (Std or EH)	H	L	W
NFXR15	1/0 AWG -1250 kcmil	1/4 IPS-1 IPS	3.11	2.88	2.88
NFXR15CG20	1/0 AWG -1250 kcmil		3.11	2.88	2.88
NFXR15CG24	1/0 AWG -1250 kcmil		3.61	2.88	2.88
NFXR15CG7	1/0 AWG -1250 kcmil		3.36	2.88	2.88
NFXR15HQ	1/0 AWG -1250 kcmil		3.86	3.86	2.88

TYPE NNBXR COUPLERS / T-CONNECTORS

For Use On PIPE OR CABLE TO PAD

One of the most versatile products available. Can be used in Terminal or Tap configurations and also be bolted to a 4 hole NEMA drilling.

Material: Copper Alloy

Hardware: DURIMUM™ Silicon Bronze

Notes :

- Plated versions: add the required suffix to the catalog number. -TN for regular tin plating
- Please contact factory for other sizes, combinations and availability

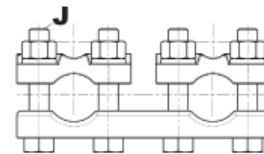
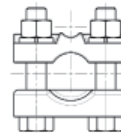
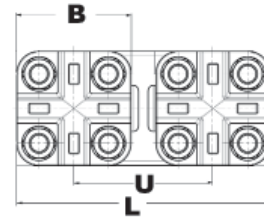

Catalog Number	Stranded Copper Cable	Copper Pipe (Std or EH)	B	L	J Dia.	U
NNBXR1515	1/0 AWG -1250 kcmil	1/4 IPS-1 IPS	2.88	6.38	1/2	3.50

TYPE AT T-CONNECTORS

For Use On A FRAME, TUBE RUN TO
(2) TUBES TAP

Copper alloy bolted type T for joining copper tube to (2) copper tubes forming the top of an A-Frame.

Material: Copper Alloy
Hardware: DURIUM™ Silicon Bronze

Notes :

- One wrench installation
- Please contact factory for other sizes, combinations and availability
- Use NT-75 or NT-80 for the lower fittings of the A-Frame.

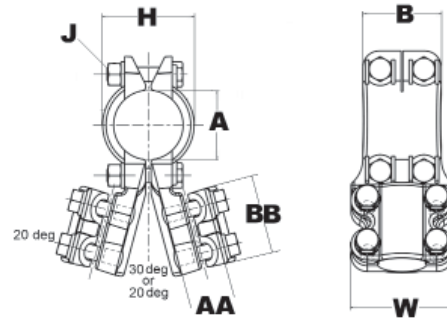
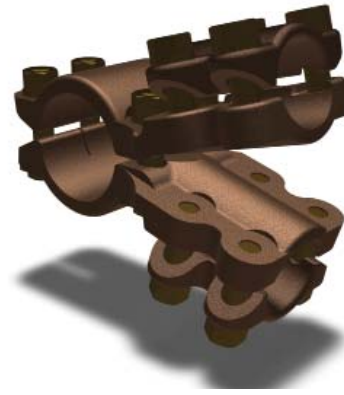

Catalog Number	A Run Copper Pipe	AA Tap Copper Pipe	Angle	B	BB	J Dia.	H	W
AT181530	2 IPS	1 IPS	30°	2.75	2.50	1/2	6.90	3.00
AT181630		1 1/4 IPS	30°	2.19	2.68	1/2	6.38	3.50
AT191730	2 1/2 IPS	1 1/2 IPS	30°	3.59	2.69	1/2	7.42	4.00
AT191830		2 IPS	30°	4.62	2.69	1/2	8.00	4.62

**TYPE NT-75
T-CONNECTORS**

For Use On A FRAME : TUBE TO ANGLED TUBE T

High copper alloy T-Connector for tubing run and tap at 75° or 80° to form the bottom of an A-Frame. Slots between bolts provide independent high-pressure areas of contact. Standard six bolt configuration.

Material: Copper Alloy
Hardware: DURIMUM™ Silicon Bronze

Notes :

- Items with -HC suffix have hex head bolts; items without the suffix can be either hex head or oval shank head. Both head styles are one wrench installation and offer the same clamping force and functionalities.
- Please contact factory for other sizes, combinations and availability
- One-wrench installation.

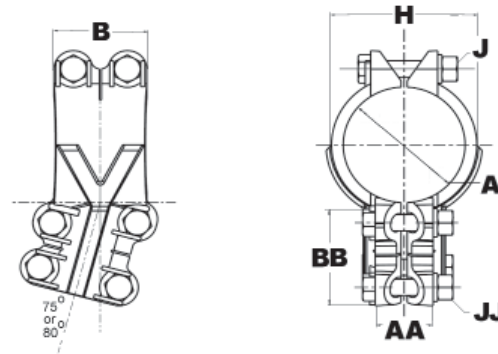

Catalog Number	A - Run Copper Pipe	AA - Tap Copper Pipe	Angle	B	J Dia.	BB	L	H	W
NT181675	2 IPS	1 1/4 IPS	75°	2.69	1/2	2.69	6.44	2.69	3.50
NT201675	3 IPS	1 1/4 IPS	75°	2.69	1/2	2.69	7.81	4.38	3.50

Table of Contents - Copper Stud Connectors

	Type FD Stud to Pad (Contact Surface on CL of Stud)	C-85
	Type NFD Stud to Pad (Contact Surface on CL of Stud)	C-88
	Type FDR Stud to Pad (Flag Position)	C-89
	Type FDA Stud to Pad (Perpendicular to Stud)	C-90
	Type NDR Stud to Cable	C-91
	Type VVD-R Stud to Cable (Flag Position)	C-92
	Type VVD-T Stud to Cable (In-line to Stud)	C-93
	Type N2DR-T Stud to Cable Bundle (Flag Position)	C-94
	Type N11DR-T Stud to Cable Bundle (Flag or In-line)	C-95
	Type VV2D-R Stud to Cable Bundle (Flag or In-line)	C-96
	Type VV2D-T Stud to Cable Bundle (In-Line to Stud)	C-97



Table of Contents - Copper Stud Connectors (continued)



Type N3DR-T Stud to Cable Bundle
(In-line to Stud)

C-98



Type VV3D-R Stud to Cable Bundle
(Flag Position)

C-99



Type VV3D-T Stud to Cable Bundle
(In-line to Stud)

C-100



Type ND-R Stud to Pipe or Cable
(Flag Position)

C-101



Type ND-T Stud to Pipe or Cable
(Flag Position)

C-102



Type N2D-T Stud to Pad
(Perpendicular to Stud)

C-103



Type XD-T Expansion Stud to Pipe
(In-line to Stud)

C-104



Type XDL-T Stud to Pipe (Flag Position)

C-105



Type XD-R Stud to Pipe (Flag Position)

C-106



Type XDL-R Stud to Pipe (Flag Position)

C-107

TYPE FD STUD CONNECTORS

For Use On STUD TO PAD

High copper alloy stud connector allows bolting cable and tubing terminals to equipment studs. Hex head captured bolts provide one-wrench installation. One pad contact surface is on centerline of stud. Pad is finished on both sides. All pads are four hole NEMA drilled.

Material: Copper Alloy
Hardware: DURIMUM™ Silicon Bronze

Notes :

- Plated versions: add the required suffix to the catalog number. -TN for regular tin plating
- Pad is finished on both sides
- Amperage rating given is for indoor conditions
- Please contact factory for other sizes, combinations and availability
- One-wrench installation

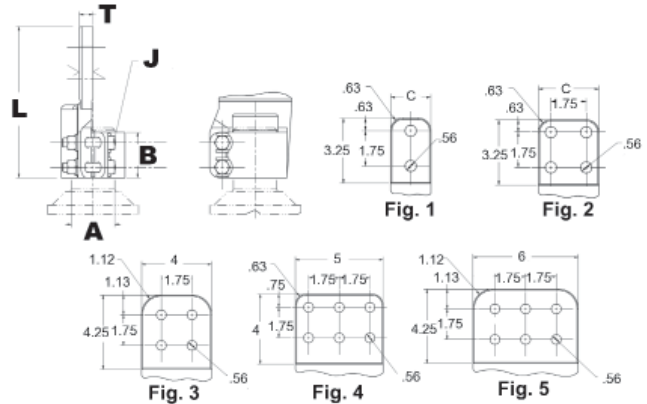
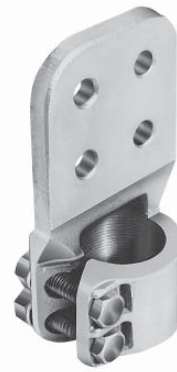

Catalog Number	Fig. #	Stud A	Threads per inch	Nominal Ampere Rating	B	J Dia.	L	T
FD63C6T13	2	1/2	13	1075	1.75	3/8	6.00	3/8
FD635B6T11	1	5/8	11	750	1.75	3/8	6.00	3/8
FD635C6T11	2		11	1075	1.75	3/8	6.00	5/16
FD635C5T0	2		0	1000	1.75	3/8	6.00	3/8
FD64CT16	—		16	700	1.75	3/8	5.72	31/100
FD64B5T16	1	3/4	16	700	1.75	3/8	5.72	3/8
FD64B6	1		12	750	1.75	3/8	5.72	19/50
FD64B6T16	1		16	750	1.75	3/8	5.72	5/16
FD64B5	1		12	700	1.75	3/8	5.72	31/100
FD64B5T0	1		0	700	1.75	3/8	5.72	3/8
FD645C5T14	2		14	1000	1.75	3/8	5.72	5/16
FD64C5	2		12	1000	1.75	3/8	6.00	31/100
FD64C5T10	2		10	1000	1.75	3/8	6.00	31/100
FD64C5T16	2		16	1000	1.75	3/8	5.72	5/16
FD645C5	2		12	1000	1.75	3/8	5.72	5/16
FD64D5	3		12	1200	1.75	3/8	6.78	31/100
FD64D5T0	3		0	1200	1.75	3/8	6.78	3/8

**TYPE FD
STUD CONNECTORS**
(Continued)



Catalog Number	Fig. #	Stud A	Threads per inch	Nominal Ampere Rating	B	J Dia.	L	T	
FD645D8T0	3	7/8	0	1450	1.75	3/8	7.06	1/2	
FD645D16T0	3		0	3000	1.75	3/8	7.06	1	
FD65B6	1	1	12	750	1.75	3/8	5.72	3/8	
FD65C6	2		12	1075	1.75	3/8	5.72	3/8	
FD65C6T0	2		12	1075	1.75	3/8	5.72	19/50	
FD65C6T14	2		14	1075	1.75	3/8	5.72	3/8	
FD65D6T14	3		14	1300	1.75	3/8	6.84	3/8	
FD65D12T0	3		0	2100	1.75	3/8	6.84	3/4	
FD655B6	1		1-1/8	12	750	1.75	3/8	5.80	3/8
FD655C6	2			12	1075	1.75	3/8	5.80	3/8
FD655C6T0	2	12		1075	1.75	3/8	5.80	19/50	
FD655C6T16	2	12		1075	1.75	3/8	5.80	19/50	
FD655D6	3	12		1300	1.75	3/8	6.86	3/8	
FD655D12	3	12		2100	1.75	3/8	6.86	3/4	
FD66B8	1	1-1/4		12	875	1.75	3/8	6.84	1/2
FD66C6	2		12	1075	1.75	3/8	5.78	3/8	
FD66D6	3		12	1300	1.75	3/8	6.84	3/8	
FD66D8	3		12	1450	1.75	3/8	6.84	1/2	
FD675C8	2	1-3/4	12	1100	2.18	1/2	6.32	1/2	
FD675D8	3		12	1450	2.18	1/2	7.39	1/2	
FD675D12	3		12	2100	2.18	1/2	7.39	3/4	
FD68C8	2	2	12	1100	2.18	1/2	6.35	1/2	
FD68D8	3		12	1450	2.18	1/2	7.42	1/2	
FD68D12	3		12	2100	2.18	1/2	7.42	3/4	
FD68D16	3		12	3000	2.18	1/2	7.42	1	
FD685C8	2	2-1/4	12	1100	2.50	1/2	6.71	1/2	
FD685D8	3		12	1450	2.50	1/2	7.77	1/2	
FD685D12	3		12	2100	2.50	1/2	7.77	3/4	
FD685D16	3		12	3000	2.50	1/2	7.77	1	

**TYPE FD
STUD CONNECTORS**
(Continued)

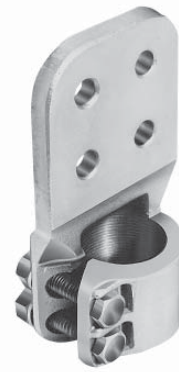

Catalog Number	Fig. #	Stud A	Threads per inch	Nominal Ampere Rating	B	J Dia.	L	T
FD69C8	2	2-1/2	12	1100	2.50	1/2	6.77	1/2
FD69D8	3		12	1450	2.50	1/2	8.03	1/2
FD69D12	3		12	2100	2.50	1/2	8.03	3/4
FD69D16	3		12	3000	2.50	1/2	8.03	1
FD70C8	2	3	12	1100	2.88	5/8	7.21	1/2
FD70D8	3		12	1450	2.88	5/8	8.28	1/2
FD702D16T0	3		0	3000	2.88	5/8	8.26	1
FD70D16HQ	3		12	3000	2.88	5/8	8.24	1
FD70D12	3		12	2100	2.88	5/8	8.26	3/4
FD70D16	3		12	3000	2.88	5/8	8.24	1
FD702D12T0	3		0	2100	2.88	5/8	8.26	3/4
FD71D12	3	3-1/2	12	2100	3.00	5/8	8.78	3/4
FD72D27CG1	3	4	12	3000	3.00	5/8	8.42	1-3/4
FD72D12	3		12	2100	3.00	5/8	8.42	3/4
FD72D22	3		12	4000	3.00	5/8	9.72	1-3/8
FD72D16CG1	6		12	3000	3.00	5/8	10.50	1

TYPE NFD STUD CONNECTORS

For Use On STUD TO PAD

High copper alloy stud connector allows bolting cable and tubing terminals to equipment studs. One pad contact surface is on centerline of stud. The NFD is a body and cap design whereas the FD is a wraparound. NFD is particularly suited when wraparound design is difficult to install due to clearance issues.



Material: Copper Alloy
Hardware: DURIIUM™ Silicon Bronze

Notes :

- Plated versions: add the required suffix to the catalog number. -TN for regular tin plating
- Pad is finished on both sides
- Amperage rating given is for indoor conditions
- Please contact factory for other sizes, combinations and availability
- One-wrench installation.

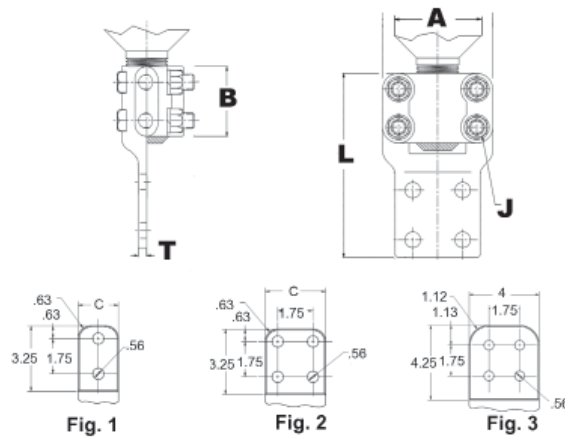

Catalog Number	Fig. #	Stud A	Threads per inch	B	J Dia.	L	T
NFD67C5	2	1-1/2	12	2.50	1/2	6.53	5/16
NFD675C8	2	1-3/4		2.18	1/2	6.31	1/2
NFD68C5	2	2		2.50	1/2	6.53	5/16
NFD68C5W	2			2.50	1/2	6.53	5/16

TYPE FDR STUD CONNECTORS

For Use On STUD TO PAD

High copper alloy stud connector allows bolting cable and tubing terminals to equipment studs. The pad is in a flag position to stud versus in-line.

Material: Copper Alloy
Hardware: DURIUM™ Silicon Bronze

Notes :

- Plated versions: add the required suffix to the catalog number. -TN for regular tin plating
- Pad is finished on both sides
- Amperage rating given is for indoor conditions
- Please contact factory for other sizes, combinations and availability
- One-wrench installation.

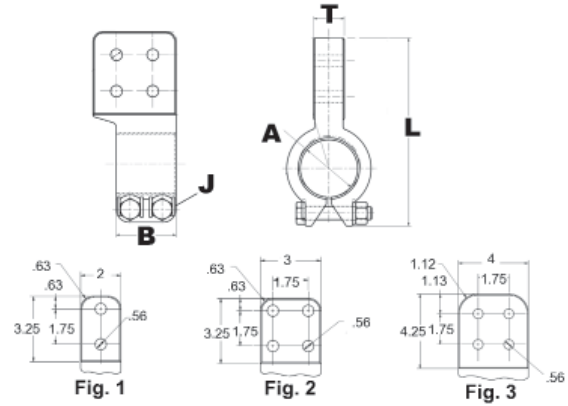
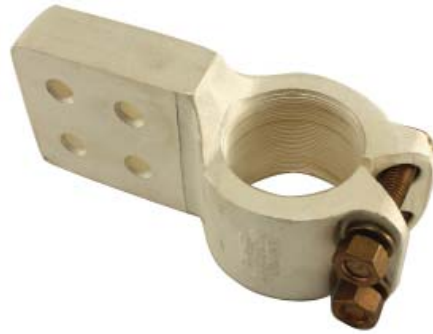

Catalog Number	Fig. #	Stud A	Threads per inch	Nominal Ampere Rating	B	J Dia.	L	T
FDR64B6T10	1	3/4	10	750	1.75	3/8	5.02	31/100
FDR64C6T16	2		16	1075	1.75	3/8	5.02	31/100
FDR65C6T14	2	1	14	1075	1.75	3/8	5.27	19/50
FDR655B6	1	1-1/8	12	750	1.75	3/8	5.44	19/50
FDR655C6	2		12	1075	1.75	3/8	5.44	19/50
FDR655D6	3		12	1300	1.75	3/8	6.5	19/50
FDR66B6	1	1-1/4	12	750	1.75	3/8	5.57	19/50
FDR66C6	2		12	1075	1.75	3/8	5.57	19/50
FDR66D6	3		12	1300	1.75	3/8	6.63	19/50
FDR67B6	1	1-1/2	12	750	2.18	1/2	5.99	19/50
FDR67C6	2		12	1075	2.18	1/2	5.99	19/50
FDR67D8	3		12	1450	2.18	1/2	7.05	1/2
FDR675C6	2	1-3/4	12	1075	2.18	1/2	6.31	19/50
FDR675D8	3		12	1450	2.18	1/2	7.37	1/2
FDR68D8	3	2	12	1450	2.18	1/2	7.66	1/2
FDR69D8	3	2-1/2	12	1450	2.50	1/2	8.54	1/2
FDR70D12	3	3	12	2100	2.88	5/8	9.18	3/4

TYPE FDA STUD CONNECTORS

For Use On STUD TO PAD

High copper alloy stud connector allows bolting cable and tubing terminals to equipment studs. Pad contact surface is perpendicular to the centerline of the stud.

Material: Copper Alloy
Hardware: DURIMUM™ Silicon Bronze

Notes :

- Plated versions: add the required suffix to the catalog number. -TN for regular tin plating
- Pad is finished on both sides
- Amperage rating given is for indoor conditions
- Please contact factory for other sizes, combinations and availability
- One-wrench installation.

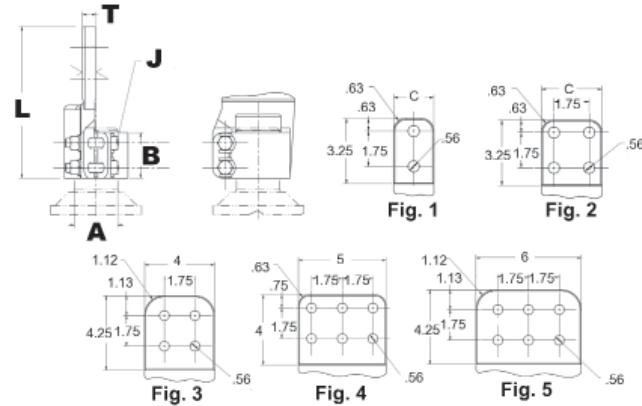

Catalog Number	Fig. #	Stud A	Threads per inch	B	J Dia.	L	T
FDA655B6	1	1-1/8	12	1.75	3/8	5.44	3/8
FDA655C6	2			1.75	3/8	5.44	3/8
FDA655D6	3			1.75	3/8	5.44	3/8
FDA66C6	—	1-1/4		1.75	3/8	5.57	3/8
FDA67C6	2	1-1/2		2.18	1/2	5.98	3/8
FDA67D8	3			2.18	1/2	7.05	1/2
FDA68D8	3	2		2.18	1/2	7.66	1/2
FDA68D12	3			2.18	1/2	7.81	3/4
FDA70D12	3			3	2.88	5/8	9.19

**TYPE NDR
STUD CONNECTORS**

For Use On COPPER STUD TO CABLE

High copper alloy reversible and rotatable cap stud connector joins cable, tube and flat bar in-line or at right angles to equipment studs. Accommodates a wide range of cables or tubes. One-wrench installation.

Material: Copper Alloy
Hardware: DURIU™ Silicon Bronze

Notes :

- Plated versions: add the required suffix to the catalog number. -TN for regular tin plating
- Please contact factory for other sizes, combinations and availability
- One-wrench installation.

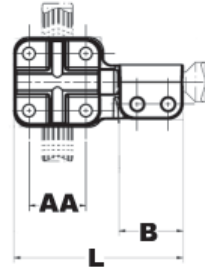

Catalog Number	Stud A	Threads per inch	B	AA Stranded Cable	JJ Dia.	L	H
NDR6334T13	1/2	13	1.62	6-500	3/8	4.28	2.25
NDR6328T13		13	1.53	6-4/0	3/8	3.62	1.75
NDR6434T12	3/4	12	1.53	6-500	3/8	4.09	2.24
NDR6434T16		16	1.53		3/8	4.09	
NDR6428T16		16	1.53	6-4/0	3/8	3.60	1.74
NDR6444T16		16	1.53	2-1000	1/2	4.66	2.82
NDR64534T14	7/8	14	1.53	6-500	3/8	4.16	1.91
NDR6534T12	1	12	1.53		3/8	3.96	2.24
NDR6534T14		14	1.53	3/8	3.96		
NDR6528T14		14	1.53	6-4/0	3/8	4.09	1.74
NDR6544T14		14	1.53	2-1000	1/2	4.73	2.82
NDR65534T12		1-1/8	12	1.53	6-500	3/8	3.97
NDR65528T12	12		1.53	6-4/0	3/8	4.12	1.75
NDR65544T12	12		1.53	2-1000	1/2	4.66	2.82
NDR6748T12	1-1/2	12	2.03	4/0-2000	1/2	5.78	3.25
NDR67548T12	1-3/4	12	2.03		1/2	6.56	2.51
NDR67544T12		12	2.03	2-1000	1/2	6.28	3.12
NDR6848T12	2	12	2.03	4/0-2000	1/2	6.56	2.82
NDR6844T12		12	2.03	2-1000	1/2	6.12	2.88
NDR68544T12		12	2.50		1/2	6.81	3.12

**TYPE VVD-R
STUD CONNECTORS**

For Use On STUD TO CABLE - FLAG

High copper alloy stud connector allows bolting cable to equipment studs. Cables are in a flag position to the stud.

Material: Copper Alloy
Hardware: DURIMUM™ Silicon Bronze

Notes :

- Plated versions: add the required suffix to the catalog number. -TN for regular tin plating
- Please contact factory for other sizes, combinations and availability
- One-wrench installation.
- V-bolt clamping element is particularly appropriate for flexible cables

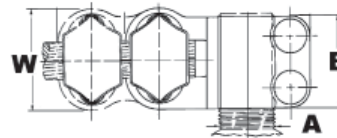
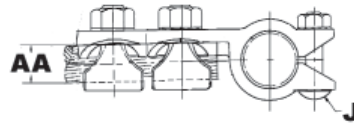
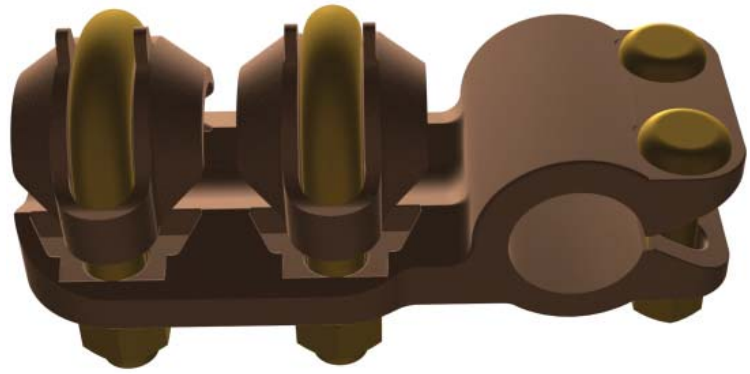

Catalog Number	Stud A	AA Stranded Cable	Threads per inch	B	J Dia.	W
VVD6740R12	1-1/2	500 kcmil-800 kcmil	12	3.75	1/2	2.62
VVD6746R12		1000 kcmil-1500 kcmil	12	4.75	5/8	3.25
VVD6840R12	2	500 kcmil-800 kcmil	12	3.75	1/2	2.62
VVD6846R12		1000 kcmil-1500 kcmil	12	4.75	5/8	3.25
VVD7046R12	3	1000 kcmil-1500 kcmil	12			5/8

**TYPE VVD-T
STUD CONNECTORS**

For Use On STUD TO CABLE - IN LINE

High copper alloy stud connector allows bolting cable to equipment studs. The cable is positioned in-line with the stud.

Material: Copper Alloy
Hardware: DURIMUM™ Silicon Bronze

Notes :

- Plated versions: add the required suffix to the catalog number. -TN for regular tin plating
- Please contact factory for other sizes, combinations and availability
- One-wrench installation.
- V-bolt clamping element is particularly appropriate for flexible cables.

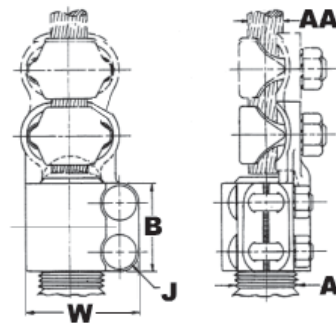
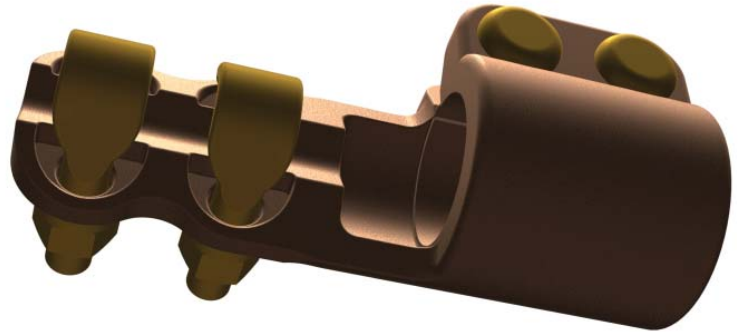

Catalog Number	Stud A	AA Stranded Cable	Threads per inch	J Dia.	B	W
VVD6328T13	1/2	1/0 AWG-4/0 AWG	13	3/8	1.38	1.28
VVD67534T12	1-3/4	300 kcmil-500 kcmil	12	1/2	2.75	3.24
VVD6740T12	1-1/2	500 kcmil-800 kcmil	12		3.75	2.62
VVD6746T12		1000 kcmil-1500 kcmil	12	5/8	4.75	3.25
VVD7046T12	3	1000 kcmil-1500 kcmil	12		4.75	3.25

TYPE N2DR STUD CONNECTORS

For Use On STUD TO (2) CABLES

High copper alloy stud connector allows bolting (2) cables to equipment studs. The cables are held in a flag position to the stud connector.

Material: Copper Alloy

Hardware: DURIMUM™ Silicon Bronze

Notes :

- Plated versions: add the required suffix to the catalog number. -TN for regular tin plating
- Contact factory for other variations (drilling, size, threading...) and availability
- One-wrench installation.

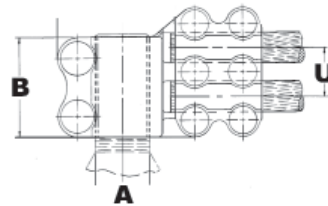
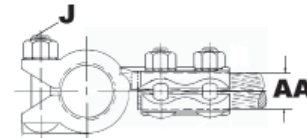

Catalog Number	Stud A	Threads per inch	AA Stranded Cable	AA Tube	B	U	J Dia.
N2DR6644T12	1-1/4	12	1 AWG-1000 kcmil	3/8 IPS -3/4 IPS	1.75	3.12	1/2
N2DR6744T12	1-1/2		1 AWG-1000 kcmil		2.25		

TYPE N11DR STUD CONNECTORS

For Use On STUD TO (2) CABLES

High copper alloy stud connector allows bolting (2) cables to equipment studs. Cable orientation is either flag or in-line to the stud.

Material: Copper Alloy

Hardware: DURIMUM™ Silicon Bronze

Notes :

- Plated versions: add the required suffix to the catalog number. -TN for regular tin plating
- Contact factory for other variations (drilling, size, threading...) and availability
- - W for extra thick tin plating (including hardware)
- One-wrench installation.

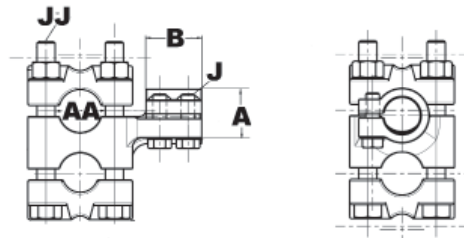

Catalog Number	Stud A	Threads per inch	AA Stranded Cable	AA Pipe	B	J Dia.	JJ Dia.
N11DR6434T16	3/4	16	6 AWG-500 kcmil	3/8 IPS -1/2 IPS	1.53	3/8	3/8
N11DR6544T12	1	12	2 AWG-1000 kcmil	3/8 IPS -3/4 IPS	1.53	3/8	1/2
N11DR6534T14		14	6 AWG-500 kcmil	3/8 IPS -1/2 IPS	1.53	3/8	3/8
N11DR6744T12	1-1/2	12	2 AWG-1000 kcmil	3/8 IPS -3/4 IPS	2.03	1/2	1/2
N11DR6744T0		0	2 AWG-1000 kcmil		2.03	1/2	
N11DR6734T12		12	6 AWG-500 kcmil	3/8 IPS -1/2 IPS	2.03	1/2	3/4
N11DR67544T12	1-3/4	12	2 AWG-1000 kcmil	3/8 IPS -3/4 IPS	2.03	1/2	1/2
N11DR6844T12	2	12	2 AWG-1000 kcmil		2.03	1/2	
N11DR6848T12		12	4/0 AWG-2000 kcmil	3/8 IPS -1 1/4 IPS	2.50	1/2	
N11DR7048T12	3	12	4/0 AWG-2000 kcmil	3/8 IPS -1 1/4 IPS	2.88	5/8	

TYPE VV2D-R STUD CONNECTORS

For Use On STUD TO (2) CABLES -
FLAG

High copper alloy stud connector allows bolting (2) cables to equipment studs. The cables are held in a flag position to the equipment stud.

Material: Copper Alloy

Hardware: DURIMUM™ Silicon Bronze

Notes :

- Plated versions: add the required suffix to the catalog number. -TN for regular tin plating
- Please contact factory for other sizes, combinations and availability
- One-wrench installation.
- V-bolt clamping element is particularly appropriate for flexible cables

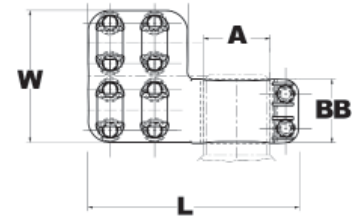
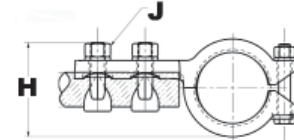
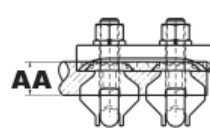

Catalog Number	Stud A	Threads per inch	AA - Stranded Cable	J Dia.	W	L	BB	H
VV2D6740R12	1-1/2	12	500 kcmil-800 kcmil	1/2	5.50	7.19	2.69	3.12
VV2D6746R12		12	1000 kcmil-1500 kcmil		6.75	7.82		3.50
VV2D6846R12	2	12	1000 kcmil-1500 kcmil	5/8	6.75	8.69	3.25	3.50
VV2D7044R12	3	12	750 kcmil-1000 kcmil		6.25	9.13		4.25

**TYPE VV2D-T
STUD CONNECTORS**

For Use On STUD TO (2) CABLES - IN LINE

High copper alloy stud connector allows bolting (2) cables to equipment studs. The cables are positioned in-line to the equipment stud.

Material: Copper Alloy
Hardware: DURIMUM™ Silicon Bronze

Notes :

- Plated versions: add the required suffix to the catalog number. -TN for regular tin plating
- Please contact factory for other sizes, combinations and availability
- One-wrench installation.
- V-bolt clamping element is particularly appropriate for flexible cables.

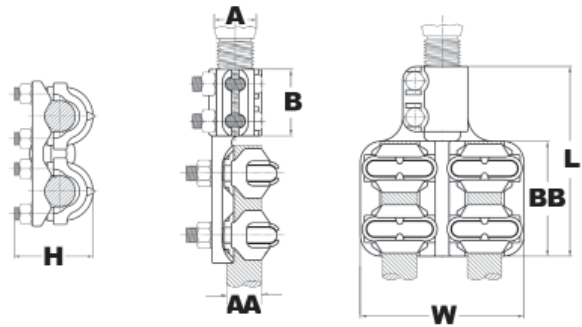

Catalog Number	Stud A	Threads per inch	AA Stranded Cable	B	BB	L	H	W
VV2D6740T12	1-1/2	12	500 kcmil-800 kcmil	2.69	3.75	6.81	2.84	5.47
VV2D6746T12		12	1000 kcmil-1500 kcmil		4.75	7.83	3.67	6.72
VV2D6946T12	2-1/2	12	1000 kcmil-1500 kcmil		4.75	7.81	3.25	6.72

TYPE N3DR STUD CONNECTORS

For Use On STUD TO (3) CABLE

High copper alloy stud connector allows bolting (3) cables to equipment studs. The cables are positioned in-line to the equipment stud.

Material: Copper Alloy

Hardware: DURIMUM™ Silicon Bronze

Notes :

- Plated versions: add the required suffix to the catalog number. -TN for regular tin plating
- Contact factory for other variations (drilling, size, threading...) and availability
- One-wrench installation.

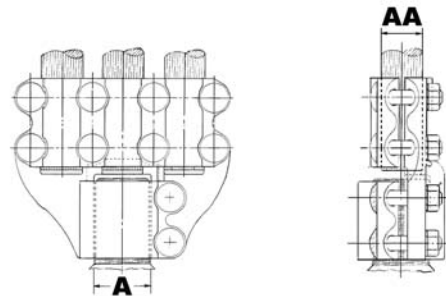

Catalog Number	Stud A	Threads per inch	AA Stranded Cable
N3DR65544T12	1-1/8	12	2 AWG-1000 kcmil
N3DR6844T12	2	12	2 AWG-1000 kcmil
N3DR7044T12	3	12	2 AWG-1000 kcmil

**TYPE VV3D-R
STUD CONNECTORS**

For Use On STUD TO (3) CABLES - FLAG

High copper alloy stud connector allows bolting (3) cables to equipment studs. The cables have a flag position to equipment stud axis.

Material: Copper Alloy
Hardware: DURIMUM™ Silicon Bronze

Notes :

- Plated versions: add the required suffix to the catalog number. -TN for regular tin plating
- Please contact factory for other sizes, combinations and availability
- One-wrench installation.
- V-bolt clamping element is particularly appropriate for flexible cables

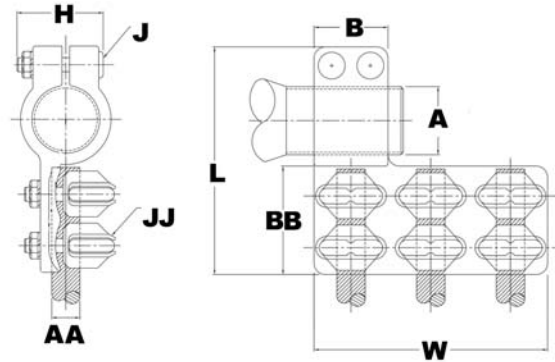

Catalog Number	Stud A	AA Stranded Cable	B	BB	J Dia.	JJ Dia.	L	H	W
VV3D6846R12	2	1000 kcmil-1500 kcmil	4.50	3.25	5/8	5/8	8.38	3.81	10.2
VV3D7046R12	3	1000 kcmil-1500 kcmil	4.50		5/8	5/8	10.0	3.81	10.2
VV3D7246R12	4	1000 kcmil-1500 kcmil	4.50		5/8	5/8	10.5	3.81	10.2

**TYPE VV3D-T
STUD CONNECTORS**

For Use On STUD TO (3) CABLES

High copper alloy stud connector allows bolting (3) cables to equipment studs. The cables are positioned inline to the equipment stud axis.

Material: Copper Alloy
Hardware: DURIMUM™ Silicon Bronze

Notes :

- Plated versions: add the required suffix to the catalog number. -TN for regular tin plating
- Please contact factory for other sizes, combinations and availability
- One-wrench installation.
- V-bolt clamping element is particularly appropriate for flexible cables.

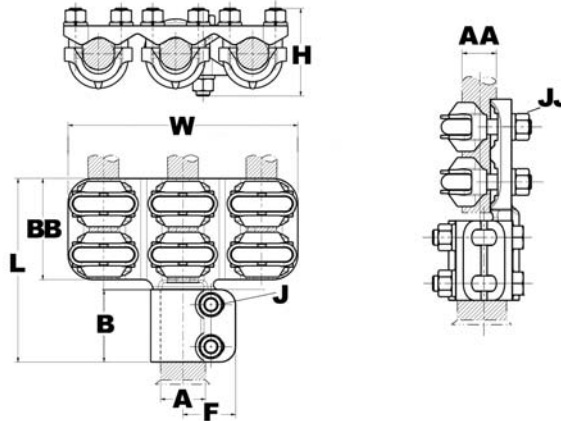

Catalog Number	Stud A	AA Stranded Cable	B	BB	J Dia.	JJ Dia.	L	F	H	W
VV3D6746T12	1-1/2	1000 kcmil-1500 kcmil	4.50	3.25	5/8	5/8	8.05	1.59	4.02	10.2
VV3D6846T12	2	1000 kcmil-1500 kcmil	4.50		5/8	5/8	8.19	1.59	4.02	10.2
VV3D7046T12	3	1000 kcmil-1500 kcmil	4.50		5/8	5/8	8.31	1.59	4.50	10.2

TYPE ND-R STUD CONNECTORS

For Use On STUD TO PIPE/CABLE - FLAG

High copper alloy stud connector allows bolting tube to equipment studs. The tube is flag positioned with respect to the stud axis.

Material: Copper Alloy
Hardware: DURIMUM™ Silicon Bronze

Notes :

- Plated versions: add the required suffix to the catalog number. -TN for regular tin plating
- Please contact factory for other sizes, combinations and availability
- One-wrench installation.

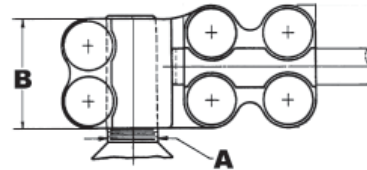
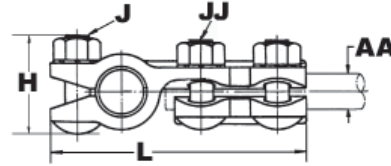

Catalog Number	Stud A	Threads per inch	AA Cable	AA Pipe	B	J Dia.	JJ Dia.	L	H
ND6327R13	1/2	13	3/0 AWG	—	2.00	3/8	3/8	3.75	1.44
ND65526R12	1-1/8	12	2/0 AWG	—	2.00	3/8	3/8	4.56	2.00
ND65517R12			N/A	1 1/2 IPS	2.75	1/2	1/2	6.00	2.88
ND6634R14	1-1/4	14	500 kcmil	—	2.00	3/8	3/8	4.88	2.00
ND6644R14			1000 kcmil		2.00	3/8	3/8	5.50	2.00
ND6728R12	1-1/2	12	4/0 AWG	—	2.00	3/8	3/8	4.75	2.13
ND6734R12			500 kcmil		2.00	3/8	3/8	5.19	2.13
ND6739R12			750 kcmil		2.00	3/8	3/8	5.44	2.13
ND6718R12			N/A		2 IPS	2.69	1/2	1/2	6.00
ND6839R12	2	12	750 kcmil	—	2.00	3/8	3/8	6.00	2.75
ND6844R12			1000 kcmil		2.69	1/2	1/2	6.63	2.75

TYPE ND-T STUD CONNECTORS

For Use On STUD TO PIPE/CABLE -
FLAG

High copper alloy stud connector allows bolting
tube to equipment studs. The tube is positioned
in-line to the stud axis.

Material: Copper Alloy
Hardware: DURIMUM™ Silicon Bronze

Notes :

- Plated versions: add the required suffix to the catalog number. -TN for regular tin plating
- Please contact factory for other sizes, combinations and availability
- One-wrench installation.

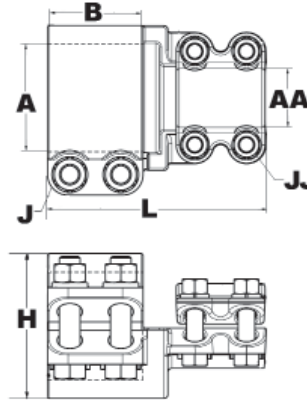

Catalog Number	Stud A	Threads per inch	AA Cable	AA Pipe	B	J Dia.	JJ Dia.	L	H		
ND6428T16	3/4	16	4/0 AWG	—	2.00	3/8	3/8	4.50	1.75		
ND6414T16				3/4 IPS	2.00	3/8	3/8	4.50	2.00		
ND6513T12	1	12	N/A	1/2 IPS	2.00	3/8	3/8	4.56	1.94		
ND65516T12	1-1/8			1 1/4 IPS	2.69	1/2	1/2	6.00	2.62		
ND65515T12				1 IPS	1.32	3/8	3/8	4.56	2.12		
ND6639T14	1-1/4	14	750 kcmil	—	2.00	3/8	3/8	5.25	2.00		
ND6615T12		1-1/2	12	N/A	1 IPS	2.00	3/8	3/8	4.56	2.12	
ND67T12CG20	1/0 -1250 kcmil			1/4 IPS - 1 IPS	2.68	1/2	1/2	6.57	2.52		
ND6745T12HQ					2.69	1/2	1/2	6.56	3.11		
ND6716T12	1-1/2			12	N/A	1 1/4 IPS	2.69	1/2	1/2	6.00	2.63
ND6715T12						1 IPS	2.00	3/8	3/8	4.59	2.25
ND6714T12		3/4 IPS	2.00			3/8	3/8	4.59	2.25		
ND6848T12	2	12	2000 kcmil	—	2.69	1/2	1/2	6.88	2.88		
ND6845T12HQ			1/0 -1250 kcmil	1/4 IPS - 1 IPS	2.69	1/2	1/2	6.58	3.36		
ND6815T12			N/A	1 IPS	2.00	3/8	3/8	4.65	2.75		
ND6818T12				2 IPS	2.69	1/2	1/2	6.07	3.88		

TYPE N2D STUD CONNECTORS

For Use On STUD TO (2) CABLES

High copper alloy stud connector allows bolting (2) cables to equipment studs. The cables are held in an in-line position to the stud connector.

Material: Copper Alloy

Hardware: DURIMUM™ Silicon Bronze

Notes :

- One wrench installation
- Plated versions: add -TN for regular tin plating; -W for extra thick tin plating (incl. hardware); and -SV for silver plating.
- Contact factory for other variations (drilling, size, threading, etc.) and availability.

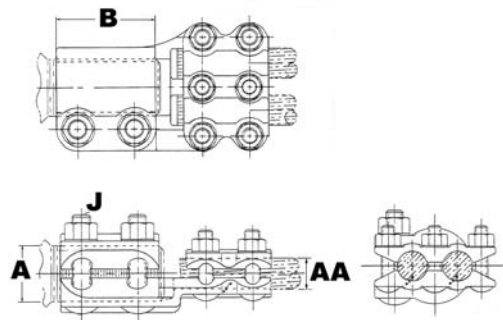

Catalog Number	Stud A	Threads per inch	AA Stranded Cable	B	J Dia.
N2D6734T12	1-1/2	12	500 kcmil	2.69	1/2
N2D6731T12			350 kcmil	2.03	1/2
N2D67534T12	1-3/4		500 kcmil	2.31	3/8
N2D67539T12			750 kcmil		1/2
N2D6834T12	2		500 kcmil	2.50	3/8

TYPE XD-T STUD CONNECTORS

For Use On EXPANSION STUD TO TUBE

High copper alloy expansion terminal for stud to tube. Provides for longitudinal movement of tubing. Extra flexible braid carries full load of joint.

Material: Copper Alloy

Hardware: DURIMUM™ Silicon Bronze

Notes :

- Installation instructions available upon request
- Please contact factory for other sizes, combinations and availability
- One-wrench installation.

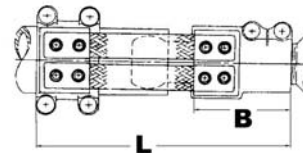
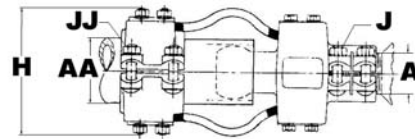

Catalog Number	Stud A	Threads per inch	AA Pipe	B	J Dia.	JJ Dia.	L	H
XD6515T14	1	14	1 IPS	2.00	3/8	3/8	9.63	4.31
XD65517T12	1-1/8	12	1 1/2 IPS	2.69	1/2	1/2	12.50	6.06
XD6714T12	1-1/2		3/4 IPS	2.00	3/8	3/8	8.88	4.06
XD6715T12		1 IPS	3/8		3/8	9.63	4.19	
XD6714T14		14	3/4 IPS	2.69	3/8	3/8	8.88	4.06
XD6718T12		12	2 IPS		1/2	1/2	12.50	7.00
XD6716T12			1 1/4 IPS	1/2	1/2	12.00	5.81	
XD6717T12			1 1/2 IPS	1/2	1/2	12.50	6.06	
XD67520T12		1-3/4	12	3 IPS	2.03	1/2	5/8	15.38
XD6816T12	2	1 1/4 IPS		2.69	1/2	1/2	12.00	6.50

TYPE XDL-T STUD CONNECTORS

For Use On EXPANSION STUD TO TUBE (NO GUIDE)

High copper alloy expansion terminal for stud to tube. Provides for longitudinal movement of tubing without guide. Extra flexible braid carries full load of joint.

Material: Copper Alloy

Hardware: DURIMUM™ Silicon Bronze

Notes :

- Installation instructions available upon request
- Please contact factory for other sizes, combinations and availability
- One-wrench installation.

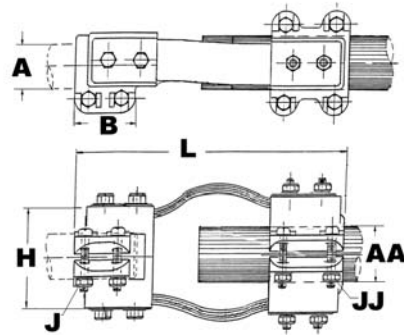

Catalog Number	Stud A	Threads per inch	B	J Dia.	AA Pipe	JJ Dia.	L	H
XDL6715T12	1 1/2	12	2.00	3/8	1 IPS	3/8	9.63	4.19

TYPE XD-R STUD CONNECTORS

For Use On EXPANSION STUD TO TUBE (FLAG)

High copper alloy expansion terminal for stud to tube. Provides for longitudinal movement of tubing. Extra flexible braid carries full load of joint.

Material: Copper Alloy

Hardware: DURIMUM™ Silicon Bronze

Notes :

- Installation instructions available upon request
- Please contact factory for other sizes, combinations and availability
- One-wrench installation.

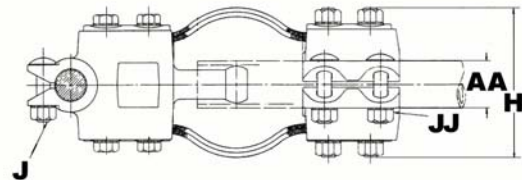
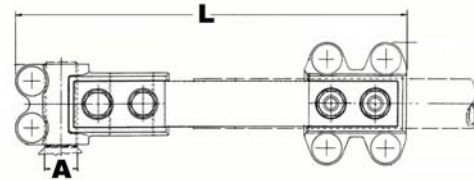
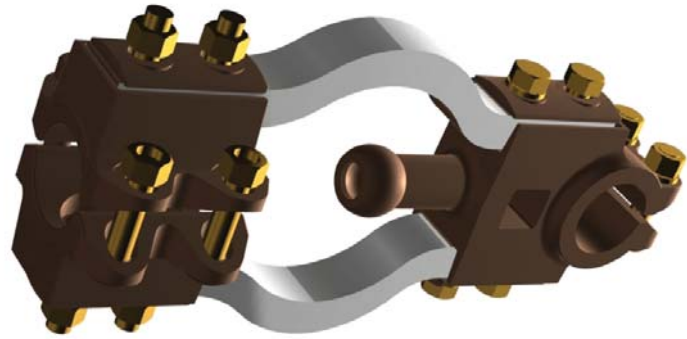

Catalog Number	Stud A	Threads per inch	AA Pipe Conductor	J Dia.	JJ Dia.	L	H
XD65517R12	1-1/8	12	1 1/2 IPS	1/2	1/2	13.13	6.13
XD6719R12	1-1/2		2 1/2 IPS		1/2	14.88	8.56
XD6716R12			1 1/4 IPS		1/2	12.50	5.88
XD6718R12			2 IPS		1/2	13.13	7.00
XD6715R12	1-1/2		1 IPS	3/8	3/8	10.63	4.38
XD6714R12			3/4 IPS		3/8	9.63	4.13
XD6714R14			14	3/4 IPS		3/8	
XD6819T12	2	12	2 1/2 IPS	1/2	1/2	13.25	8.50
XD6818R12			2 IPS		1/2	14.44	7.00

TYPE XDL-R STUD CONNECTORS

For Use On EXPANSION STUD TO TUBE (FLAG | NO GUIDE)

High copper alloy expansion terminal for stud to tube. Provides for longitudinal movement of tubing without guide. Extra flexible braid carries full load of joint.

Material: Copper Alloy

Hardware: DURIMUM™ Silicon Bronze

Notes :

- Installation instructions available upon request
- Please contact factory for other sizes, combinations and availability
- Installation instructions available upon request
- For other sizes or configurations, please call factory

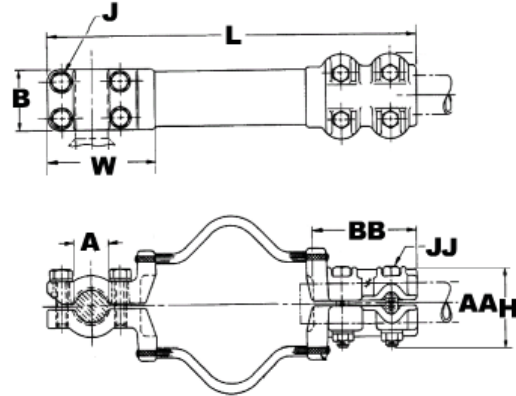

Catalog Number	Stud A	Threads per inch	AA Pipe Conductor	B	J Dia.	BB	JJ Dia.	L	H	W
XDL6717R12	1 1/2	12	1 1/2 IPS	2.69	1/2	3.50	1/2	13.19	6.18	2.69

Table of Contents - Copper Bus Bar

	Type FB Bar to Pad	C-111
	Type FCB Transformer Tap Adaptor	C-112
	Type HFB Bar Clamp	C-113
	Type HFB-P1 Bar Clamp Components	C-114
	Type HFBW Bar Clamp	C-115
	Type HHH Bar Clamp Bus Support	C-116
	Type HP Spacer	C-117
	Type E-C-G Multi-tap	C-118
	Type HFB Bar Clamp Tap Pad Adapter	C-119
	Type QGFL Bartap	C-120

**TYPE FB
BUS BARS**

For Use On BAR TO PAD

High copper alloy transformer tap adaptor designed to accommodate from 1 to 6 NEMA drilled copper or aluminium terminal taps from a single secondary.

Material: Bronze Alloy

Notes :

- Plated versions: add the required suffix to the catalog number. -TN for regular tin plating
- Please contact factory for other sizes, combinations and availability

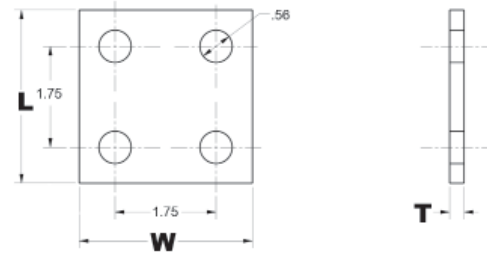
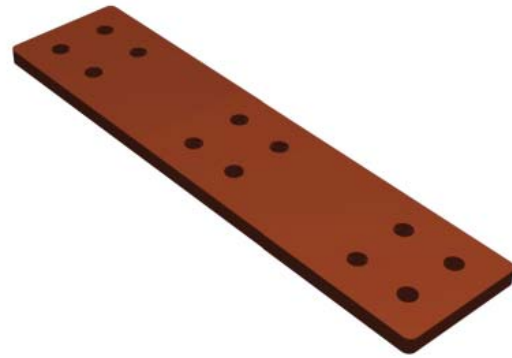

Catalog Number	L	T	W
FB11G3LD	2.00	0.25	1.00
FB13G20	10.20	0.50	3.00
FB13G21W	12.00	0.50	3.00
FB13G22	18.00	0.50	3.00
FB13G23	18.00	0.75	3.00
FB14ACG1	16.50	1.00	4.00

**TYPE FCB
TRANSFORMER
TAP ADAPTERS**

For Use On COPPER AND ALUMINIUM

Cast in one piece from copper alloy. Transformer tap adapter designed to accommodate from 1 to 6 NEMA drilled copper or aluminum terminal taps from a single secondary transformer outlet. Tin-plated. Order mounting hardware and tap terminals separately.

Material: Copper

Notes :

- Plated versions: add the required suffix to the catalog number. -TN for regular tin plating
- Please contact factory for other sizes, combinations and availability

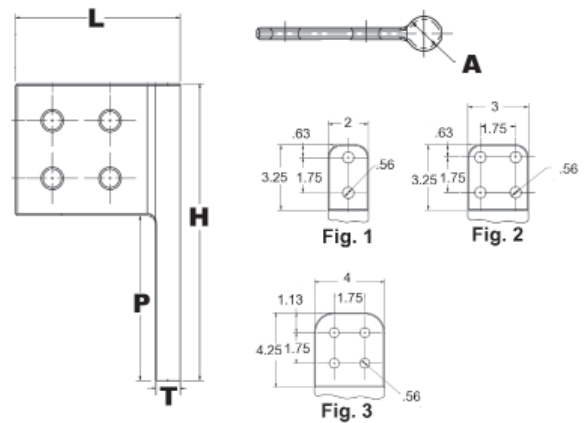

Catalog Number	A	H	P	T	L
FCB63-2NP300	1/2	5.00	3.00	0.25	3.50
FCB63-4N	1/2	5.25	2.25	0.25	3.75
FCB63-6N	1/2	5.25	2.25	0.25	5.50
FCB642NP300	3/4	5.00	3.00	0.25	3.75
FCB64-44NP50	3/4	9.00	5.00	0.25	5.00
FCB644G4	3/4	7.50	4.50	0.25	4.25
FCB64-4N	3/4	5.75	2.75	0.25	4.00
FCB64-6N	3/4	5.75	2.75	0.25	5.75
FCB65-4N	1	7.00	4.00	0.25	4.25

**TYPE HFB
BAR CLAMPS**

For Use On FOR COPPER BAR

To build your own high strength clamp assembly for multiple flat bar using type HFBP1 bar clamps and clamping hardware, the following tables have been provided. The clamp assembly eliminates the need for drilling the flat bar and is used in indoor and outdoor applications.

Material: Copper Alloy

Notes :

- Please contact factory for other sizes, combinations and availability

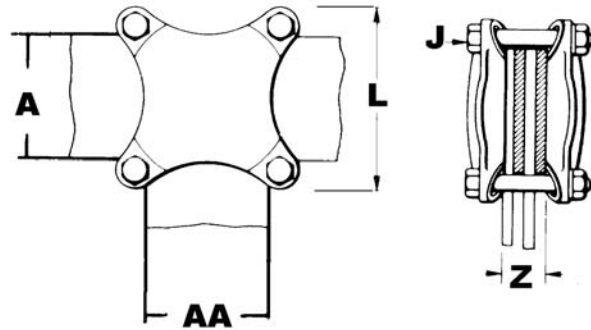

Catalog Number	A	AA	J Dia.	Z	L
HFB22	2.00	2.00	3/8	0.75	3.31
HFB33	3.00	3.00	3/8	1.25	4.31
HFB33CG3	3.00	3.00	3/8	1.25	4.31
HFB42	4.00	2.00	3/8	1.25	5.31
HFB43CG1	4.00	3.00	1/2	1.25	5.31
HFB44	4.00	4.00	1/2	1.25	5.75
HFB44CG11	4.00	4.00	1/2	1.25	5.75
HFB44T16	4.00	4.00	1/2	1.25	5.75

TYPE HFB-P1 BAR CLAMP ASSEMBLY COMPONENTS

For Use On COPPER BAR

To build your own high strength clamp assembly for multiple flat bar using type HFB-P1 bar clamps and clamping hardware, the following tables have been provided. The clamp assembly eliminates the need for drilling the flat bar and may be used in either indoor and outdoor applications.

Material: Copper Alloy

Notes :

- Please contact factory for other sizes, combinations and availability

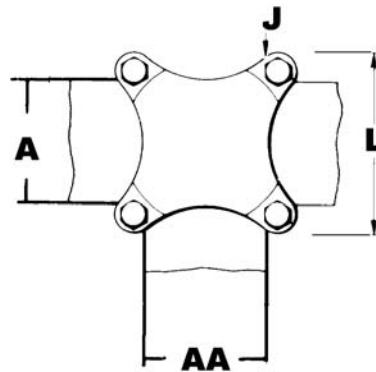

Catalog Number	A	AA	J Dia.	L
HFB22P1	2.00	2.00	3/8	4.38
HFB33P1	3.00	3.00	3/8	4.38
HFB42P1	4.00	2.00	3/8	5.75
HFB44P1	4.00	4.00	1/2	5.75
HFB52P1	5.00	2.00	1/2	6.75
HFB53P1	5.00	3.00	1/2	6.75
HFB54P1	5.00	4.00	1/2	6.75
HFB55P1	5.00	5.00	5/8	7.13
HFB62P1	6.00	2.00	1/2	7.75
HFB63P1	6.00	3.00	1/2	7.75
HFB64P1	6.00	4.00	1/2	7.75

**TYPE HFBW
BAR CLAMPS**

For Use On COPPER BAR

The clamp assembly eliminates the need for drilling the flat bar and may be used in either indoor and outdoor applications. The open web design provides a uniform clamping pressure while minimizing the weight of the connector.

Material: Copper Alloy

Notes :

- Please contact factory for other sizes, combinations and availability

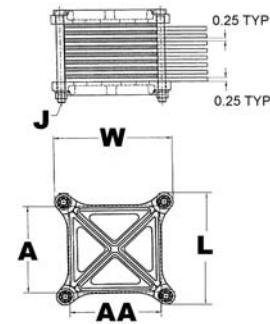

Catalog Number	A	AA	J Dia.	L	W
HFB44G30W	4.00	4.00	1/2	5.75	5.75
HFB44G31W	4.00	4.00	1/2	5.75	5.75
HFB44G32W	4.00	4.00	1/2	5.75	5.75

**TYPE HHH
BAR CLAMPS**

For Use On COPPER BAR

High Copper alloy horizontal bus support. The clamp assembly eliminates the need for drilling the flat bar and may be used in either indoor and outdoor applications. The open web design provides a uniform clamping pressure while minimizing the weight of the connector.

Material: Copper Alloy

Notes :

- Please contact factory for other sizes, combinations and availability

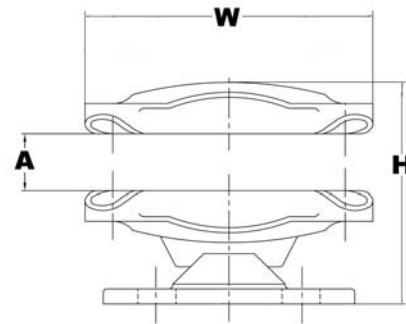
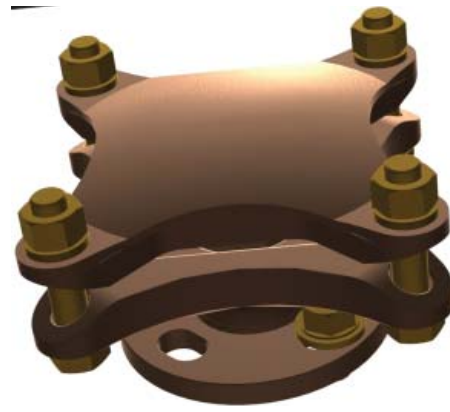

Catalog Number	A	H	W
HHHB423	2.00	5.06	3.31
HHHB143	4.00	3.88	5.75
HHHB853	5.00	7.81	7.25

TYPE HP SPACERS

For Use On COPPER BAR

High copper alloy spacer, mainly used for H-clamps.

Material: Copper Alloy

Notes :

- Please contact factory for other sizes, combinations and availability

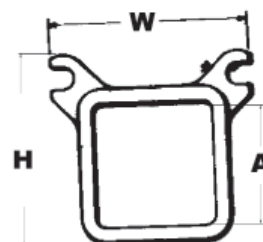

Catalog Number	A	H	W
HP44	4.00	4.88	5.20
HP53	5.00	5.88	4.20
HP66	6.00	7.06	7.43

**TYPE E-C-G
TAP ADAPTERS**

For Use On For Copper

Multi-tap, range-taking cast copper alloy connector designed to take 2, 3 or 4 conductors from a single secondary transformer outlet

Material: Copper Alloy



Notes :

- Plated versions: add the required suffix to the catalog number. -TN for regular tin plating
- Please contact factory for other sizes, combinations and availability

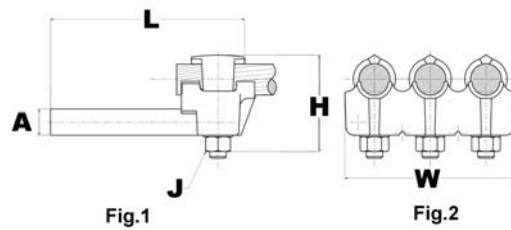

Catalog Number	Number of Conductors	Conductor Size	A dia	H	J Dia.	L	W
E2C34G1	2	1/0 AWG-500 kcmil	0.78	3.88	1/2	6.25	3.50
E3C34G1	3	1/0 AWG-500 kcmil	0.78	3.88	1/2	6.25	5.25
E4C34G1	4	1/0 AWG-500 kcmil	0.78	3.88	1/2	6.25	6.88

**TYPE HFB-N
BAR CLAMP TAP PAD
ADAPTERS**

For Use On FOR COPPER BAR

High conductivity copper, tap pad adapter provides a NEMA drilled contact pad when assembled to the HFB-P1 clamps. Tap connections can be made from copper bus bar(s) without drilling, by bolting standard mechanical or compression terminal pads directly to the pre-drilled tap pad adapter

Material: Copper

Notes :

- Please contact factory for other sizes, combinations and availability

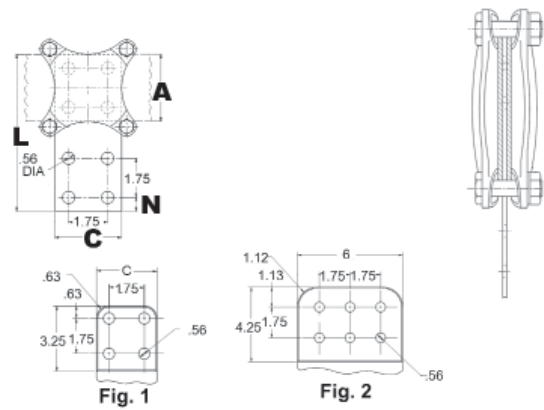
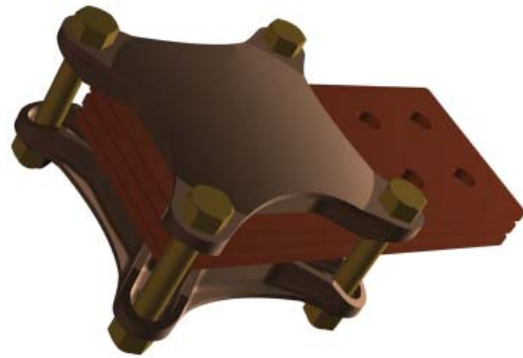

Catalog Number	A	C	L	N
HFB33-4N	3.00	3.00	7.00	0.62
HFB44-4N	4.00	4.00	9.12	1.12
HFB66-6N	6.00	6.00	11.31	1.12

**TYPE QGFL
BARTAP™**

For Use On For Copper Cable
to Flat Bar or Pad

High copper alloy BARTAP™ for
joining a range of cable to bar or pad.
One-wrench installation. DURIMUM™
nut and lockwasher.

Material: Copper Alloy

Notes :
Can be installed side by side or in-line
on NEMA drilled bar.

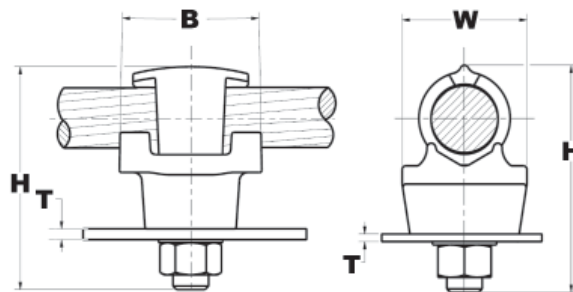

Catalog Number	Copper Conductor	B	H	J Dia.	T (Max)	W
QGFL1CB1	10 AWG-1 AWG	1-1/8	1-7/8	3/8	1/4	1
QGFL1CB1T6	10 AWG-1 AWG	1-1/8	2-3/8	3/8	3/4	1
QGFL26B1	8 AWG-2/0 AWG	1-1/4	2-1/8	3/8	1/4	1-1/8
QGFL26B1T6	8 AWG-2/0 AWG	1-1/4	2-5/8	3/8	3/4	1-1/8
QGFL26B2	8 AWG-2/0 AWG	1-1/4	1-1/2	1/2	1/4	1-1/8
QGFL26B2T6	8 AWG-2/0 AWG	1-1/2	2-7/8	1/2	3/4	1-1/8
QGFL29B1	6 AWG-250 kcmil	1-5/8	2-5/8	1/2	1/4	1-3/8
QGFL29B1T6	6 AWG-250 kcmil	1-5/8	3-1/8	1/2	3/4	1-3/8
QGFL31B1	2 AWG-350 kcmil	1-3/4	2-7/8	1/2	1/4	1-5/8
QGFL31B1T6	2 AWG-350 kcmil	1-3/4	3-1/4	1/2	3/4	1-5/8
QGFL34B1	1/0 AWG-500 kcmil	2	3-1/8	1/2	1/4	1-3/4
QGFL34B1T6	1/0 AWG-500 kcmil	2	3-5/8	1/2	3/4	1-3/4
QGFL39B1	350 kcmil-750 kcmil	2-1/4	3-1/4	1/2	1/4	1-3/4
QGFL39B1T6	350 kcmil-750 kcmil	2-1/4	3-5/8	1/2	3/4	1-3/4
QGFL44B1	750 kcmil-1000 kcmil	2-1/4	3-3/8	1/2	1/4	2-1/8
QGFL44B1T6	750 kcmil-1000 kcmil	2-1/4	4-1/8	1/2	3/4	2-1/8
QGFL46B1	1000 kcmil-1500 kcmil	2-1/4	4	1/2	1/4	2-1/2
QGFL46B1T6	1000 kcmil-1500 kcmil	2-1/4	4-1/2	1/2	3/4	2-1/2
QGFL48B1	1500 kcmil-2000 kcmil	2-1/4	4-3/4	1/2	1/4	3

Table of Contents - Copper End Bells



Type CB Copper Pipe

C-123



Type LB Copper Pipe

C-124



**TYPE CB
ENDBELLS**

For Use On COPPER TUBE

End bell for copper tube.

Material: Copper Alloy

Hardware: DURIMUM™ Silicon Bronze

Notes :

- Please contact factory for other sizes, combinations and availability

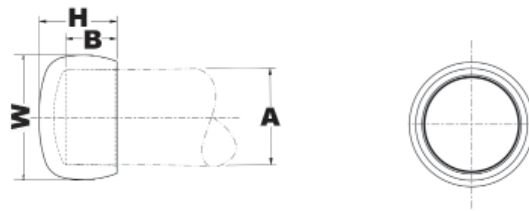

Catalog Number	A - Copper Pipe (Std or EH)	B	H	W
CB15	1 IPS	.94	1.25	1.75
CB16	1 1/4 IPS	1.19	1.50	2.13
CB17	1 1/2 IPS	1.31	1.69	2.50
CB18	2 IPS	1.44	1.94	3.00
CB19	2 1/2 IPS	1.63	2.25	3.56
CB20	3 IPS	1.88	2.63	4.25
CB22	4 IPS	2.13	3.00	5.19

**TYPE LB
END CAPS**

For Use On COPPER TUBE

End cap for copper tube.

Material: Copper Alloy

Hardware: DURIMUM™ Silicon Bronze

Notes :

- Please contact factory for other sizes, combinations and availability

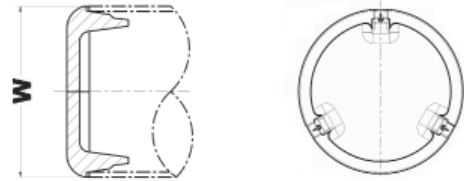

Fig. 1

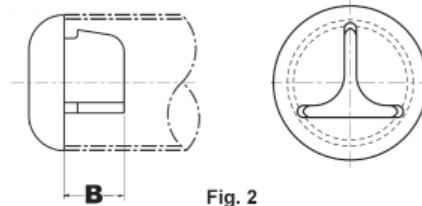

Fig. 2

Catalog Number	Fig:	Pipe Conductor	B	W
LB14	1	3/4 IPS	.38	1.05
LB15	1	1 IPS	.38	1.32
LB16	2	1 1/4 IPS	.44	1.66
LB17	2	1 1/2 IPS	.50	1.90
LB18	2	2 IPS	.56	2.38
LB19	2	2 1/2 IPS	.75	2.88
LB20	2	3 IPS	1.00	3.56
LB22	2	4 IPS	1.38	4.50
LB55	1	1 IPS	.38	1.32
LB57	2	1 1/2 IPS	.50	1.90
LB58	2	2 IPS	.56	2.38
LB59	2	2 1/2 IPS	.75	2.88
LB92	2	4 IPS	1.38	4.50

Table of Contents - Aluminum Bolted Terminals

	Type NAR Cable to Pad	A-3
	Type NAR 90/45 Cable to Angled Pad	A-5
	Type NN2AR 2 Cables to Pad	A-7
	Type NN2AR 45/90 2 Cables to Angled Pad	A-8
	Type NN3AR 3 Cables to Pad	A-9
	Type NDXR Cable to Pad	A-10
	Type NA-A Pipe to Pad	A-11
	Type NA-A 45/90 Cable to Angled Pad	A-13
	Type NAC-A Pipe to Centerline Pad	A-14
	Type XAA Expansion Pipe to Pad (With Guide)	A-16
	Type XALA Expansion Pipe to Pad (No Guide)	A-19
	Type SNA-S3 Cable to Pad	A-20
	Type SNA Cable to Pad	A-21

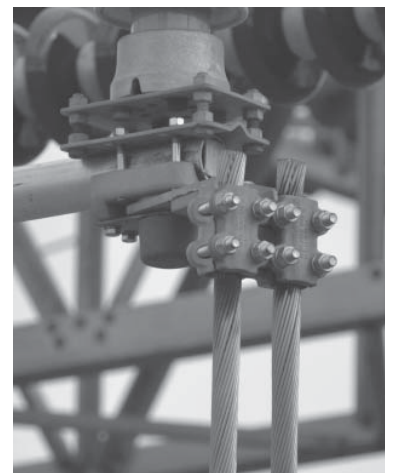
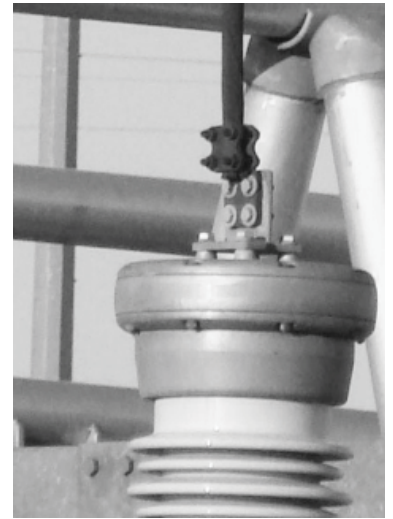

Table of Contents - Aluminum Bolted Terminals (continued)

	Type SNA-S7 Cable to Pad	A-22
	Type SN2A-S3 2 Cable to Pad	A-23
	Type SNN2A-S3 2 Cables to Pad	A-24
	Type SN2A 2 Cables to Pad	A-25
	Type SN2A-S7 2 Cables to Pad	A-26
	Type SNN2A 2 Cables to Pad	A-27
	Type SNA	A-28
	Type SNAC Cable or Pipe to Pad	A-29
	Type SXA Expansion Pipe to Pad	A-30
	Type SF2A Transformer Terminal	A-31
	Type SF3A Trifurcating Terminal	A-32
	Type S2GBPA Rigid Spacer Terminal	A-33
	Type S2GBPA-B2 Rigid Spacer Terminal	A-34
	Type S2GBPA-B4 Rigid Spacer Terminal	A-35



**TYPE NAR
TERMINAL**

For Use On CABLE TO PAD

Aluminum alloy bolted type terminal for joining aluminum cable to copper or aluminum pads. Drilling in pad conforms to NEMA Standards. PENETROX™ joint compound recommended on contact surfaces.



Material: Aluminum Alloy
Hardware: Aluminum Hardware

Notes :

- Properly proportioned to minimize conductor corrosion due to galvanic action. When properly used, this item does not require use of bimetallic plates. Please ask BURNDY® Technical Support for recommendations
- PENETROX™ A joint compound is recommended on contact surfaces
- Please contact factory for other sizes, combinations and availability
- One-wrench installation.

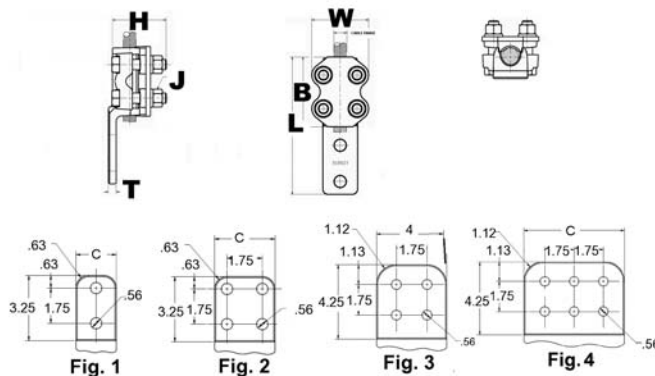

Catalog Number	Fig. #	Aluminum Stranded	Aluminum ACSR	B	J Dia.	L	H	C	T	W
NAR25A2N	1	4 AWG-1/0 AWG	4 (6/1) Swan AWG-1/0 (6/1) Raven AWG	2.00	1/2	5.10	2.72	1.25	0.31	2.28
NAR26A2N	1	#6 Str -2/0 Str.	6 (6/1) Turkey AWG-1/0 (6/1) Raven AWG	2.75	1/2	6.00	2.38	1.50	0.38	2.25
NAR29A2N	2	1/0 AWG-250 kcmil	1/0 (6/1) Raven AWG-4/0 (6/1) Penquin AWG	2.75	1/2	6.06	2.75	1.38	0.31	2.50
NAR29A4N	2			2.88	1/2	6.06	2.75	3.00	0.31	3.00
NAR32A2N	2	250 kcmil-400 kcmil	4/0 (6/1) Penquin AWG-397.5 (30/7) Larkspur kcmil	3.00	1/2	6.31	2.88	1.63	0.38	2.63
NAR32A44N	3		4/0 (6/1) Penquin AWG-397.5 (18/1) Chickadee kcmil	3.00	1/2	6.31	2.88	4.00	0.31	2.63
NAR32A4N	2		4/0 (6/1) Penquin AWG-397.5 (30/7) Larkspur kcmil	3.00	1/2	6.31	2.88	3.00	0.38	3.00
NAR32ACG2	2			3.00	1/2	6.37	2.61	3.12	.38	2.64
NAR36A2N	2	350 kcmil-600 kcmil	336.4 (30/7) Oriole kcmil-477. (30/7) Hen kcmil	3.25	1/2	6.63	2.81	1.69	0.38	2.75
NAR36A44N	3		336.4 (18/1) Merlin kcmil-477. (30/7) Hen kcmil	3.38	1/2	7.82	2.62	4.00	0.38	2.74
NAR36A4N	2		336.4 (30/7) Oriole kcmil-477. (30/7) Hen kcmil	3.25	1/2	6.63	2.81	3.00	0.38	3.00
NAR42A2N	1	600 kcmil-900 kcmil	477. (30/7) Hen kcmil-795 (30/19) Mallard kcmil	3.50	1/2	6.81	3.31	2.00	0.50	3.00
NAR42A44N	3			3.50	1/2	6.81	3.31	4.00	0.50	4.00
NAR42A4N	2			3.50	1/2	6.81	3.31	3.00	0.50	3.00

TYPE NAR
TERMINAL (Continued)

For Use On CABLE TO PAD



Catalog Number	Fig. #	Aluminum Stranded	Aluminum ACSR	B	J Dia.	L	H	C	T	W
NAR45A2N	1	900 kcmil-1250 kcmil	715.5 (30/19) Redwing kcmil- 1113 (54/19) Finch kcmil	2.63	1/2	7.12	3.31	2.63	0.50	3.20
NAR45A44N	3			3.75	1/2	7.06	3.31	4.00	0.50	4.00
NAR45A4N	2			3.75	1/2	7.12	3.31	3.00	0.50	3.20
NAR46A2N	1	1250 kcmil-1600 kcmil	1113 (54/19) Finch kcmil- 1431 (54/19) Plover kcmil	4.38	5/8	7.69	3.69	2.75	0.56	3.75
NAR46A44N	3			4.38	5/8	7.69	3.69	4.00	0.56	4.00
NAR46A4N	2			4.38	5/8	7.69	3.69	3.00	0.56	3.75
NAR486A44N	3	2000 kcmil-2500 kcmil	N/A	4.62	5/8	7.94	4.19	4.00	0.75	4.12
NAR48A2N	1	1500 kcmil-2000 kcmil	1272 (54/19) Pheasant kcmil- 1780 (54/19) kcmil	4.50	5/8	7.88	3.94	2.75	0.69	3.88
NAR48A44N	3			4.50	5/8	7.88	3.94	4.00	0.69	4.00
NAR48A4N	2			4.50	5/8	7.88	3.94	3.00	0.69	3.88
NAR495A46N	4	2500 kcmil-3500 kcmil	N/A	5.25	5/8	11.50	4.88	4.00	0.88	4.40
NAR495A66N	4			5.25	5/8	9.81	4.63	6.00	0.91	6.00

**TYPE NAR 90/45°
TERMINAL**

For Use On CABLE TO ANGLE
PAD

Aluminum alloy bolted type terminal for joining aluminum cable to copper or aluminum pads. Drilling in pad conforms to NEMA Standards. PENETROX™ joint compound recommended on contact surfaces.

Material: Aluminum Alloy
Hardware: Aluminum Hardware

Notes :

- Properly proportioned to minimize conductor corrosion due to galvanic action. When properly used, this item does not require use of bimetallic plates. Please ask BURNDY® Technical Support for recommendations
- PENETROX™ A joint compound is recommended on contact surfaces
- Please contact factory for other sizes, combinations and availability
- One-wrench installation.

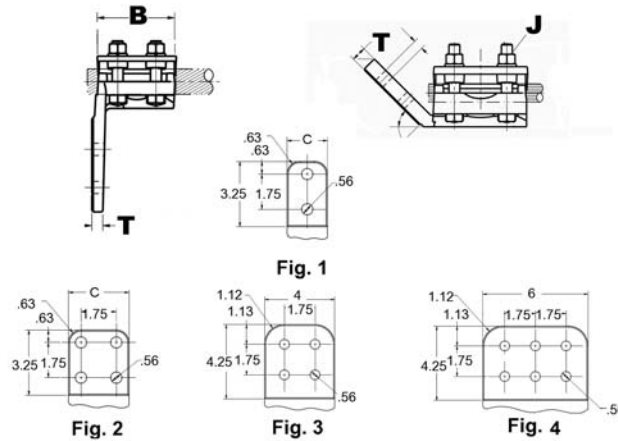

Catalog Number	Aluminum Stranded	Aluminum ACSR	Pad Angle	Fig. #	C	B	J Dia.	T
NAR25A2N90	4 AWG-1/0 AWG	4 (6/1) Swan AWG- 1/0 (6/1) Raven AWG	90°	2	1.25	1.88	1/2	0.38
NAR29A2N90	1/0 AWG-250 kcmil	1/0 (6/1) Raven AWG- 4/0 (6/1) Penquin AWG	90°	2	1.62	2.75	1/2	0.38
NAR29A4N90			90°	2	3.00	2.75	1/2	0.38
NAR32A2N45	250 kcmil-400 kcmil	4/0 (6/1) Penquin AWG- 397.5 (30/7) Larkspur kcmil	45°	1	1.62	3.00	1/2	0.38
NAR32A2N90			90°	1	1.63	3.00	1/2	0.38
NAR32A4N45			45°	2	3.00	3.00	1/2	0.38
NAR32A4N90			90°	2	3.00	3.00	1/2	0.38
NAR36A2N45	350 kcmil-600 kcmil	336.4 (18/1) Merlin kcmil- 477. (30/7) Hen kcmil	45°	1	2.68	3.25	1/2	0.38
NAR36A2N90			90°	2	1.75	3.25	1/2	0.38
NAR36A44N90		336.4 (30/7) Oriole kcmil- 477. (30/7) Hen kcmil	90°	3	4.00	3.25	1/2	0.38
NAR36A4N45			45°	2	3.00	3.25	1/2	0.38
NAR36A4N90			90°	2	3.00	3.25	1/2	0.38

**TYPE NAR 90/45°
TERMINAL (Continued)**

For Use On CABLE TO ANGLE
PAD



Catalog Number	Aluminum Stranded	Aluminum ACSR	Pad Angle	Fig. #	C	B	J Dia.	T
NAR42A2N45	600 kcmil-900 kcmil	477. (30/7) Hen kcmil- 795 (30/19) Mallard kcmil	45°	1	3.00	3.50	1/2	0.50
NAR42A2N90			90°	2	2.00	3.50	1/2	0.50
NAR42A44N90GS			90°	3	4.00	3.50	1/2	0.50
NAR42A4N45			45°	2	3.00	3.50	1/2	0.50
NAR42A4N90			90°	2	3.00	3.50	1/2	0.50
NAR45A44N90	900 kcmil-1250 kcmil	715.5 (54/7) Crow kcmil- 1113 (54/19) Finch kcmil	90°	2	4.00	3.75	1/2	0.50
NAR45A4N135		715.5 (30/19) Redwing kcmil- 1113 (54/19) Finch kcmil	135°	2	3.00	3.75	1/2	0.50
NAR45A4N45		715.5 (54/7) Crow kcmil- 1113 (54/19) Finch kcmil	45°	1	2.62	3.75	1/2	0.50
NAR45A4N90		715.5 (30/19) Redwing kcmil- 1113 (54/19) Finch kcmil	90°	2	3.00	3.75	1/2	0.50
NAR46A2N90	1250 kcmil-1600 kcmil	1113 (54/19) Finch kcmil- 1431 (54/19) Plover kcmil	90°	2	2.75	4.38	5/8	0.56
NAR46A44N45			45°	3	4.00	4.38	5/8	0.56
NAR46A44N90			90°	2	4.00	4.38	5/8	0.62
NAR46A4N45			45°	1	2.75	4.38	5/8	0.56
NAR46A4N90			90°	2	3.00	4.38	5/8	0.56
NAR486A44N90	2000 kcmil-2500 kcmil	N/A	90°	3	4.00	4.62	5/8	0.75
NAR48A44N90	1500 kcmil-2000 kcmil	1272 (54/19) Pheasant kcmil- 1780 (54/19) kcmil	90°	3	4.00	4.50	5/8	0.69
NAR48A4N45			45°	1	2.75	4.50	5/8	.75
NAR48A4N90			90°	2	3.00	4.50	5/8	0.75
NAR495A46N45	2500 kcmil-3500 kcmil	N/A	45°	4	4.00	5.25	5/8	0.88
NAR495A46N90			90°	4	4.00	5.25	5/8	0.88
NAR495A66N45			45°	4	6.00	5.25	5/8	0.88
NAR495A66N90			90°	2	6.00	5.25	5/8	0.88

**TYPE NN2AR
TERMINAL**

For Use On (2) CABLES TO
PAD

Aluminum alloy terminal for joining a wide range of (2) aluminum cables with specific spacing to copper or aluminum pad. Drilling in pad conforms to NEMA standards.



Material: Aluminum Alloy
Hardware: Aluminum Hardware

Notes :

- Properly proportioned to minimize conductor corrosion due to galvanic action. When properly used, this item does not require use of bimetallic plates. Please ask BURNDY® Technical Support for recommendations
- PENETROX™ A joint compound is recommended on contact surfaces
- Please contact factory for other sizes, combinations and availability
- One-wrench installation

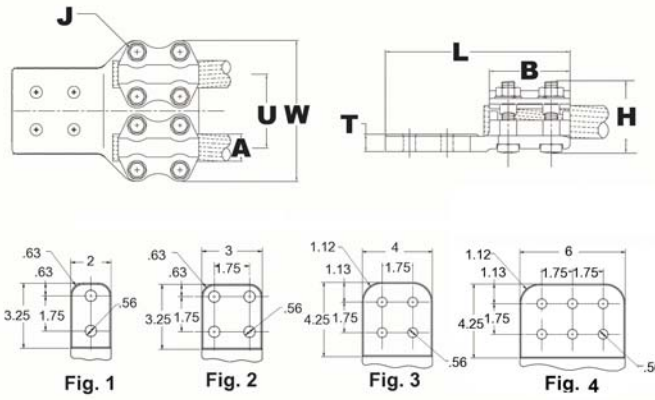

Catalog Number	Fig. #	Aluminum Stranded	Aluminum ACSR	B	J Dia.	U	L	H	T	W
NN2AR36A2N	1	350 kcmil-600 kcmil	336.4 (18/1) Merlin kcmil-	3.25	1/2	3.00	6.75	2.65	0.59	5.73
NN2AR36A4N	2		477.0 (18/1) Pelican kcmil	3.25	1/2	3.00	6.50	2.65	0.38	5.73
NN2AR42A4N	2	600 kcmil-900 kcmil	477.0 (18/1) Pelican kcmil- 795 (54/7) Condor kcmil	3.50	1/2	3.25	6.81	3.31	0.55	6.25
NN2AR45A44N	3	900 kcmil-1250 kcmil	715.5 (54/7) Crow kcmil-	3.75	1/2	3.45	8.06	3.31	0.81	6.65
NN2AR45A4N	2		1113 (54/19) Finch kcmil	3.75	1/2	3.45	7.09	3.31	0.81	6.65
NN2AR46A44N	3	1250 kcmil-1600 kcmil	1113 (54/19) Finch kcmil-	4.38	5/8	4.00	8.90	3.71	0.75	7.72
NN2AR46A4N	2		1431 (54/19) Plover kcmil	4.38	5/8	3.57	8.94	3.69	1.00	6.88
NN2AR486A44N	3	2000 kcmil-2500 kcmil	N/A	4.75	5/8	4.38	9.40	4.25	0.88	8.45
NN2AR486A66N	4			4.75	5/8	4.38	9.46	4.25	0.88	8.45
NN2AR48A44N	3	1500 kcmil-2000 kcmil	1272 (54/19) Pheasant kcmil- 1780 (54/19) kcmil	4.50	5/8	4.19	9.00	3.71	0.75	8.01
NN2AR48A4N	2			4.50	5/8	4.12	8.14	3.83	1.00	8.50
NN2AR48A66N	4			4.50	5/8	4.19	9.00	3.71	0.75	8.01

**TYPE NN2AR 45°/90°
TERMINAL**

For Use On (2) CABLES TO
ANGLE PAD

Aluminum alloy terminal for joining a wide range of (2) aluminum cables with specific spacing to copper or aluminum pad. Drilling in pad conforms to NEMA standards.



Material: Aluminum Alloy
Hardware: Aluminum Hardware

Notes :

- Properly proportioned to minimize conductor corrosion due to galvanic action. When properly used, this item does not require use of bimetallic plates. Please ask BURNDY® Technical Support for recommendations
- PENETROX™ A joint compound is recommended on contact surfaces
- Please contact factory for other sizes, combinations and availability
- One-wrench installation

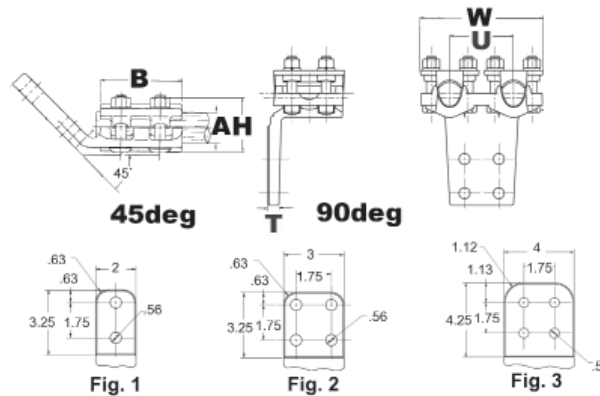

Catalog Number	Fig. #	Aluminum Stranded	Aluminum ACSR	B	Pad Angle	U	H	W
NN2AR36A4N90	2	350 kcmil-600 kcmil	336.4 (18/1) Merlin kcmil-477.0 (18/1) Pelican kcmil	3.25	90°	3.00	2.65	5.73
NN2AR42A4N45	2	600 kcmil-900 kcmil	477.0 (18/1) Pelican kcmil-795 (54/7) Condor kcmil	3.62	45°	3.25	3.11	6.26
NN2AR42A4N90	2			3.62	90°	3.26	3.91	6.26
NN2AR45A44N45	3	900 kcmil-1250 kcmil	715.5 (54/7) Crow kcmil-1113 (54/19) Finch kcmil	3.75	45°	3.45	3.31	6.25
NN2AR45A44N90	3			3.75	90°	3.45	4.64	6.59
NN2AR46A44N45	3	1250 kcmil-1600 kcmil	1113 (54/19) Finch kcmil-1431 (54/19) Plover kcmil	4.38	45°	4.03	3.83	7.72
NN2AR46A44N90	3			4.38	90°	4.03	4.93	6.88
NN2AR48A44N45	3	1500 kcmil-2000 kcmil	1272 (54/19) Pheasant kcmil-1780 (54/19) kcmil	3.75	45°	3.45	3.31	6.25
NN2AR48A44N90	3			4.62	90°	4.19	5.03	8.01
NN2AR48A4N90	2		1113 (54/19) Finch kcmil-1780 (54/19) kcmil	4.50	90°	4.12	3.71	8.00
NN2AR48A44N45L6SS	3		1272 (54/19) Pheasant kcmil-1780 (54/19) kcmil	4.50	45°	6.00	3.71	8.01

TYPE NN3AR
Bolted Terminal

For Use On (3) ALUMINUM CABLES TO PAD

Aluminum alloy terminal for joining a wide range of 3 aluminum cables to copper or aluminum pad. Drilling in pad conforms to NEMA standards. One-wrench installation.



Material: Aluminum Alloy
Hardware: Aluminum Hardware

Notes :

- Properly proportioned to minimize conductor corrosion due to galvanic action. When properly used, this item does not require use of bimetallic plates. Please ask BURNDY® Technical Support for recommendations
- PENETROX™ A joint compound is recommended on contact surfaces
- Please contact factory for other sizes, combinations and availability
- One-wrench installation.

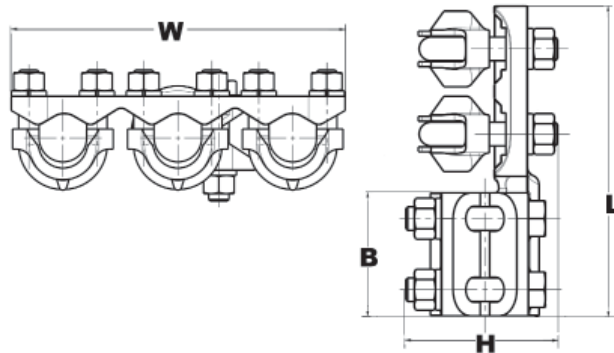

Catalog Number	Aluminum Stranded	Aluminum ACSR	B	L	H	W
NN3AR32A34N	250 kcmil-400 kcmil	4/0 (6/1) Penquin AWG- 397.5 (30/7) Larkspur kcmil	3.12	6.38	2.88	8.42
NN3AR36A34N	350 kcmil-600 kcmil	336.4 (18/1) Merlin kcmil- 477.0 (18/1) Pelican kcmil	3.25	6.50	2.65	8.73
NN3AR48A44N	1500 kcmil-2000 kcmil	1272 (54/19) Pheasant kcmil- 1780 (54/19) kcmil	4.50	9.00	3.71	12.62

TYPE NDXR
Bolted Terminals

For Use On CABLE TO FLAT

Versatile aluminum connector to join a wide variety of cables to a bar tap. The bolts are compliant with 4-hole NEMA drilling layout.

Material: Aluminum Alloy
Hardware: Aluminum Hardware

Notes :

- Properly proportioned to minimize conductor corrosion due to galvanic action. When properly used, this item does not require use of bimetallic plates. Please ask BURNDY® Technical Support for recommendations
 - PENETROX™ A joint compound is recommended on contact surfaces
- Please contact factory for other sizes, combinations and availability.

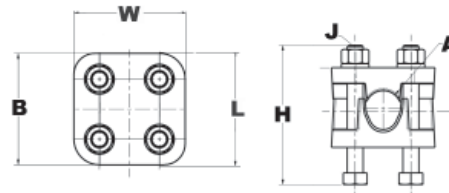

Catalog Number	Aluminum Stranded	Aluminum ACSR	B	J Dia.	L	H	W
NDXR42A	397 kcmil- 900 kcmil	300.0 (26/7) Ostrich kcmil- 795 (54/7) Condor kcmil	3.25	1/2	3.25	4.00	3.25

**TYPE NA-A
TERMINAL**

For Use On TUBE TO FLAT

Aluminum alloy terminal for joining copper or aluminum tube to copper or aluminum pad.

Material: Aluminum Alloy
Hardware: Aluminum Hardware

Notes :

- Properly proportioned to minimize conductor corrosion due to galvanic action. When properly used, this item does not require use of bimetallic plates. Please ask BURNDY® Technical Support for recommendations
- PENETROX™ A joint compound is recommended on contact surfaces
- Please contact factory for other sizes, combinations and availability
- One-wrench installation

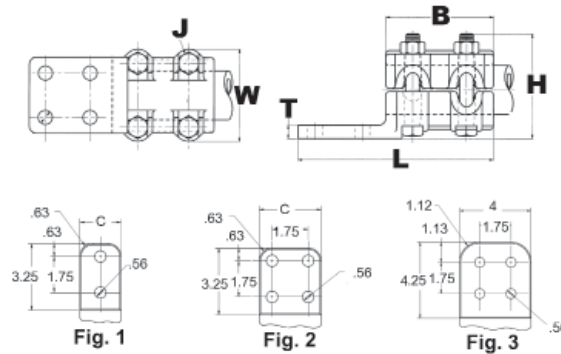

Catalog Number	Fig. #	Al tube	B	C	J Dia.	L	H	T	W
NA13A2N	2	1/2 IPS	3.00	1.50	1/2	6.25	2.88	0.38	2.58
NA14A2N	2	3/4 IPS	3.25	1.62	1/2	6.50	3.12	0.38	2.80
NA14A4N	2		3.25	4.00	1/2	6.50	3.12	0.38	2.80
NA15A2N	2	1 IPS	3.50	1.88	1/2	6.75	3.38	0.38	3.06
NA15A44N	3		3.875	4.00	1/2	6.88	3.38	0.50	3.06
NA15A4N	1		3.50	3.00	1/2	6.75	3.38	0.38	3.06
NA16A2N	2	1 1/4 IPS	3.75	2.25	1/2	7.00	3.38	0.44	3.40
NA16A4N	1		3.75	3.00	1/2	7.00	3.38	0.44	3.40
NA17A2N	2	1 1/2 IPS	4.00	2.50	1/2	7.50	3.88	0.50	3.64
NA17A34N	2		4.00	3.00	1/2	7.50	3.88	0.50	3.64
NA17A4N	1		4.00	3.00	1/2	7.50	3.88	0.50	3.64
NA18A2N	2	2 IPS	4.25	2.75	5/8	7.50	4.47	0.50	4.50
NA18A34N	1		4.25	3.00	5/8	7.50	4.47	0.50	4.50
NA18A44N	1		4.25	4.00	5/8	8.50	4.47	0.50	4.50
NA18A4N	1		4.25	3.12	5/8	7.50	4.47	0.50	4.50
NA19A2N	1	2 1/2 IPS	4.50	3.25	5/8	7.75	4.97	0.69	5.00
NA19A34N	2		4.50	3.00	5/8	7.75	4.97	0.69	5.00
NA19A44N	3		4.50	4.00	5/8	7.75	4.97	0.75	5.00
NA19A4N	1		4.50	3.75	5/8	7.75	4.97	0.69	5.00

TYPE NA-A (Continued)

For Use On TUBE TO FLAT



Catalog Number	Fig. #	Al tube	B	C	J Dia.	L	H	T	W
NA20A2N	2	3 IPS	5.00	4.38	5/8	8.31	5.47	0.69	5.62
NA20A34N	1		5.00	3.00	5/8	8.31	5.47	0.69	5.63
NA20A44N	1		5.00	4.00	5/8	8.56	5.47	0.69	5.62
NA20A4N	1		5.00	4.38	5/8	8.31	5.47	0.69	5.62
NA21A34N	2	3 1/2 IPS	5.50	3.00	5/8	8.81	5.62	0.81	6.14
NA21A4N	1		5.50	4.75	5/8	8.81	5.62	0.81	6.14
NA22A34N	2	4 IPS	6.00	3.00	5/8	9.31	6.22	0.81	6.62
NA22A44N	3		6.00	4.00	5/8	10.75	6.22	0.81	6.63
NA22A4N	1		6.00	5.25	5/8	9.31	6.22	0.81	6.62

**TYPE NA-A 45°/90°
TERMINAL**

For Use On TUBE TO ANGLE
PAD

Aluminum alloy terminal for joining
copper or aluminum tube to copper or
aluminum pad.

Material: Aluminum Alloy
Hardware: Aluminum Hardware

Notes :

- Properly proportioned to minimize conductor corrosion due to galvanic action. When properly used, this item does not require use of bimetallic plates. Please ask BURNDY® Technical Support for recommendations
- PENETROX™ A joint compound is recommended on contact surfaces
- Please contact factory for other sizes, combinations and availability
- One-wrench installation

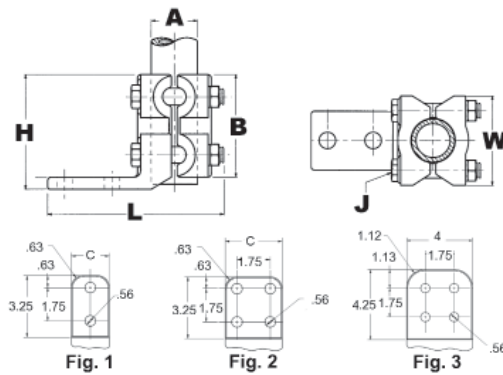

Catalog Number	Fig. #	Al tube	B	C	Pad Angle	J Dia.	L	H	W
NA15A34N90	2	1 IPS	3.50	3.00	90°	1/2	3.88	6.50	3.06
NA15A44N90	3		3.50	4.00	90°	1/2	6.41	3.88	3.12
NA16A2N90	1	1 1/4 IPS	3.75	2.25	90°	1/2	4.19	6.53	3.41
NA18A2N90	1	2 IPS	4.25	2.75	90°	5/8	5.00	7.50	4.50
NA18A4N45	2		4.25	3.00	45°	5/8	7.35	4.47	4.50
NA18A4N90	2		4.25	3.12	90°	5/8	5.00	7.50	4.50
NA19A2N90	1	2 1/2 IPS	4.50	3.25	90°	5/8	9.71	5.25	5.00
NA19A44N90	3		4.50	4.00	90°	5/8	9.71	5.25	5.00
NA19A4N90	1		4.50	3.75	90°	5/8	5.38	7.75	5.00
NA20A4N90	2	3 IPS	5.00	4.38	90°	5/8	5.69	8.69	5.62
NA21A4N90	2	3 1/2 IPS	5.50	4.75	90°	5/8	7.00	8.81	6.14
NA22A34N90	2	4 IPS	6.00	3.00	90°	5/8	9.00	8.56	6.62
NA22A4N90GS	2		6.00	5.25	90°	5/8	6.81	9.00	6.62

TYPE NAC-A BOLTED TERMINAL

For Use On PIPE TO
CENTERLINE PAD

Aluminum alloy bolted terminal for joining aluminum tube to copper or aluminum centered pad. Drilling in pad conforms to NEMA standards.

Material: Aluminum Alloy
Hardware: Aluminum Hardware

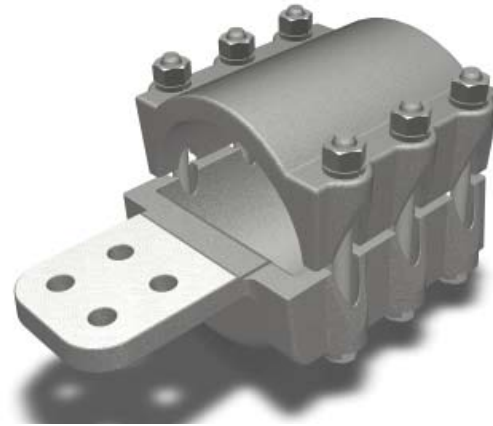

Notes :

- Properly proportioned to minimize conductor corrosion due to galvanic action. When properly used, this item does not require use of bimetallic plates. Please ask BURNDY® Technical Support for recommendations
- PENETROX™ A joint compound is recommended on contact surfaces
- Please contact factory for other sizes, combinations and availability
- One-wrench installation

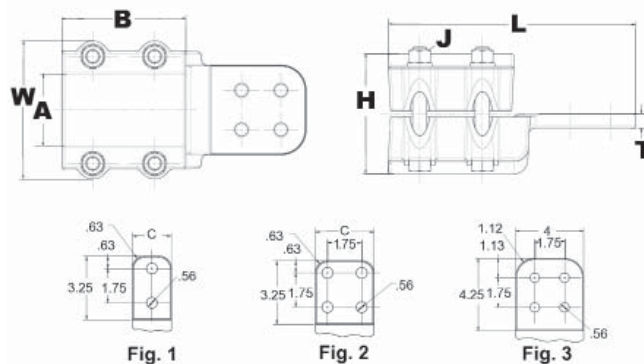

Catalog Number	Fig. #	Al tube	B	C	J Dia.	L	H	T	W
NAC15A2N	1	1 IPS	3.50	1.88	1/2	7.19	3.31	0.38	3.06
NAC15A34N	2		3.50	3.00	1/2	7.57	3.31	0.38	3.06
NAC15A4N	1		3.50	3.00	1/2	7.19	3.31	0.38	3.06
NAC17A2N	1	1 1/2 IPS	3.25	1.62	1/2	7.19	3.12	0.38	2.81
NAC17A34N	1		4.00	3.00	1/2	8.38	3.81	0.44	3.64
NAC17A44N	1		4.00	4.00	1/2	8.44	3.81	0.44	3.64
NAC18A2N	1	2 IPS	4.25	2.75	5/8	8.38	4.47	0.50	4.50
NAC18A34N	1		4.25	3.00	5/8	8.66	4.39	0.50	4.50
NAC18A44N	1		4.25	4.00	5/8	8.72	4.39	0.50	4.50
NAC18A4N	2		4.25	3.12	5/8	8.38	4.47	0.50	4.50
NAC1934N	2	2 1/2 IPS	2.69	3.00	1/2	6.53	2.66	0.75	5.12
NAC194N	2		4.50	3.75	5/8	8.62	4.97	0.69	5.00
NAC19A34N	1		4.50	3.00	5/8	8.91	4.89	0.56	5.00
NAC19A44N	1		4.50	4.00	5/8	8.97	4.89	0.56	5.00
NAC204N	1	3 IPS	5.00	4.38	5/8	9.80	5.50	0.75	5.62
NAC20A34N	1		5.00	3.00	5/8	9.44	5.42	0.62	5.62
NAC20A44N	1		5.00	4.00	5/8	9.50	5.42	0.62	5.02
NAC21A34N	1	3 1/2 IPS	5.50	3.00	5/8	9.94	5.56	0.62	6.14
NAC21A44N	1		5.50	4.00	5/8	10.00	5.56	0.62	6.14

**TYPE NAC-A
BOLTED TERMINAL**

(Continued)

For Use On PIPE TO
CENTERLINE PAD

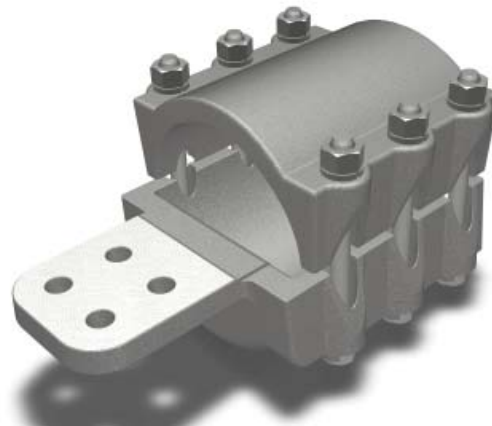

Catalog Number	Fig. #	Al tube	B	C	J Dia.	L	H	T	W
NAC22A34N	1	4 IPS	6.00	3.00	5/8	10.44	6.17	0.75	6.62
NAC22A44N	1		6.00	4.00	5/8	10.50	6.17	0.75	6.62
NAC22A4N	2		6.00	5.25	5/8	10.38	6.25	0.88	6.62
NAC22A66N	—		6.25	6.00	5/8	11.26	5.50	0.88	6.63
NAC24A44N	2	5 IPS	7.00	11.57	5/8	11.57	6.97	0.75	7.70
NAC24A4N	2		7.00	6.50	5/8	11.50	7.00	0.86	7.69
NAC86A44N	2	6 IPS	8.00	4.00	5/8	12.57	8.50	1.00	8.76

TYPE XAA EXPANSION TERMINAL

For Use On EXPANSION TUBE TO FLAT

Aluminum alloy expansion connector for joining tube to copper or aluminum bar or equipment pads. Flexible aluminum straps allow for longitudinal or lateral movement and carries full current load of the joint. PENETROX™ joint compound recommended on contact surfaces. Pad contact surface is on centerline of conductor.

Material: Aluminum Alloy
Hardware: Aluminum Hardware

Notes :

- PENETROX™ A joint compound is recommended on contact surfaces
- One side of pad finished on centerline of tubing. For finished pads on both sides add suffix "-Q" to catalog number.

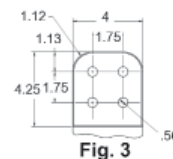
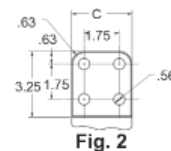
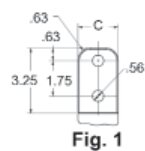
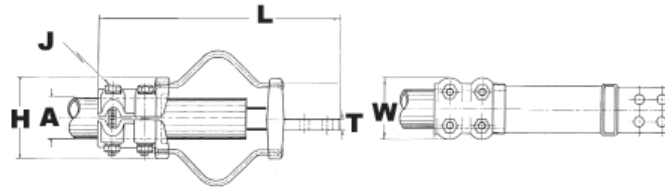

Catalog Number	Fig. #	Al tube Schd 40	Al tube Schd 80	C	J Dia.	L	H	T	W
XA15A2N	1	1 IPS	N/A	1.88	1/2	13.19	3.70	0.38	3.06
XA15A4N	2			3.00	1/2	13.19	3.70	0.38	3.06
XA16A2N	1	1 1/4 IPS		2.25	1/2	13.62	4.06	0.44	3.41
XA16A4N	2			3.00	1/2	13.62	4.00	0.44	3.41
XA17A2N	1	1 1/2 IPS		2.50	1/2	14.83	4.50	0.50	3.64
XA17A34N	2			3.00	1/2	11.59	3.87	0.50	3.64
XA17A4N	2	3.00		1/2	14.83	4.50	0.50	3.64	
XA18A2N	1	2 IPS		2.75	5/8	15.50	5.26	0.50	4.50
XA18A34N	2			3.00	5/8	12.17	4.72	0.50	4.50
XA18A4N	2	3.12		5/8	15.50	5.26	0.50	4.50	
XA19A2N	1	2 1/2 IPS		3.75	5/8	16.94	5.72	0.69	5.00
XA19A34N	2			3.00	5/8	13.26	5.10	0.69	3.74
XA19A44N	3		4.00	5/8	14.32	5.10	0.69	5.00	
XA19A4N	2		3.75	5/8	16.94	5.72	0.69	5.00	
XA20A2N	1	3 IPS	4.38	5/8	18.52	6.80	0.69	5.62	
XA20A44N	3		4.00	5/8	9.28	4.75	0.69	5.62	
XA20A4N	2		4.38	5/8	18.52	6.80	0.69	5.62	
XA21A44N	3	3 1/2 IPS	4.00	5/8	21.14	5.57	0.88	6.13	
XA21A4N	2		4.75	5/8	20.00	7.60	0.81	6.12	

**TYPE XAA
EXPANSION TERMINAL**

(Continued)

For Use On EXPANSION TUBE
TO FLAT



Catalog Number	Fig. #	Al tube Schd 40	Al tube Schd 80	C	J Dia.	L	H	T	W
XA22A44N	3	4 IPS	N/A	4.00	5/8	21.00	8.48	0.81	6.62
XA22A4N	2			5.25	5/8	21.00	8.16	0.81	6.62
XA22A66N	5			6.00	5/8	17.57	7.06	0.81	5.71
XA24A44N	3	5 IPS		4.00	5/8	17.85	8.43	0.81	6.91
XA24A4N	2			6.50	5/8	24.15	9.74	0.81	7.69
XA59A44N	3	N/A		2 1/2 IPS	4.00	5/8	14.32	5.10	0.69
XA59A4N	2		3.75		5/8	16.94	5.90	0.69	5.00
XA91A4N	2		4.75		5/8	20.00	7.98	0.81	6.12
XA92A44N	3		4 IPS	4.00	5/8	21.00	8.16	0.81	6.62
XA92A4N	2			5.25	5/8	21.00	8.48	0.81	6.62
XA96A4NGS	2		6 IPS	7.62	5/8	26.51	11.54	0.94	8.75
XA96A66NGS	4	6.00		5/8	33.00	18.50	0.94	8.17	

TYPE XAA EXPANSION TERMINAL

For Use On EXPANSION TUBE TO FLAT

Aluminum alloy expansion connector for joining tube to copper or aluminum bar or equipment pads. Flexible aluminum straps allow for longitudinal or lateral movement and carries full current load of the joint. PENETROX™ joint compound recommended on contact surfaces. Pad contact surface is on centerline of conductor.

Material: Aluminum Alloy
Hardware: Aluminum Hardware

Notes :

- PENETROX™ A joint compound is recommended on contact surfaces
- One side of pad finished on centerline of tubing. For finished pads on both sides add suffix "-Q" to catalog number.

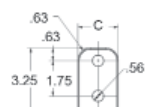
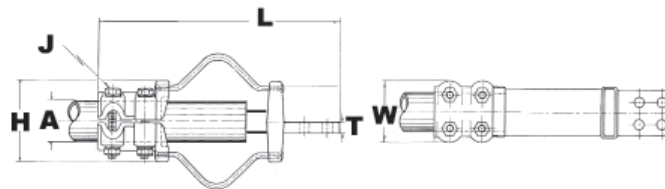

Fig. 1

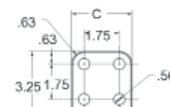

Fig. 2

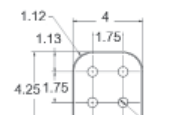

Fig. 3

Catalog Number	Fig. #	Al tube Schd 40	B	C	J Dia.	L	H	W
XA15A34NR90	2	1 IPS	3.00	3.00	3/8	12.50	4.31	3.12
XA15A44NR90	3		3.00	4.00	3/8	13.50	4.31	3.12
XA17A34NR90	2	1 1/2 IPS	3.50	3.00	1/2	14.38	6.44	4.31
XA18A34NR90	2	2 IPS	3.50	3.00	1/2	14.38	7.38	4.62
XA18A44NR90	3		3.50	4.00	1/2	15.38	7.38	4.62
XA19A34NR90	2	2 1/2 IPS	4.00	3.00	1/2	14.75	9.56	5.25
XA19A44NR90	3		4.00	4.00	1/2	15.75	9.56	5.25
XA20A44N90	3	3 IPS	4.00	4.38	5/8	15.25	7.75	6.50
XA20A4N90	1		5.00	4.38	5/8	18.52	6.80	5.62
XA21A44NR90	3	3 1/2 IPS	5.50	4.00	5/8	21.14	5.57	6.12
XA22A4N90	1	4 IPS	6.00	5.25	5/8	21.00	8.16	6.62
XA24A44NR90	3	5 IPS	4.00	4.00	5/8	18.44	8.43	6.91

TYPE XALA EXPANSION TERMINAL

For Use On EXPANSION TUBE TO PAD (NO GUIDE)

Aluminium alloy expansion terminal for joining welded bus to four hole or six hole pad. Flexible aluminum straps allow for longitudinal or lateral movement and carries full current load of the joint.

Material: Aluminum Alloy
Hardware: Aluminum Hardware

Notes :

- PENETROX™ A joint compound is recommended on contact surfaces
- One side of pad finished on centerline of tubing. For finished pads on both sides add suffix "-Q".

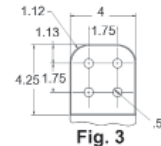
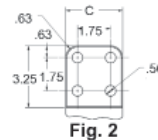
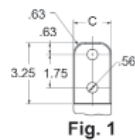
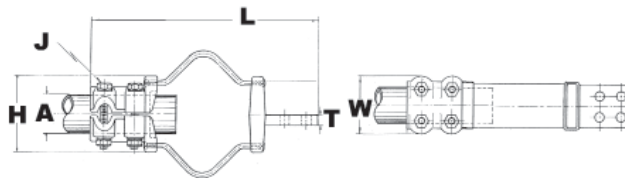

Catalog Number	Fig. #	Al tube Schd 40	Al tube Schd 80	B	C	J Dia.	L	H	T	W
XAL17A4N	1	1 1/2 IPS	N/A	4.00	3.00	1/2	14.83	4.50	0.50	3.64
XAL19A4N	1	2 1/2 IPS		4.50	3.75	5/8	16.94	5.72	0.69	5.00

**TYPE SNA-S3
BOLTED TERMINAL**

For Use On CABLE TO PAD

Aluminium alloy terminal for joining a wide range of cables to Aluminium pads. Drilling in pads conforms to NEMA standards. Pad requires STS shielding caps for EHV.

EHV RATED: SELF-SHIELDING UP TO 550 kV

Material: Aluminum Alloy
Hardware: Aluminum Hardware

Notes :

- Properly proportioned to minimize conductor corrosion due to galvanic action. When properly used, this item does not require use of bimetallic plates. Please ask BURNDY® Technical Support for recommendations
- PENETROX™ A joint compound is recommended on contact surfaces
- Please contact factory for other sizes, combinations and availability
- Use shielding caps for high voltage applications (STS family). Shielding caps may be purchased separately
- One wrench installation

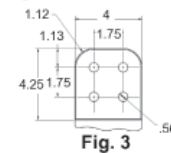
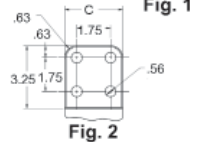
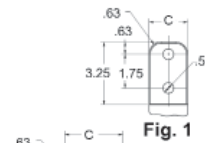
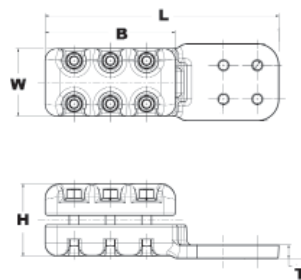

Catalog Number	Aluminum Stranded	Aluminum ACSR	Pad Angle	Fig. #	C	B	L	H	W	T
SNA41A44N45S3SS	795 kcmil	795 (54/7) Condor kcmil- 795 (30/19) Mallard kcmil	45°	3	4.00	4.88	8.46	3.46	3.00	.50
SNA41A44N90S3SS			90°	3	4.00	4.88	5.00	7.30	2.97	.50
SNA41A44NS3SS			0°	3	4.00	4.88	9.63	3.58	3.00	.50
SNA47A44N90S3	1800 kcmil	N/A	90°	3	4.00	6.75	7.47	8.50	4.28	.72
SNA47A44NS3HQ			0°	3	4.00	6.75	12.12	3.86	3.50	.69

**TYPE SNA
BOLTED TERMINAL**

For Use On CABLE TO PAD

Aluminum alloy streamlined terminal for joining aluminum cables to aluminium pads. Drilling in pads conforms to NEMA standards.

EHV RATED: SELF-SHIELDING UP TO 550 kV

Material: Aluminum Alloy

Hardware: Aluminum Hardware

Notes :

- For 45 degree pad add suffix -45 to the catalog number; for 90 degree pad add suffix -90
- To modify Hardware configuration, please add “-SS” for Stainless Steel and “-GS” for Galvanized Steel
- PENETROX™ A joint compound is recommended on contact surfaces
- Use shielding caps for high voltage applications (STS family). Shielding caps may be purchased separately
- Scratch brush connector contact surface, dry then apply an oxide inhibitor.
- PENETROX™ A can be purchased from BURNDY® in cans or plastic squeeze bottles.

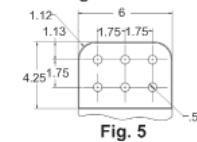
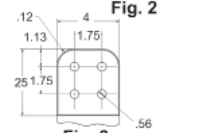
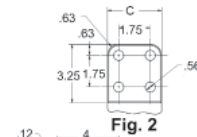
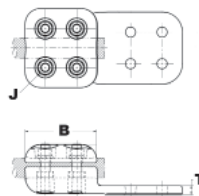

Catalog Number	Aluminum Stranded	Aluminum ACSR	Fig. #	C	B	J Dia.	T
SNA44A44N	N/A	795 (54/7) Condor kcmil- 900 (54/7) Canary kcmil	3	4.00	4.00	1/2	.50
SNA44A4N	954 kcmil	795 (54/7) Condor kcmil- 874.5 (54/7) Crane kcmil	2	3.00	4.00	1/2	.50
SNA45A4NGS	1192 kcmil-1272 kcmil	1033.5 (54/7) Curlew kcmil- 1192.5 (54/19) Grackle kcmil	2	3.00	3.75	1/2	.50
SNA46A44NGS	1590 kcmil	1272 (54/19) Pheasant kcmil-	3	4.00	4.00	1/2	.69
SNA46A4NGS		1431 (54/19) Plover kcmil	2	3.00	3.75	1/2	.56
SNA486A44N	2300 kcmil-2500 kcmil	2156 (84/19) Bluebird kcmil-	3	4.00	5.25	5/8	.83
SNA486A4N		2167 (72/7) Kiwi kcmil	2	3.00	5.00	5/8	.83
SNA48A44N	1750 kcmil-2000 kcmil	1590 (45/7) Lapwing kcmil- 1780 (84/19) Chukar kcmil	3	4.00	4.00	1/2	.69
SNA48A46NGS	N/A	2034.5 (72/7) Mockingbird kcmil	5	4.00	5.38	1/2	.62

**TYPE SNA-S7
BOLTED TERMINAL**

For Use On CABLE TO PAD

Aluminium alloy terminal for joining a wide range of cables to aluminum pads. Properly proportioned to minimize conductor corrosion due to galvanic action. Drilling in pads conforms to NEMA standards. PENETROX™ joint compound recommended on contact surfaces. **EHV RATED: SELF-SHIELDING UP TO 550 kV**



Material: Aluminum Alloy
Hardware: Aluminum Hardware

Notes :

- For 45 degree pad add suffix -45 to the catalog number; for 90 degree pad add suffix -90
- To modify Hardware configuration, please add “-SS” for Stainless Steel and “-GS” for Galvanized Steel
- PENETROX™ A joint compound is recommended on contact surfaces
- Use shielding caps for high voltage applications (STS family). Shielding caps may be purchased separately
- One wrench installation

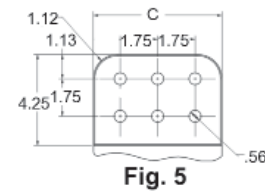
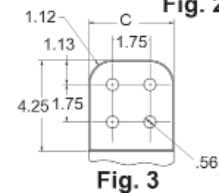
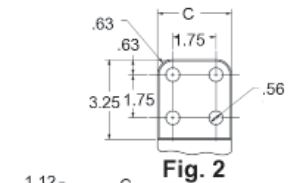
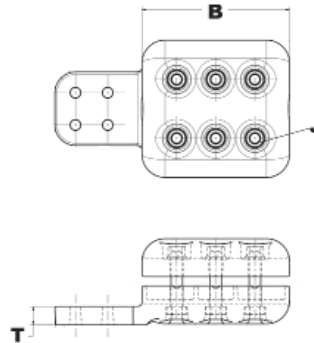

Catalog Number	Aluminum Stranded	Fig. #	C	B	J Dia.	T
SNA496A44NS7	4000 kcmil	3	4.00	8.00	5/8	1.00
SNA496A66NS7		2	6.00	8.00	5/8	1.00

**TYPE SN2A-S3
BOLTED TERMINAL**

For Use On (2) CABLES TO FLAT

Aluminum alloy terminal for joining a wide range of cable to aluminum pads. Properly proportioned to minimize conductor corrosion due to galvanic action. Drilling in pads conforms to NEMA standards. One wrench installation.

EHV RATED: SELF-SHIELDING UP TO 550 kV

Material: Aluminum Alloy
Hardware: Aluminum Hardware

Notes :

- PENETROX™ A joint compound is recommended on contact surfaces
- Please contact factory for other sizes, combinations and availability
- Use shielding caps for high voltage applications (STS family). Shielding caps may be purchased separately
- One-wrench installation.

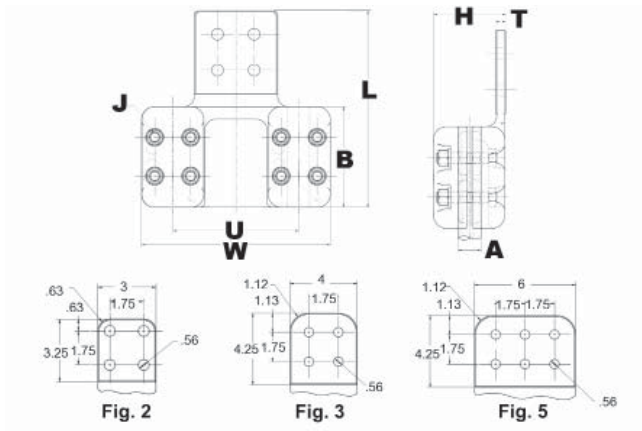

Catalog Number	Fig. #	Aluminum Stranded	B	J Dia.	U	L	H	T	W
SN2A47A44NS3HQ	3	1750 kcmil-1800 kcmil	6.75	1/2	15.00	10.18	3.74	.88	18.50

**TYPE SNN2A-S3
BOLTED TERMINAL**

For Use On (2) CABLES TO FLAT

Aluminum alloy terminal for joining a wide range of cable to aluminum pads. Properly proportioned to minimize conductor corrosion due to galvanic action. Drilling in pads conforms to NEMA standards. One wrench installation. PENETROX™ joint compound recommended on contact surfaces.

EHV RATED: SELF-SHIELDING UP TO 550 kV

Material: Aluminum Alloy
Hardware: Aluminum Hardware

Notes :

- PENETROX™ A joint compound is recommended on contact surfaces
- Please contact factory for other sizes, combinations and availability
- Use shielding caps for high voltage applications (STS family). Shielding caps may be purchased separately
- One wrench installation

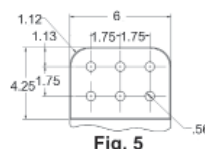
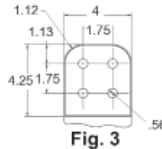
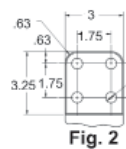
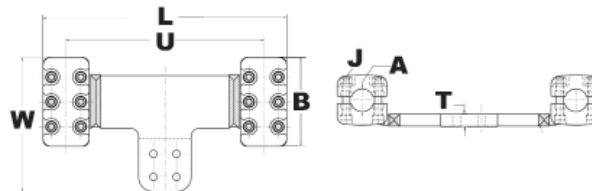
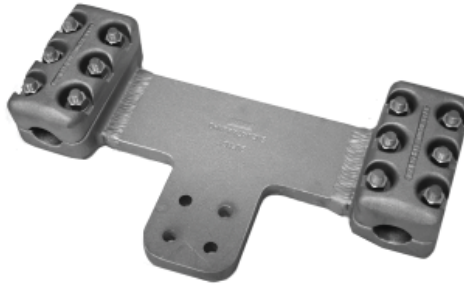

Catalog Number	Fig. #	Aluminum Stranded	B	J Dia.	U	L	H	T	W
SNN2A486A44N90S3L13GS	3	2300 kcmil	4.88	5/8	13.00	8.26	3.76	1.12	16.62
SNN2A486A44NS3L13GS	3		4.62	5/8	13.00	9.75	3.98	1.12	16.62

**TYPE SN2A
TERMINAL**

For Use On (2) CABLES TO
FLAT

Aluminum alloy streamlined terminal for joining a wide range of (2) bundle aluminum cables to flat. Properly proportioned to minimize conductor corrosion due to galvanic action. Drilling in pads conforms to NEMA standards.

EHV RATED: SELF-SHIELDING UP TO 550 kV

Material: Aluminum Alloy
Hardware: Aluminum Hardware

Notes :

- PENETROX™ A joint compound is recommended on contact surfaces
- Please contact factory for other sizes, combinations and availability
- Use shielding caps for high voltage applications (STS family). Shielding caps may be purchased separately
- One-wrench installation.

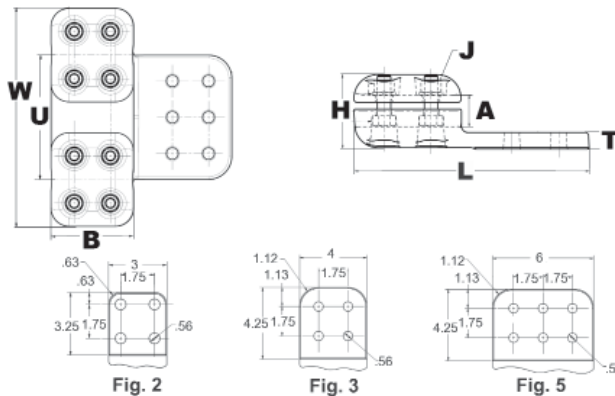

Catalog Number	Fig. #	Aluminum Stranded	Aluminum ACSR	B	J Dia.	U	L	H	T	W
SN2A445A4N	2	1033 kcmil- 1113 kcmil	954 (45/7) Rail kcmil- 1033.5 (45/7) Ortolan kcmil	3.75	1/2	4.85	7.38	2.78	.69	9.45
SN2A44A44N	3	954 kcmil	795 (54/7) Condor kcmil- 874.5 (54/7) Crane kcmil	3.75	1/2	4.77	7.38	2.74	.66	9.29
SN2A44A4N	2			3.75	1/2	4.77	7.38	2.74	.66	9.29
SN2A45A44N	3	1192 kcmil- 1272 kcmil	1033.5 (54/7) Curlew kcmil- 1192.5 (54/19) Grackle kcmil	4.88	1/2	6.00	8.62	3.28	.81	9.25
SN2A45A4N	2			3.75	1/2	5.00	7.38	2.73	.69	9.75
SN2A48A44N	3	1500 kcmil- 2000 kcmil	1272 (54/19) Pheasant kcmil- 1780 (54/19) kcmil	4.00	1/2	5.25	10.25	2.60	.81	8.75
SN2A48A4NGS	2			3.75	1/2	5.25	7.38	2.87	.81	10.25

**TYPE SN2A-S7
TERMINAL**

For Use On (2) CABLES TO
FLAT

Aluminum alloy terminal for joining a wide range of cable to aluminum pads. Properly proportioned to minimize conductor corrosion due to galvanic action. Drilling in pads conforms to NEMA standards. One wrench installation. PENETROX™ joint compound recommended on contact surfaces.

EHV RATED: SELF-SHIELDING UP TO 550 kV

Material: Aluminum Alloy
Hardware: Aluminum Hardware

Notes :

- PENETROX™ A joint compound is recommended on contact surfaces
- Please contact factory for other sizes, combinations and availability
- Use shielding caps for high voltage applications (STS family). Shielding caps may be purchased separately
- One wrench installation

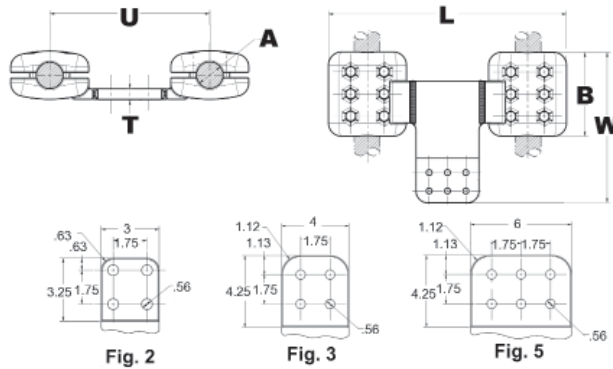
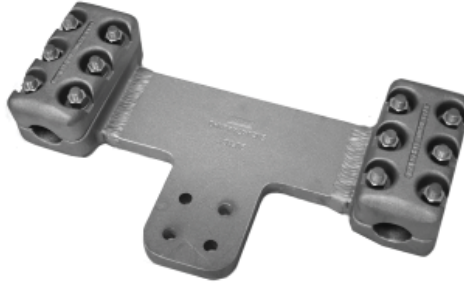

Catalog Number	Fig. #	Aluminum Stranded	Aluminum ACSR	B	J Dia.	U	L	H	T	W
SN2A496A44NS7HQ	3	4000 kcmil	N/A	8.00	5/8	15.28	14.35	4.65	1.03	22.72
SN2A496A66NS7HQ	5			8.00	5/8	15.28	14.35	4.65	1.03	22.72

**TYPE SNN2A
TERMINAL**

For Use On (2) CABLES TO
FLAT

Aluminum alloy streamlined terminal for joining a wide range of (2) bundle aluminum cables to flat. Properly proportioned to minimize conductor corrosion due to galvanic action. Drilling in pads conforms to NEMA standards.

EHV RATED: SELF-SHIELDING UP TO 550 kV

Material: Aluminum Alloy
Hardware: Aluminum Hardware

Notes :

- PENETROX™ A joint compound is recommended on contact surfaces
- Please contact factory for other sizes, combinations and availability
- Use shielding caps for high voltage applications (STS family). Shielding caps may be purchased separately
- One wrench installation.

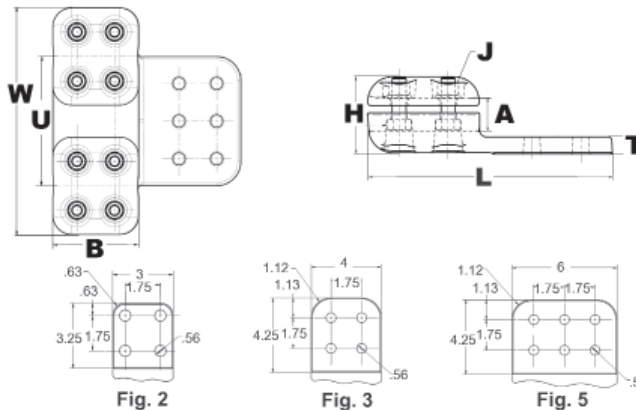

Catalog Number	Fig. #	Aluminum Stranded	Aluminum ACSR	B	J Dia.	U	L	H	T	W
SNN2A44A44N	3	900 kcmil- 1000 kcmil	795 (54/7) Condor kcmil- 874.5 (54/7) Crane kcmil	4.00	1/2	4.77	8.74	2.77	.62	9.28
SNN2A44A66NL6	5			4.00	1/2	6.00	8.74	2.77	.62	10.51
SNN2A46A66NL13GS	5	N/A	1272 (54/19) Pheasant kcmil	7.25	1/2	13.00	11.25	3.46	.88	18.62
SNN2A48A66NL13GS	5	2000 kcmil	N/A	7.25	1/2	13.00	11.25	3.46	.88	18.62

**TYPE SNA
TERMINAL**

For Use On TUBE TO PAD

Aluminium alloy terminal for joining a wide range of tube to aluminum pads. Properly proportioned to minimize conductor corrosion due to galvanic action. Drilling in pads conforms to NEMA standards. One wrench installation. PENETROX™ joint compound recommended on contact surfaces.

EHV RATED: SELF-SHIELDING UP TO 550 kV

Material: Aluminum Alloy
Hardware: Aluminum Hardware

Notes :

- PENETROX™ A joint compound is recommended on contact surfaces
- Scratch brush connector contact, surface dry then apply an oxide inhibitor. We recommend the BURNDY® joint compound PENETROX™ A, which can be purchased in cans, tubs and plastic squeeze bottles
- Use shielding caps for high voltage applications (STS family). Shielding caps may be purchased separately
- Please contact factory for other sizes, combinations and availability.

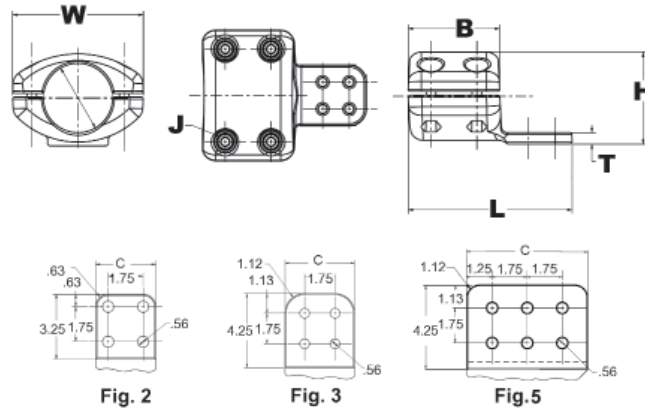

Catalog Number	Al tube	B	C	J Dia.	L	H	T	W
SNA22ACG2	4 IPS	6.00	5.25	5/8	10.38	5.94	.81	6.75
SNA86A4N	6 IPS	7.75	6.00	5/8	12.65	8.00	1.19	10.75

**TYPE SNAC
TERMINAL**

For Use On CABLE OR PIPE
TO CENTERLINE PAD

Aluminum alloy terminal for joining a wide range of cable or tube to aluminum or copper centerline pads. Drilling in pads conforms to NEMA standards.

EHV RATED: SELF-SHIELDING UP TO 550 kV

Material: Aluminum Alloy
Hardware: Aluminum Hardware

Notes :

- Properly proportioned to minimize conductor corrosion due to galvanic action. When properly used, this item does not require use of bimetallic plates. Please ask BURNDY® Technical Support for recommendations
- PENETROX™ A joint compound is recommended on contact surfaces
- Please contact factory for other sizes, combinations and availability
- Use shielding caps for high voltage applications (STS family). Shielding caps may be purchased separately
- One wrench installation.

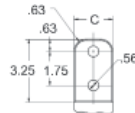
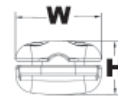
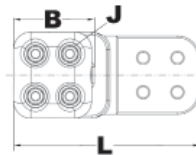

Fig. 1

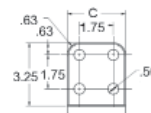

Fig. 2

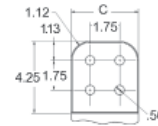

Fig. 3

Catalog Number	Fig. #	Al tube	Al stranded cable	ACSR Cable	B	C	J Dia.	L	H	W
SNAC22A4N	2	4 IPS	N/A	N/A	5.25	4.00	5/8	10.44	5.75	8.56
SNAC486A44N	3	N/A	2300 kcmil- 2500 kcmil	2156 (64/119) kcmil- 2167 (72/7) Kiwi kcmil	4.00	4.00	1/2	10.50	3.30	5.64
SNAC86A44NSTS	3	6 IPS	N/A	N/A	8.00	4.00	5/8	14.41	8.04	10.74

**TYPE SXA
TERMINAL**

For Use On EXPANSION TUBE
TO FLAT

Aluminum alloy expansion streamlined terminal for joining tube to pads.
Flexible aluminum straps allow for longitudinal or lateral movement and carries full load of the joint.

EHV RATED: SELF-SHIELDING UP TO 550 kV

Material: Aluminum Alloy
Hardware: Aluminum Hardware

Notes :

- PENETROX™ A joint compound is recommended on contact surfaces
- Please contact factory for other sizes, combinations and availability
- Use shielding caps for high voltage applications (STS family). Shielding caps may be purchased separately
- One side of pad finished on centerline of tubing. For finished pads on both sides add suffix "-Q" to catalog number.

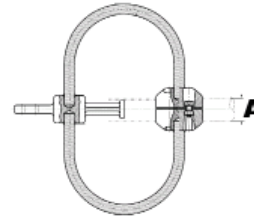
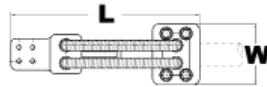
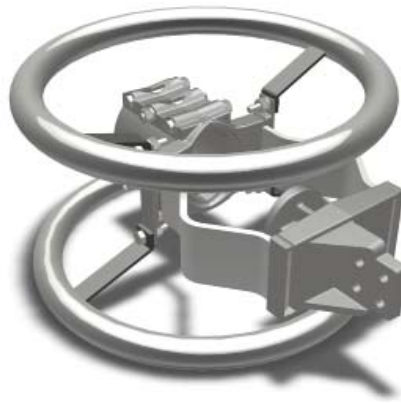

Catalog Number	Al Pipe Schd 40	L	W
SXA86A4NGS	6 IPS	34.00	18.50

**TYPE SF2A
TRANSFORMER
TERMINAL**

For Use On PAD
BIFURCATION

Weld type Application: Transformer
Terminal

**EHV RATED: SELF-SHIELDING UP
TO 550 kV**

Material: Aluminum Alloy

Hardware: Aluminum Hardware

Notes :

- PENETROX™ A joint compound is recommended on contact surfaces
- Please contact factory for other sizes, combinations and availability
- Use shielding caps for high voltage applications (STS family). Shielding caps may be purchased separately
- Please contact for various pad orientations and spacings

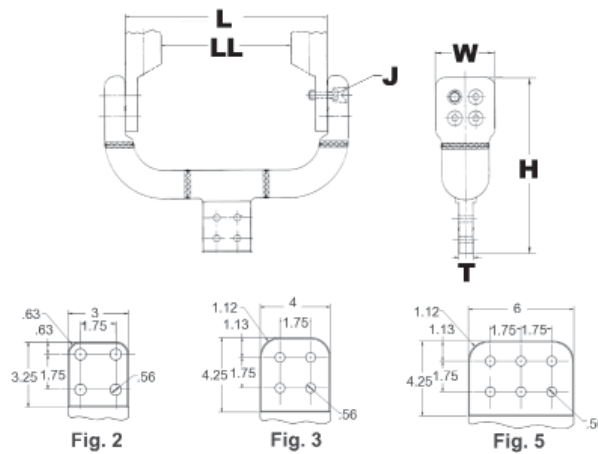

Catalog Number	Fig. #	L	H	W	T	LL	J Dia.
SF2A44NL12EX	3	17.21	14.75	5.00	.81	13.97	5/8

**TYPE SF3A
TERMINAL**

For Use On PAD
TRIFURCATION

(1) to (3) pads trifurcator.
**EHV RATED: SELF-SHIELDING UP
TO 550 kV**

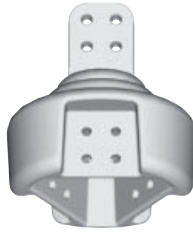

Material: Aluminum Alloy
Hardware: Aluminum Hardware

Notes :

- Use shielding caps for high voltage applications (STS family). Shielding caps may be purchased separately
- PENETROX™ A joint compound is recommended on contact surfaces
- Please contact factory for other sizes, combinations and availability

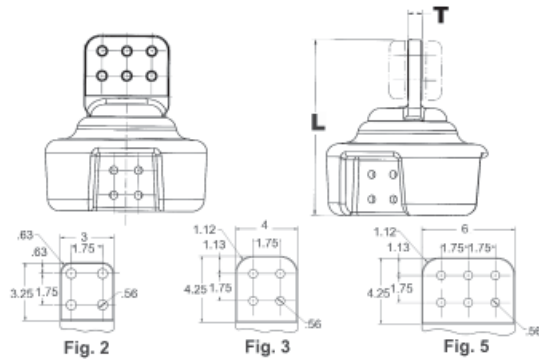

Catalog Number	Fig. #	L	T
SF3A44N8	3	12.42	.87
SF3A44N866N	5		1.00

**TYPE S2GBPA
SPACER TERMINAL**

For Use On (2) CABLES TO
TAP PAD

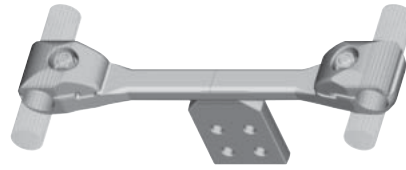

Streamlined rigid spacer for large range of cables with tap pad. Particularly appropriate for 8"+ spacing. 1 bolt per clamping module version. Pad requires STS shielding caps for EHV.

EHV RATED: SELF-SHIELDING UP TO 550kV

Material: Aluminum Alloy
Hardware: Aluminum Hardware

Notes :

- Properly proportioned to minimize conductor corrosion due to galvanic action. When properly used, this item does not require use of bimetallic plates. Please ask BURNDY® Technical Support for recommendations
- PENETROX™ A joint compound is recommended on contact surfaces
- Please contact factory for other sizes, combinations and availability
- One-wrench installation.

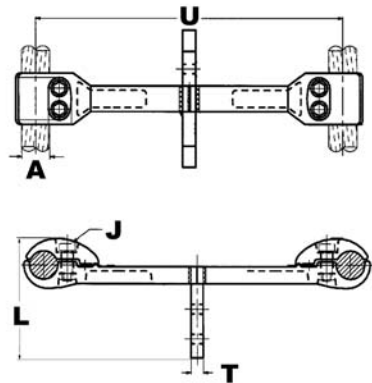

Catalog Number	Aluminum Stranded	Aluminum ACSR	T	J Dia.	U	L
S2GBPA36A8	350 kcmil-600 kcmil	336.4 (30/7) Oriole kcmil- 477. (30/7) Hen kcmil	.81	5/8	8	10.04
S2GBPA445A	1033 kcmil-1113 kcmil	954 (45/7) Rail kcmil- 1033.5 (54/7) Curlew kcmil		5/8	18	20.30
S2GBPA44A	954 kcmil	795 (54/7) Condor kcmil- 874.5 (54/7) Crane kcmil	.38	5/8	18	19.68
S2GBPA44A12	954 kcmil	795 (54/7) Condor kcmil	.81	5/8	12	12.00
S2GBPA44A8	954 kcmil	795 (54/7) Condor kcmil- 874.5 (54/7) Crane kcmil		5/8	8	9.74
S2GBPA45A	1192 kcmil-1272 kcmil	1033.5 (45/7) Ortolan kcmil- 1192.5 (45/7) Bunting kcmil	.50	5/8	18	20.26
S2GBPA45A12	1192 kcmil-1272 kcmil	1033.5 (45/7) Ortolan kcmil- 1192.5 (54/19) Grackle kcmil		5/8	12	14.32
S2GBPA46A12	1590 kcmil-1600 kcmil	1272 (54/19) Pheasant kcmil- 1431 (54/19) Plover kcmil	.38	5/8	12	12.00
S2GBPA46A8	1590 kcmil			5/8	8	10.30
S2GBPA486A12	2300 kcmil-2500 kcmil	2156 (84/19) Bluebird kcmil- 2167 (72/7) Kiwi kcmil	.81	5/8	12	14.56
S2GBPA48A	1750 kcmil-2000 kcmil	1590 (45/7) Lapwing kcmil- 1780 (84/19) Chukar kcmil		5/8	18	20.30
S2GBPA48A10	1750 kcmil-2000 kcmil			5/8	10	12.30
S2GBPA48A12	1750 kcmil-2000 kcmil			5/8	12	14.30
S2GBPA48A8	1750 kcmil-2000 kcmil			5/8	8	10.30

**TYPE S2GBPA-B2
SPACER**

For Use On (2) CABLES TO
TAP PAD



Streamlined rigid spacer for large range of cables with tap pad. Particularly appropriate for 8"+ spacing. 2 bolts per clamping module provides additional clamping strength. Pad requires STS shielding caps for EHV.

EHV RATED: SELF-SHIELDING UP TO 550kV

Material: Aluminum Alloy
Hardware: Aluminum Hardware

Notes :

- Properly proportioned to minimize conductor corrosion due to galvanic action. When properly used, this item does not require use of bimetallic plates. Please ask BURNDY® Technical Support for recommendations
- PENETROX™ A joint compound is recommended on contact surfaces
- Please contact factory for other sizes, combinations and availability
- One-wrench installation

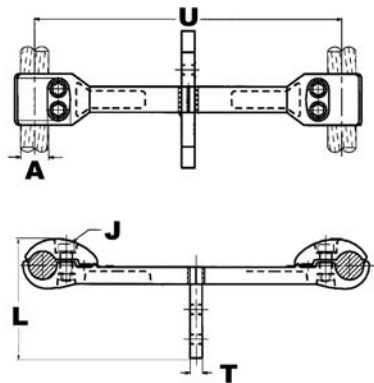

Catalog Number	Aluminum Stranded	Aluminum ACSR	J Dia.	U	L	T	C
S2GBPA44A12B2	954 kcmil	N/A	5/8	12	13.68	.81	4.00
S2GBPA45A12B2	1192 kcmil-1272 kcmil	1033.5 (54/7) Curlew kcmil- 1113 (54/19) Finch kcmil		12	13.84	.81	4.00
S2GBPA45AB2	1192 kcmil-1272 kcmil			18	20.32	.50	4.00
S2GBPA486A12B2	2300 kcmil-2500 kcmil	2156 (64/119) kcmil- 2312 (76/19) Thrasher kcmil		12	14.52	1.00	4.00
S2GBPA48A12B2	1750 kcmil-2000 kcmil	2156 (84/19) Bluebird kcmil- 2312 (76/19) Thrasher kcmil		12	14.30	.81	4.00

**TYPE S2GBPA-B4
SPACER**

For Use On (2) CABLES TO
TAP PAD

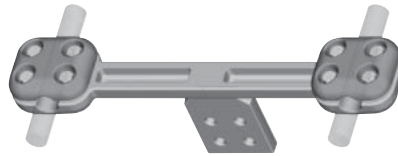

Streamlined rigid spacer for large range of cables with tap pad. Particularly appropriate for 8"+ spacing. Version with 4 bolts per clamping module - 2 on each side - provide ideal clamping of cable. Pad requires STS shielding caps for EHV. **EHV RATED: SELF-SHIELDING UP TO 550kV**

Material: Aluminum Alloy
Hardware: Aluminum Hardware

Notes :

- Properly proportioned to minimize conductor corrosion due to galvanic action. When properly used, this item does not require use of bimetallic plates. Please ask BURNDY® Technical Support for recommendations
- PENETROX™ A joint compound is recommended on contact surfaces
- Please contact factory for other sizes, combinations and availability
- One-wrench installation.

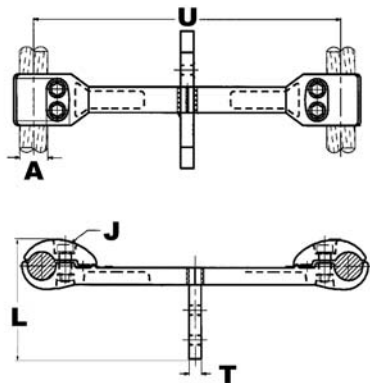

Catalog Number	Aluminum Stranded	Aluminum ACSR	T	J Dia.	U	L	C
S2GBPA41A12B4	795 kcmil-874 kcmil	795 (54/7) Condor kcmil	.44	5/8	12	13.42	4.00
S2GBPA445A12B4	1033 kcmil-1113 kcmil	954 (45/7) Rail kcmil- 1033.5 (54/7) Curlew kcmil		5/8	12	16.62	4.00
S2GBPA445AB4	1033 kcmil-1113 kcmil	954 (45/7) Rail kcmil- 1033.5 (45/7) Ortolan kcmil		5/8	18	22.60	4.00
S2GBPA44A12B4	954 kcmil	795 (26/7) Drake kcmil- 874.5 (54/7) Crane kcmil	.38	5/8	12	13.5	4.00
S2GBPA44AB4	954 kcmil	795 (30/19) Mallard kcmil- 874.5 (54/7) Crane kcmil		5/8	18	19.5	4.00
S2GBPA45A12B4	1192 kcmil-1272 kcmil	1033.5 (45/7) Ortolan kcmil- 1192.5 (54/19) Grackle kcmil	.44	5/8	12	14.32	4.00
S2GBPA46A12B4	1590 kcmil	1272 (54/19) Pheasant kcmil- 1431 (54/19) Plover kcmil	.62	5/8	12	13.82	4.00
S2GBPA483A12B4	2000 kcmil-2250 kcmil	2034.5 (72/7) Mockingbird kcmil- 2167 (72/7) Kiwi kcmil	.88	5/8	12	14.13	4.00
S2GBPA483AB4	2000 kcmil-2250 kcmil	1780 (84/19) Chukar kcmil- 2167 (72/7) Kiwi kcmil		5/8	18	20.13	4.00
S2GBPA486A12B4	2300 kcmil-2500 kcmil	2156 (64/119) kcmil- 2167 (72/7) Kiwi kcmil	1.00	5/8	12	14.32	4.00
S2GBPA486AB4	2300 kcmil-2500 kcmil			5/8	18	20.30	4.00
S2GBPA48A12B4	1750 kcmil-2000 kcmil	1590 (54/19) Falcon kcmil- 1780 (54/19) kcmil	.81	5/8	12	14.32	4.00

Table of Contents - Aluminum Bolted Couplers

	Type NL Pipe to Pipe (Angle)	A-39
	Type NNE Pipe to Cable In Line	A-40
	Type NNER Pipe to Cable In Line	A-41
	Type NNR Pipe to Pipe In Line	A-43
	Type NNRR Cable to Cable In Line	A-44
	Type NN2E(R) Pipe to 2 Cables In Line	A-45
	Type NS-A Pipe to Pipe	A-46
	Type NSHG Pipe to Base	A-47
	Type XP Expansion Pipe to Pipe	A48
	Type XPL Expansion Pipe to Pipe	A-49
	Type XHP-A Expansion Bus Coupler Pipe to Pipe	A-50
	Type SNS Pipe to Pipe In Line	A-51
	Type SNNS Pipe to Pipe In Line	A-52
	Type SNE Pipe to Cable In Line	A-53
	Type SNNE Pipe to Pipe In Line	A-54

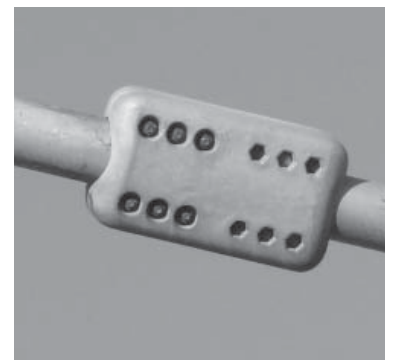
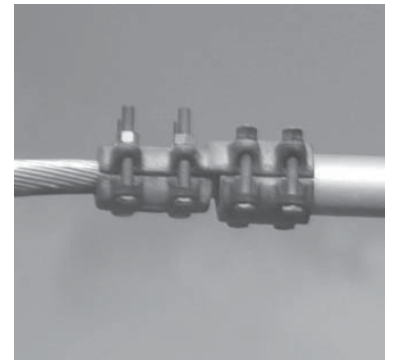
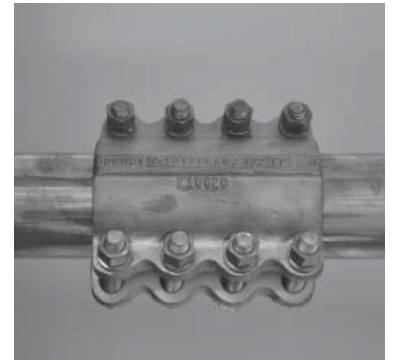

Table of Contents - Aluminum Bolted Couplers (continued)



Type SNN2E Pipe to 2 Cables In Line

A-55



Type SNNR Pipe to Pipe In Line

A-56



Type SXP Expansion Pipe to Pipe In Line

A-57



Type SXHP Expansion Bus Coupler Pipe to Pipe
In Line

A-58



Type SSXHP Sliding Expansion Bus Coupler Pipe
to Pipe In Line

A-59

**TYPE NL
ALUMINUM COUPLER**

For Use On TUBE TO TUBE
(ANGLE)

Aluminum alloy coupler for joining equal sizes of tube forming an elbow. Typical angles are 90°, 45° and 30°. Other angles may be available upon request. Properly proportioned to permit use on aluminum-copper conductor combinations. One-wrench installation.

Material: Aluminum Alloy
Hardware: Aluminum Hardware

Notes :

- PENETROX™ A joint compound is recommended on contact surfaces
- Please contact factory for other sizes, combinations and availability

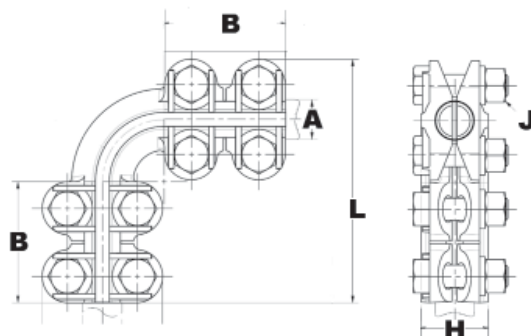

Catalog Number	A - Tube	Angle	B	J Dia.	L	H
NL15A15A	1 IPS	90°	3.50	1/2	6.50	2.62
NL16A16A	1 1/4 IPS	90°	2.75	1/2	6.00	2.38
NL16A16A45		45°	2.75	1/2	6.93	2.38
NL17A17A	1 1/2 IPS	90°	2.88	1/2	7.66	3.84
NL17A17A45		45°	4.00	1/2	7.31	3.84
NL18A18A	2 IPS	90°	4.25	5/8	9.00	4.38
NL18A18A45		45°	4.25	1/2	7.75	4.38
NL19A19A	2 1/2 IPS	90°	3.00	5/8	9.88	3.88
NL19A19A45		45°	3.00	5/8	10.50	3.88
NL20A20A	3 IPS	90°	5.00	5/8	10.72	5.38
NL20A20A45		45°	5.00	5/8	10.00	5.38
NL21A21A	3 1/2 IPS	90°	3.62	5/8	11.63	5.06
NL21A21A45		45°	3.62	5/8	12.25	5.06
NL22A22A	4 IPS	90°	6.00	5/8	12.62	6.19
NL22A22A45		45°	6.00	5/8	14.05	6.19
NL24A24A	5 IPS	90°	7.00	5/8	14.75	6.98
NL24A24A45		45°	7.00	5/8	17.00	6.98
NL86A86A	6 IPS	90°	8.00	5/8	18.38	8.00
NL86A86A45		45°	8.00	5/8	17.75	8.00

**TYPE NNE
BOLTED COUPLERS**

For Use On PIPE TO CABLE IN
LINE

Aluminum alloy coupler for tubing
run and cable tap, in-line. Captured
hex head bolts permit one-wrench
installation.



Material: Aluminum Alloy
Hardware: Aluminum Hardware

Notes :

- PENETROX™ A joint compound is recommended on contact surfaces
- Please call factory for other sizes, combinations and availability

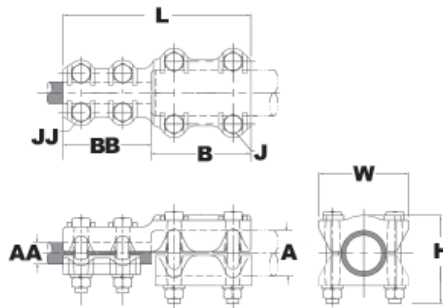

Catalog Number	A - Run Al tube	AA - Tap Al cable	AA - Tap ACSR cable	J Dia.	JJ Dia.	B	BB	W
NNE14A34A	3/4 IPS	450 kcmil- 500 kcmil	397.5 (18/1) Chickadee kcmil- 477.0 (30/7) Hen kcmil	1/2	1/2	3.25	3.50	2.80
NNE15A34A	1 IPS		397.5 (26/7) Ibis kcmil- 477.0 (26/7) Hawk kcmil	1/2	1/2	3.00	3.50	3.06
NNE18A36AGS	2 IPS	550 kcmil- 600 kcmil	477.0 (18/1) Pelican kcmil- 477.0 (30/7) Hen kcmil	5/8	1/2	4.25	3.25	4.50
NNE19A36A	2 1/2 IPS		477.0 (18/1) Pelican kcmil- 477.0 (30/7) Hen kcmil	5/8	1/2	3.94	3.25	4.69

**TYPE NNER
BOLTED COUPLERS**

For Use On PIPE TO CABLE IN LINE

Aluminum alloy coupler for tubing run and cable tap, in-line. Captured hex head bolts permit one-wrench installation.



Material: Aluminum Alloy
Hardware: Aluminum Hardware

Notes :

- PENETROX™ A joint compound is recommended on contact surfaces
- Please call factory for other sizes, combinations and availability

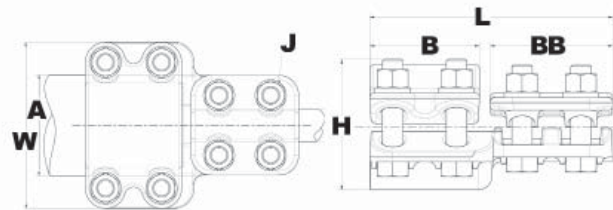

Catalog Number	A - Run Al tube	AA - Tap Al cable	AA - Tap ACSR cable	B	J Dia.	BB	L	H	W
NNER14A29A	3/4 IPS	1/0 AWG-250 kcmil	1/0 (6/1) Raven-4/0 (6/1) Penquin	3.25	1/2	2.88	6.25	3.13	2.88
NNER14A32A	3/4 IPS	250 kcmil-400 kcmil	4/0 (6/1) Penquin AWG-397.5 (18/1) Chickadee kcmil	3.50	1/2	3.12	6.50	3.13	2.88
NNER14A36A	3/4 IPS	350 kcmil-600 kcmil	336.4 (18/1) Merlin kcmil-477.0 (30/7) Hen kcmil	3.25	1/2	3.38	6.75	3.11	2.80
NNER15A25A	1 IPS	4 AWG-1/0 AWG	4 (6/1) Swan AWG-1/0 (6/1) Raven AWG	1.88	1/2	1.88	4.00	3.32	3.06
NNER15A29A	1 IPS	1/0 AWG-250 kcmil	1/0 (6/1) Raven-4/0 (6/1) Penquin	3.50	1/2	2.88	6.50	3.32	3.06
NNER15A32A	1 IPS	250 kcmil-400 kcmil	4/0 (6/1) Penquin AWG-397.5 (18/1) Chickadee kcmil	3.50	1/2	3.12	6.75	3.32	3.06
NNER15A36A	1 IPS	350 kcmil-600 kcmil	336.4 (18/1) Merlin kcmil-477.0 (18/1) Pelican kcmil	3.50	1/2	3.38	7.00	3.32	3.06
NNER15A42A	1 IPS	600 kcmil-900 kcmil	477.0 (18/1) Pelican kcmil-795 (54/7) Condor kcmil	3.50	1/2	3.62	7.25	3.32	3.06
NNER16A29A	1 1/4 IPS	1/0 AWG-250 kcmil	1/0 (6/1) Raven-4/0 (6/1) Penquin	3.75	1/2	3.88	6.75	3.38	3.50
NNER16A32A	1 1/4 IPS	250 kcmil-400 kcmil	4/0 (6/1) Penquin AWG-397.5 (18/1) Chickadee kcmil	3.75	1/2	3.12	7.01	3.41	3.41
NNER16A36A	1 1/4 IPS	350 kcmil-600 kcmil	336.4 (18/1) Merlin kcmil-477.0 (18/1) Pelican kcmil	3.75	1/2	3.38	7.63	3.38	3.50

TYPE NNER BOLTED COUPLERS

(Continued)



For Use On PIPE TO CABLE IN
LINE

Catalog Number	A - Run Al tube	AA - Tap Al cable	AA - Tap ACSR cable	B	J Dia.	BB	L	H	W
NNER16A42A	1 1/4 IPS	600 kcmil-900 kcmil	477.0 (18/1) Pelican kcmil-795 (54/7) Condor kcmil	3.75	1/2	3.62	7.50	3.40	3.41
NNER16A45A	1 1/4 IPS	900 kcmil-1250 kcmil	715.5 (54/7) Crow kcmil-1113 (54/19) Finch kcmil	3.94	1/2	3.88	7.75	3.61	3.40
NNER17A32A	1 1/2 IPS	250 kcmil-400 kcmil	4/0 (6/1) Penguin AWG-397.5 (18/1) Chickadee kcmil	4.00	1/2	3.00	7.25	3.82	3.64
NNER17A36A	1 1/2 IPS	350 kcmil-600 kcmil	336.4 (18/1) Merlin kcmil-477.0 (18/1) Pelican kcmil	4.00	1/2	3.38	7.50	3.82	3.64
NNER17A42A	1 1/2 IPS	600 kcmil-900 kcmil	477.0 (18/1) Pelican kcmil-795 (54/7) Condor kcmil	4.00	1/2	3.50	7.75	3.82	3.64
NNER17A45A	1 1/2 IPS	900 kcmil-1250 kcmil	715.5 (54/7) Crow kcmil-1113 (54/19) Finch kcmil	4.00	1/2	3.75	8.00	3.82	3.64
NNER17A46A	1 1/2 IPS	1250 kcmil-1600 kcmil	1113 (54/19) Finch kcmil-1431 (54/19) Plover kcmil	4.00	1/2	4.50	8.75	3.82	3.64
NNER17A48A	1 1/2 IPS	1500 kcmil-2000 kcmil	1272 (54/19) Pheasant kcmil-1780 (54/19) kcmil	4.00	1/2	4.62	8.75	3.82	3.64
NNER18A29A	2 IPS	1/0 AWG-250 kcmil	1/0 (6/1) Raven-4/0 (6/1) Penguin	4.00	1/2	2.88	7.00	4.32	4.13
NNER18A32A	2 IPS	250 kcmil-400 kcmil	4/0 (6/1) Penguin AWG-397.5 (18/1) Chickadee kcmil	4.00	1/2	3.12	7.25	4.33	4.12
NNER18A36A	2 IPS	350 kcmil-600 kcmil	336.4 (18/1) Merlin kcmil-477.0 (18/1) Pelican kcmil	4.00	1/2	3.38	7.50	4.38	4.12
NNER18A48A	2 IPS	1500 kcmil-2000 kcmil	1272 (54/19) Pheasant kcmil-1780 (54/19) kcmil	4.25	5/8	4.62	9.06	4.56	4.50
NNER19A32A	2 1/2 IPS	250 kcmil-400 kcmil	4/0 (6/1) Penguin AWG-397.5 (18/1) Chickadee kcmil	4.00	1/2	3.12	7.33	4.00	2.88
NNER18A42A	2 IPS	600 kcmil-900 kcmil	477.0 (18/1) Pelican kcmil-795 (54/7) Condor kcmil	4.00	1/2	3.50	7.75	4.32	4.12
NNER20A32A	3 IPS	250 kcmil-400 kcmil	4/0 (6/1) Penguin AWG-397.5 (18/1) Chickadee kcmil	4.06	1/2	3.12	7.75	5.00	5.25
NNER20A36A	3 IPS	350 kcmil-600 kcmil	336.4 (18/1) Merlin kcmil-477.0 (18/1) Pelican kcmil	4.00	1/2	3.62	7.63	5.00	5.25
NNER20A42A	3 IPS	600 kcmil-900 kcmil	477.0 (18/1) Pelican kcmil-795 (54/7) Condor kcmil	4.00	1/2	3.62	8.06	5.48	5.24
NNER20A45A	3 IPS	900 kcmil-1250 kcmil	715.5 (54/7) Crow kcmil-1113 (54/19) Finch kcmil	4.00	1/2	3.75	8.37	5.41	5.25
NNER20A46A	3 IPS	1400 kcmil-1600 kcmil	1272 (54/19) Pheasant kcmil-1780 (54/19) kcmil	5.00	5/8	4.50	9.81	5.41	5.62
NNER22A29A	4 IPS	1/0 AWG-250 kcmil	1/0 (6/1) Raven-4/0 (6/1) Penguin	6.00	1/2	2.88	7.25	5.75	6.25
NNER22A32A	4 IPS	250 kcmil-400 kcmil	4/0 (6/1) Penguin AWG-397.5 (18/1) Chickadee kcmil	6.00	1/2	3.12	7.50	5.75	6.25
NNER22A36A	4 IPS	350 kcmil-600 kcmil	336.4 (18/1) Merlin kcmil-477.0 (18/1) Pelican kcmil	6.00	1/2	3.38	10.06	6.19	6.63
NNER22A45A	4 IPS	900 kcmil-1250 kcmil	715.5 (54/7) Crow kcmil-1113 (54/19) Finch kcmil	6.00	1/2	3.88	8.25	5.75	6.25
NNER22A48A	4 IPS	1500 kcmil-2000 kcmil	1272 (54/19) Pheasant kcmil-1780 (54/19) kcmil	6.00	5/8	4.50	11.00	6.25	6.62

**TYPE NNR
BOLTED COUPLER**

For Use On PIPE TO SMALLER
PIPE

Aluminum alloy coupler for tubing run and tap, in-line. Captured hex head bolts permit one-wrench installation.

Material: Aluminum Alloy
Hardware: Aluminum Hardware

Notes :

- PENETROX™ A joint compound is recommended on contact surfaces
- Please call factory for other sizes, combinations and availability

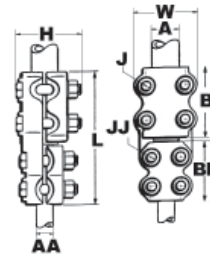

Catalog Number	A - Run tube	AA - Tap tube	B	J Dia.	JJ Dia.	BB	L	H	W
NNR15A14A	1 IPS	3/4 IPS	3.50	1/2	1/2	3.25	7.00	3.31	3.06
NNR16A15A	1 1/4 IPS	1 IPS	3.75	1/2	1/2	3.50	7.50	3.31	3.44
NNR17A14A	1 1/2 IPS	3/4 IPS	4.00	1/2	1/2	3.25	7.50	3.81	3.69
NNR17A15A	1 1/2 IPS	1 IPS	4.00	1/2	1/2	3.50	7.75	3.81	3.69
NNR17A16A	1 1/2 IPS	1 1/4 IPS	4.00	1/2	1/2	3.75	8.00	3.81	3.69
NNR18A14A	2 IPS	3/4 IPS	4.00	1/2	1/2	3.25	7.50	4.31	4.13
NNR18A15A	2 IPS	1 IPS	4.00	1/2	1/2	3.50	7.75	4.31	4.13
NNR18A16A	2 IPS	1 1/4 IPS	4.00	1/2	1/2	3.75	8.00	4.31	4.13
NNR18A17A	2 IPS	1 1/2 IPS	4.00	1/2	1/2	4.00	8.25	4.31	4.13
NNR19A14A	2 1/2 IPS	3/4 IPS	4.00	1/2	1/2	3.25	7.50	4.31	4.63
NNR19A15A	2 1/2 IPS	1 IPS	4.00	1/2	1/2	3.50	7.75	4.31	4.63
NNR19A16A	2 1/2 IPS	1 1/4 IPS	4.00	1/2	1/2	3.75	8.00	5.31	4.63
NNR19A17A	2 1/2 IPS	1 1/2 IPS	4.00	1/2	1/2	4.00	8.25	4.31	4.63
NNR19A18A	2 1/2 IPS	2 IPS	4.50	5/8	5/8	4.25	9.00	4.94	5.00
NNR20A17A	3 IPS	1 1/2 IPS	4.00	1/2	1/2	4.00	8.25	5.00	5.25
NNR20A18A	3 IPS	2 IPS	5.00	5/8	5/8	4.25	9.50	5.44	5.38
NNR20A19A	3 IPS	2 1/2 IPS	5.00	5/8	5/8	4.50	9.75	5.44	5.38
NNR21A18A	3 1/2 IPS	2 IPS	5.50	5/8	5/8	4.25	10.13	5.56	6.19
NNR21A20A	3 1/2 IPS	3 IPS	5.50	5/8	5/8	5.00	10.88	5.56	6.19
NNR22A18A	4 IPS	2 IPS	6.00	5/8	5/8	4.25	10.63	6.19	6.63
NNR24A20A	5 IPS	3 IPS	7.00	5/8	5/8	5.00	12.38	7.00	7.69

**TYPE NNRR
BOLTED COUPLER**

For Use On ALUMINUM CABLE
TO CABLE IN LINE

Aluminum alloy coupler for cable run and cable in-line tap. Captured hex head bolts for one-wrench installation.



Material: Aluminum Alloy
Hardware: Aluminum Hardware

Notes :

- PENETROX™ A joint compound is recommended on contact surfaces
- Please contact factory for other sizes, combinations and availability

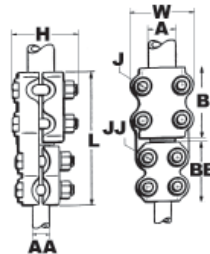

Catalog Number	A - Run Al cable	A - Run ACSR cable	AA - Tap Al cable	AA - Tap ACSR cable	B	J Dia.	JJ Dia.	BB	L	H	W
NNRR29A29A	1/0 AWG-250 kcmil	1/0 (6/1) Raven AWG-4/0 (6/1) Penquin AWG	1/0 AWG-250 kcmil	1/0 (6/1) Raven AWG-4/0 (6/1) Penquin AWG	2.75	1/2	1/2	2.75	5.75	2.56	2.50
NNRR32A29A	250 kcmil-400 kcmil	4/0 (6/1) Penquin AWG-397.5 (18/1) Chickadee kcmil	1/0 AWG-250 kcmil	1/0 (6/1) Raven AWG-4/0 (6/1) Penquin AWG	3.00	1/2	1/2	2.75	6.00	2.56	2.63
NNRR36A29A	350 kcmil-600 kcmil	336.4 (18/1) Merlin kcmil-477.0 (18/1) Pelican kcmil	1/0 AWG-250 kcmil	1/0 (6/1) Raven AWG-4/0 (6/1) Penquin AWG	3.25	1/2	1/2	2.75	6.25	2.56	2.75
NNRR36A36A	350 kcmil-600 kcmil		350 kcmil-600 kcmil	336.4 (18/1) Merlin kcmil-477.0 (18/1) Pelican kcmil	3.25	1/2	1/2	3.25	6.75	2.56	2.75
NNRR42A29A	600 kcmil-900 kcmil	477.0 (18/1) Pelican kcmil-795 (54/7) Condor kcmil	1/0 AWG-250 kcmil	1/0 (6/1) Raven AWG-4/0 (6/1) Penquin AWG	3.50	1/2	1/2	2.75	6.56	3.13	3.00
NNRR42A36A	600 kcmil-900 kcmil		350 kcmil-600 kcmil	336.4 (18/1) Merlin kcmil-477.0 (18/1) Pelican kcmil	3.50	1/2	1/2	3.25	7.06	3.13	3.00
NNRR42A42A	600 kcmil-900 kcmil		600 kcmil-900 kcmil	477.0 (18/1) Pelican kcmil-795 (54/7) Condor kcmil	3.50	1/2	1/2	3.50	5.31	3.13	3.00
NNRR48A42A	1500 kcmil-2000 kcmil	1272 (54/19) Pheasant kcmil-1780 (54/19) kcmil	600 kcmil-900 kcmil	477.0 (18/1) Pelican kcmil-795 (54/7) Condor kcmil	3.75	5/8	1/2	3.50	7.56	3.81	3.50
NNRR48A48A	1500 kcmil-2000 kcmil		1500 kcmil-2000 kcmil	1272 (54/19) Pheasant kcmil-1780 (54/19) kcmil	4.50	5/8	5/8	4.50	9.56	3.81	3.88

**TYPE NN2E(R)
BOLTED COUPLER**

For Use On ALUMINUM PIPE
TO (2) CABLE IN LINE

Aluminum alloy coupler for tubing run and cable tap, in-line. Captured hex head bolts permit one-wrench installation.

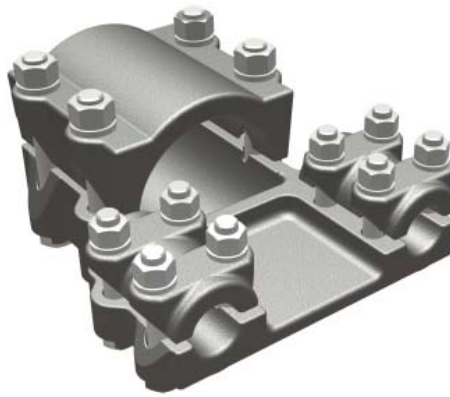

Material: Aluminum Alloy
Hardware: Aluminum Hardware

Notes :

- PENETROX™ A joint compound is recommended on contact surfaces
- Please contact factory for other sizes, combinations and availability

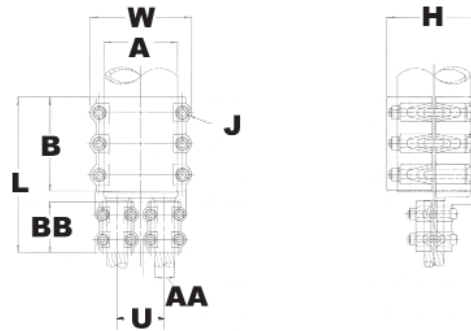

Catalog Number	A - Run Al tube	AA - Tap Al cable	AA - Tap ACSR cable	B	J Dia.	BB	U	L	H	W
NN2ER20A45A	3 IPS	900 kcmil- 1250 kcmil	715.5 (54/7) Crow kcmil- 1113 (54/19) Finch kcmil	5.00	1/2	3.81	3.45	9.75	5.40	5.62

**TYPE NS-A
COUPLER**

For Use On ALUMINUM TUBE
TO TUBE

Aluminum alloy coupler for joining equal sizes of tube end to end. Properly proportioned to permit use on aluminum-copper conductor combinations. One-wrench installation. PENETROX™ joint compound recommended on contact surfaces.

Material: Aluminum Alloy
Hardware: Aluminum Hardware

Notes :

- PENETROX™ A joint compound is recommended on contact surfaces
- Please contact factory for other sizes, combinations and availability

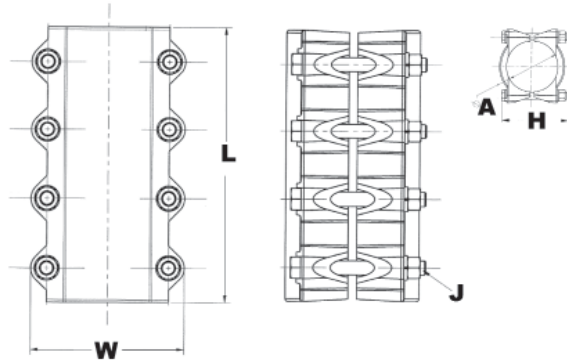

Catalog Number	A - tube	J Dia.	L	H	W
NS14A14A	3/4 IPS	1/2	6.75	2.06	2.80
NS15A15A	1 IPS		7.25	2.18	3.06
NS16A16A	1 1/4 IPS		7.75	3.50	3.41
NS17A17A	1 1/2 IPS		8.25	4.00	3.64
NS18A18A	2 IPS	5/8	8.75	4.62	4.50
NS19A19A	2 1/2 IPS		9.31	4.26	5.00
NS20A20A	3 IPS		10.25	5.62	5.63
NS21A21A	3 1/2 IPS		8.00	5.25	6.14
NS22A22A	4 IPS		12.00	5.94	6.62
NS23A23A	4 1/2 IPS		13.25	6.38	7.14
NS24A24A	5 IPS		14.38	6.94	7.70
NS86A86A	6 IPS	16.25	8.04	8.76	

**TYPE NSHG
BUS SUPPORT**

For Use On PIPE TO BASE

Aluminum alloy bus support for coupling same diameter tubes on post or pedestal insulators.

Material: Aluminum Alloy
Hardware: Aluminum Hardware

Notes :

- PENETROX™ A joint compound is recommended on contact surfaces
- Please contact factory for other sizes, combinations and availability

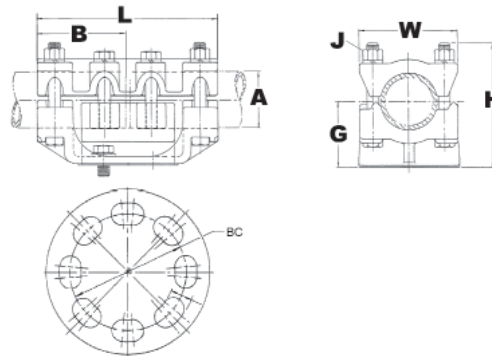

Catalog Number	A-tube	BC	G	J Dia.	B	L	H	W
NSHG16A3	1 1/4 IPS	3.00	2.25	1/2	4.00	7.56	4.06	3.50
NSHG17A3	1 1/2 IPS		2.50	1/2	4.00	7.66	4.62	3.78
NSHG18A3	2 IPS		2.75	1/2	4.00	8.125	5.25	4.25
NSHG18A5	2 IPS	5.00	2.87	1/2	4.00	10.12	4.62	4.08
NSHG19A3	2 1/2 IPS	3.00	3.12	1/2	4.00	8.125	5.50	4.62
NSHG20A5	3 IPS	5.00	3.62	5/8	5.00	10.60	6.69	5.62
NSHG21A5	3 1/2 IPS		4.00	5/8	5.00	10.56	6.94	6.13
NSHG22A5	4 IPS		4.50	5/8	5.00	11.34	7.81	6.62

**TYPE XP
EXPANSION COUPLER**

For Use On FOR COPPER
TUBE TO TUBE

Aluminum expansion coupler for joining equal size tube on end. One-wrench installation.

Material: Aluminum Alloy
Hardware: Aluminum Hardware

Notes :

- PENETROX™ A joint compound is recommended on contact surfaces
- Please contact factory for other sizes, combinations and availability
- Conductor smaller than 3 inch bus size is not recommended for 550kV

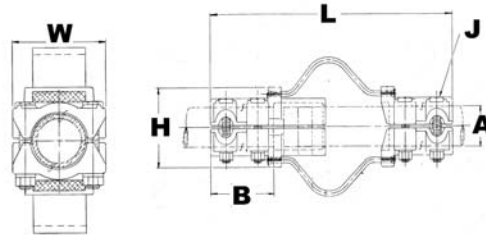

Catalog Number	Pipe Size Schd 40	Pipe Size Schd 80	B	L	J Dia.	H	W
XP17A17A	1 1/2 IPS	N/A	4.00	15.17	1/2	4.50	3.64
XP18A18A	2 IPS		4.25	16.14	5/8	5.26	4.50
XP19A19A	2 1/2 IPS		4.50	17.78	5/8	5.72	5.00
XP20A20A	3 IPS		5.00	19.56	5/8	6.80	5.62
XP22A22A	4 IPS		6.00	22.62	5/8	8.16	6.62
XP24A24A	5 IPS		7.00	26.66	5/8	9.74	7.69
XP59A59A	N/A	2 1/2 IPS	4.50	17.78	5/8	5.90	5.00
XP90A90A	N/A	3 IPS	5.00	19.56	5/8	7.06	5.62

**TYPE XPL
EXPANSION COUPLER**

For Use On TUBE TO TUBE

Aluminum alloy expansion coupler accommodating tube to tube. Flexible aluminum straps allow for longitudinal or lateral movement and carries full current load of the joint. PENETROX™ joint compound recommended on contact surfaces. Pad contact surface is on centerline of conductor.

Material: Aluminum Alloy
Hardware: Aluminum Hardware

Notes :

- PENETROX™ A joint compound is recommended on contact surfaces
- Conductor smaller than 3 inch bus size is not recommended for 550kV

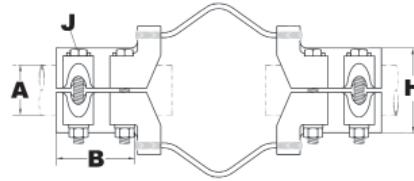
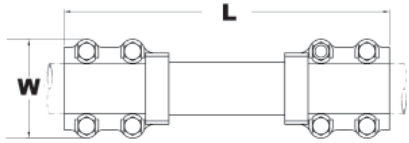

Catalog Number	Pipe Size Schd 40	Pipe Size Schd 80	B	L	J Dia.	H	W
XPL16A16A	1 1/4 IPS	N/A	3.75	13.57	1/2	4.00	3.41
XPL17A17A	1 1/2 IPS		4.00	13.92	1/2	4.50	3.64
XPL20A20A	3 IPS		5.00	19.00	5/8	6.80	5.62
XPL56A56A	N/A	1 1/4 IPS	3.75	13.57	1/2	4.06	3.41
XPL57A57A	N/A	1 1/2 IPS	4.00	13.92	1/2	4.64	3.64
XPL59A59A	N/A	2 1/2 IPS	4.50	17.78	5/8	5.90	5.00

**TYPE XHP-A
EXPANSION COUPLER**

For Use On EXPANSION PIPE COUPLER TO BASE

Expansion coupler aluminum alloy bus support for coupling tube on post or pedestal type insulators.

Material: Aluminum Alloy
Hardware: Aluminum Hardware

Notes :

- Conductor smaller than 3 inch bus size is not recommended for 550kV
- Specify base mounting hardware, if required, by adding suffix -B to catalog number
- PENETROX™ A joint compound is recommended on contact surfaces
- Bus support couplers are supplied without bus end plugs. If end plugs are required add suffix “-EP” to catalog number

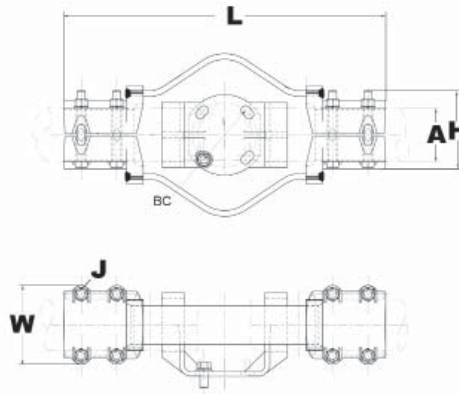
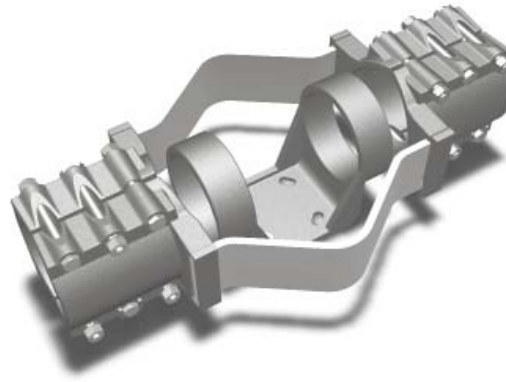

Catalog Number	Pipe Size Schd 40	Pipe Size Schd 80	BC	L	J Dia.	H	W
XHP16A3	1 1/4 IPS	N/A	3.00	18.13	1/2	3.95	3.40
XHP16A5	1 1/4 IPS		5.00		1/2	4.08	3.40
XHP17A3	1 1/2 IPS		3.00	19.13	1/2	4.32	3.64
XHP17A5	1 1/2 IPS		5.00		1/2	4.32	3.64
XHP18A3	2 IPS		3.00	20.75	5/8	5.00	4.50
XHP19A3	2 1/2 IPS		3.00	21.88	5/8	5.62	5.00
XHP19A5	2 1/2 IPS		5.00	26.00	5/8	12.77	5.00
XHP20A3	3 IPS		3.00	23.63	5/8	6.43	5.63
XHP20A5	3 IPS		5.00	26.00	5/8	6.43	5.63
XHP21A5	3 1/2 IPS		5.00	25.00	5/8	7.61	6.13
XHP22A3	4 IPS		3.00	24.18	5/8	7.81	6.63
XHP22A5	4 IPS		5.00	26.25	5/8	7.81	6.63
XHP24A3	5 IPS		3.00	38.00	5/8	9.10	7.69
XHP24A5	5 IPS		5.00	29.56	5/8	9.10	7.69
XHP86A5	N/A	6 IPS	5.00	32.00	5/8	9.94	8.75
XHP90A5	N/A	3 IPS	5.00	24.18	5/8	6.43	5.63
XHP92A3	N/A	4 IPS	3.00	26.25	5/8	7.81	6.63
XHP92A5	N/A		5.00		5/8	7.81	6.63

**TYPE SNS
COUPLERS**

For Use On TUBE TO TUBE

Aluminum alloy coupler for joining equal sizes of tube end to end. Properly proportioned to permit use on aluminum conductor combinations. PENETROX™ joint compound recommended on contact surfaces.
EHV RATED: SELF-SHIELDING UP TO 550 kV



Material: Aluminum Alloy
Hardware: Aluminum Hardware

Notes :

- Scratch brush connector contact, surface dry then apply an oxide inhibitor. We recommend the BURNDY® joint compound PENETROX™ A, which can be purchased in cans, tubs and plastic squeeze bottles
- PENETROX™ A joint compound is recommended on contact surfaces
- Please contact factory for other sizes, combinations and availability.

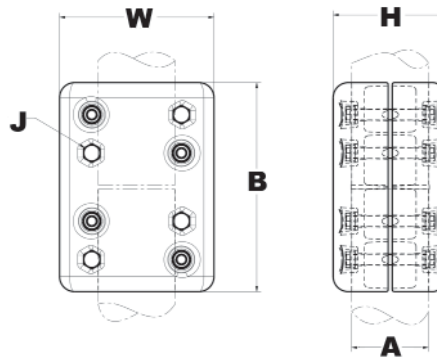

Catalog Number	A - Tube	B	J Dia.	H	W
SNS19ACG1	2 1/2 IPS	4.62	1/2	4.50	4.75
SNS20ACG2	3 IPS		1/2	5.00	5.38
SNS21ACG1	3 1/2 IPS	11.31	5/8	6.00	6.25
SNS22ACG2	4 IPS	6.00	5/8	6.12	8.75
SNS23ACG1	4 1/2 IPS	18.38	5/8	6.86	10.44
SNS83A83A	8 OD	21.00	5/8	10.06	13.12
SNS86ACG1	6 IPS	18.00	5/8	8.18	8.44

**TYPE SNNS
COUPLER**

For Use On TUBE TO TUBE

Aluminum alloy coupler for joining equal sizes of tube end to end. Properly proportioned to permit use on aluminum conductor combinations.
EHV RATED: SELF-SHIELDING UP TO 550 kV



Material: Aluminum Alloy
Hardware: Aluminum Hardware

Notes :

- PENETROX™ A joint compound is recommended on contact surfaces
- Scratch brush connector contact, surface dry then apply an oxide inhibitor. We recommend the BURNDY® joint compound PENETROX™ A, which can be purchased in cans, tubs and plastic squeeze bottles
- Please contact factory for other sizes, combinations and availability

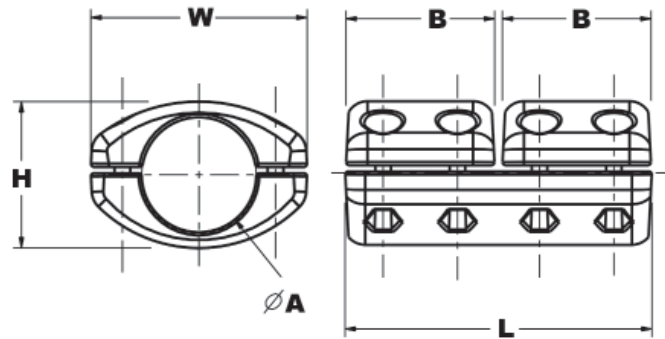

Catalog Number	A - Tube	B	J Dia.	L	H	W
SNNS24A24A	5 IPS	7.00	5/8	14.38	6.94	9.68
SNNS86A86A	6 IPS	8.00	5/8	16.38	8.04	10.74

**TYPE SNE
STREAMLINED END
CONNECTOR**

For Use On TUBE TO CABLE

Aluminum alloy streamlined end connector.

EHV RATED: SELF-SHIELDING UP TO 550 kV

Material: Aluminum Alloy

Hardware: Aluminum Hardware

Notes :

- PENETROX™ A joint compound is recommended on contact surfaces
- Scratch brush connector contact, surface dry then apply an oxide inhibitor. We recommend the BURNDY® joint compound PENETROX™ A, which can be purchased in cans, tubs and plastic squeeze bottles
- Please contact factory for other sizes, combinations and availability

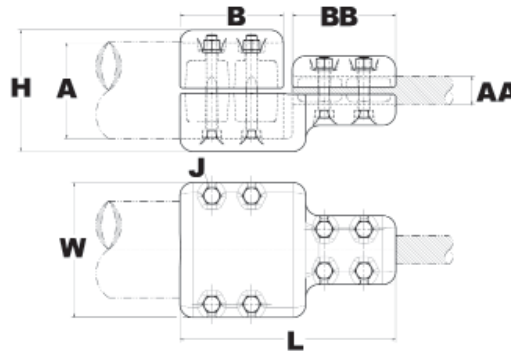

Catalog Number	A - Run Al tube	AA - Tap Al cable	J Dia.	B	BB	L	H	W
SNE22ACG2	4 IPS	1272 kcmil	1/2	4.88	4.88	10.19	5.74	6.38

**TYPE SNNE
STREAMLINED END
CONNECTOR**

For Use On TUBE TO CABLE

Aluminum alloy streamlined end connector.

EHV RATED: SELF-SHIELDING UP TO 550 kV



Material: Aluminum Alloy
Hardware: Aluminum Hardware

Notes :

- PENETROX™ A joint compound is recommended on contact surfaces
- Scratch brush connector contact, surface dry then apply an oxide inhibitor. We recommend the BURNDY® joint compound PENETROX™ A, which can be purchased in cans, tubs and plastic squeeze bottles
- Please contact factory for other sizes, combinations and availability

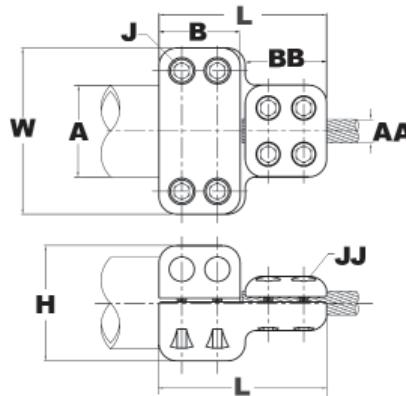

Catalog Number	A - Run Al tube	AA - Tap Al cable	B	J Dia.	JJ Dia.	BB	L	H	W
SNNE19A48AG1	2 1/2 IPS	2000 kcmil	7.00	5/8	1/2	4.50	12.00	3.62	5.00

**TYPE SNN2E
STREAMLINED END
CONNECTOR**

For Use On TUBE TO CABLE

Aluminum alloy streamlined end connector.

EHV RATED: SELF-SHIELDING UP TO 550 kV

Material: Aluminum Alloy

Hardware: Aluminum Hardware

Notes :

- PENETROX™ A joint compound is recommended on contact surfaces
- Scratch brush connector contact, surface dry then apply an oxide inhibitor. We recommend the BURNDY® joint compound PENETROX™ A, which can be purchased in cans, tubs and plastic squeeze bottles
- Please contact factory for other sizes, combinations and availability

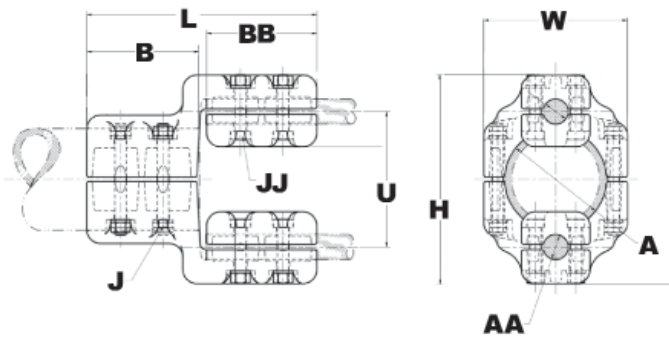

Catalog Number	A - Run Al tube	AA - Tap Al cable	AA - Tap ACSR cable	B	J Dia.	JJ Dia.	BB	L	H	W	U
SNN2E22A44AS3L6GS	4 IPS	N/A	795 (26/7) Drake kcmil- 795 (30/19) Mallard kcmil	4.88	1/2	1/2	4.88	10.19	9.24	6.36	6.00
SNN2E22A495AS2L13GS	4 IPS	3500 kcmil	N/A	6.50	5/8	1/2	6.00	13.26	6.12	16.90	13.00

**TYPE SNNR
REDUCER**

For Use On TUBE TO TUBE

Aluminum alloy reducer for joining a wide range of tubes of various sizes.
EHV RATED: SELF-SHIELDING UP TO 550 kV

Material: Aluminum Alloy
Hardware: Aluminum Hardware

Notes :

- PENETROX™ A joint compound is recommended on contact surfaces
- Scratch brush connector contact, surface dry then apply an oxide inhibitor. We recommend the BURNDY® joint compound PENETROX™ A, which can be purchased in cans, tubs and plastic squeeze bottles
- Please contact factory for other sizes, combinations and availability

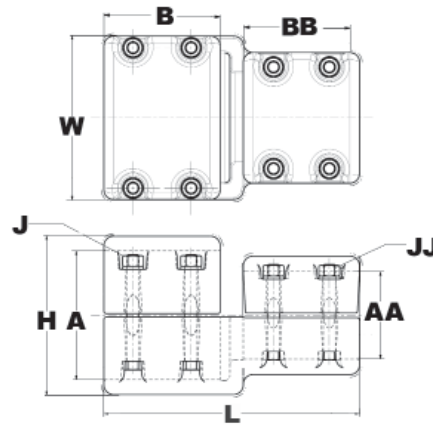

Catalog Number	A - Run tube	AA - Tap tube	B	J Dia.	BB	L	H	JJ Dia.	W
SNNR86A22A	6 IPS	4 IPS	6.00	5/8	6.00	13.19	8.18	5/8	8.44

**TYPE SXP
STREAMLINED
ALUMINUM COUPLER**

For Use On TUBE TO TUBE

Aluminum alloy expansion coupler for Bus to Bus connection.

EHV RATED: SELF-SHIELDING UP TO 550kV

Material: Aluminum Alloy

Hardware: Aluminum Hardware

Notes :

- Conductor smaller than 3 inch bus size is not recommended for 550kV
- Specify base mounting hardware, if required, by adding suffix -B to catalog number
- PENETROX™ A joint compound is recommended on contact surfaces

Please contact factory for other sizes, combinations and availability

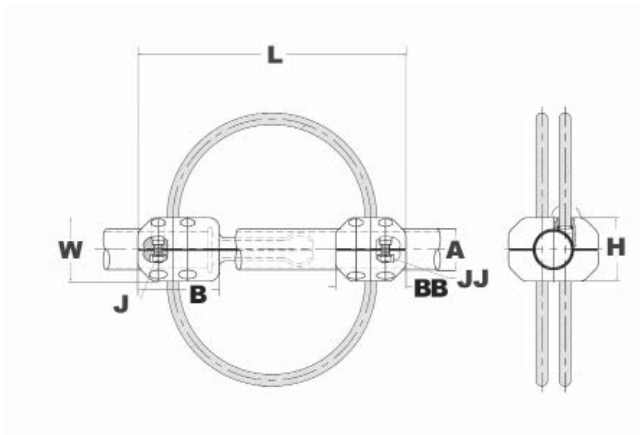

Catalog Number	Pipe Size Schd 40	B	BB	L	J Dia.	JJ Dia.	H	W
SXP22ACG1	4 IPS	5.12	3.78	25.52	5/8	5/8	10.8	4.19
SXP86ACG2	6 IPS	7.34	3.50	29.46	5/8	5/8	11.02	8.97

**TYPE SXHP
STREAMLINED
EXPANSION COUPLER**

For Use On EXPANSION PIPE
COUPLER TO BASE

Streamlined expansion aluminum alloy
bus support for coupling tube on post
or pedestal type insulators.

**EHV RATED: SELF-SHIELDING UP
TO 550kV**

Material: Aluminum Alloy
Hardware: Aluminum Hardware

Notes :

- Conductor smaller than 3 inch bus size is not recommended for 550kV
- Specify base mounting hardware, if required, by adding suffix -B to catalog number
- PENETROX™ A joint compound is recommended on contact surfaces
- Bus support couplers are supplied without bus end plugs. If end plugs are required add suffix “-EP” to catalog number.

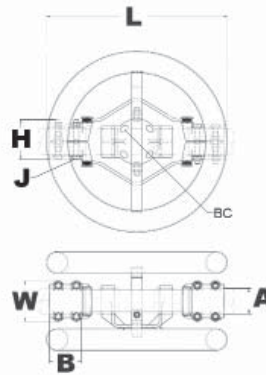

Catalog Number	Pipe Size Schd 80	BC	B	L	J Dia.	H	W
SXHP94A5	5 IPS	5.00	7.00	29.56	5/8	10.74	7.96

**TYPE SSXHP
BUS SUPPORT**

For Use On EXPANSION TUBE
COUPLER TO BASE

Streamlined guided expansion aluminum alloy bus support for coupling tube on post or pedestal type insulators. Alone, rated up to 230kV. Can be combined with SR family corona rings to reach 345kV (one ring) or 765kV (2 rings). Corona rings sold separately.

Material: Aluminum Alloy
Hardware: Aluminum Hardware

Notes :

- PENETROX™ A joint compound is recommended on contact surfaces
- Please contact factory for other sizes, combinations and availability
- Bus support couplers are supplied without bus end plugs. If end plugs are required add suffix "-EP" to catalog number.

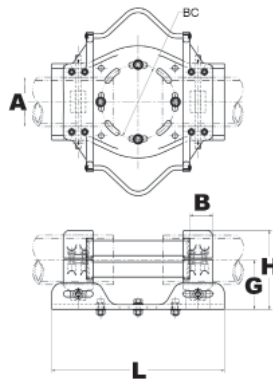

Catalog Number	A - Tube	B	BC	L	H	G
SSXHP22A10HQ	4 IPS	6.42	10.00	25.00	8.37	5.50
SSXHP83A5	8 OD		5.00	25.00	12.79	7.36
SSXHP83A7	8 OD		7.00	25.00	12.79	7.36
SSXHP86A10HQ	6 IPS		10.00	25.00	10.60	6.60

Table of Contents - Aluminum Bolted Bus Supports

	Type UHKR-A Cable or Pipe	A-63
	Type U2HKR-A Cable or Pipe	A-64
	Type UHG Pipe	A-65
	Type OH-A Pipe	A-67
	Type NVHA Vertical Pipe	A-68
	Type NSHG Pipe	A-69
	Type SUHK Cable	A-70
	Type SUHG Pipe	A-71
	Type SSXHP Sliding Expansion Pipe Coupler	A-72
	Type XHP-A Expansion Pipe	A-73
	Type SXHP Expansion Pipe	A-74
	Type SH2GBP-B2 Rigid Cable Spacer with Insulator Mount	A-75
	Type SH2GBP-B4 Rigid Cable Spacer with Insulator Mount	A-76
	Type SH2GBP Rigid Cable Spacer with Insulator Mount	A-77



**TYPE UHKR-A
BUS SUPPORT**

For Use On CABLE OR TUBE
TO BASE

Aluminum alloy bus support for mounting a wide range of cable or tube on post or pedestal type insulators. Supplied with hardware for mounting to cap of insulator.

Material: Aluminum Alloy
Hardware: Aluminum Hardware

Notes :

- PENETROX™ A joint compound is recommended on contact surfaces
- Specify base mounting hardware, if required, by adding suffix -B to catalog number
- Please contact factory for other sizes, combinations and availability

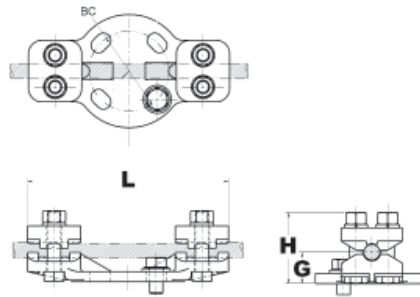

Catalog Number	Tube Size	Al Cable	ACSR Cable	BC	G	L	H
UHKR11A3	1/4 IPS	4 AWG- 4/0 AWG	6 (6/1) Turkey AWG- 4/0 (6/1) Penquin AWG	3.00	1.16	7.56	2.63
UHKR11A5	1/4 IPS			5.00	1.16	8.50	2.63
UHKR13A3	3/8 IPS - 1/2 IPS	250 kcmil- 550 kcmil	266.8 (26/7) Owl kcmil- 477 (30/7) Hen kcmil	3.00	1.32	7.56	3.88
UHKR13A5	3/8 IPS - 1/2 IPS			5.00	1.32	8.88	2.88
UHKR14A3	3/4 IPS	600 kcmil- 1113 kcmil	556.5 (26/7) Dove kcmil- 1033.5 (54/7) Curlew kcmil	3.00	1.72	7.56	3.56
UHKR14A5	3/4 IPS			5.00	1.53	9.06	3.38
UHKR16A3	1 IPS - 1 1/4 IPS	1000 kcmil- 2000 kcmil	1113 (54/19) Finch kcmil- 1780 (84/19) Chukar kcmil	3.00	1.97	7.56	4.06
UHKR16A5	1 IPS - 1 1/4 IPS			5.00	1.80	9.25	3.88
UHKR17A3	1 1/4 IPS - 1 1/2 IPS	2000 kcmil- 2500 kcmil	1780 (84/19) Chukar kcmil- 2156 (84/19) Bluebird kcmil	3.00	2.50	8.02	4.62
UHKR17A5	1 1/4 IPS - 1 1/2 IPS			5.00	2.50	9.31	4.62

**TYPE U2HKR-A
BUS SUPPORT**

For Use On (2) PIPE OR
CABLE TO BASE



Aluminum alloy bus support for mounting tube on post or pedestal insulators. Properly proportioned to minimize conductor corrosion due to galvanic action. Rotate caps 180° for slip or rigid fit. One-wrench installation. Supplied with hardware for mounting to cap of insulator.

Material: Aluminum Alloy
Hardware: Aluminum Hardware

Notes :

- PENETROX™ A joint compound is recommended on contact surfaces
- Specify base mounting hardware, if required, by adding suffix -B to catalog number
- For static clips add suffix "-CH" to catalog number.

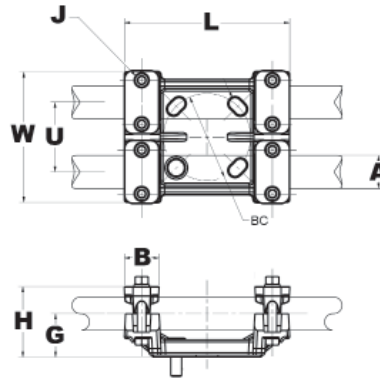

Catalog Number	Pipe Size	Al Cable	ACSR Cable	BC	G	J Dia.	U	L	H	W
U2HKR13A3	3/8 IPS - 1/2 IPS	250 kcmil- 550 kcmil	266.8 (26/7) Owl kcmil- 477 (30/7) Hen kcmil	3.00	1.32	1/2	2.89	7.56	2.88	5.53
U2HKR13A5	3/8 IPS - 1/2 IPS			5.00	1.32	1/2	2.89	6.35	2.88	5.60
U2HKR14A3	3/4 IPS	600 kcmil- 1113 kcmil	556.5 (24/7) Parakeet kcmil- 1033.5 (54/7) Curlew kcmil	3.00	1.72	1/2	3.25	7.56	3.56	6.25
U2HKR14A5	3/4 IPS			5.00	2.03	1/2	2.00	6.35	3.43	5.60
U2HKR16A3	1 IPS - 1 1/4 IPS	1000 kcmil- 2000 kcmil	1113 (54/19) Finch kcmil- 1780 (84/19) Chukar kcmil	3.00	1.97	1/2	3.66	7.56	4.06	7.06
U2HKR16A5	1 IPS - 1 1/4 IPS			5.00	1.97	1/2	3.66	9.60	4.06	7.88
U2HKR17A5	1 1/4 IPS - 1 1/2 IPS	2000 kcmil- 2500 kcmil	1780 (84/19) Chukar kcmil- 2156 (84/19) Bluebird kcmil	5.00	2.50	1/2	4.00	9.50	4.63	7.56
U2HR17A3	1 1/4 IPS - 1 1/2 IPS			3.00	2.50	1/2	2.82	6.75	4.42	4.32

**TYPE UHG
BUS SUPPORT**

For Use On FIXED OR RIGID
PIPE TO BASE

Aluminum alloy bus support for mounting tube on post or pedestal insulators. Properly proportioned to minimize conductor corrosion due to galvanic action. Caps are reversible for FIX or RIGID fit. One-wrench installation. Supplied with hardware for mounting to cap of insulator.

Material: Aluminum Alloy
Hardware: Aluminum Hardware

Notes :

- PENETROX™ A joint compound is recommended on contact surfaces
- Specify base mounting hardware, if required, by adding suffix -B to catalog number
- For static clips add "-CH" to Catalog Number.

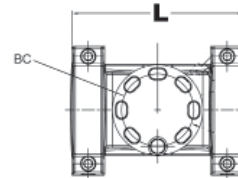
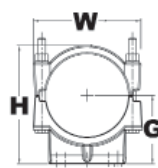
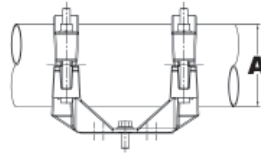

Catalog Number	A	BC	G	L	H	W
UHG13A3CH	1/2 IPS	3.00	1.75	7.44	3.09	2.66
UHG14A-3	3/4 IPS			7.44	3.50	2.94
UHG14A3CH	3/4 IPS		2.00	7.44	3.50	2.94
UHG15A-3	1 IPS		7.44	3.88	3.06	
UHG15A3CH	1 IPS		7.44	3.88	3.19	
UHG15A-5	1 IPS	5.00	2.25	9.82	3.82	3.19
UHG15A5CH	1 IPS			9.82	3.82	3.19
UHG16A3CH	1 1/4 IPS	3.00	2.38	7.68	3.79	3.50
UHG16A5CH	1 1/4 IPS	5.00		10.06	3.94	3.50
UHG17A-3	1 1/2 IPS	3.00	2.50	7.68	4.06	3.66
UHG17A3CH	1 1/2 IPS			7.68	4.06	3.66
UHG17A-5	1 1/2 IPS	5.00		10.06	4.06	3.66
UHG17A5CH	1 1/2 IPS			10.06	4.06	3.66
UHG18A-3	2 IPS	3.00		2.75	7.68	5.25
UHG18A3CH	2 IPS		7.68		5.25	4.12
UHG18A-5	2 IPS	5.00	10.06		4.61	4.12
UHG18A5CH	2 IPS		10.06		4.61	4.12
UHG19A-3	2 1/2 IPS	3.00	3.12		7.68	5.23
UHG19A3CH	2 1/2 IPS			7.68	5.23	4.62
UHG19A5CH	2 1/2 IPS			5.00	10.56	5.23

TYPE UHG BUS SUPPORT

(Continued)

For Use On FIXED OR RIGID
PIPE TO BASE



Catalog Number	A	BC	G	L	H	W
UHG20A3CH	3 IPS	3.00	3.62	9.25	6.09	5.62
UHG20A-5	3 IPS	5.00		10.56	6.09	5.62
UHG20A5CH	3 IPS			10.56	6.09	5.62
UHG20A7CH	3 IPS	7.00		12.80	8.46	8.46
UHG21A-3	3 1/2 IPS	3.00	4.00	8.18	6.74	6.16
UHG21A3CH	3 1/2 IPS			8.18	6.74	6.16
UHG21A5CH	3 1/2 IPS			5.00	10.56	6.74
UHG22A3CH	4 IPS	3.00	4.50	8.18	7.50	6.62
UHG22A-5	4 IPS	5.00		11.34	7.50	6.62
UHG22A5CH	4 IPS			11.34	7.50	6.62
UHG24A-3	5 IPS	3.00	5.25	8.68	8.86	7.70
UHG24A3CH	5 IPS			8.68	8.86	7.70
UHG24A-5	5 IPS	5.00		11.56	8.86	7.70
UHG24A5CH	5 IPS			11.56	8.86	7.70
UHG83A5	8 IPS	5.00	7.16	11.56	11.84	10.12
UHG86A5CH	6 IPS		5.56	11.56	9.94	8.75

**TYPE OH-A
BUS SUPPORT**

For Use On PIPE TO BASE (O SHAPE)

Aluminum alloy bus support for mounting tube on post or pedestal insulators.

Material: Aluminum Alloy
Hardware: Aluminum Hardware

Notes :

- PENETROX™ A joint compound is recommended on contact surfaces
Please contact factory for other sizes and availability.

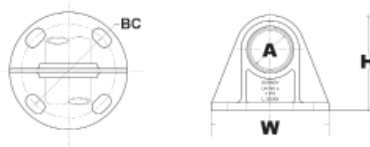

Catalog Number	Pipe Size	BC	H	W
OH17A3	1 1/2 IPS	3.00	4.38	4.25
OH17A5	1 1/2 IPS	5.00	4.81	6.25
OH18A3	2 IPS	3.00	4.38	4.25
OH18A5	2 IPS	5.00	5.13	6.25
OH19A3B	2 1/2 IPS	3.00	5.25	4.25
OH19A5	2 1/2 IPS	5.00	6.00	6.25
OH20A3	3 IPS	3.00	5.69	4.25
OH20A5	3 IPS	5.00	6.50	6.25
OH21A3	3 1/2 IPS	3.00	7.31	4.25
OH21A5	3 1/2 IPS	5.00	7.56	6.25
OH22A5	4 IPS		7.94	6.25
OH86A5	6 IPS		10.38	6.25

**TYPE NVHA
BUS SUPPORT**

For Use On VERTICAL PIPE
TO BASE

Aluminum alloy bus support for
mounting vertical tube on post or
pedestal insulators.

Material: Aluminum Alloy
Hardware: Aluminum Hardware

Notes :

- PENETROX™ A joint compound is recommended on contact surfaces
- Please contact factory for other sizes, combinations and availability.

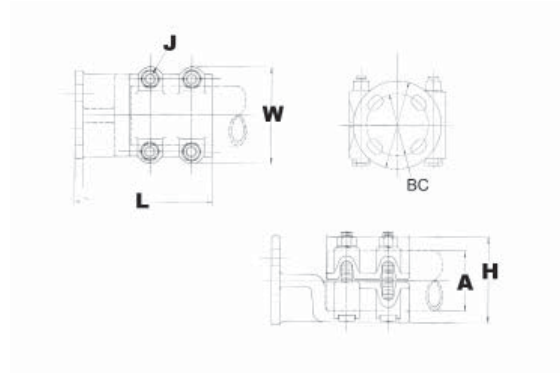

Catalog Number	A	BC	J Dia.	L	H	W
NVH14A3	3/4 IPS	3.00	1/2	4.07	1.52	2.44
NVH15A3	1 IPS			4.38	1.92	2.75
NVH15A5	1 IPS	5.00		4.38	1.92	2.75
NVH17A3	1 1/2 IPS	3.00		4.88	2.55	3.94
NVH18A3	2 IPS			4.88	3.06	4.62
NVH18A5	2 IPS	5.00		4.88	3.06	4.62
NVH22A3	4 IPS	3.00		6.62	4.69	6.25

**TYPE NSHG
BUS SUPPORT**

For Use On PIPE TO BASE

Aluminum alloy bus support for coupling same diameter tubes on post or pedestal insulators.

Material: Aluminum Alloy
Hardware: Aluminum Hardware

Notes :

- PENETROX™ A joint compound is recommended on contact surfaces
- Please contact factory for other sizes, combinations and availability

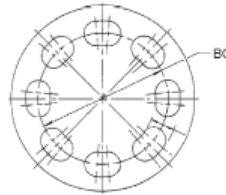
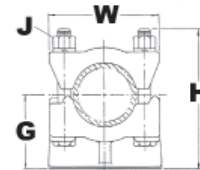
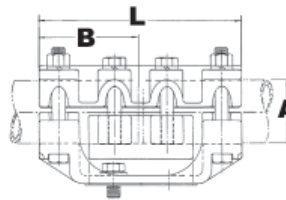

Catalog Number	A - tube	BC	G	J Dia.	B	L	H	W
NSHG16A3	1 1/4 IPS	3.00	2.25	1/2	4.00	7.56	4.06	3.50
NSHG17A3	1 1/2 IPS		2.50	1/2	4.00	7.66	4.62	3.78
NSHG18A3	2 IPS		2.75	1/2	4.00	8.13	5.25	4.25
NSHG18A5	2 IPS	5.00	2.87	1/2	4.00	10.12	4.62	4.08
NSHG19A3	2 1/2 IPS	3.00	3.12	1/2	4.00	8.13	5.50	4.62
NSHG20A5	3 IPS	5.00	3.62	5/8	5.00	10.60	6.69	5.62
NSHG21A5	3 1/2 IPS		4.00	5/8	5.00	10.56	6.94	6.13
NSHG22A5	4 IPS		4.50	5/8	5.00	11.34	7.81	6.62

**TYPE SUHK
BUS SUPPORT**

For Use On CABLE TO BASE

Streamlined aluminum alloy bus support for mounting cable on post or pedestal insulators.

EHV RATED: SELF-SHIELDING UP TO 550kV

Material: Aluminum Alloy
Hardware: Aluminum Hardware

Notes :

- PENETROX™ A joint compound is recommended on contact surfaces
- Please contact factory for other sizes, combinations and availability.

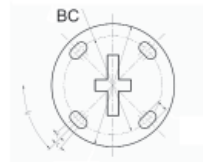
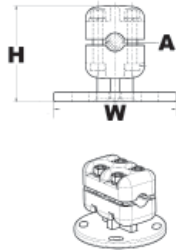

Catalog Number	Al Cable	ACSR Cable	BC	H	W
SUHK44ACG8	12 AWG	795 (54/7) Condor kcmil- 795 (26/7) Drake kcmil	5.00	4.83	3.50
SUHK46A5CG5	1400 kcmil- 1600 kcmil	1272 (54/19) Pheasant kcmil- 1431 (54/19) Plover kcmil		4.81	3.50
SUHK47A10S3HQ	12 AWG	1780 (84/19) Chukar kcmil	10.00	6.00	3.50
SUHK486ACG2	2250 kcmil- 2500 kcmil	N/A	5.00	5.25	3.62
SUHK48A5S3HQ	2000 kcmil			4.83	3.50
SUHK496A10S7HQ	4000 kcmil		10.00	7.40	5.75
SUHK496ACG2	4000 kcmil		5.00	5.75	4.50

**TYPE SUHG
BUS SUPPORT**

For Use On PIPE TO BASE

Streamlined aluminum alloy bus support for mounting tube on post or pedestal insulators. Caps are reversible for FIX or RIGID fit.

EHV RATED: SELF-SHIELDING UP TO 550kV

Material: Aluminum Alloy
Hardware: Aluminum Hardware

Notes :

- PENETROX™ A joint compound is recommended on contact surfaces
- Please contact factory for other sizes, combinations and availability.

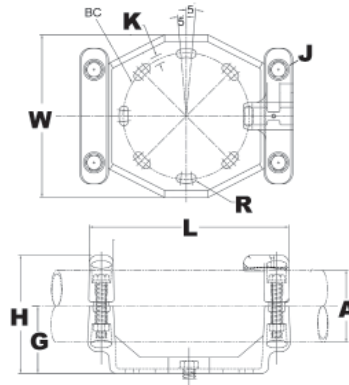

Catalog Number	A-Pipe Size	BC	G	J Dia.	L	H	W
SUHG20A5	3 IPS	5.00	3.62	5/8	11.25	6.25	7.92
SUHG20ACG6	3 IPS	6.00	3.75	5/8	10.62	6.47	5.75
SUHG20ACG6GS	3 IPS			5/8	10.62	6.47	5.75
SUHG21A7	3 1/2 IPS	7.00	4.00	5/8	13.50	66.95	10.06
SUHG22A10HQ	4 IPS	10.00	5.44	5/8	11.50	8.30	11.50
SUHG22A5	4 IPS	5.00	4.50	5/8	11.40	7.70	8.56
SUHG22A7	4 IPS	7.00		5/8	13.52	7.70	10.06
SUHG22ACG4	4 IPS	5.00	4.56	5/8	12.06	7.66	8.56
SUHG23A5CG1	4 1/2 IPS		5.32	5/8	13.71	8.46	9.68
SUHG24A5	5 IPS		5.00	5/8	11.54	8.80	9.68
SUHG24A5CG2	5 IPS		5.32	5/8	13.71	8.93	9.68
SUHG24A7	5 IPS	7.00	5.00	5/8	13.66	8.80	10.06
SUHG24A7GS	5 IPS			5/8	13.66	8.80	10.06
SUHG83A5	8 OD	5.00	6.59	5/8	11.76	11.66	12.16
SUHG83A7	8 OD	7.00		5/8	13.90	11.66	12.16
SUHG86A10B	6 IPS	10.00	5.50	5/8	16.88	9.83	12.88
SUHG86A10HQ	6 IPS		6.50	5/8	11.50	10.50	11.50
SUHG86A5	6 IPS	5.00	5.50	5/8	11.44	9.83	10.88
SUHG86A7	6 IPS	7.00		5/8	13.76	9.83	10.75

**TYPE SSXHP
BUS SUPPORT**

For Use On EXPANSION TUBE
COUPLER TO BASE

Streamlined guided expansion aluminum alloy bus support for coupling tube on post or pedestal type insulators. Alone, rated up to 230kV. Can be combined with SR family corona rings to reach 345kV (one ring) or 765kV (2 rings). Corona rings sold separately.

Material: Aluminum Alloy
Hardware: Aluminum Hardware

Notes :

- PENETROX™ A joint compound is recommended on contact surfaces
- Please contact factory for other sizes, combinations and availability
- Bus support couplers are supplied without bus end plugs. If end plugs are required add suffix "-EP" to catalog number.

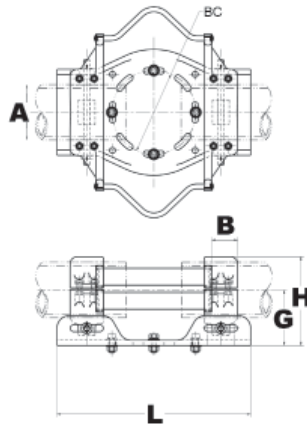

Catalog Number	A - Tube	B	BC	L	H	G
SSXHP22A10HQ	4 IPS	6.42	10.00	25.00	8.37	5.50
SSXHP83A5	8 OD		5.00	25.00	12.79	7.36
SSXHP83A7	8 OD		7.00	25.00	12.79	7.36
SSXHP86A10HQ	6 IPS		10.00	25.00	10.60	6.60

**TYPE XHP-A
EXPANSION COUPLER**

For Use On EXPANSION PIPE COUPLER TO BASE

Expansion coupler aluminum alloy bus support for coupling tube on post or pedestal type insulators.

Material: Aluminum Alloy
Hardware: Aluminum Hardware

Notes :

- Conductor smaller than 3 inch bus size is not recommended for 550kV
- Specify base mounting hardware, if required, by adding suffix -B to catalog number
- PENETROX™ A joint compound is recommended on contact surfaces
- Bus support couplers are supplied without bus end plugs. If end plugs are required add suffix “-EP” to catalog number

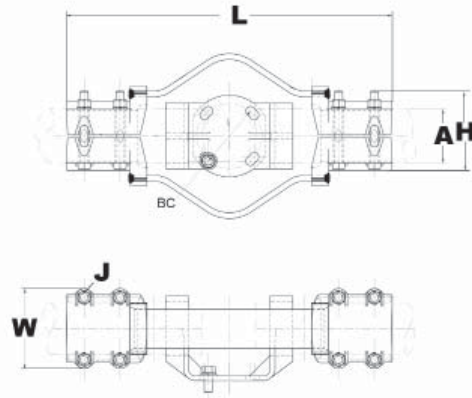
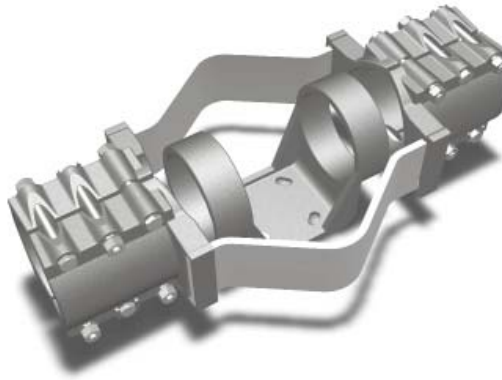

Catalog Number	Pipe Size Schd 40	Pipe Size Schd 80	L	J Dia.	H	W
XHP16A3	1 1/4 IPS	N/A	18.13	1/2	3.95	3.40
XHP16A5	1 1/4 IPS			1/2	4.08	3.40
XHP17A3	1 1/2 IPS		19.13	1/2	4.32	3.64
XHP17A5	1 1/2 IPS			1/2	4.32	3.64
XHP18A3	2 IPS		20.75	5/8	5.00	4.50
XHP19A3	2 1/2 IPS		21.88	5/8	5.62	5.00
XHP20A3	3 IPS		23.63	5/8	6.43	5.63
XHP20A5	3 IPS		26.00	5/8	6.43	5.63
XHP22A3	4 IPS		24.18	5/8	7.81	6.63
XHP22A5	4 IPS		26.25	5/8	7.81	6.63
XHP24A3	5 IPS		38.00	5/8	9.10	7.69
XHP24A5	5 IPS		29.56	5/8	9.10	7.69
XHP86A5	N/A	6 IPS	32.00	5/8	9.94	8.75
XHP90A5	N/A	3 IPS	24.18	5/8	6.43	5.63
XHP92A3	N/A	4 IPS	26.25	5/8	7.81	6.63
XHP92A5	N/A			5/8	7.81	6.63

**TYPE SXHP
STREAMLINED
EXPANSION COUPLER**

For Use On EXPANSION PIPE
COUPLER TO BASE

Streamlined expansion aluminum alloy
bus support for coupling tube on post
or pedestal type insulators.

**EHV RATED: SELF-SHIELDING UP
TO 550kV**

Material: Aluminum Alloy

Hardware: Aluminum Hardware

Notes :

- Conductor smaller than 3 inch bus size is not recommended for 550kV
- Specify base mounting hardware, if required, by adding suffix -B to catalog number
- PENETROX™ A joint compound is recommended on contact surfaces
- Bus support couplers are supplied without bus end plugs. If end plugs are required add suffix "-EP" to catalog number.

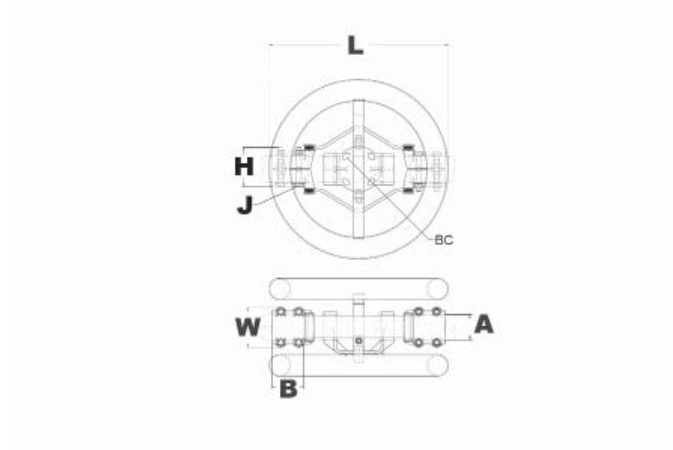

Catalog Number	Pipe Size Schd 80	BC	B	L	J Dia.	H	W
SXHP94A5	5 IPS	5.00	7.00	29.56	5/8	10.74	7.96

**TYPE SH2GBP-B2
SPACER**

For Use On (2) CABLES TO
INSULATOR POST

Streamlined rigid spacer for large range of cable with bus support mounting base. Particularly appropriate for 8"+ spacing. 2 bolts per clamping module version provide additional clamping strength.

EHV RATED: SELF-SHIELDING UP TO 550kV

Material: Aluminum Alloy
Hardware: Aluminum Hardware

Notes :

- PENETROX™ A joint compound is recommended on contact surfaces
- Please contact factory for other sizes, combinations and availability.

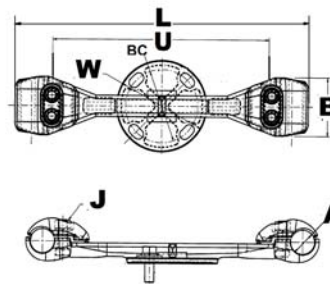
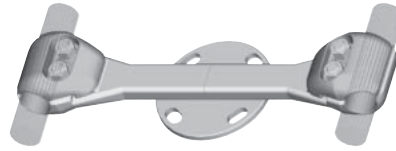

Catalog Number	Aluminum Stranded	Aluminum ACSR	J Dia.	U	L	BC	W
SH2GBP41A512B2	795 kcmil-874.5 kcmil	715.5 (24/7) Stilt	5/8	12.00	15.00	5.00	6.25
SH2GBP41A712B2	795 kcmil-874 kcmil	715.5 (24/7) Stilt kcmil		12.00	13.54	7.00	8.50
SH2GBP445A512B2	795 kcmil-874 kcmil			12.00	14.10	5.00	6.25
SH2GBP44A512B2	954 kcmil	795 (54/7) Condor kcmil		12.00	14.30	5.00	6.25
SH2GBP45A512B2	1192 kcmil-1272 kcmil	1033.5 (54/7) Curlew kcmil-1192.5 (54/19) Grackle kcmil		12.00	14.30	5.00	6.25
SH2GBP486A5B2	2300 kcmil-2500 kcmil	2167 (72/7) Kiwi-2156 (84/19) Bluebird		18.00	14.30	5.00	6.25
SH2GBP48A512B2	1700 kcmil-2000 kcmil	1590 (45/7) Lapwing kcmil-1780 (84/19) Chukar kcmil		12.00	14.30	5.00	6.25
SH2GBP48A5B2	1750 kcmil-2000 kcmil			18.00	14.30	5.00	6.25
SH2GBP48A712B2	1750 kcmil-2000 kcmil			12.00	14.30	7.00	8.50
SH2GBP48A7B2	1750 kcmil-2000 kcmil			18.00	20.30	7.00	4.00

**TYPE SH2GBP-B4
SPACER**

For Use On (2) CABLES TO
INSULATOR POST

Streamlined rigid spacer for large range of cables with bus support mounting base. Particularly appropriate for 8"+ spacing. Version with 4 bolts per clamping module - 2 on each side - for ideal clamping of the cable.

Material: Aluminum Alloy
Hardware: Aluminum Hardware

Notes :

- PENETROX™ A joint compound is recommended on contact surfaces
- Please contact factory for other sizes, combinations and availability.

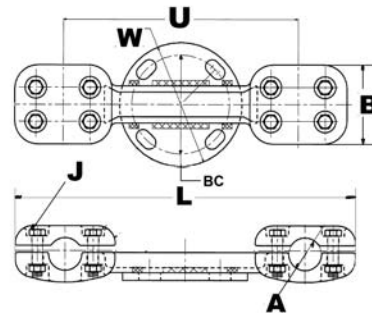
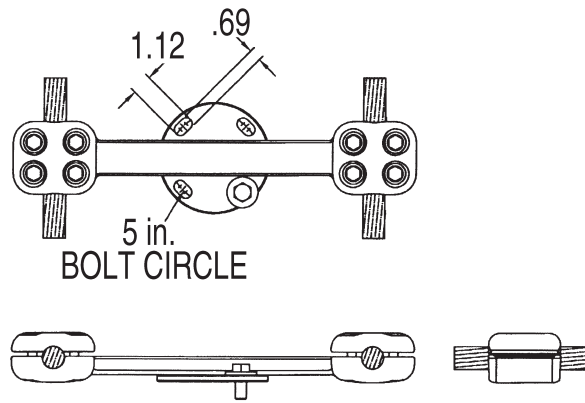

Catalog Number	Aluminum Stranded	Aluminum ACSR	B	J Dia.	U	L	BC	W
SH2GBP445A515B4	1033.5 kcmil- 1113 kcmil	954 (45/7) Rail- 1033.5 (45/7) Ortolan	4.00	1/2	15.00	19.60	5.00	6.25
SH2GBP44A512B4	954 kcmil	795 (54/7) Condor kcmil- 874.5 (54/7) Crane kcmil		1/2	12.00	14.30	5.00	6.25
SH2GBP486A512B4	2300 kcmil- 2500 kcmil	2167 (72/7) Kiwi- 2156 (84/19) Bluebird		1/2	12.00	15.00	5.00	6.25
SH2GBP486A5B4	2300 kcmil- 2500 kcmil	2156 (84/19) Bluebird kcmil- 2167 (72/7) Kiwi kcmil		1/2	18.00	20.30	5.00	6.25
SH2GBP48A512B4	1750 kcmil- 2000 kcmil	1590 (45/7) Lapwing kcmil- 1780 (84/19) Chukar kcmil		1/2	12.00	14.30	5.00	6.25
SH2GBP48A5B4	1750 kcmil- 2000 kcmil		5.00	1/2	18.00	23.00	5.00	6.25

**TYPE SH2GBP
SPACER**

For Use On (2) CABLES TO
INSULATOR POST

Streamlined rigid spacer for large range of cable with bus support mounting base. Particularly appropriate for 8"+ spacing. 1 bolt per clamping module version.

EHV RATED: SELF-SHIELDING UP TO 550kV

Material: Aluminum Alloy
Hardware: Aluminum Hardware

Notes :

- PENETROX™ A joint compound is recommended on contact surfaces
- Please contact factory for other sizes, combinations and availability.

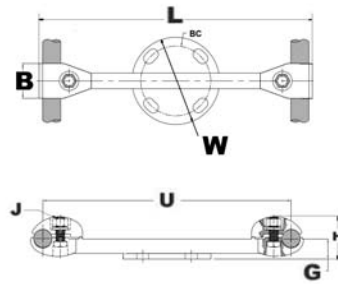
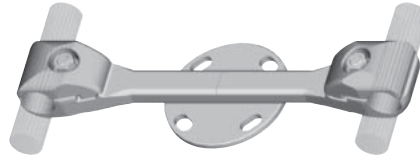

Catalog Number	Aluminum Stranded	Aluminum ACSR	B	J Dia.	U	L	H	BC	G	W
SH2GBP41A5	795 kcmil-874 kcmil	795 (54/7) Condor kcmil	3.00	5/8	18.00	19.71	2.85	5.00	1.50	6.25
SH2GBP41A512	795 kcmil-874 kcmil		3.00	5/8	12.00	13.71	2.85	5.00	1.50	6.25
SH2GBP445A512	1033 kcmil-1113 kcmil	954 (45/7) Rail kcmil-1033.5 (45/7) Ortolan kcmil	3.00	5/8	12.00	14.10	2.6	5.00	1.35	6.25
SH2GBP45A5	1192 kcmil-1272 kcmil	1033.5 (54/7) Curlew kcmil-1192.5 (54/19) Grackle kcmil	3.00	5/8	18.00	18.00	2.85	5.00	1.50	6.25
SH2GBP45A512	1192 kcmil-1272 kcmil		3.00	5/8	12.00	13.84	2.85	5.00	1.50	6.25
SH2GBP46A5	1590 kcmil-1600 kcmil	1272 (54/19) Pheasant kcmil-1431 (54/19) Plover kcmil	3.00	5/8	18.00	20.30	2.88	5.00	1.50	6.25
SH2GBP46A512	1590 kcmil-1600 kcmil	1272 (54/19) Pheasant-1431 (54/19) Plover	3.00	5/8	12.00	12.00	2.88	5.00	1.50	6.25
SH2GBP486A7	2300 kcmil-2500 kcmil	2167 (72/7) Kiwi-2156 (84/19) Bluebird	3.00	5/8	18.00	20.30	2.56	7.00	1.50	8.50
SH2GBP48A5	1750 kcmil-2000 kcmil	1590 (45/7) Lapwing kcmil-1780 (84/19) Chukar kcmil	3.00	5/8	18.00	18.00	2.56	5.00	1.50	6.25
SH2GBP48A512	1750 kcmil-2000 kcmil	1590 (45/7) Lapwing kcmil-1780 (54/19) kcmil	3.00	5/8	12.00	14.30	2.56	5.00	1.50	6.25
SH2GBP48A7	1750 kcmil-2000 kcmil	1590 (45/7) Lapwing kcmil-1780 (84/19) Chukar kcmil	3.00	5/8	18.00	20.30	2.56	7.00	1.50	8.50
SH2GBP495A58	3500 kcmil	N/A	3.00	3/4	8.00	10.70	3.85	5.00	2.00	6.25

Table of Contents - Aluminum T Connectors

	Type NNT Pipe to Pipe	A-81
	Type NNTR Cable to Cable	A-83
	Type NNTR Pipe to Cable	A-86
	Type NN2TR Pipe to 2 Cables	A-89
	Type NBC-A Pipe to Pad	A-90
	Type NBCR Cable to Pad Bundle	A-92
	Type N2BCR 2 Cables to Pad	A-94
	Type XTA Expansion Pipe to Pipe	A-95
	Type SNNT Pipe or Cable Run to Pipe or Cable Tap	A-96
	Type SSNTV Pipe to Pipe with Variable Angle	A-99
	Type SNBC Pipe or Cable Run to Tap Pad	A-100
	Type SN2B 2 Cable Run to Tap Pad	A-103
	Type S2GBPA Rigid Spacer Run to Tap Pad	A-104
	Type S2GBPA-B2 Rigid Spacer Run to Tap Pad	A-105
	Type S2GBPA-B4 Rigid Cable Spacer with Tap Pad	A-106



**TYPE NNT
T-CONNECTOR**

For Use On TUBE TO TUBE

Aluminum alloy T-Connector for tubing run and tap. Properly proportioned to permit use on copper-aluminum conductor combinations. Captured hex head bolts permit one-wrench installation.



Material: Aluminum Alloy
Hardware: Aluminum Hardware

Notes :

- PENETROX™ A joint compound is recommended on contact surfaces
- Please contact factory for other sizes, combinations and availability
- One-wrench installation.
- V-bolt clamping element is particularly appropriate for flexible cables

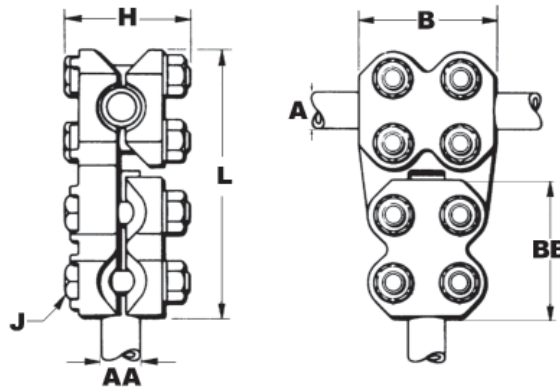

Catalog Number	A - Run tube	AA - Tap tube	B	J Dia.	BB	L	H
NNT14A14A	3/4 IPS	3/4 IPS	3.25	1/2	3.25	6.31	3.13
NNT15A14A	1 IPS	3/4 IPS	3.50	1/2	3.25	6.56	3.38
NNT15A15A		1 IPS	3.50	1/2	3.50	6.81	3.38
NNT16A14A	1 1/4 IPS	3/4 IPS	3.75	1/2	3.25	6.94	3.38
NNT16A15A		1 IPS	3.75	1/2	3.50	7.19	3.38
NNT16A16A		1 1/4 IPS	3.75	1/2	3.75	7.44	3.38
NNT17A14A	1 1/2 IPS	3/4 IPS	4.00	1/2	3.25	7.19	3.88
NNT17A15A		1 IPS	4.00	1/2	3.50	7.38	3.88
NNT17A17A		1 1/2 IPS	4.00	1/2	4.00	7.88	3.88
NNT18A14A	2 IPS	3/4 IPS	4.00	1/2	3.25	7.69	4.38
NNT18A15A		1 IPS	4.00	1/2	3.50	7.94	4.38
NNT18A16A		1 1/4 IPS	4.00	1/2	3.75	8.06	4.38
NNT18A17A		1 1/2 IPS	4.00	1/2	4.00	8.44	4.38
NNT18A18A		2 IPS	4.25	5/8	4.25	9.06	4.44
NNT19A14A	2 1/2 IPS	3/4 IPS	4.00	1/2	3.25	8.12	4.31
NNT19A15A		1 IPS	4.00	1/2	3.50	8.44	4.38
NNT19A16A		1 1/4 IPS	4.00	1/2	3.75	8.69	4.38
NNT19A17A		1 1/2 IPS	4.00	1/2	4.00	8.94	4.38
NNT19A18A		2 IPS	4.50	5/8	4.25	9.13	4.94
NNT19A19A		2 1/2 IPS	4.50	5/8	4.50	9.38	4.94

TYPE NNT T-CONNECTOR (Continued)

For Use On TUBE TO TUBE



Catalog Number	A - Run tube	AA - Tap tube	B	J Dia.	BB	L	H
NNT20A15A	3 IPS	1 IPS	4.00	1/2	3.50	9.06	5.00
NNT20A16A		1 1/4 IPS	4.00	1/2	3.75	9.31	5.00
NNT20A17A		1 1/2 IPS	4.00	1/2	4.00	9.19	5.00
NNT20A18A		2 IPS	5.00	5/8	4.25	10.19	5.44
NNT20A19A		2 1/2 IPS	5.00	5/8	4.50	10.44	5.44
NNT20A20A		3 IPS	5.00	5/8	5.00	10.94	5.44
NNT21A17A	3 1/2 IPS	1 1/2 IPS	4.00	1/2	4.00	10.13	5.19
NNT21A18A		2 IPS	5.50	5/8	4.25	10.88	5.56
NNT21A19A		2 1/2 IPS	5.50	5/8	4.50	11.06	5.56
NNT21A20A		3 IPS	5.50	5/8	5.00	11.06	5.56
NNT21A21A		3 1/2 IPS	5.50	5/8	5.50	12.06	5.56
NNT22A15A	4 IPS	1 IPS	4.00	1/2	3.50	10.13	5.75
NNT22A16A		1 1/4 IPS	6.06	1/2	3.75	11.30	5.94
NNT22A17A		1 1/2 IPS	4.00	1/2	4.00	10.38	5.75
NNT22A18A		2 IPS	6.00	5/8	4.25	10.88	6.19
NNT22A19A		2 1/2 IPS	6.00	5/8	4.50	11.13	6.19
NNT22A22A		4 IPS	6.00	5/8	6.00	12.63	6.19
NNT24A18A	5 IPS	2 IPS	6.00	5/8	4.25	12.19	6.94
NNT24A19A	5 IPS	2 1/2 IPS	6.00	5/8	4.50	12.56	6.94
NNT24A20A		3 IPS	6.00	5/8	5.00	13.06	6.94
NNT24A22A	5 IPS	4 IPS	6.00	5/8	6.00	14.06	6.94
NNT24A24A		5 IPS	7.00	5/8	7.00	15.06	6.94
NNT86A18A	6 IPS	2 IPS	6.00	5/8	4.25	15.38	8.00
NNT86A20A	6 IPS	3 IPS	6.00	5/8	5.00	14.13	8.00
NNT86A22A		4 IPS	6.00	5/8	6.00	15.13	8.00
NNT86A86A		6 IPS	8.00	5/8	8.00	17.13	8.00

**TYPE NNTR
T-CONNECTOR**

For Use On CABLE TO CABLE

Aluminum alloy T-Connector for a range of cable run to range of cable tap. One-wrench installation.

Material: Aluminum Alloy
Hardware: Aluminum Hardware

Notes :

- PENETROX™ A joint compound is recommended on contact surfaces
- Please contact factory for other sizes, combinations and availability
- One-wrench installation.

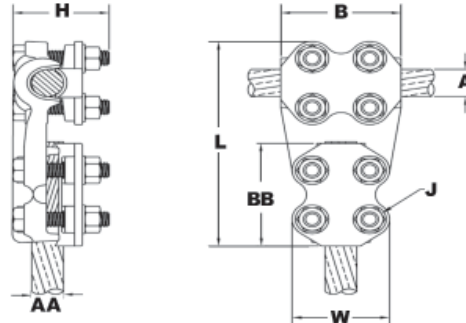

Catalog Number	A - Run Al Cable	A - Run ACSR Cable	AA - Tap Al Cable	AA - Tap ACSR Cable	B	J Dia.	BB	L	H	W
NNTR25A25A	4 AWG- 1/0 AWG	4 (6/1) Swan AWG- 1/0 (6/1) Raven AWG	4 AWG- 1/0 AWG	4 (6/1) Swan AWG- 1/0 (6/1) Raven AWG	1.88	1/2	1.88	4.50	2.31	2.31
NNTR29A29A	1/0 AWG- 250 kcmil	1/0 (6/1) Raven AWG- 4/0 (6/1) Penquin AWG	1/0 AWG- 250 kcmil	1/0 (6/1) Raven AWG- 4/0 (6/1) Penquin AWG	2.75	1/2	2.75	5.56	2.56	2.50
NNTR32A25A	250 kcmil- 400 kcmil	4/0 (6/1) Penquin AWG- 397.5 (18/1) Chickadee kcmil	4 AWG- 1/0 AWG	4 (6/1) Swan AWG- 1/0 (6/1) Raven AWG	1.88	1/2	1.88	4.81	2.56	2.28
NNTR32A29A	250 kcmil- 400 kcmil	4/0 (6/1) Penquin AWG- 397.5 (18/1) Chickadee kcmil	1/0 AWG- 250 kcmil	1/0 (6/1) Raven AWG- 4/0 (6/1) Penquin AWG	3.00	1/2	2.75	5.69	2.56	2.50
NNTR32A32A	250 kcmil- 400 kcmil	4/0 (6/1) Penquin AWG- 397.5 (18/1) Chickadee kcmil	250 kcmil- 400 kcmil	4/0 (6/1) Penquin AWG- 397.5 (18/1) Chickadee kcmil	3.00	1/2	3.00	5.94	2.56	2.63
NNTR36A25A	350 kcmil- 600 kcmil	336.4 (18/1) Merlin kcmil- 477.0 (18/1) Pelican kcmil	4 AWG- 1/0 AWG	4 (6/1) Swan AWG- 1/0 (6/1) Raven AWG	1.88	1/2	1.88	4.94	2.56	2.31
NNTR36A29A	350 kcmil- 600 kcmil	336.4 (18/1) Merlin kcmil- 477.0 (18/1) Pelican kcmil	1/0 AWG- 250 kcmil	1/0 (6/1) Raven AWG- 4/0 (6/1) Penquin AWG	3.25	1/2	2.75	5.31	2.56	2.50
NNTR36A32A	350 kcmil- 600 kcmil	336.4 (18/1) Merlin kcmil- 477.0 (18/1) Pelican kcmil	250 kcmil- 400 kcmil	4/0 (6/1) Penquin AWG-3 97.5 (18/1) Chickadee kcmil	3.25	1/2	3.00	6.06	2.56	2.63
NNTR36A36A	350 kcmil- 600 kcmil	336.4 (18/1) Merlin kcmil- 477.0 (18/1) Pelican kcmil	350 kcmil- 600 kcmil	336.4 (18/1) Merlin kcmil- 477.0 (18/1) Pelican kcmil	3.25	1/2	3.25	6.31	2.56	2.75
NNTR42A25A	600 kcmil- 900 kcmil	477.0 (18/1) Pelican kcmil- 795 (54/7) Condor kcmil	4 AWG- 1/0 AWG	4 (6/1) Swan AWG- 1/0 (6/1) Raven AWG	1.88	1/2	1.88	5.25	3.13	2.31

TYPE NNTR T-CONNECTOR (Continued)



For Use On CABLE TO CABLE

Catalog Number	A - Run AI Cable	A - Run ACSR Cable	AA - Tap AI Cable	AA - Tap ACSR Cable	B	J Dia.	BB	L	H	W
NNTR42A29A	600 kcmil- 900 kcmil	477.0 (18/1) Pelican kcmil- 795 (54/7) Condor kcmil	1/0 AWG- 250 kcmil	1/0 (6/1) Raven AWG- 4/0 (6/1) Penguin AWG	3.50	1/2	2.75	6.13	3.13	2.50
NNTR42A32A	600 kcmil- 900 kcmil	477.0 (18/1) Pelican kcmil- 795 (54/7) Condor kcmil	250 kcmil- 400 kcmil	4/0 (6/1) Penguin AWG- 397.5 (18/1) Chickadee kcmil	3.50	1/2	3.00	6.38	3.13	2.63
NNTR42A36A	600 kcmil- 900 kcmil	477.0 (18/1) Pelican kcmil- 795 (54/7) Condor kcmil	350 kcmil- 600 kcmil	336.4 (18/1) Merlin kcmil- 477.0 (18/1) Pelican kcmil	3.50	1/2	3.25	6.63	3.13	2.75
NNTR42A42A	600 kcmil- 900 kcmil	477.0 (18/1) Pelican kcmil- 795 (54/7) Condor kcmil	600 kcmil- 900 kcmil	477.0 (18/1) Pelican kcmil- 795 (54/7) Condor kcmil	3.50	1/2	3.50	6.88	3.13	3.00
NNTR45A25A	900 kcmil- 1250 kcmil	715.5 (54/7) Crow kcmil- 1113 (54/19) Finch kcmil	4 AWG- 1/0 AWG	4 (6/1) Swan AWG- 1/0 (6/1) Raven AWG	3.75	1/2	2.75	5.63	3.25	2.50
NNTR45A29A	900 kcmil- 1250 kcmil	715.5 (54/7) Crow kcmil- 1113 (54/19) Finch kcmil	1/0 AWG- 250 kcmil	1/0 (6/1) Raven AWG- 4/0 (6/1) Penguin AWG	3.75	1/2	2.75	6.19	3.25	2.50
NNTR45A32A	900 kcmil- 1250 kcmil	715.5 (54/7) Crow kcmil- 1113 (54/19) Finch kcmil	250 kcmil- 400 kcmil	4/0 (6/1) Penguin AWG- 397.5 (18/1) Chickadee kcmil	3.75	1/2	3.00	6.56	3.25	2.63
NNTR45A36A	900 kcmil- 1250 kcmil	715.5 (54/7) Crow kcmil- 1113 (54/19) Finch kcmil	350 kcmil- 600 kcmil	336.4 (18/1) Merlin kcmil- 477.0 (18/1) Pelican kcmil	3.75	1/2	3.25	6.81	3.25	2.75
NNTR45A42A	900 kcmil- 1250 kcmil	715.5 (54/7) Crow kcmil- 1113 (54/19) Finch kcmil	600 kcmil- 900 kcmil	477.0 (18/1) Pelican kcmil- 795 (54/7) Condor kcmil	3.75	1/2	3.50	7.06	3.25	3.00
NNTR45A45A	900 kcmil- 1250 kcmil	715.5 (54/7) Crow kcmil- 1113 (54/19) Finch kcmil	900 kcmil- 1250 kcmil	715.5 (54/7) Crow kcmil- 1113 (54/19) Finch kcmil	3.75	1/2	3.75	7.31	3.25	3.19
NNTR46A25A	1250 kcmil- 1600 kcmil	1113 (54/19) Finch kcmil- 1431 (54/19) Plover kcmil	4 AWG- 1/0 AWG	4 (6/1) Swan AWG- 1/0 (6/1) Raven AWG	1.88	1/2	1.88	5.50	3.44	2.31
NNTR46A29A	1250 kcmil- 1600 kcmil	1113 (54/19) Finch kcmil- 1431 (54/19) Plover kcmil	1/0 AWG- 250 kcmil	1/0 (6/1) Raven AWG- 4/0 (6/1) Penguin AWG	3.75	1/2	2.75	5.88	3.44	2.63
NNTR46A32A	1250 kcmil- 1600 kcmil	1113 (54/19) Finch kcmil- 1431 (54/19) Plover kcmil	250 kcmil- 400 kcmil	4/0 (6/1) Penguin AWG- 397.5 (18/1) Chickadee kcmil	4.50	1/2	3.12	6.91	3.44	2.63
NNTR46A36A	1250 kcmil- 1600 kcmil	1113 (54/19) Finch kcmil- 1431 (54/19) Plover kcmil	350 kcmil- 600 kcmil	336.4 (18/1) Merlin kcmil- 477.0 (18/1) Pelican kcmil	3.75	1/2	3.25	6.94	3.44	2.75
NNTR46A42A	1250 kcmil- 1600 kcmil	1113 (54/19) Finch kcmil- 1431 (54/19) Plover kcmil	600 kcmil- 900 kcmil	477.0 (18/1) Pelican kcmil- 795 (54/7) Condor kcmil	3.75	1/2	3.50	7.25	3.44	3.00
NNTR46A45A	1250 kcmil- 1600 kcmil	1113 (54/19) Finch kcmil- 1431 (54/19) Plover kcmil	900 kcmil- 1250 kcmil	715.5 (54/7) Crow kcmil- 1113 (54/19) Finch kcmil	3.75	1/2	3.75	7.50	3.44	3.19
NNTR46A46A	1250 kcmil- 1600 kcmil	1113 (54/19) Finch kcmil- 1431 (54/19) Plover kcmil	1250 kcmil- 1600 kcmil	1113 (54/19) Finch kcmil- 1431 (54/19) Plover kcmil	4.38	5/8	4.38	8.31	3.69	3.75

**TYPE NNTR
T-CONNECTOR**
(Continued)



For Use On CABLE TO CABLE

Catalog Number	A - Run Al Cable	A - Run ACSR Cable	AA - Tap Al Cable	AA - Tap ACSR Cable	B	J Dia.	BB	L	H	W
NNTR486A36A	2000 kcmil- 2500 kcmil	N/A	350 kcmil- 600 kcmil	336.4 (18/1) Merlin kcmil- 477.0 (18/1) Pelican kcmil	3.75	1/2	3.25	7.59	3.88	2.75
NNTR48A36A	1500 kcmil- 2000 kcmil	1272 (54/19) Pheasant kcmil- 1780 (54/19) kcmil	350 kcmil- 600 kcmil	336.4 (18/1) Merlin kcmil- 477.0 (18/1) Pelican kcmil	3.75	1/2	3.25	7.19	3.81	2.75
NNTR48A42A	1500 kcmil- 2000 kcmil	1272 (54/19) Pheasant kcmil- 1780 (54/19) kcmil	600 kcmil- 900 kcmil	477.0 (18/1) Pelican kcmil- 795 (54/7) Condor kcmil	4.62	1/2	3.62	7.38	3.81	3.00
NNTR48A46A	1500 kcmil- 2000 kcmil	1272 (54/19) Pheasant kcmil- 1780 (54/19) kcmil	1250 kcmil- 1600 kcmil	1113 (54/19) Finch kcmil- 1431 (54/19) Plover kcmil	4.50	5/8	4.38	8.50	3.81	3.75
NNTR48A486A	1500 kcmil- 2000 kcmil	1272 (54/19) Pheasant kcmil- 1780 (54/19) kcmil	2000 kcmil- 2500 kcmil	2156 (64/119) kcmil	4.50	5/8	4.62	8.88	4.19	4.12
NNTR48A48A	1500 kcmil- 2000 kcmil	1272 (54/19) Pheasant kcmil- 1780 (54/19) kcmil	1500 kcmil- 2000 kcmil	1272 (54/19) Pheasant kcmil- 1780 (54/19) kcmil	4.50	5/8	4.50	8.63	3.81	3.88

**TYPE NNTR
T-CONNECTOR**

For Use On TUBE TO CABLE

Aluminum alloy T-Connector for tube run, range of cable tap. Properly proportioned to permit use on copper-aluminum combinations. One-wrench installation. PENETROX™ joint compound recommended on contact surfaces.



Material: Aluminum Alloy
Hardware: Aluminum Hardware

Notes :

- PENETROX™ A joint compound is recommended on contact surfaces
- Please contact factory for other sizes, combinations and availability
- One-wrench installation.

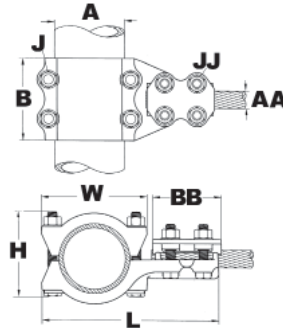

Catalog Number	A - Run Al Pipe	AA - Tap Al Cable	AA - Tap ACSR Cable	B	J Dia.	BB	L	H	JJ Dia.	W
NNTR13A25A	1/2 IPS	4 AWG-1/0 AWG	4 (6/1) Swan AWG-1/0 (6/1) Raven AWG	1.88	1/2	1.88	4.69	2.81	1/2	2.31
NNTR14A25A	3/4 IPS	4 AWG-1/0 AWG	4 (6/1) Swan AWG-1/0 (6/1) Raven AWG	3.25	1/2	2.00	4.94	3.06	1/2	2.31
NNTR14A29A	3/4 IPS	1/0 AWG-250 kcmil	1/0 (6/1) Raven AWG-4/0 (6/1) Penguin AWG	3.25	1/2	2.75	5.81	3.06	1/2	2.50
NNTR14A32A	3/4 IPS	250 kcmil-400 kcmil	4/0 (6/1) Penguin AWG-397.5 (18/1) Chickadee kcmil	3.25	1/2	3.12	6.06	3.06	1/2	2.64
NNTR32A25A	3/4 IPS	350 kcmil-600 kcmil	336.4 (18/1) Merlin kcmil-477.0 (18/1) Pelican kcmil	3.25	1/2	3.25	6.31	3.06	1/2	2.75
NNTR15A25A	1 IPS	4 AWG-1/0 AWG	4 (6/1) Swan AWG-1/0 (6/1) Raven AWG	1.88	1/2	1.88	5.19	3.31	1/2	2.28
NNTR15A29A	1 IPS	1/0 AWG-250 kcmil	1/0 (6/1) Raven AWG-4/0 (6/1) Penguin AWG	3.50	1/2	2.75	6.06	3.31	1/2	2.50
NNTR15A32A	1 IPS	250 kcmil-400 kcmil	4/0 (6/1) Penguin AWG-397.5 (18/1) Chickadee kcmil	3.50	1/2	3.00	6.31	3.31	1/2	2.63
NNTR15A36A	1 IPS	350 kcmil-600 kcmil	336.4 (18/1) Merlin kcmil-477.0 (18/1) Pelican kcmil	3.50	1/2	3.25	6.56	3.31	1/2	2.75
NNTR15A42A	1 IPS	600 kcmil-900 kcmil	477.0 (18/1) Pelican kcmil-795 (54/7) Condor kcmil	3.50	1/2	3.50	6.81	3.31	1/2	3.00
NNTR16A29A	1 1/4 IPS	1/0 AWG-250 kcmil	1/0 (6/1) Raven AWG-4/0 (6/1) Penguin AWG	3.75	1/2	2.75	6.44	3.31	1/2	2.50
NNTR16A32A	1 1/4 IPS	250 kcmil-400 kcmil	4/0 (6/1) Penguin AWG-397.5 (18/1) Chickadee kcmil	3.75	1/2	3.12	6.69	3.31	1/2	2.63
NNTR16A36A	1 1/4 IPS	350 kcmil-600 kcmil	336.4 (18/1) Merlin kcmil-477.0 (18/1) Pelican kcmil	3.75	1/2	3.25	6.94	3.31	1/2	2.75
NNTR16A42A	1 1/4 IPS	600 kcmil-900 kcmil	477.0 (18/1) Pelican kcmil-795 (54/7) Condor kcmil	3.75	1/2	3.50	7.19	3.31	1/2	3.00

TYPE NNTR T-CONNECTOR (Continued)



For Use On TUBE TO CABLE

Catalog Number	A - Run Al Pipe	AA - Tap Al Cable	AA - Tap ACSR Cable	B	J Dia.	BB	L	H	JJ Dia.	W
NNTR17A29A	1 1/2 IPS	1/0 AWG-250 kcmil	1/0 (6/1) Raven AWG-4/0 (6/1) Penquin AWG	4.00	1/2	2.75	6.69	3.81	1/2	2.50
NNTR17A32A	1 1/2 IPS	250 kcmil-400 kcmil	4/0 (6/1) Penquin AWG-397.5 (18/1) Chickadee kcmil	4.00	1/2	3.00	6.94	3.81	1/2	2.63
NNTR17A36A	1 1/2 IPS	350 kcmil-600 kcmil	336.4 (18/1) Merlin kcmil-477.0 (18/1) Pelican kcmil	4.00	1/2	3.25	7.19	3.81	1/2	2.75
NNTR17A42A	1 1/2 IPS	600 kcmil-900 kcmil	477.0 (18/1) Pelican kcmil-795 (54/7) Condor kcmil	4.00	1/2	3.50	7.44	3.81	1/2	3.00
NNTR17A45A	1 1/2 IPS	900 kcmil-1250 kcmil	715.5 (54/7) Crow kcmil-1113 (54/19) Finch kcmil	4.00	1/2	3.75	7.69	3.81	1/2	3.19
NNTR17A48A	1 1/2 IPS	1500 kcmil-2000 kcmil	1272 (54/19) Pheasant kcmil-1780 (54/19) kcmil	4.50	5/8	4.50	8.94	3.91	5/8	3.88
NNTR18A29A	2 IPS	1/0 AWG-250 kcmil	1/0 (6/1) Raven AWG-4/0 (6/1) Penquin AWG	4.00	1/2	2.75	7.56	4.44	1/2	2.50
NNTR18A32A	2 IPS	250 kcmil-400 kcmil	4/0 (6/1) Penquin AWG-397.5 (18/1) Chickadee kcmil	4.00	1/2	3.00	7.81	4.44	1/2	2.63
NNTR18A36A	2 IPS	350 kcmil-600 kcmil	336.4 (18/1) Merlin kcmil-477.0 (18/1) Pelican kcmil	4.00	1/2	3.25	8.06	4.44	1/2	2.75
NNTR18A42A	2 IPS	600 kcmil-900 kcmil	477.0 (18/1) Pelican kcmil-795 (54/7) Condor kcmil	4.00	1/2	3.50	8.31	4.44	1/2	3.00
NNTR18A45A	2 IPS	900 kcmil-1250 kcmil	715.5 (54/7) Crow kcmil-1113 (54/19) Finch kcmil	4.00	1/2	3.75	8.56	4.44	1/2	3.19
NNTR19A29A	2 1/2 IPS	1/0 AWG-250 kcmil	1/0 (6/1) Raven AWG-4/0 (6/1) Penquin AWG	4.00	1/2	2.75	8.13	4.56	1/2	2.50
NNTR19A32A	2 1/2 IPS	250 kcmil-400 kcmil	4/0 (6/1) Penquin AWG-397.5 (18/1) Chickadee kcmil	4.00	1/2	3.00	8.38	4.56	1/2	2.63
NNTR19A36A	2 1/2 IPS	350 kcmil-600 kcmil	336.4 (18/1) Merlin kcmil-477.0 (18/1) Pelican kcmil	4.00	1/2	3.25	8.63	4.56	1/2	2.75
NNTR19A42A	2 1/2 IPS	600 kcmil-900 kcmil	477.0 (18/1) Pelican kcmil-795 (54/7) Condor kcmil	4.00	5/8	3.50	8.88	5.00	5/8	3.00
NNTR19A45A	2 1/2 IPS	900 kcmil-1250 kcmil	715.5 (54/7) Crow kcmil-1113 (54/19) Finch kcmil	4.00	1/2	3.75	9.13	4.56	1/2	3.19
NNTR19A46A	2 1/2 IPS	1250 kcmil-1600 kcmil	1113 (54/19) Finch kcmil-1431 (54/19) Plover kcmil	4.50	5/8	4.38	9.75	4.94	5/8	3.75
NNTR19A48A	2 1/2 IPS	1500 kcmil-2000 kcmil	1272 (54/19) Pheasant kcmil-1780 (54/19) kcmil	4.50	5/8	4.50	9.88	4.94	5/8	3.88
NNTR20A29A	3 IPS	1/0 AWG-250 kcmil	1/0 (6/1) Raven AWG-4/0 (6/1) Penquin AWG	4.00	1/2	2.75	8.75	5.44	1/2	2.50
NNTR20A32A	3 IPS	250 kcmil-400 kcmil	4/0 (6/1) Penquin AWG-397.5 (18/1) Chickadee kcmil	4.00	1/2	3.00	9.00	5.44	1/2	2.63
NNTR20A36A	3 IPS	350 kcmil-600 kcmil	336.4 (18/1) Merlin kcmil-477.0 (18/1) Pelican kcmil	4.00	1/2	3.25	9.25	5.44	1/2	2.75
NNTR20A42A	3 IPS	600 kcmil-900 kcmil	477.0 (18/1) Pelican kcmil-795 (54/7) Condor kcmil	4.00	1/2	3.50	9.50	5.44	1/2	3.00
NNTR20A45A	3 IPS	900 kcmil-1250 kcmil	715.5 (54/7) Crow kcmil-1113 (54/19) Finch kcmil	4.00	1/2	3.75	9.75	5.44	1/2	3.19
NNTR20A46A	3 IPS	1250 kcmil-1600 kcmil	1113 (54/19) Finch kcmil-1431 (54/19) Plover kcmil	5.00	5/8	4.38	10.38	5.44	5/8	3.34
NNTR20A48A	3 IPS	1500 kcmil-2000 kcmil	1272 (54/19) Pheasant kcmil-1780 (54/19) kcmil	5.00	5/8	4.50	10.50	5.44	5/8	3.88

**TYPE NNTR
T-CONNECTOR**
(Continued)



For Use On TUBE TO CABLE

Catalog Number	A - Run Al Pipe	AA - Tap Al Cable	AA - Tap ACSR Cable	B	J Dia.	BB	L	H	JJ Dia.	W
NNTR21A32A	3 1/2 IPS	250 kcmil-400 kcmil	4/0 (6/1) Penquin AWG-397.5 (18/1) Chickadee kcmil	4.00	1/2	3.00	9.13	5.13	1/2	2.63
NNTR21A36A	3 1/2 IPS	350 kcmil-600 kcmil	336.4 (18/1) Merlin kcmil-477.0 (18/1) Pelican kcmil	4.00	1/2	3.25	9.38	5.44	1/2	2.75
NNTR21A42A	3 1/2 IPS	600 kcmil-900 kcmil	477.0 (18/1) Pelican kcmil-795 (54/7) Condor kcmil	4.00	1/2	3.50	9.63	5.44	1/2	3.00
NNTR22A29A	4 IPS	1/0 AWG-250 kcmil	1/0 (6/1) Raven AWG-4/0 (6/1) Penquin AWG	4.00	1/2	2.75	9.38	5.75	1/2	2.50
NNTR22A32A	4 IPS	250 kcmil-400 kcmil	4/0 (6/1) Penquin AWG-397.5 (18/1) Chickadee kcmil	4.00	1/2	3.00	9.58	5.75	1/2	2.63
NNTR22A36A	4 IPS	350 kcmil-600 kcmil	336.4 (18/1) Merlin kcmil-477.0 (18/1) Pelican kcmil	4.00	1/2	3.25	9.88	5.75	1/2	2.75
NNTR22A42A	4 IPS	600 kcmil-900 kcmil	477.0 (18/1) Pelican kcmil-795 (54/7) Condor kcmil	4.00	1/2	3.50	10.13	5.75	1/2	3.00
NNTR22A45A	4 IPS	900 kcmil-1250 kcmil	715.5 (54/7) Crow kcmil-1113 (54/19) Finch kcmil	4.00	1/2	3.75	10.38	5.75	1/2	3.00
NNTR22A46A	4 IPS	1250 kcmil-1600 kcmil	1113 (54/19) Finch kcmil-1431 (54/19) Plover kcmil	6.00	5/8	4.38	11.25	6.19	5/8	3.75
NNTR22A48A	4 IPS	1500 kcmil-2000 kcmil	1272 (54/19) Pheasant kcmil-1780 (54/19) kcmil	6.00	5/8	4.50	11.38	6.19	5/8	3.88

**TYPE NN2TR
T-CONNECTOR**

For Use On PIPE TO (2)
CABLE TAP

Aluminum alloy T-Connector for tubing run and (2) cable tap. Properly proportioned to permit use on copper-aluminum conductor combinations. Captured hex head bolts permit one-wrench installation.



Material: Aluminum Alloy
Hardware: Aluminum Hardware

Notes :

- PENETROX™ A joint compound is recommended on contact surfaces
- Please contact factory for other sizes, combinations and availability
- One-wrench installation.

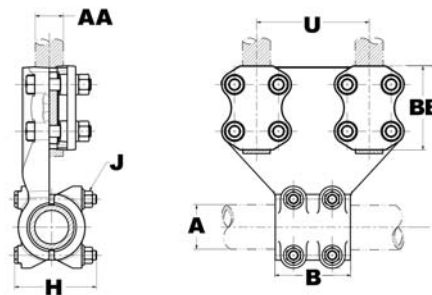

Catalog Number	A - Run Al tube	AA - Tap ACSR Cable	AA - Tap Al Cable	BB	B	J Dia.	U
NN2TR18A46AL6	2 IPS	1113 (54/19) Finch kcmil- 1431 (54/19) Plover kcmil	1250 kcmil- 1600 kcmil	4.50	4.00	1/2	6.00
NN2TR19A42A	2 1/2 IPS	477.0 (24/7) Flicker kcmil- 795 (30/19) Mallard kcmil	600 kcmil- 900 kcmil	3.62	4.00	1/2	3.25
NN2TR19A45A	2 1/2 IPS	715.5 (54/7) Crow kcmil- 1113 (54/19) Finch kcmil	900 kcmil- 1250 kcmil	3.88	4.00	1/2	3.44
NN2TR20A44A	3 IPS	N/A	900 kcmil- 1000 kcmil	3.88	5.00	5/8	3.44
NN2TR22A44A	4 IPS		900 kcmil- 1000 kcmil	3.88	6.00	5/8	3.44
NN2TR22A45A	4 IPS	715.5 (54/7) Crow kcmil- 1113 (54/19) Finch kcmil	900 kcmil- 1250 kcmil	3.88	6.00	5/8	3.44
NN2TR22A48A	4 IPS	1272 (54/19) Pheasant kcmil- 1780 (54/19) kcmil	1500 kcmil- 2000 kcmil	4.62	6.00	5/8	4.19
NN2TR86A45A	6 IPS	715.5 (54/7) Crow kcmil- 1113 (54/19) Finch kcmil	900 kcmil- 1250 kcmil	3.88	6.00	5/8	3.44

**TYPE NBC-A
BOLTED CONNECTOR**

For Use On PIPE TO
CENTERLINE TAP PAD

Aluminum alloy bolted type terminal for joining aluminum tube to copper or aluminum pads. Drilling in pad conforms to NEMA Standards. PENETROX™ joint compound recommended on contact surfaces.



Material: Aluminum Alloy
Hardware: Aluminum Hardware

Notes :

- Properly proportioned to minimize conductor corrosion due to galvanic action. When properly used, this item does not require use of bimetallic plates. Please ask BURNDY® Technical Support for recommendations
- PENETROX™ A joint compound is recommended on contact surfaces
- Please contact factory for other sizes, combinations and availability
- One-wrench installation.

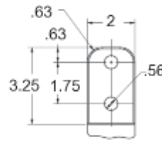
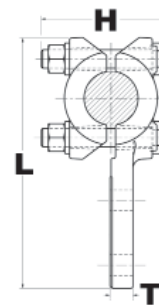
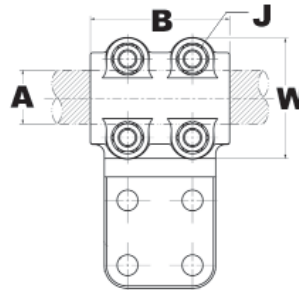

Fig. 1

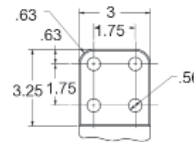

Fig. 2

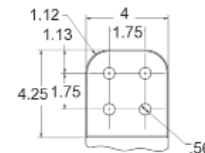

Fig. 3

Catalog Number	Fig. #	Al tube	B	J Dia.	L	H	T
NBC14A2N	1	3/4 IPS	3.25	1/2	6.56	3.50	3/8
NBC15A-2N	1	1 IPS	3.50	1/2	6.81	3.00	3/8
NBC15A34N	2		3.50	1/2	6.81	3.00	3/8
NBC16A2N	1	1 1/4 IPS	3.75	1/2	7.15	3.25	3/8
NBC16A34N	2		3.75	1/2	7.15	3.25	3/8
NBC16A44N	3		3.75	1/2	8.15	3.25	3/8
NBC17A2N	1	1 1/2 IPS	4.00	1/2	7.39	3.50	3/8
NBC17A34N	2		4.00	1/2	7.39	3.50	3/8
NBC17A44N	3		4.00	1/2	8.39	3.50	3/8
NBC18A2N	1	2 IPS	4.25	5/8	8.25	4.00	3/8
NBC18A34N	2		4.25	5/8	8.25	4.00	3/8
NBC18A-44N	3		4.25	5/8	9.25	4.00	3/8
NBC19A34N	2	2 1/2 IPS	4.50	5/8	8.75	4.50	1/2
NBC19A44N	3		4.50	5/8	9.75	4.50	1/2

**TYPE NBC-A
BOLTED CONNECTOR**
(Continued)

For Use On PIPE TO
CENTERLINE TAP PAD



Catalog Number	Fig. #	Al tube	B	J Dia.	L	H	T
NBC20A2N	1	3 IPS	5.00	5/8	9.37	4.50	1/2
NBC20A34N	2		5.00	5/8	9.37	4.50	1/2
NBC20A-44N	3		5.00	5/8	10.37	4.50	1/2
NBC21A44N	3	3 1/2 IPS	5.50	5/8	10.89	5.00	5/8
NBC22A2N	1	4 IPS	6.00	5/8	10.38	5.50	5/8
NBC22A34N	2		6.00	5/8	10.37	5.50	5/8
NBC22A44N	3		6.00	5/8	11.37	5.50	5/8
NBC24A2N	1	5 IPS	7.00	5/8	12.45	6.00	5/8
NBC24A34N	2		7.00	5/8	12.45	6.00	5/8
NBC24A44N	3		7.00	5/8	13.45	6.00	5/8
NBC86A44N	3	6 IPS	8.00	5/8	13.51	7.25	3/4

**TYPE NBCR
BOLTED TERMINAL**

For Use On CABLE TO FLAT
TAP PAD

Aluminum alloy terminal for joining a wide range of aluminum cables to copper or aluminum tap pad. Pad drilling conforms to NEMA standards. One-wrench installation.



Material: Aluminum Alloy
Hardware: Aluminum Hardware

Notes :

- PENETROX™ A joint compound is recommended on contact surfaces
- Please contact factory for other sizes, combinations and availability
- One-wrench installation.

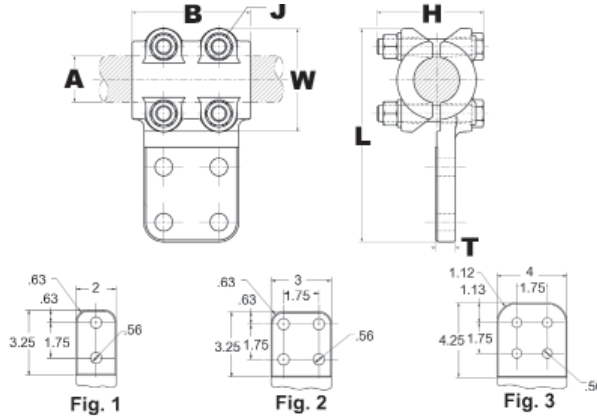

Catalog Number	Fig. #	Aluminum Stranded	Aluminum ACSR	B	J Dia.	L	W	H
NBCR29A2N	1	1/0 AWG-250 kcmil	1 (6/1) Robin AWG-	2.75	1/2	6.17	2.42	2.25
NBCR29A34N	2		4/0 (6/1) Penquin AWG	2.75	1/2	6.17	2.42	2.25
NBCR32A2N	1	250 kcmil-400 kcmil	4/0 (6/1) Penquin AWG-397.5 (18/1) Chickadee kcmil	3.00	1/2	6.33	2.58	2.25
NBCR32A34N	2		4/0 (6/1) Penquin AWG-397.5 (24/7) Brant kcmil	2.75	1/2	6.33	2.58	2.25
NBCR32A44N	3		4/0 (6/1) Penquin AWG-397.5 (18/1) Chickadee kcmil	3.00	1/2	7.33	2.58	2.25
NBCR36A2N	1	350 kcmil-600 kcmil	336.4 (18/1) Merlin kcmil-477.0 (18/1) Pelican kcmil	3.25	1/2	6.43	2.68	2.25
NBCR36A34N	2			3.25	1/2	6.50	2.68	2.25
NBCR36A44N	3			3.25	1/2	7.48	2.68	2.25
NBCR42A2N	1	600 kcmil-900 kcmil	477.0 (18/1) Pelican kcmil-795 (54/7) Condor kcmil	3.50	1/2	6.69	2.94	2.50
NBCR42A34N	2			3.50	1/2	6.75	2.94	2.50
NBCR42A44N	3			3.50	1/2	7.68	2.94	2.50
NBCR45A2N	1	900 kcmil-1250 kcmil	715.5 (54/7) Crow kcmil-1113 (54/19) Finch kcmil	3.75	1/2	6.89	3.14	2.50
NBCR45A32N	2		715.5 (24/7) Stilt kcmil-1113 (54/19) Finch kcmil	3.75	1/2	6.89	3.14	2.50
NBCR45A34N	2	600 kcmil-900 kcmil	715.5 (54/7) Crow kcmil-1113 (54/19) Finch kcmil	3.75	1/2	6.89	3.14	2.50
NBCR45A44N	3			3.75	1/2	7.89	3.14	2.50

TYPE NBCR
BOLTED TERMINAL
 (Continued)

For Use On CABLE TO FLAT
 TAP PAD



Catalog Number	Fig. #	Aluminum Stranded	Aluminum ACSR	B	J Dia.	L	W	H
NBCR46A34N	2	1250 kcmil- 1600 kcmil	1113 (54/19) Finch kcmil- 1431 (54/19) Plover kcmil	4.38	5/8	7.41	3.66	3.00
NBCR46A44N	3			4.38				
NBCR486A44N	3	2000 kcmil- 2500 kcmil	N/A	4.62	5/8	8.74	4.07	3.00
NBCR48A2N	1	1500 kcmil- 2000 kcmil	1272 (54/19) Pheasant kcmil- 1780 (54/19) kcmil	4.50	5/8	7.57	3.82	3.00
NBCR48A34N	2			4.50				
NBCR48A44N	3			4.50				
NBCR495A44N	3	2500 kcmil- 3500 kcmil	N/A	5.25	5/8	9.14	4.40	4.00

**TYPE N2BCR
BOLTED TERMINAL**

For Use On (2) AL CABLE TO
FLAT TAP PAD

Aluminum alloy terminal for joining a wide range of (2) aluminum cables to copper or aluminum tap pad. Drilling in pad conforms to NEMA standards. One-wrench installation.

Material: Aluminum Alloy
Hardware: Aluminum Hardware

Notes :

- PENETROX™ A joint compound is recommended on contact surfaces
- Please contact factory for other sizes, combinations and availability
- One-wrench installation.

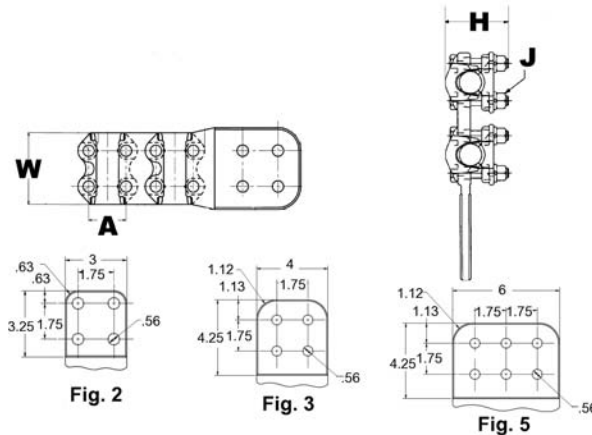

Catalog Number	Fig. #	Aluminum Stranded	Aluminum ACSR	J Dia.	H	W
N2BCR36A44N	3	350 kcmil- 600 kcmil	336.4 (18/1) Merlin kcmil- 477 (30/7) Hen kcmil	1/2	2.25	2.64
N2BCR42A34N	2	600 kcmil- 900 kcmil	477.0 (18/1) Pelican kcmil- 795 (30/19) Mallard kcmil	1/2	3.11	3.00
N2BCR42A44N	3			1/2	3.11	3.00
N2BCR45A44N	3	900 kcmil- 1250 kcmil	715.5 (54/7) Crow kcmil- 1113 (54/19) Finch kcmil	1/2	2.50	3.14
N2BCR48A2N	1	1500 kcmil- 2000 kcmil	1272 (54/19) Pheasant kcmil- 1780 (84/19) Chukar kcmil	5/8	3.00	3.82
N2BCR48A44N	3			5/8	3.00	3.88

**TYPE XTA
EXPANSION T
CONNECTOR**

For Use On TUBE TO TUBE

Aluminium alloy expansion
T-Connector for Bus to Bus
connection.

Material: Aluminum Alloy
Hardware: Aluminum Hardware

Notes :

- PENETROX™ A joint compound is recommended on contact surfaces
- Please contact factory for other sizes, combinations and availability
- One-wrench installation.

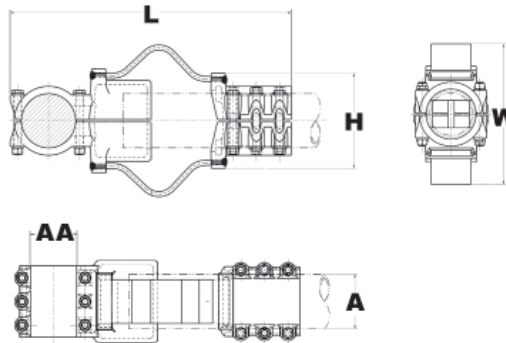

Catalog Number	A - Run tube Schd 40	L	H	W
XT15A15A	1 IPS	14.00	3.75	3.06
XT17A17A	1 1/2 IPS	15.88	4.50	3.63
XT18A18A	2 IPS	16.56	5.94	4.62
XT20A20A	3 IPS	21.88	6.81	5.63
XT22A22A	4 IPS	26.50	8.19	6.63
XT23A23A	4 1/2 IPS	26.06	9.60	7.50

**TYPE SNNT
T-CONNECTOR**

For Use On PIPE RUN TO PIPE
OR CABLE TAP

Streamlined aluminum alloy
T-Connector for joining a range of
aluminum pipes to aluminum pipe or
cable tap.

**EHV RATED: SELF-SHIELDING UP
TO 550kV**

Material: Aluminum Alloy
Hardware: Aluminum Hardware

Notes :

- PENETROX™ A joint compound is recommended on contact surfaces
- Please contact factory for other sizes, combinations and availability
- One-wrench installation.

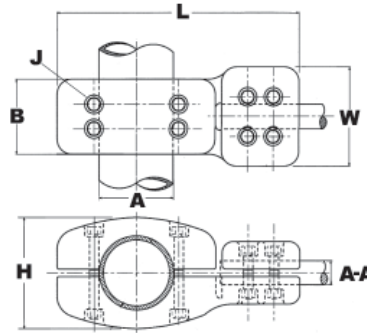

Catalog Number	A - Run tube	AA - Tap tube	AA - Al Cable Tap	B	J Dia.	L	W	H
SNNT20A20A	3 IPS	3 IPS	N/A	5.00	5/8	12.87	7.56	4.75
SNNT22A20A	4 IPS	3 IPS	N/A	6.00	5/8	13.87	7.56	5.75
SNNT22A22A		4 IPS	N/A	6.00	5/8	14.94	8.56	5.75
SNNT24A24A	5 IPS	5 IPS	N/A	7.00	5/8	17.06	9.68	6.94
SNNT24A486A		N/A	2300 kcmil- 2500 kcmil	6.00	5/8	15.31	5.64	6.94
SNNT86A48AGS	6 IPS	N/A	2000 kcmil	8.00	5/8	16.73	11.25	8.62

**TYPE SNNT
T-CONNECTOR**

For Use On CABLE TO CABLE

Aluminum alloy T-Connector for joining a range of aluminum or ACSR cable on run and tap.

EHV RATED: SELF-SHIELDING UP TO 550kV

Material: Aluminum Alloy
Hardware: Aluminum Hardware

Notes :

- PENETROX™ A joint compound is recommended on contact surfaces
- Please contact factory for other sizes, combinations and availability
- One-wrench installation.

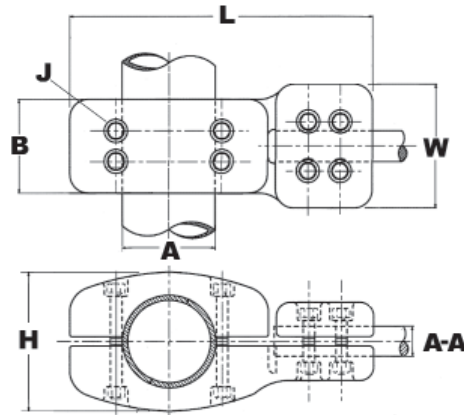

Catalog Number	A - Run Al Cable	A - Run ACSR Cable	AA - Tap Al Cable	AA - Tap ACSR Cable	B	J Dia.	L	H	W
SNNT44A44AS3	900 kcmil-1000 kcmil	795 (54/7) Condor kcmil-874.5 (54/7) Crane kcmil	900 kcmil-1000 kcmil	795 (54/7) Condor kcmil-874.5 (54/7) Crane kcmil	6.75	1/2	10.09	3.24	3.03
SNNT45A46AS3	1192 kcmil-1351 kcmil	1033.5 (45/7) Ortolan kcmil-1192.5 (54/19) Grackle kcmil	1400 kcmil-1600 kcmil	1272 (54/19) Pheasant kcmil-1510.5 (45/7) Nuthatch kcmil	3.25	1/2	8.69	3.84	4.88
SNNT45A47AS3	1033 kcmil	N/A	1750 kcmil	N/A	6.75	1/2	10.56	3.62	3.50
SNNT46A486AS3	1590 kcmil		2500 kcmil	N/A	4.88	1/2	8.82	3.84	3.62
SNNT47A47AS3	1750 kcmil		1750 kcmil	N/A	6.75	1/2	10.56	3.62	3.50

**TYPE SNNT
T-CONNECTOR**

For Use On CABLE TO CABLE

Aluminum alloy T-Connector for joining a range of aluminum cable on run and tap.

EHV RATED: SELF-SHIELDING UP TO 550kV

Material: Aluminum Alloy
Hardware: Aluminum Hardware

Notes :

- PENETROX™ A joint compound is recommended on contact surfaces
- Please contact factory for other sizes, combinations and availability
- One-wrench installation.

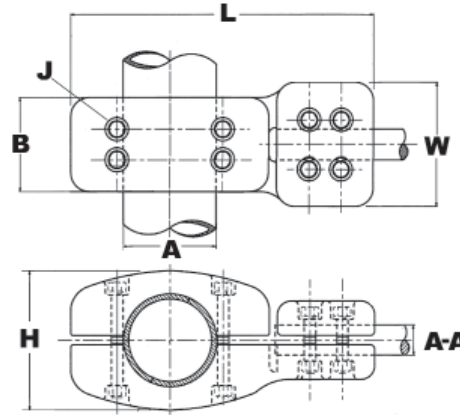

Catalog Number	A - Run Al Cable	AA - Tap Al Cable	AA - Tap ACSR Cable	B	J Dia.	L	H	W
SNNT496A445AS7	4000 kcmil	N/A	954 (45/7) Rail kcmil	8.00	5/8	15.75	4.56	7.44
SNNT496A47AS7		1800 kcmil	N/A	8.00	5/8	15.75	4.53	6.88
SNNT496A496AS7		4000 kcmil	N/A	8.00	5/8	15.75	4.62	7.44
SNNT496A53RS7		N/A	1351.5 (54/19) Martin kcmil	8.00	5/8	15.75	4.53	6.88

**TYPE SNNTV
T-CONNECTOR**

For Use On TUBE TO TUBE
(VARIABLE ANGLE)

Aluminum alloy T-Connector for joining aluminum pipe to pipe at an angle varying between 0° and 60°.

EHV RATED: SELF-SHIELDING UP TO 550kV

Material: Aluminum Alloy
Hardware: Aluminum Hardware

Notes :

- PENETROX™ A joint compound is recommended on contact surfaces
- Please contact factory for other sizes, combinations and availability
- One-wrench installation.

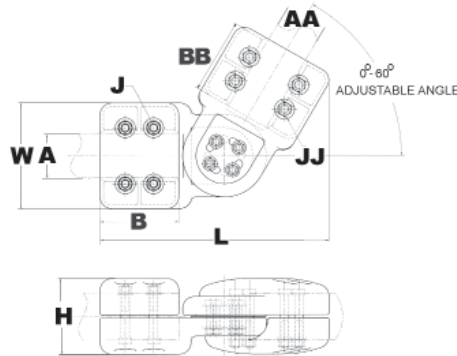

Catalog Number	A - Run tube	AA - Tap tube	B	J Dia.	JJ Dia.	BB	L	H	W
SNNTV20A20AGS	3 IPS	3 IPS	5.88	5/8	5/8	5.88	18.60	14.05	8.00
SNNTV23A23AS7GS	4 1/2 IPS	4 1/2 IPS	8.00	5/8	5/8	8.00	24.88	18.46	10.25

**TYPE SNBC
TERMINAL**

For Use On PIPE OR CABLE
TO TAP PAD

Aluminum alloy terminal for joining a wide range of cables to aluminum pads. Properly proportioned to minimize conductor corrosion due to galvanic action. Drilling in pads conforms to NEMA standards. One wrench installation.

EHV RATED: SELF-SHIELDING UP TO 550kV

Material: Aluminum Alloy
Hardware: Aluminum Hardware

Notes :

- PENETROX™ A joint compound is recommended on contact surfaces
- Please contact factory for other sizes, combinations and availability
- One-wrench installation.

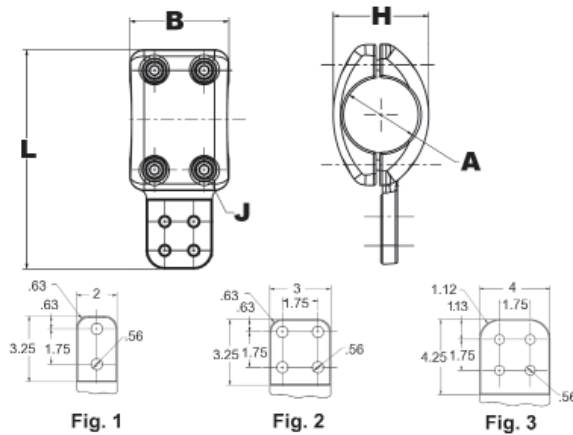

Catalog Number	Fig. #	Aluminum Stranded	B	J Dia.	L	H
SNBC47A44NS3	3	1800 kcmil	6.75	1/2	8.00	3.74

**TYPE SNBC
TERMINAL**

For Use On PIPE OR CABLE
TO TAP PAD

Aluminum alloy terminal for joining a wide range of cable or pipe to aluminum tap pads. Properly proportioned to minimize conductor corrosion due to galvanic action. Drilling in pads conforms to NEMA standards. One wrench installation. Pad requires STS shielding caps for EHV.

EHV RATED: SELF-SHIELDING UP TO 550kV(USE SHIELDING CAPS)

Material: Aluminum Alloy
Hardware: Aluminum Hardware

Notes :

- PENETROX™ A joint compound is recommended on contact surfaces
- Please contact factory for other sizes, combinations and availability
- One-wrench installation.

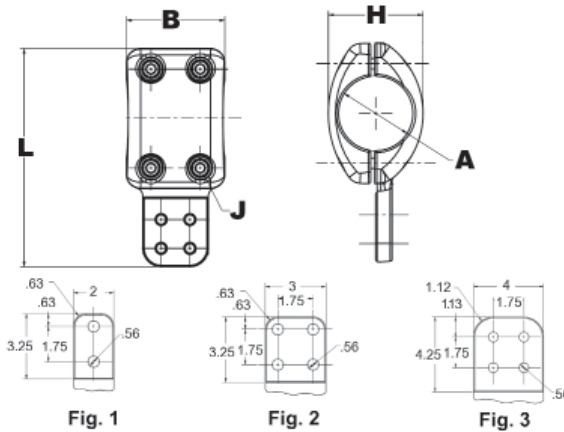

Catalog Number	Fig. #	Aluminum Stranded	Aluminum ACSR	Aluminum tube	B	J Dia.	L
SNBC22A44NSTS	3	N/A	N/A	4 IPS	6.00	5/8	13.31
SNBC22A4N	3			4 IPS	6.00	5/8	10.38
SNBC45A44N	3	1192 kcmil- 1272 kcmil	1033.5 (45/7) Ortolan kcmil- 1192.5 (54/19) Grackle kcmil	N/A	4.00	1/2	7.29
SNBC486A44N	3	2300 kcmil- 2500 kcmil	2156 (64/119) kcmil- 2167 (72/7) Kiwi kcmil	N/A	5.25	5/8	7.70
SNBC486A4N	3			N/A	5.25	5/8	6.45
SNBC496A44NS7HQ	3	4000 kcmil	N/A	N/A	8.00	5/8	12.19
SNBC86A44N	3	N/A		6 IPS	8.00	5/8	15.50
SNBC86A44NS7SS	3			6 IPS	8.00	5/8	17.00

**TYPE SNBC
TERMINAL**

For Use On PIPE OR CABLE
TO TAP PAD



Aluminum alloy terminal for joining a wide range of cable or pipe to aluminum tap pads. Properly proportioned to minimize conductor corrosion due to galvanic action. Drilling in pads conforms to NEMA standards. One wrench installation. Pad requires STS shielding caps for EHV.

EHV RATED: SELF-SHIELDING UP TO 550kV(USE SHIELDING CAPS)

Material: Aluminum Alloy
Hardware: Aluminum Hardware

Notes :

- PENETROX™ A joint compound is recommended on contact surfaces
- Please contact factory for other sizes, combinations and availability
- One-wrench installation.

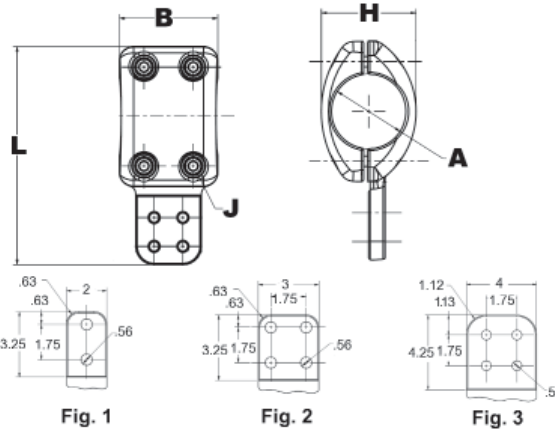

Catalog Number	Fig. #	A-Aluminum Stranded	A-Aluminum tube	B	J Dia.	L	H
SNBC496A44NS7HQ	3	4000 kcmil	N/A	8.00	5/8	12.19	4.62
SNBC86A44NS7SS	3	N/A	6 IPS	8.00	5/8	17.00	8.70

**TYPE SN2B
TERMINAL**

For Use On CABLE TO FLAT

Streamlined aluminum alloy terminal for joining a wide range of cable to aluminum pads. Properly proportioned to minimize conductor corrosion due to galvanic action. Drilling in pads conforms to NEMA standards. One wrench installation. Pad requires STS shielding caps for EHV.

EHV RATED: SELF-SHIELDING UP TO 550kV

Material: Aluminum Alloy
Hardware: Aluminum Hardware

Notes :

- PENETROX™ A joint compound is recommended on contact surfaces

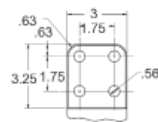
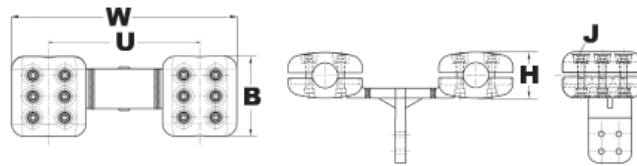

Fig. 2

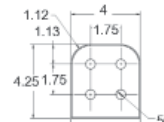

Fig. 3

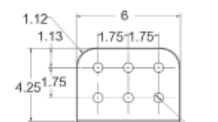
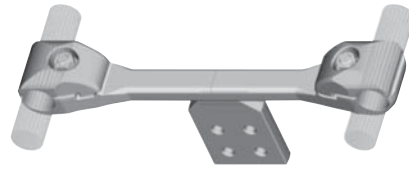

Fig. 5

Catalog Number	Fig. #	Aluminum Stranded	J Dia.	U	H	B	W
SN2B496A44N90RS7	3	4000 kcmil	5/8	15.12	11.12	8.00	22.56

**TYPE S2GBPA
SPACER TERMINAL**

For Use On (2) CABLES TO
TAP PAD



Streamlined rigid spacer for large range of cables with tap pad. Particularly appropriate for 8"+ spacing. 1 bolt per clamping module version. Pad requires STS shielding caps for EHV.

EHV RATED: SELF-SHIELDING UP TO 550kV

Material: Aluminum Alloy
Hardware: Aluminum Hardware

Notes :

- Properly proportioned to minimize conductor corrosion due to galvanic action. When properly used, this item does not require use of bimetallic plates. Please ask BURNDY® Technical Support for recommendations
- PENETROX™ A joint compound is recommended on contact surfaces
- Please contact factory for other sizes, combinations and availability
- One-wrench installation.

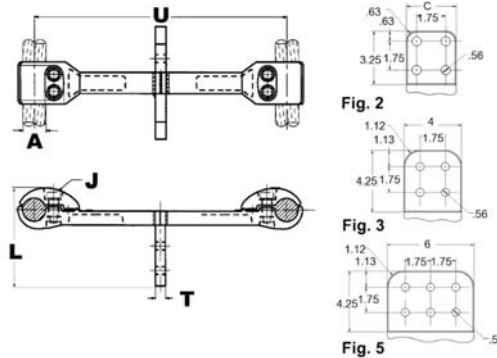

Catalog Number	Aluminum Stranded	Aluminum ACSR	T	J Dia.	U	L
S2GBPA36A8	350 kcmil-600 kcmil	336.4 (30/7) Oriole kcmil- 477 (30/7) Hen kcmil	.81	5/8	8	10.04
S2GBPA445A	1033 kcmil-1113 kcmil	954 (45/7) Rail kcmil- 1033.5 (54/7) Curlew kcmil		5/8	18	20.30
S2GBPA44A	954 kcmil	795 (54/7) Condor kcmil- 874.5 (54/7) Crane kcmil	.38	5/8	18	19.68
S2GBPA44A12	954 kcmil	795 (54/7) Condor kcmil	.81	5/8	12	12.00
S2GBPA44A8	954 kcmil	795 (54/7) Condor kcmil- 874.5 (54/7) Crane kcmil		5/8	8	9.74
S2GBPA45A	1192 kcmil-1272 kcmil	1033.5 (45/7) Ortolan kcmil- 1192.5 (45/7) Bunting kcmil	.50	5/8	18	20.26
S2GBPA45A12	1192 kcmil-1272 kcmil	1033.5 (45/7) Ortolan kcmil- 1192.5 (54/19) Grackle kcmil		5/8	12	14.32
S2GBPA46A12	1590 kcmil-1600 kcmil	1272 (54/19) Pheasant kcmil- 1431 (54/19) Plover kcmil	0.38	5/8	12	12.00
S2GBPA46A8	1590 kcmil		5/8	8	10.30	
S2GBPA486A12	2300 kcmil-2500 kcmil	2156 (84/19) Bluebird kcmil- 2167 (72/7) Kiwi kcmil	.81	5/8	12	14.56
S2GBPA48A	1750 kcmil-2000 kcmil			5/8	18	20.30
S2GBPA48A10	1750 kcmil-2000 kcmil	1590 (45/7) Lapwing kcmil- 1780 (84/19) Chukar kcmil	0.81	5/8	10	12.30
S2GBPA48A12	1750 kcmil-2000 kcmil			5/8	12	14.30
S2GBPA48A8	1750 kcmil-2000 kcmil			5/8	8	10.30

**TYPE S2GBPA-B2
SPACER**

For Use On (2) CABLES TO
TAP PAD



Streamlined rigid spacer for large range of cables with tap pad. Particularly appropriate for 8"+ spacing. 2 bolts per clamping module provides additional clamping strength. Pad requires STS shielding caps for EHV.

EHV RATED: SELF-SHIELDING UP TO 550kV

Material: Aluminum Alloy
Hardware: Aluminum Hardware

Notes :

- Properly proportioned to minimize conductor corrosion due to galvanic action. When properly used, this item does not require use of bimetallic plates. Please ask BURNDY® Technical Support for recommendations
- PENETROX™ A joint compound is recommended on contact surfaces
- Please contact factory for other sizes, combinations and availability
- One-wrench installation

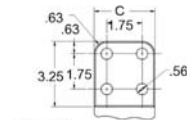
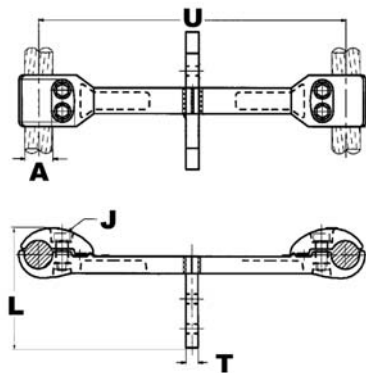

Fig. 2

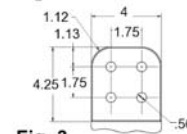

Fig. 3

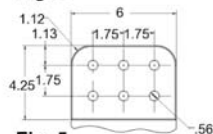
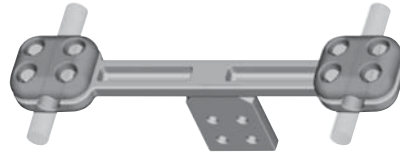

Fig. 5

Catalog Number	Aluminum Stranded	Aluminum ACSR	J Dia.	U	L	T	C
S2GBPA44A12B2	954 kcmil	N/A	5/8	12	13.68	0.81	4.00
S2GBPA45A12B2	1192 kcmil- 1272 kcmil	1033.5 (54/7) Curlew kcmil- 1113 (54/19) Finch kcmil		12	13.84	0.81	4.00
S2GBPA45AB2	1192 kcmil- 1272 kcmil			18	20.32	.50	4.00
S2GBPA486A12B2	2300 kcmil- 2500 kcmil	2156 (64/119) kcmil- 2312 (76/19) Thrasher kcmil		12	14.52	1.00	4.00
S2GBPA48A12B2	1750 kcmil- 2000 kcmil	2156 (84/19) Bluebird kcmil- 2312 (76/19) Thrasher kcmil		12	14.30	0.81	4.00

**TYPE S2GBPA-B4
SPACER**

For Use On (2) CABLES TO
TAP PAD



Streamlined rigid spacer for large range of cables with tap pad. Particularly appropriate for 8"+ spacing. Version with 4 bolts per clamping module - 2 on each side - provide ideal clamping of cable. Pad requires STS shielding caps for EHV. **EHV RATED: SELF-SHIELDING UP TO 550kV**

Material: Aluminum Alloy
Hardware: Aluminum Hardware

Notes :

- Properly proportioned to minimize conductor corrosion due to galvanic action. When properly used, this item does not require use of bimetallic plates. Please ask BURNDY® Technical Support for recommendations
- PENETROX™ A joint compound is recommended on contact surfaces
- Please contact factory for other sizes, combinations and availability
- One-wrench installation.

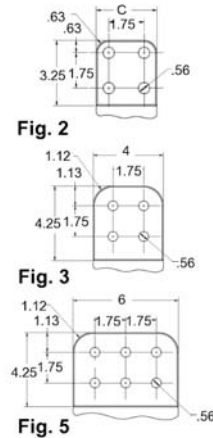
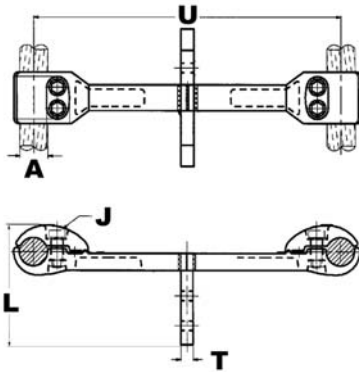

Catalog Number	Aluminum Stranded	Aluminum ACSR	T	J Dia.	U	L	C
S2GBPA41A12B4	795 kcmil-874 kcmil	795 (54/7) Condor kcmil	.44	5/8	12.00	13.42	4.00
S2GBPA445A12B4	1033 kcmil-1113 kcmil	954 (45/7) Rail kcmil- 1033.5 (54/7) Curlew kcmil		5/8	12.00	16.62	4.00
S2GBPA445AB4	1033 kcmil-1113 kcmil	954 (45/7) Rail kcmil- 1033.5 (45/7) Ortolan kcmil		5/8	18	22.60	4.00
S2GBPA44A12B4	954 kcmil	795 (26/7) Drake kcmil- 874.5 (54/7) Crane kcmil	.38	5/8	12.00	13.5	4.00
S2GBPA44AB4	954 kcmil	795 (30/19) Mallard kcmil- 874.5 (54/7) Crane kcmil		5/8	18	19.5	4.00
S2GBPA45A12B4	1192 kcmil-1272 kcmil	1033.5 (45/7) Ortolan kcmil- 1192.5 (54/19) Grackle kcmil	.44	5/8	12.00	14.32	4.00
S2GBPA46A12B4	1590 kcmil	1272 (54/19) Pheasant kcmil- 1431 (54/19) Plover kcmil	.62	5/8	12.00	13.82	4.00
S2GBPA483A12B4	2000 kcmil-2250 kcmil	2034.5 (72/7) Mockingbird kcmil- 2167 (72/7) Kiwi kcmil	.88	5/8	12.00	14.13	4.00
S2GBPA483AB4	2000 kcmil-2250 kcmil	1780 (84/19) Chukar kcmil- 2167 (72/7) Kiwi kcmil		5/8	18	20.13	4.00
S2GBPA486A12B4	2300 kcmil-2500 kcmil	2156 (64/119) kcmil- 2167 (72/7) Kiwi kcmil	1.00	5/8	12.00	14.32	4.00
S2GBPA486AB4	2300 kcmil-2500 kcmil			5/8	18.00	20.30	4.00
S2GBPA48A12B4	1750 kcmil-2000 kcmil	1590 (54/19) Falcon kcmil- 1780 (54/19) kcmil	.81	5/8	12.00	14.32	4.00

Table of Contents - Aluminum A-Frames



Type AT-A A Frame

A-109



Type NNT-75 Cable to Tap Pad

A-110



Type SAT Pipe or Cable

A-111



Type SNNT Pipe to Pipe

A-112



TYPE AT-A
AL A FRAME

For Use On ALUMINUM PIPE A FRAME

Aluminum alloy T-Connector for tubing run to tubing (2) taps forming a 20 or 30 degree A frame. Captured hex head bolts permit one-wrench installation.



Material: Aluminum Alloy
Hardware: Aluminum Hardware

Notes :

- PENETROX™ A joint compound is recommended on contact surfaces
- Please contact factory for other sizes, combinations and availability
- One wrench installation.

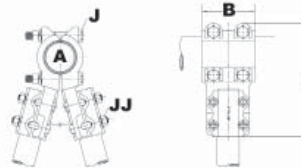

Catalog Number	A - Run tube	AA - Tap tube	B	J Dia.	JJ Dia.	L
AT16A15A30	1 1/4 IPS	1 IPS	3.75	1/2	1/2	7.29
AT17A15A30	1 1/2 IPS		4.00	1/2	1/2	7.64
AT18A16A20	2 IPS	1 1/4 IPS	4.00	1/2	1/2	8.81
AT18A16A30	2 IPS		4.00	1/2	1/2	8.43
AT19A17A30	2 1/2 IPS	1 1/2 IPS	4.00	1/2	1/2	9.24
AT19A18A20	2 1/2 IPS	2 IPS	4.50	5/8	5/8	9.97
AT19A18A30	2 1/2 IPS		4.50	5/8	5/8	9.66
AT19A19A30	2 1/2 IPS	2 1/2 IPS	5.00	5/8	5/8	10.38
AT20A17A20	3 IPS	1 1/2 IPS	4.00	1/2	1/2	10.38
AT20A17A30	3 IPS		5.00	5/8	5/8	10.38
AT20A18A20	3 IPS	2 IPS	5.00	5/8	5/8	10.69
AT20A18A30	3 IPS		5.00	5/8	5/8	10.56
AT21A17A30	3 1/2 IPS	1 1/2 IPS	4.00	1/2	1/2	11.07
AT21A18A20	3 1/2 IPS	2 IPS	5.50	5/8	5/8	11.19
AT21A18A30	3 1/2 IPS		5.50	5/8	5/8	11.00
AT21A19A30	3 1/2 IPS	2 1/2 IPS	5.50	5/8	5/8	11.32
AT22A17A30	4 IPS	1 1/2 IPS	4.00	1/2	1/2	11.23
AT22A18A20	4 IPS	2 IPS	6.00	5/8	5/8	11.31
AT22A18A30	4 IPS		6.00	5/8	5/8	11.77
AT22A19A20	4 IPS	2 1/2 IPS	6.00	5/8	5/8	11.88
AT22A19A30	4 IPS		6.00	5/8	5/8	11.87
AT22A20A30	4 IPS	3 IPS	6.00	5/8	5/8	12.42
AT24A19A20	5 IPS	2 1/2 IPS	7.00	5/8	5/8	13.44
AT24A19A30	5 IPS		6.00	5/8	5/8	13.32
AT24A20A20GS	5 IPS	3 IPS	6.00	5/8	5/8	13.62
AT86A20A30	6 IPS		6.00	5/8	5/8	14.74

**TYPE NNT-75
T-CONNECTOR**

For Use On TUBE TO TUBE

Aluminum alloy T-Connector for tubing run and tap. Properly proportioned to permit use on copper-aluminum conductor combinations. Captured hex head bolts permit one-wrench installation.



Material: Aluminum Alloy
Hardware: Aluminum Hardware

Notes :

- PENETROX™ A joint compound is recommended on contact surfaces
- Please contact factory for other sizes, combinations and availability
- One-wrench installation.

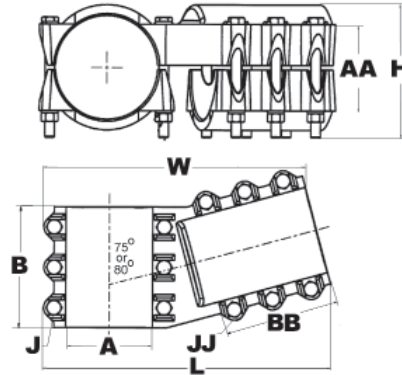

Catalog Number	A - Run tube	AA - Tap tube	Angle	B	J Dia.	JJ Dia.	BB	L	H	W
NNT14A14A75	3/4 IPS	3/4 IPS	75°	3.25	1/2	1/2	3.25	6.42	3.00	3.25
NNT16A14A75	1 1/4 IPS		75°	3.75	1/2	1/2	3.25	7.06	3.25	3.25
NNT16A15A75	1 1/4 IPS	1 IPS	75°	3.75	1/2	1/2	3.50	7.41	3.25	3.5
NNT17A15A75	1 1/2 IPS		75°	4.00	1/2	1/2	3.50	7.65	3.50	3.06
NNT18A15A75	2 IPS		75°	4.00	1/2	1/2	3.50	8.13	4.38	3.06
NNT18A16A75	2 IPS	1 1/4 IPS	75°	4.00	1/2	1/2	3.75	8.50	4.00	3.75
NNT18A18A75	2 IPS	2 IPS	75°	4.25	1/2	5/8	4.25	9.00	4.40	4.50
NNT19A17A75	2 1/2 IPS	1 1/2 IPS	75°	4.00	1/2	1/2	4.00	9.34	4.39	3.62
NNT19A18A75	2 1/2 IPS	2 IPS	75°	4.50	5/8	1/2	4.25	10.12	4.50	4.25
NNT19A19A75	2 1/2 IPS	2 1/2 IPS	75°	4.50	5/8	5/8	4.50	9.00	4.94	5.00
NNT20A17A75	3 IPS	1 1/2 IPS	75°	4.00	1/2	1/2	4.00	9.19	5.00	3.69
NNT20A17A80	3 IPS		80°	4.00	1/2	1/2	4.00	9.93	4.69	4.00
NNT21A17A75	3 1/2 IPS		75°	4.00	1/2	1/2	4.00	10.46	5.00	4.00
NNT21A18A75	3 1/2 IPS	2 IPS	75°	5.50	5/8	5/8	4.25	11.27	5.56	4.50
NNT21A18A80	3 1/2 IPS		80°	5.50	5/8	5/8	4.25	11.16	5.56	4.50
NNT21A19A75	3 1/2 IPS	2 1/2 IPS	75°	5.50	5/8	5/8	4.50	11.74	5.00	4.50
NNT22A17A75	4 IPS	1 1/2 IPS	75°	4.00	1/2	1/2	4.00	10.96	5.00	4.00
NNT22A18A80	4 IPS	2 IPS	80°	6.00	5/8	5/8	4.25	11.65	6.19	4.50
NNT22A19A75	4 IPS	2 1/2 IPS	75°	6.00	5/8	5/8	4.50	11.62	5.50	5.00
NNT22A19A80	4 IPS		80°	6.00	5/8	5/8	4.50	12.04	6.19	5.00
NNT24A19A75	5 IPS		75°	6.00	5/8	5/8	4.50	13.30	6.00	6.00
NNT24A21A75	5 IPS	3 1/2 IPS	75°	6.00	5/8	5/8	5.50	6.06	14.18	3.83
NNT86A20A75	6 IPS	3 IPS	75°	6.00	5/8	5/8	5.00	15.08	7.25	5.00

**TYPE SAT
AL T CONNECTOR**

For Use On PIPE TO (2) PIPE
'A' SHAPE

Aluminum alloy T-Connector for joining
a range of aluminum or ACSR cable
on run and tap.

**EHV RATED: SELF-SHIELDING UP
TO 550 kV**



Material: Aluminum Alloy
Hardware: Aluminum Hardware

Notes :

- PENETROX™ A joint compound is recommended on contact surfaces
- Contact factory for other sizes, combinations and availability.

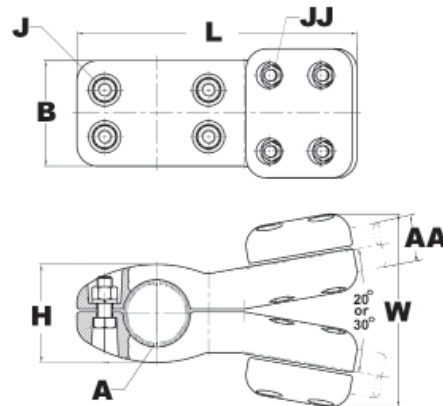

Catalog Number	A - Run Pipe	AA - Tap Pipe	B	J Dia.	JJ Dia.	L	H	W
SAT2419A30345	5 IPS	2 1/2 IPS	5.38	5/8	5/8	14.57	13.51	7.48

**TYPE SNNT
T-CONNECTOR**

For Use On TUBE TO TUBE

Aluminum alloy T-Connector for joining a range of aluminum or ACSR cable on run and tap.

EHV RATED: SELF-SHIELDING UP TO 550 kV

Material: Aluminum Alloy
Hardware: Aluminum Hardware

Notes :

- PENETROX™ A joint compound is recommended on contact surfaces
- Scratch brush connector contact surface, dry then apply an oxide inhibitor. PENETROX™ A can be purchased from BURNDY® in cans or plastic squeeze bottles.

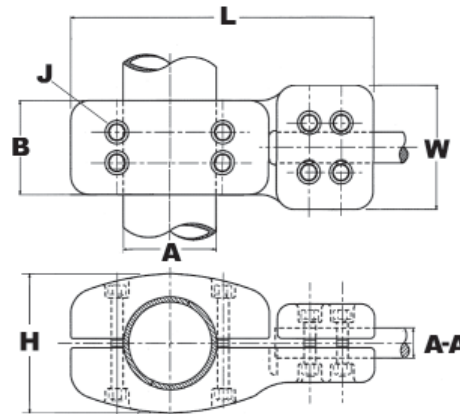



Catalog Number	A - Run tube	AA - Tap tube	B	J Dia.	L	H	W
SNNT86A20A80GS	6 IPS	3 IPS	6.00	5/8	18.56	8.00	11.25

Table of Contents - Aluminum Bolted Stud Connectors

	Type FD-A Stud to Pad	A-115
	Type ND-A-T Stud to Pipe	A-116
	Type NDR-AT Stud to Cable	A-117
	Type NDR-AR Stud to Cable (Flag Position)	A-119
	Type N2DR-AT Stud to 2 Cables	A-120
	Type N2DR-AR Stud to 2 Cables (Flag Position)	A-121
	Type XD-AT Expansion Stud to Pipe	A-122
	Type XD-AR Expansion Stud to Pipe (Flag Position)	A-123
	Type SFD Stud to Pad	A-124
	Type SND-AR Stud to Cable (Flag Position)	A-125
	Type SND-AT Stud to Cable	A-126
	Type SN2D-AR-S7 Stud to 2 Cables	A-127
	Type SN2D-ARS3 Stud to 2 Cables	A-128
	Type SN2D-AT-S3	A-129



Table of Contents - Aluminum Bolted Stud Connectors (continued)

	Type SN2D-AT-S7 Stud to 2 Cables	A-130
	Type SNN2D Stud to 2 Cables	A-131
	Type SXD-T Expansion Stud to Pipe	A-132

TYPE FD-A STUD CONNECTOR

For Use On STUD TO PAD

Aluminum alloy stud connector for joining equipment bushings to conductor terminals.

Material: Aluminum Alloy
Hardware: Aluminum Hardware

Notes :

- Properly proportioned to minimize conductor corrosion due to galvanic action. When properly used, this item does not require use of bimetallic plates. Please ask BURNDY® Technical Support for recommendations
- PENETROX™ A joint compound is recommended on contact surfaces
- Pad is finished on both sides
- Amperage rating given is for indoor conditions
- Please contact factory for other sizes, combinations and availability.

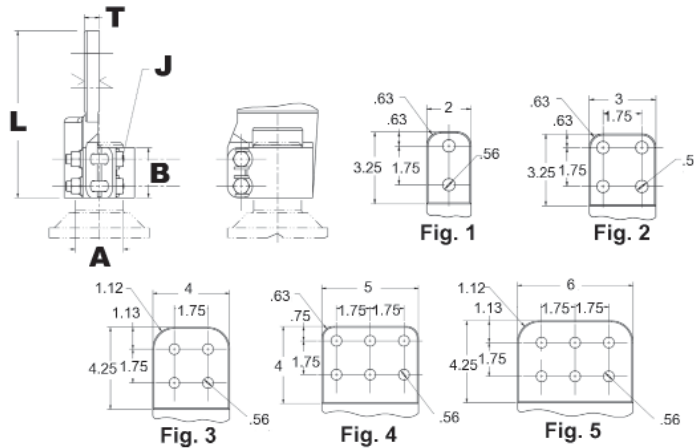
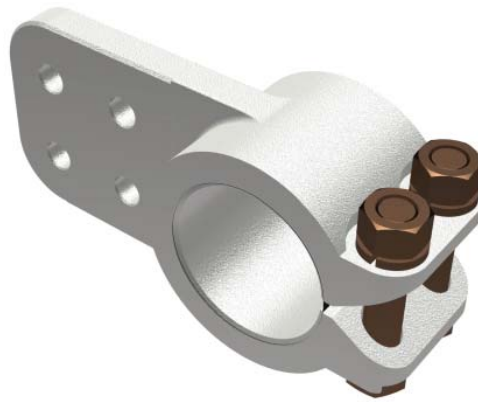

Catalog Number	Fig. #	Stud A	Threads per inch	Nominal Ampere Rating	B	J Dia.	L	T
FD655AD6	3	1-1/8	12	1300	1.75	3/8	6.80	.38
FD655AC6	3			1075	1.75	3/8	5.80	.38
FD67AD8	3	1-1/2		1450	2.25	1/2	7.63	.50
FD67AC6	3			1075	2.25	1/2	6.25	.38
FD68AD8	3	2		1450	2.25	1/2	7.63	.50
FD68AD12	3			2100	2.25	1/2	7.63	.75
FD70AD12	3	3		2100	2.88	5/8	8.46	.75

**TYPE ND-A-T
STUD CONNECTOR**

For Use On STUD TO PIPE

Aluminum stud connector for joining a wide range of aluminum pipe. Contains high strength aluminum hardware. Unique groove design provides maximum around on all pipes accommodated. Stud element can be bolted to aluminum stud with PENETROX™ A.



Material: Aluminum Alloy
Hardware: Aluminum Hardware

Notes :

- PENETROX™ A joint compound is recommended on contact surfaces
- Scratch brush connector contact surface, dry then apply an oxide inhibitor. PENETROX™ A can be purchased from BURNDY® in cans or plastic squeeze bottles.

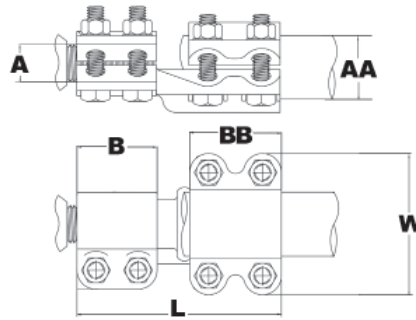

Catalog Number	Stud A	AA - tube	Threads per inch	B	BB	L	W
ND6717AT12	1-1/2	1 1/2 IPS	12	2.69	2.69	6.00	3.64
ND6516AT14	1	1 1/4 IPS	14		2.69	6.25	3.50
ND6716AT12	1-1/2		1 IPS	12	2.25	3.75	7.00
ND6715AT12		2 1/2 IPS	12	4.00	2.25	6.75	4.63
ND6719AT12GS		1-1/4	2 IPS	12	2.69	2.69	6.07
ND6718AT12	1-1/2	12		2.25	4.25	7.50	4.50
ND65518AT12	1-1/8	12			4.25	7.25	

TYPE NDR-AT STUD CONNECTOR

For Use On STUD TO CABLE

Clamp type aluminum alloy in-line stud connector which accommodates a broad range of aluminum or ACSR cables. Bolt heads are recessed in body of cable element to provide one wrench installation. Unique groove design provides maximum around on all cables accommodated. Bellied mouth eliminates cable chafing.



Material: Aluminum Alloy
Hardware: Aluminum Hardware

Notes :

- Properly proportioned to minimize conductor corrosion due to galvanic action. When properly used, this item does not require use of bimetallic plates. Please ask BURNDY® Technical Support for recommendations
- PENETROX™ A joint compound is recommended on contact surfaces
- Please contact factory for other sizes, combinations and availability
- One-wrench installation.

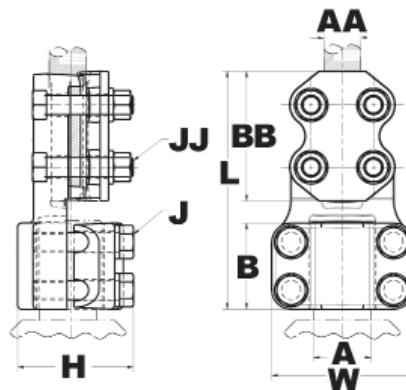

Catalog Number	Stud A	AA - Stranded Cable	AA - ACSR Cable	B	BB	J Dia.	JJ Dia.	L	H	W
NDR6325AT13	1/2	4 AWG-1/0 AWG	4 (6/1) Swan AWG-1/0 (6/1) Raven AWG	2.06	2.03	1/2	1/2	4.5	2.25	2.28
NDR6329AT13	1/2	1/0 AWG-250 kcmil	1/0 (6/1) Raven AWG-4/0 (6/1) Penquin AWG	2.06	2.75	1/2	1/2	5.38	2.56	2.50
NDR6332AT13	1/2	250 kcmil-400 kcmil	4/0 (6/1) Penquin AWG-397.5 (30/7) Larkspur kcmil	2.06	3.00	1/2	1/2	5.62	2.56	2.63
NDR6432AT0	3/4	250 kcmil-400 kcmil	4/0 (6/1) Penquin AWG-397.5 (30/7) Larkspur kcmil	2.06	3.00	1/2	1/2	5.62	2.56	2.63
NDR6432AT16	3/4	250 kcmil-400 kcmil	4/0 (6/1) Penquin AWG-397.5 (30/7) Larkspur kcmil	2.06	3.00	1/2	1/2	5.62	2.56	2.63
NDR6436AT16	3/4	350 kcmil-600 kcmil	336.4 (18/1) Merlin kcmil-795 (30/19) Mallard kcmil	2.06	3.25	1/2	1/2	5.88	2.56	2.75
NDR6536AT14	1	350 kcmil-600 kcmil	336.4 (18/1) Merlin kcmil-795 (30/19) Mallard kcmil	2.06	3.25	1/2	1/2	5.88	2.63	2.94
NDR6542AT14	1	600 kcmil-900 kcmil	477.0 (18/1) Pelican kcmil-795 (30/19) Mallard kcmil	2.06	3.50	1/2	1/2	6.12	3.12	3.00
NDR65529AT0	1-1/8	1/0 AWG-250 kcmil	1/0 (6/1) Raven AWG-4/0 (6/1) Penquin AWG	2.25	2.75	1/2	1/2	5.62	2.75	3.06
NDR65529AT12	1-1/8	1/0 AWG-250 kcmil	1/0 (6/1) Raven AWG-4/0 (6/1) Penquin AWG	2.25	2.75	1/2	1/2	5.63	2.69	3.06

TYPE NDR-AT STUD CONNECTOR

(Continued)

For Use On STUD TO CABLE



Catalog Number	Stud A	AA - Stranded Cable	AA - ACSR Cable	B	BB	J Dia.	JJ Dia.	L	H	W
NDR65536AT12	1-1/8	350 kcmil-600 kcmil	336.4 (18/1) Merlin kcmil-795 (30/19) Mallard kcmil	2.25	3.25	1/2	1/2	6.13	2.69	3.06
NDR65542AT12	1-1/8	600 kcmil-900 kcmil	477.0 (18/1) Pelican kcmil-795 (30/19) Mallard kcmil	2.25	3.75	1/2	1/2	6.63	3.25	3.19
NDR65545AT12	1-1/8	900 kcmil-1250 kcmil	715.5 (54/7) Crow kcmil-1113 (54/19) Finch kcmil	2.25	3.75	1/2	1/2	6.62	3.25	3.19
NDR6632AT12	1-1/4	250 kcmil-400 kcmil	4/0 (6/1) Penguin AWG-397.5 (30/7) Larkspur kcmil	2.25	3.06	1/2	1/2	5.98	2.75	3.19
NDR6636AT12	1-1/4	350 kcmil-600 kcmil	336.4 (18/1) Merlin kcmil-795 (30/19) Mallard kcmil	2.13	3.25	1/2	1/2	6.12	2.75	3.19
NDR6642AT12	1-1/4	600 kcmil-900 kcmil	477.0 (18/1) Pelican kcmil-795 (30/19) Mallard kcmil	2.13	3.50	1/2	1/2	6.38	3.13	3.19
NDR6646AT12	1-1/4	1250 kcmil-1600 kcmil	1113 (54/19) Finch kcmil-1431 (54/19) Plover kcmil	2.13	4.38	1/2	5/8	7.25	3.69	3.75
NDR6732AT12	1-1/2	250 kcmil-400 kcmil	4/0 (6/1) Penguin AWG-397.5 (30/7) Larkspur kcmil	2.13	3.00	1/2	1/2	5.88	2.88	3.38
NDR6736AT12	1-1/2	350 kcmil-600 kcmil	336.4 (18/1) Merlin kcmil-795 (30/19) Mallard kcmil	2.13	3.25	1/2	1/2	6.12	2.88	3.38
NDR6742AT12	1-1/2	600 kcmil-900 kcmil	477.0 (18/1) Pelican kcmil-795 (30/19) Mallard kcmil	2.13	3.50	1/2	1/2	6.38	3.12	3.38
NDR6745AT12	1-1/2	900 kcmil-1250 kcmil	715.5 (54/7) Crow kcmil-1113 (54/19) Finch kcmil	2.13	3.75	1/2	1/2	6.62	3.19	3.38
NDR6748AT12	1-1/2	1500 kcmil-2000 kcmil	1272 (54/19) Pheasant kcmil-1780 (54/19) kcmil	2.13	4.50	1/2	5/8	7.38	3.88	3.88
NDR6836AT12	2	350 kcmil-600 kcmil	336.4 (18/1) Merlin kcmil-795 (30/19) Mallard kcmil	2.50	3.25	1/2	1/2	6.38	3.12	3.94
NDR6842AT12	2	600 kcmil-900 kcmil	477.0 (18/1) Pelican kcmil-795 (30/19) Mallard kcmil	2.5	3.50	1/2	1/2	6.62	3.38	3.94
NDR6845AT12	2	900 kcmil-1250 kcmil	715.5 (54/7) Crow kcmil-1113 (54/19) Finch kcmil	2.50	3.75	1/2	1/2	6.88	3.38	3.94

TYPE NDR-AR STUD CONNECTOR

For Use On STUD TO CABLE
(FLAG)

Clamp type aluminum alloy flag type stud connector which accommodates a broad range of aluminum or ACSR cables. Bolt heads are recessed in body of cable element to provide one wrench installation. Unique groove design provides maximum around on all cables accommodated. Belled mouth eliminates cable chafing.

Material: Aluminum Alloy
Hardware: Aluminum Hardware

Notes :

- Properly proportioned to minimize conductor corrosion due to galvanic action. When properly used, this item does not require use of bimetallic plates. Please ask BURNDY® Technical Support for recommendations
- PENETROX™ A joint compound is recommended on contact surfaces
- Please contact factory for other sizes, combinations and availability
- One-wrench installation.

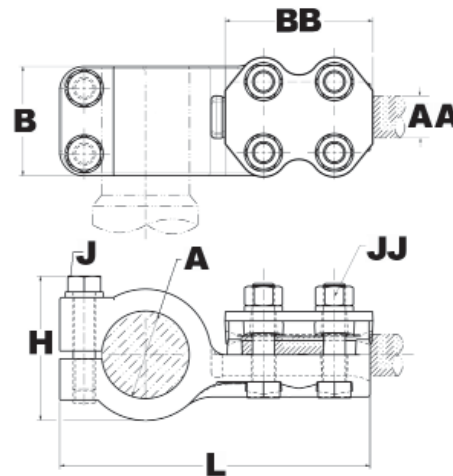

Catalog Number	Stud A	Threads per inch	AA - Stranded Cable	AA-ACSR Cable	B	BB	J Dia.	JJ Dia.	L	H
NDR6329AR13	1/2	13	1/0 AWG-250 kcmil	1/0 (6/1) Raven AWG-4/0 (6/1) Penquin AWG	2.03	2.88	1/2	1/2	5.37	2.62
NDR65536AR12	1-1/8	12	350 kcmil-600 kcmil	336.4 (18/1) Merlin kcmil-477. (30/7) Hen kcmil	2.25	3.38	1/2	1/2	6.62	2.75
NDR65542AR12	1-1/8	12	600 kcmil-900 kcmil	477.0 (18/1) Pelican kcmil-795 (30/19) Mallard kcmil	2.25	3.62	1/2	1/2	6.75	3.12
NDR65545AR12	1-1/8	12	900 kcmil-1250 kcmil	715.5 (54/7) Crow kcmil-1113 (54/19) Finch kcmil	2.25	2.25	1/2	1/2	7.12	3.25
NDR6732AR12GS	1-1/2	12	250 kcmil-400 kcmil	4/0 (6/1) Penquin AWG-397.5 (30/7) Larkspur kcmil	2.25	2.88	1/2	1/2	6.63	2.88
NDR6742AR12	1-1/2	12	600 kcmil-900 kcmil	477.0 (18/1) Pelican kcmil-795 (30/19) Mallard kcmil	3.50	6.94	1/2	1/2	7.12	3.12
NDR6845AR12	2	12	900 kcmil-1250 kcmil	715.5 (54/7) Crow kcmil-1113 (54/19) Finch kcmil	2.50	8.00	1/2	1/2	8.00	3.38

**TYPE N2DR-AT
STUD CONNECTOR**

For Use On STUD TO (2)
CABLES



Clamp type aluminum alloy in-line stud connector which accommodates a broad range of aluminum or ACSR cables. Bolt heads are recessed in body of cable element to provide one wrench installation. Unique groove design provides maximum around on all cables accommodated. Belled mouth eliminates cable chafing.

Material: Aluminum Alloy
Hardware: Aluminum Hardware

Notes :

- Properly proportioned to minimize conductor corrosion due to galvanic action. When properly used, this item does not require use of bimetallic plates. Please ask BURNDY® Technical Support for recommendations
- PENETROX™ A joint compound is recommended on contact surfaces
- Please contact factory for other sizes, combinations and availability
- One-wrench installation.

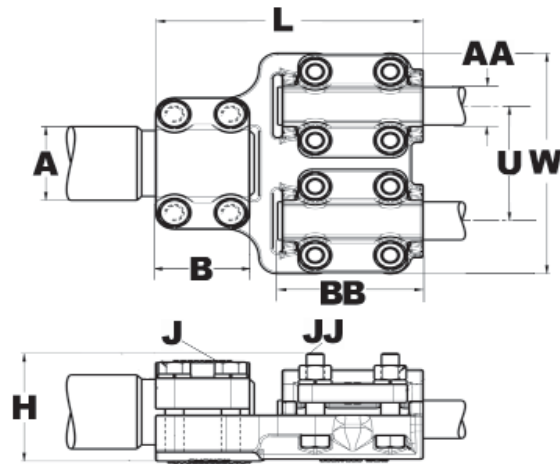

Catalog Number	Stud A	AA - Stranded Cable	AA-ACSR Cable	B	Threads per inch	J Dia.	BB	JJ Dia.	U	L	H	W
N2DR6748AT12	1-1/2	1500 kcmil- 2000 kcmil	1272 (54/19) Pheasant kcmil- 1780 (54/19) kcmil	2.25	12	1/2	4.50	5/8	4.12	7.50	2.88	8.00

**TYPE N2DR-AR
STUD CONNECTOR**

For Use On STUD TO (2)
CABLES (FLAG)

Clamp type aluminum alloy stud connector which accommodates a broad range of aluminum or ACSR cables. Bolt heads are recessed in body of cable element to provide one wrench installation. Unique groove design provides maximum around on all cables accommodated. Bell-ed mouth eliminates cable chafing.



Material: Aluminum Alloy
Hardware: Aluminum Hardware

Notes :

- Properly proportioned to minimize conductor corrosion due to galvanic action. When properly used, this item does not require use of bimetallic plates. Please ask BURNDY® Technical Support for recommendations
- PENETROX™ A joint compound is recommended on contact surfaces
- One-wrench installation

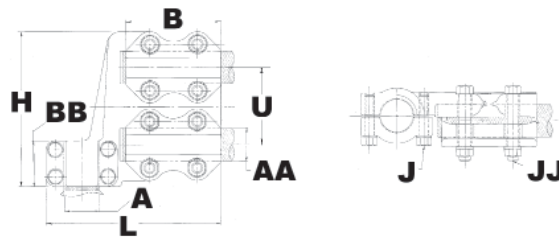

Catalog Number	Stud A	AA - Stranded Cable	AA - ACSR Cable	B	Threads per inch	J Dia.	JJ Dia.	U	L	H
N2DR6848AR12	2	N/A	1272 (54/19) Pheasant kcmil-1780 (54/19) kcmil	2.50	12	1/2	5/8	4.12	8.92	8.00

**TYPE XD-AT
EXPANSION STUD
CONNECTOR**

For Use On EXPANSION STUD TO PIPE

Aluminum alloy expansion in-line stud connector for joining tube to copper or aluminum equipment stud. Flexible aluminum straps allow for longitudinal or lateral movement and carries full current load of the joint.

Material: Aluminum Alloy
Hardware: Aluminum Hardware

Notes :

- Please contact factory for other sizes, combinations and availability
- Installation instructions available upon request
- PENETROX™ A joint compound is recommended on contact surfaces
- One-wrench installation.

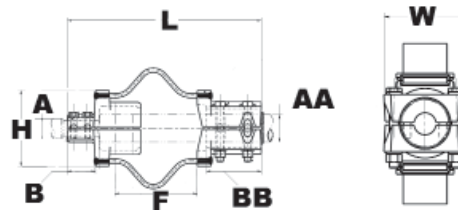

Catalog Number	Stud A	AA - tube Schd 40	Threads per inch	B	BB	L	H	W
XD65515AT12	1-1/8	1 IPS	12	2.25	3.50	12.63	3.75	3.06
XD6717AT12	1-1/2	1 1/2 IPS	12		4.00	13.91	4.50	3.64
XD6718AT12		2 IPS	12		4.25	14.64	5.26	4.50
XD6716AT12		1 1/4 IPS	12		3.75	12.62	4.00	3.40
XD6720AT12		3 IPS	12		5.00	17.48	6.80	5.62
XD6859AT12	2	2 1/2 IPS	12	2.50	4.50	16.34	5.90	5.00
XD6817AT12		1 1/2 IPS	12		4.00	14.13	4.50	5.62

**TYPE XD-AR
EXPANSION STUD
CONNECTOR**

For Use On EXPANSION STUD TO PIPE (FLAG)

Aluminum alloy flag type expansion stud connector for joining tube to copper or aluminum equipment stud. Flexible aluminum straps allow for longitudinal or lateral movement and carries full current load of the joint.

Material: Aluminum Alloy
Hardware: Aluminum Hardware

Notes :

- Please contact factory for other sizes, combinations and availability
- Installation instructions available upon request
- PENETROX™ A joint compound is recommended on contact surfaces

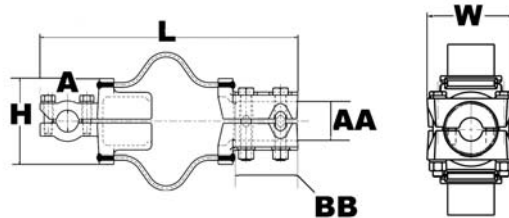
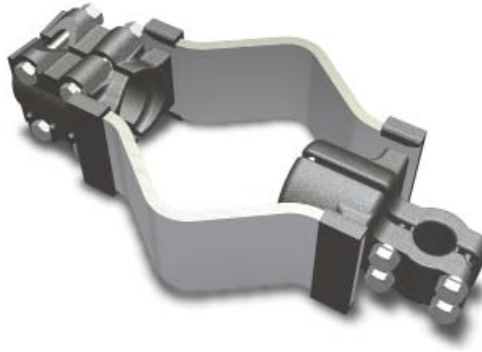

Catalog Number	Stud A	AA - tube Schd 40	Threads per inch	BB	L	H	W
XD6715AR12	1-1/2	1 IPS	12	3.50	12.53	3.70	3.06
XD6717AR12		1 1/2 IPS	12	4.00	15.08	4.50	3.64
XD6718AR12		2 IPS	12	4.25	15.72	5.26	4.50
XD6722AR12GS		4 IPS	12	6.00	22.75	8.16	6.63
XD6818AR12	3	2 IPS	12	4.25	16.25	5.26	4.50
XD6817AR12	2	1 1/2 IPS	12		14.13	4.13	3.64
XD6823AR12		4 1/2 IPS	12	6.50	22.77	9.60	7.13
XD7022AR12	3	4 IPS	12	6.00	22.76	8.16	6.62

**TYPE SFD
STUD CONNECTOR**

For Use On STUD TO PAD

Aluminum alloy stud connector for equipment bushing to conductor terminals. One wrench installation. Unless otherwise mentioned at the item level, this design embeds principles for self-shielding up to 550kV.



Material: Aluminum Alloy
Hardware: Aluminum Hardware
(Modified by Hardware suffixes)

Notes :

- Properly proportioned to minimize conductor corrosion due to galvanic action. When properly used, this item does not require use of bimetallic plates. Please ask BURNDY® Technical Support for recommendations
- PENETROX™ A joint compound is recommended on contact surfaces
- Please contact factory for other sizes, combinations and availability
- Use shielding caps for high voltage applications (STS family). Shielding caps may be purchased separately
- Pad is finished on both sides

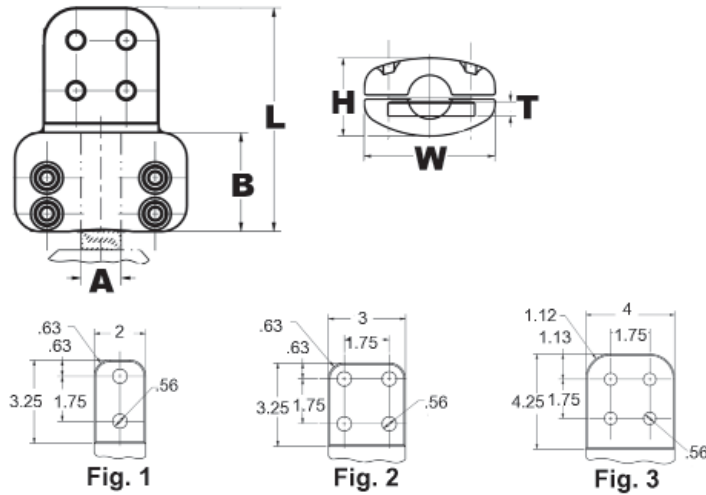

Catalog Number	Fig. #	Stud A	Threads per inch	B	H	L	W	T
SFD67D12	3	1-1/2	12	2.50	2.79	7.66	4.50	.75
SFD68AD16	3	2		3.45	3.57	8.23	6.00	1.00
SFD69AD16	3	2-1/2		3.45	3.57	8.23	6.00	1.00
SFD70AD16	3	3		3.84	4.10	8.59	7.12	1.00
SFD71AD20	3	3-1/2		3.84	4.89	8.59	7.50	1.25
SFD71AD16	3			3.84	4.89	8.59	7.50	1.00
SFD72AD20	3	4		3.84	5.37	8.58	8.12	1.25
SFD72AD18	3			3.84	5.37	8.58	8.12	1.12

**TYPE SND-AR
STUD CONNECTOR**

For Use On STUD TO CABLE
(FLAG)

Streamlined stud connector for joining a wide range of aluminum cables to equipment studs. One wrench installation.



Material: Aluminum Alloy
Hardware: Aluminum Hardware
(Modified by Hardware suffixes)

Notes :

- Please contact factory for other sizes, combinations and availability
- PENETROX™ A joint compound is recommended on contact surfaces

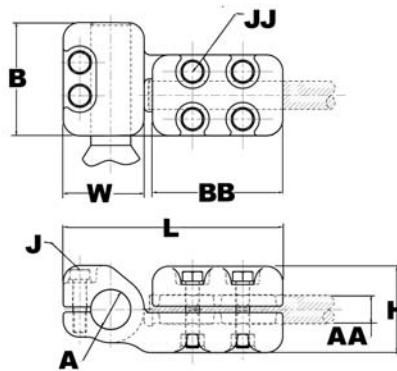

Catalog Number	Stud A	AA - Cable	Threads per inch	B	J Dia.	BB	JJ Dia.	L	H	W
SND6744AR12S3GS	1-1/2	954 kcmil	12	3.03	1/2	4.88	1/2	8.22	3.24	4.25
SND6747AR12S3HQ		1800 kcmil	12	3.44	1/2	6.76		10.48	3.59	4.94
SND6741AR12S3SS		795 kcmil	12	30.3	1/2	4.88		8.22	3.24	4.25

**TYPE SND-AT
STUD CONNECTOR**

For Use On STUD TO CABLE

Streamlined stud connector for joining a wide range of aluminum cables to equipment studs. One wrench installation.



Material: Aluminum Alloy
Hardware: Aluminum Hardware
(Modified by Hardware suffixes)

Notes :

- PENETROX™ A joint compound is recommended on contact surfaces
- Scratch brush connector contact surface, dry then apply an oxide inhibitor. PENETROX™ A can be purchased from BURNDY® in cans or plastic squeeze bottles.

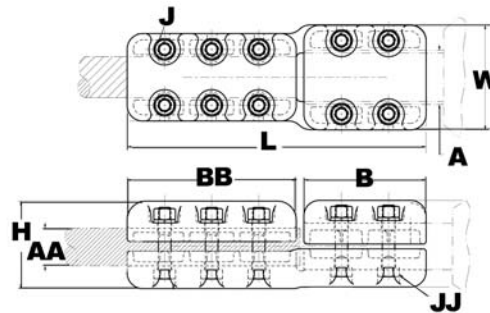

Catalog Number	Stud A	Threads per inch	AA - Cable	B	J Dia.	BB	JJ Dia.	L	H	W
SND6744AT12S3GS	1-1/2	12	954 kcmil	4.25	1/2	4.88	1/2	9.44	3.38	3.03
SND6747AT12S3HQ			1800 kcmil	4.88	1/2	6.75		2.50	3.75	3.38
SND6847AT12S3HQ	2		1800 kcmil	1/2	6.75	2.50		3.47	4.19	

**TYPE SN2D-AR-S7
STUD CONNECTOR**

For Use On STUD TO (2)
CABLES, FLAG

Aluminum stud connector for joining aluminum pipe to equipment stud. Contains high strength aluminum hardware flag configuration. Unique groove design provides maximum around on all pipes accommodated. Streamlined for 765 kV application.

Material: Aluminum Alloy
Hardware: Aluminum Hardware

Notes :

- Please contact factory for other sizes, combinations and availability
- PENETROX™ A joint compound is recommended on contact surfaces

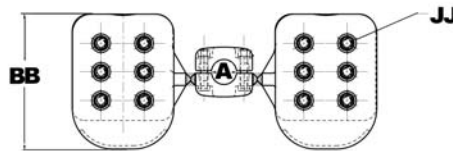
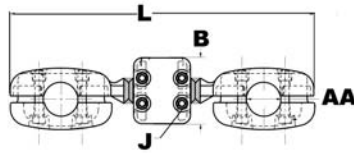

Catalog Number	Stud A	AA - Cable	B	Threads per inch	J Dia.	BB	JJ Dia.	L
SN2D68496AR015S7SS	2	4000 kcmil	7.88	12	5/8	4.88	1/2	10.00
SN2D68496AR1215S7SS	12		7.88		5/8			10.00

**TYPE SN2D-ARS3
STUD CONNECTOR**

For Use On STUD TO (2)
CABLE

Aluminum stud connector for joining aluminum pipe to equipment stud. Contains high strength aluminum hardware flag configuration. Unique groove design provides maximum around on all pipes accommodated. Streamlined for 345 kV application.

Material: Aluminum Alloy
Hardware: Aluminum Hardware

Notes :

- Please contact factory for other sizes, combinations and availability
- PENETROX™ A joint compound is recommended on contact surfaces

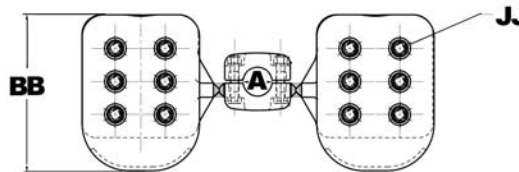
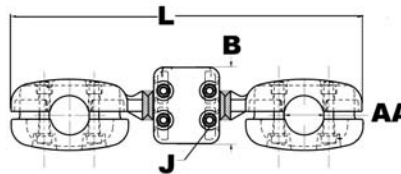
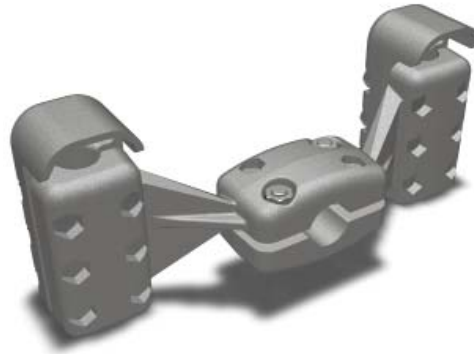

Catalog Number	Stud A	AA - Cable	B	Threads per inch	J Dia.	BB	JJ Dia.	L
SN2D6847AR1215S3	2	1800 kcmil	3.50	12	1/2	6.50	1/2	8.06

**TYPE SN2D-AT-S3
STUD CONNECTOR**

For Use On STUD TO (2)
CABLES

Aluminum alloy flag type expansion stud connector for joining tube to copper or aluminum equipment stud. Flexible aluminum straps allow for longitudinal or lateral movement and carries full current load of the joint. Streamlined for 345kV application.

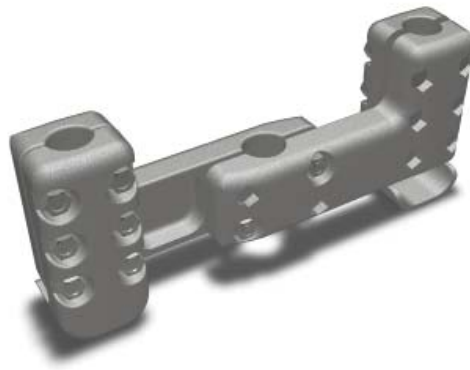

Material: Aluminum Alloy
Hardware: Aluminum Hardware

Notes :

- Please contact factory for other sizes, combinations and availability
- PENETROX™ A joint compound is recommended on contact surfaces

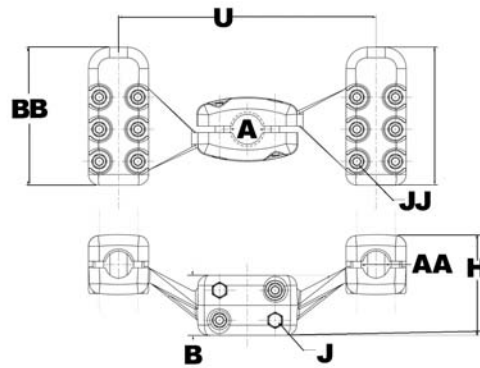

Catalog Number	Stud A	AA - Cable	B	Threads per inch	J Dia.	U	BB	JJ Dia.	H
SN2D6847AT1215S3	2	1800 kcmil	3.50	12	1/2	15.00	6.50	1/2	3.62

**TYPE SN2D-AT-S7
STUD CONNECTOR**

For Use On STUD TO (2)
CABLE

Aluminum stud connector for joining aluminum cable to equipment stud. Contains high strength aluminum hardware flag configuration. Unique groove design provides maximum around on all pipes accommodated. Streamlined for 765 kV application.

Material: Aluminum Alloy
Hardware: Aluminum Hardware

Notes :

- Please contact factory for other sizes, combinations and availability
- PENETROX™ A joint compound is recommended on contact surfaces

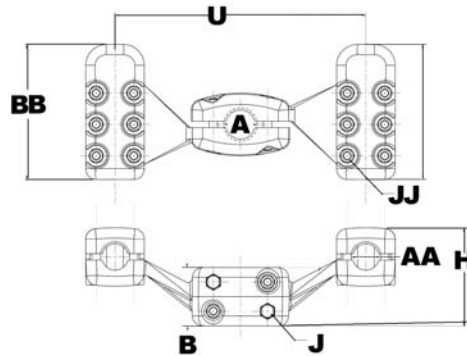
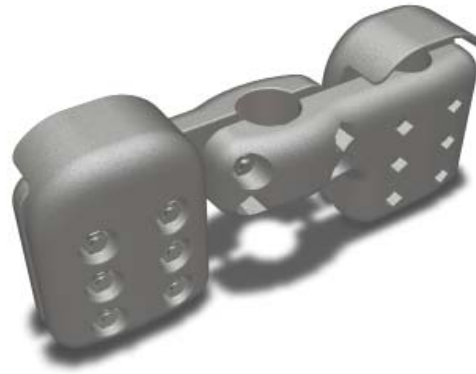

Catalog Number	Stud A	AA - Cable	Threads per inch	B	J Dia.	U	BB	JJ Dia.	H
SN2D70496AT1215S7	3	4000 kcmil	12	4.00	5/8	15.00	3.50	5/8	5.75

**TYPE SNN2D
STUD CONNECTOR**

For Use On STUD TO TWO
CABLES

Streamlined aluminum alloy stud connector for joining two cables to equipment studs.

Material: Aluminum Alloy
Hardware: Aluminum Hardware

Notes :

- Please contact factory for other sizes, combinations and availability
- PENETROX™ A joint compound is recommended on contact surfaces

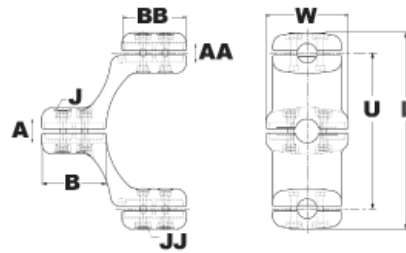

Catalog Number	Stud A	AA - Cable	Threads per inch	B	J Dia.	U	BB	JJ Dia.	L	W
SNN2D68486AT12L13BCH	2	2300 kcmil	12	5.48	1/2	13.00	6.62	5/8	19.62	8.00
SNN2D6848AT0L13GS		2000 kcmil	*	5.50	1/2	13.00	5.38	1/2	12.10	6.90
SNN2D69495AT12L6S2BCH	5/2	3500 kcmil	12	4.88	1/2	6.00	6.50	1/2	12.00	5.00
SNN2D70495AT12L6S2BCH	3		12		1/2	6.00		1/2	12.00	5.00

* Smooth stud

**TYPE SXD-T
STUD CONNECTOR**

For Use On EXPANSION STUD TO PIPE

Aluminum alloy streamlined expansion stud connector for joining tube to copper or aluminum equipment stud. Flexible aluminum straps allow for longitudinal or lateral movement and carries full current load of the joint.

Material: Aluminum Alloy
Hardware: Aluminum Hardware

Notes :

- Pad is finished on both sides
- Please contact factory for other sizes, combinations and availability
- PENETROX™ A joint compound is recommended on contact surfaces

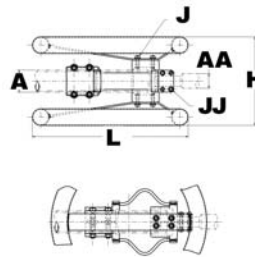

Catalog Number	Stud A	AA - tube	Threads per inch	J Dia.	JJ Dia.	L	H
SXD6821AT12CG1	2	3 1/2 IPS	12	5/8	1/2	28.00	16.00

Table of Contents - Aluminum Bolted Rigid Spacers

	Type CP Rigid Cable Spacer	A-135
	Type CPR Rigid Cable Spacer	A-136
	Type S2GBP Rigid Cable Spacer	A-137
	Type S2GBP-B2 Rigid Cable Spacer	A-139
	Type S2GBP-B4 Rigid Cable Spacer	A-140
	Type S2GGBP Rigid Cable Spacer with Grounding Rod	A-141
	Type S2GBPA Rigid Cable Spacer with Tap Pad	A-142
	Type S2GBPA-B2 Rigid Cable Spacer with Tap Pad	A-143
	Type S2GBPA-B4 Rigid Cable Spacer with Tap Pad	A-144
	Type SH2GBP Rigid Cable Spacer with Insulator Mount	A-145
	Type SH2GBP-B2	A-146
	Type SH2GBPA-B4 Rigid Cable Spacer with Tap Pad (4 Bolt Cap)	A-147

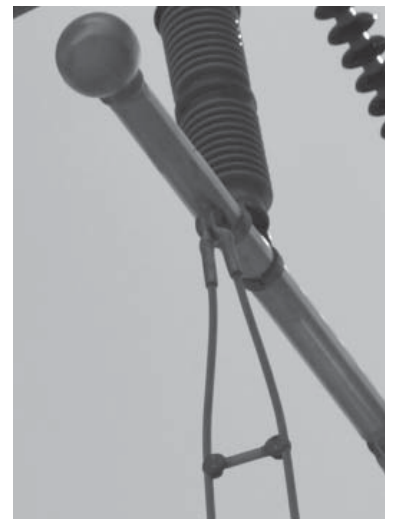
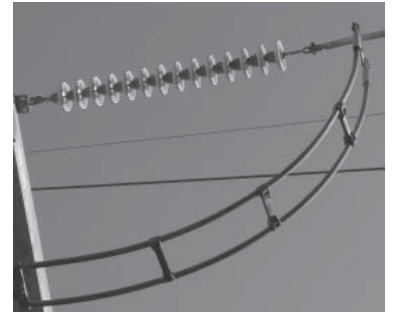

Table of Contents - Aluminum Bolted Rigid Spacers (continued)



Type CP3R Rigid Cable Spacer
(3 Bundle)

A-148



Type S3GBP Rigid Cable Spacer

A-149



Type S3GBPA Rigid Cable Spacer
with Tap Pad

A-150



Type S3GBPB2 Rigid Cable Spacer

A-151



Type SH3GBP Rigid Cable Spacer
with Insulator Mount

A-152



Type S3GGBP Rigid Cable Spacer
with Grounding Rod

A-153



Type S4GBP Rigid Cable Spacer

A-154



Type SH4GBP Rigid Cable Spacer
with Insulator Mount

A-155

**TYPE CP
SPACER**

For Use On (2) CABLE RIGID
SPACER

Rigid spacer for large range of cables.
Particularly appropriate design for
short spacing with more contact
control (larger contact surface, 2
bolts).

Material: Aluminum Alloy
Hardware: Aluminum Hardware

Notes :

- PENETROX™ A joint compound is recommended on contact surfaces
- Please contact factory for other sizes, combinations and availability.

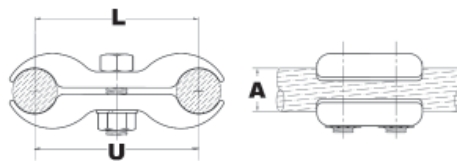

Catalog Number	Aluminum Stranded	Aluminum ACSR	L
CP4444L4	1000 kcmil	N/A	4.00
CP44AL4	900 kcmil-1000 kcmil	874.5 (54/7) Crane kcmil-	
CP44AL6	900 kcmil-1000 kcmil	954 (54/7) Cardinal kcmil	6.00
CP45AL4	1200 kcmil-1300 kcmil	1033.5 (45/7) Ortolan kcmil-	4.00
CP45AL6	1200 kcmil-1300 kcmil		1113 (54/19) Finch kcmil
CP48AL4	1700 kcmil-2000 kcmil	1590 (54/19) Falcon kcmil	4.00
CP48AL6	1700 kcmil-2000 kcmil		6.00

**TYPE CPR
SPACER**

For Use On (2) CABLE RIGID
SPACER

Rigid spacer for large range of cables.
Particularly appropriate design for
short spacing (up to 6" or 8").

Material: Aluminum Alloy
Hardware: Aluminum Hardware

Notes :

- PENETROX™ A joint compound is recommended on contact surfaces
- One wrench installation
- Please contact factory for other sizes, combinations and availability.

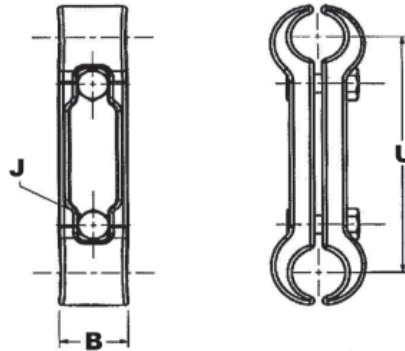

Catalog Number	Aluminum Stranded	B	J Dia.	U
CPR34A4	500 kcmil	1.75	1/2	4.00
CPR42A4	600 kcmil-900 kcmil			4.00
CPR46A4	1200 kcmil-1600 kcmil	2.13	5/8	4.00

**TYPE S2GBP
SPACER**

For Use On (2) CABLE RIGID
SPACER

Streamlined rigid spacer for large range of cables. Particularly appropriate for 8"+ spacing. 1 bolt per clamping module version.

EHV RATED: SELF-SHIELDING UP TO 550kV

Material: Aluminum Alloy
Hardware: Aluminum Hardware

Notes :

- PENETROX™ A joint compound is recommended on contact surfaces
- One wrench installation
- Please contact factory for other sizes, combinations and availability.

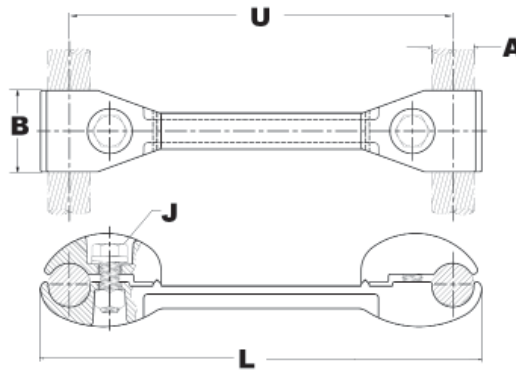

Catalog Number	Aluminum Stranded	Aluminum ACSR	B	J Dia.	U	L
S2GBP36A	350 kcmil-600 kcmil	336.4 (18/1) Merlin kcmil-477 (30/7) Hen kcmil	3	5/8	18	19.62
S2GBP36A8	350 kcmil-600 kcmil	336.4 (30/7) Oriole kcmil-477 (30/7) Hen kcmil		5/8	8	9.62
S2GBP41A	795 kcmil-874 kcmil	715.5 (24/7) Stilt kcmil-715.5 (26/7) Starling kcmil		5/8	18	18
S2GBP41A12	795 kcmil-874 kcmil	715.5 (26/7) Starling kcmil		5/8	12	12
S2GBP41A8	795 kcmil-874 kcmil	715.5 (24/7) Stilt kcmil-715.5 (26/7) Starling kcmil		5/8	8	9.68
S2GBP445A	1033 kcmil-1113 kcmil	954 (45/7) Rail kcmil-1033.5 (45/7) Ortolan kcmil		5/8	18	19.76
S2GBP445A12	1033 kcmil-1113 kcmil			5/8	12	12
S2GBP445A16	1033 kcmil-1113 kcmil			5/8	16	17.68
S2GBP445A8	1033 kcmil-1113 kcmil			5/8	8	9.68
S2GBP44A	954 kcmil	795 (54/7) Condor kcmil-874.5 (54/7) Crane kcmil		5/8	18	19.68
S2GBP44A8	954 kcmil			5/8	8	9.68
S2GBP44A9	954 kcmil			5/8	9	10.68
S2GBP45A	1192 kcmil-1272 kcmil	1033.5 (45/7) Ortolan kcmil-1192.5 (45/7) Bunting kcmil		5/8	18	20.32

**TYPE S2GBP
SPACER (Continued)**

For Use On (2) CABLE RIGID
SPACER



Catalog Number	Aluminum Stranded	Aluminum ACSR	B	J Dia.	U	L
S2GBP45A12	1192 kcmil- 1272 kcmil	1033.5 (45/7) Ortolan kcmil- 1192.5 (54/19) Grackle kcmil	3	5/8	12	14.32
S2GBP46A	1590 kcmil- 1600 kcmil	1272 (54/19) Pheasant kcmil- 1431 (54/19) Plover kcmil		5/8	18	20.30
S2GBP46A12	1590 kcmil- 1600 kcmil			5/8	12	14.30
S2GBP46A8	1590 kcmil- 1600 kcmil			5/8	8	10.30
S2GBP46A9	1590 kcmil- 1600 kcmil			5/8	9	11.30
S2GBP483A	2000 kcmil- 2250 kcmil			2034.5 (72/7) Mockingbird kcmil	5/8	18
S2GBP483A12	2000 kcmil- 2250 kcmil	5/8			12	14.50
S2GBP483A8	2000 kcmil- 2250 kcmil	5/8			8	10.50
S2GBP486A	2300 kcmil- 2500 kcmil	2156 (84/19) Bluebird kcmil- 2167 (72/7) Kiwi kcmil	4	5/8	18	20.38
S2GBP486A12	2300 kcmil- 2500 kcmil			5/8	12	14.38
S2GBP486A13	2300 kcmil- 2500 kcmil			5/8	13	15.52
S2GBP486A8	2300 kcmil- 2500 kcmil			5/8	8	10.52
S2GBP48A	1750 kcmil- 2000 kcmil	1590 (45/7) Lapwing kcmil- 1780 (84/19) Chukar kcmil	3	5/8	18	20.30
S2GBP48A12	1750 kcmil- 2000 kcmil		4	5/8	12	14.30
S2GBP48A8	1750 kcmil- 2000 kcmil		3	5/8	8	10.30
S2GBPA486A	2300 kcmil- 2500 kcmil	2156 (84/19) Bluebird kcmil- 2167 (72/7) Kiwi kcmil	4	5/8	18	20.38
S2GBPA486A8	2300 kcmil- 2500 kcmil			5/8	8	10.52

**TYPE S2GBP-B2
SPACER**

For Use On (2) CABLE RIGID
SPACER

Streamlined rigid spacer for large range of cables. Particularly appropriate for 8"+ spacing. 2 bolts per clamping module version for additional clamping strength.

EHV RATED: SELF-SHIELDING UP TO 550kV

Material: Aluminum Alloy
Hardware: Aluminum Hardware

Notes :

- Properly proportioned to minimize conductor corrosion due to galvanic action. When properly used, this item does not require use of bimetallic plates. Please ask BURNDY® Technical Support for recommendations
- PENETROX™ A joint compound is recommended on contact surfaces
- Please contact factory for other sizes, combinations and availability.

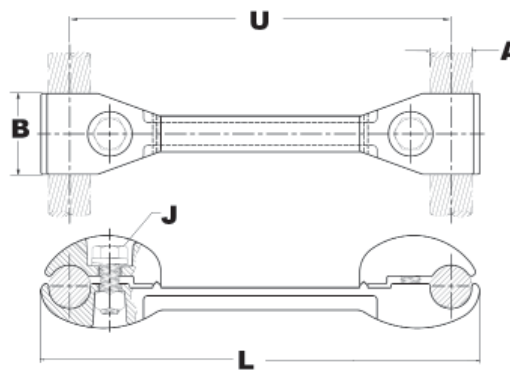

Catalog Number	Aluminum Stranded	Aluminum ACSR	B	J Dia.	U	L
S2GBP41A12B2	795 kcmil-874 kcmil	715.5 (24/7) Stilt kcmil- 715.5 (26/7) Starling kcmil	4	5/8	12	13.44
S2GBP41AB2	795 kcmil-874 kcmil			5/8	18	19.44
S2GBP445A12B2	1033 kcmil-1113 kcmil	954 (45/7) Rail kcmil- 1033.5 (45/7) Ortolan kcmil		5/8	12	13.76
S2GBP445A8B2	1033 kcmil-1113 kcmil			5/8	8	9.76
S2GBP445AB2	1033 kcmil-1113 kcmil			5/8	18	19.76
S2GBP44A12B2	954 kcmil	795 (54/7) Condor kcmil		5/8	12	13.68
S2GBP45A12B2	954 kcmil	795 (54/7) Condor kcmil- 874.5 (54/7) Crane kcmil		5/8	12	13.84
S2GBP46A12B2	1590 kcmil-1600 kcmil	1272 (54/19) Pheasant kcmil- 1431 (54/19) Plover kcmil		5/8	12	14.3
S2GBP483A12B2	2000 kcmil-2250 kcmil	1780 (84/19) Chukar kcmil- 2167 (72/7) Kiwi kcmil		5/8	12	14.76
S2GBP486A12B2	2300 kcmil-2500 kcmil	2156 (84/19) Bluebird kcmil- 2167 (72/7) Kiwi kcmil		5/8	12	14.52
S2GBP486A18B2	2300 kcmil-2500 kcmil			5/8	18	20.52
S2GBP486A9B2	2300 kcmil-2500 kcmil			5/8	9	11.52
S2GBP48A12B2	1750 kcmil-2000 kcmil	1590 (54/19) Falcon kcmil- 1780 (84/19) Chukar kcmil		5/8	12	14.30
S2GBP48A12B2SS	1750 kcmil-2000 kcmil			5/8	12	14.30
S2GBP48AB2	1750 kcmil-2000 kcmil			5/8	18	20.30

**TYPE S2GBP-B4
SPACER**

For Use On (2) CABLE RIGID
SPACER



Streamlined rigid spacer for large range of cables. Particularly appropriate for 8"+ spacing. Version with 4 bolts per clamping module - 2 on each side - for ideal clamping of the cable .

EHV RATED: SELF-SHIELDING UP TO 550kV

Material: Aluminum Alloy
Hardware: Aluminum Hardware

Notes :

- PENETROX™ A joint compound is recommended on contact surfaces
- One wrench installation
- Please contact factory for other sizes, combinations and availability.

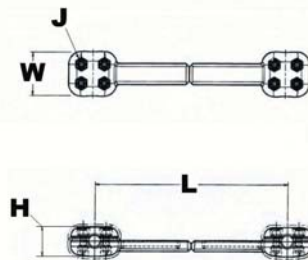

Catalog Number	Aluminum Stranded	Aluminum ACSR	J Dia.	L	H	W
S2GBP41A12B4	795 kcmil-874 kcmil	715.5 (24/7) Stilt kcmil- 715.5 (26/7) Starling kcmil	1/2	16.40	2.87	4.00
S2GBP41AB4	795 kcmil-874 kcmil			22.40	2.87	4.00
S2GBP445A12B4	1033 kcmil-1113 kcmil	954 (45/7) Rail kcmil- 1033.5 (45/7) Ortolan kcmil		16.60	2.74	4.00
S2GBP445AB4	1033 kcmil-1113 kcmil			22.60	2.74	4.00
S2GBP44A12B4	954 kcmil	795 (54/7) Condor kcmil- 874.5 (54/7) Crane kcmil		16.52	2.71	4.00
S2GBP44AB4	954 kcmil	795 (26/7) Drake kcmil- 874.5 (54/7) Crane kcmil		22.52	2.71	4.00
S2GBP45A12B4	1192 kcmil-1272 kcmil	1033.5 (54/7) Curlew kcmil- 1192.5 (54/19) Grackle kcmil		16.74	2.70	4.00
S2GBP45AB4	1192 kcmil-1272 kcmil	1033.5 (54/7) Curlew kcmil- 1192.5 (45/7) Bunting kcmil		22.74	2.70	4.00
S2GBP46A12B4	1590 kcmil-1600 kcmil	1272 (54/19) Pheasant kcmil- 1431 (54/19) Plover kcmil		16.86	2.94	4.00
S2GBP483A12B4	2000 kcmil-2250 kcmil	1780 (84/19) Chukar kcmil- 2167 (72/7) Kiwi kcmil		17.12	2.97	4.00
S2GBP483AB4	2000 kcmil-2250 kcmil			23.12	2.97	4.00
S2GBP486A12B4	2300 kcmil-2500 kcmil	2156 (84/19) Bluebird kcmil- 2167 (72/7) Kiwi kcmil		17.20	3.16	4.00
S2GBP486AB4	2300 kcmil-2500 kcmil			23.20	3.04	4.00
S2GBP48A12B4	1750 kcmil-2000 kcmil	1590 (45/7) Lapwing kcmil- 1780 (54/19) kcmil		17.00	2.89	4.00
S2GBP48AB4	1750 kcmil-2000 kcmil			23.00	2.89	4.00

**TYPE S2GGBP
SPACER**

For Use On (2) CABLE RIGID
SPACER WITH GROUNDING
ROD

Streamlined rigid spacer for large
range of cables. The rod joining
both cable modules is circular to
accommodate grounding clamps.

**EHV RATED: SELF-SHIELDING UP
TO 550kV**

Material: Aluminum Alloy
Hardware: Aluminum Hardware

Notes :

- PENETROX™ A joint compound is recommended on contact surfaces
- One wrench installation
- Please contact factory for other sizes, combinations and availability
- 1, 2 or 4 bolt designs available.

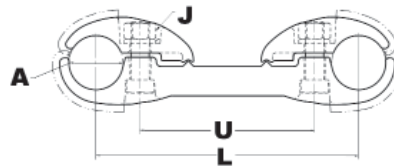
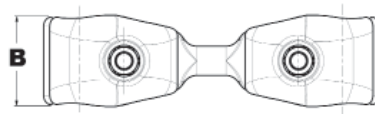

Catalog Number	Aluminum Stranded	Aluminum ACSR	B	J Dia.	U	L
S2GGBP445A12	954 kcmil- 1033 kcmil	795 (54/7) Condor kcmil- 954 (45/7) Rail kcmil	4.00	1/2	12.00	14.04
S2GGBP486A	2300 kcmil- 2500 kcmil	2156 (84/19) Bluebird kcmil- 2167 (72/7) Kiwi kcmil	3.00	5/8	18.00	20.76
S2GGBP486A9	2300 kcmil- 2500 kcmil		3.12	5/8	9.00	11.50
S2GGBP48A	1750 kcmil- 2000 kcmil	1590 (45/7) Lapwing kcmil- 1780 (54/19) kcmil	3.00	5/8	18.00	20.76
S2GGBP48A12	1750 kcmil- 2000 kcmil	1590 (54/19) Falcon kcmil- 1780 (84/19) Chukar kcmil		5/8	12.00	14.76

**TYPE S2GBPA
SPACER TERMINAL**

For Use On (2) CABLES TO
TAP PAD

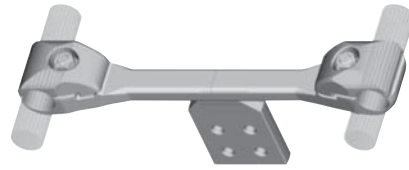

Streamlined rigid spacer for large range of cables with tap pad. Particularly appropriate for 8"+ spacing. 1 bolt per clamping module version. Pad requires STS shielding caps for EHV.

EHV RATED: SELF-SHIELDING UP TO 550kV

Material: Aluminum Alloy
Hardware: Aluminum Hardware

Notes :

- Properly proportioned to minimize conductor corrosion due to galvanic action. When properly used, this item does not require use of bimetallic plates. Please ask BURNDY® Technical Support for recommendations
- PENETROX™ A joint compound is recommended on contact surfaces
- Please contact factory for other sizes, combinations and availability
- One-wrench installation.

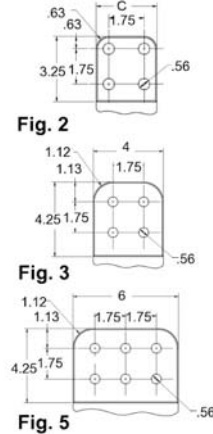
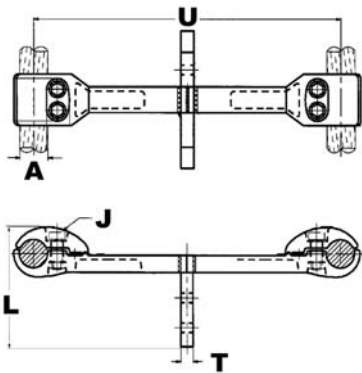

Catalog Number	Aluminum Stranded	Aluminum ACSR	T	J Dia.	U	L
S2GBPA36A8	350 kcmil-600 kcmil	336.4 (30/7) Oriole kcmil- 477 (30/7) Hen kcmil	.81	5/8	8	10.04
S2GBPA445A	1033 kcmil-1113 kcmil	954 (45/7) Rail kcmil- 1033.5 (54/7) Curlew kcmil		5/8	18	20.30
S2GBPA44A	954 kcmil	795 (54/7) Condor kcmil- 874.5 (54/7) Crane kcmil	.38	5/8	18	19.68
S2GBPA44A12	954 kcmil	795 (54/7) Condor kcmil	.81	5/8	12	12.00
S2GBPA44A8	954 kcmil	795 (54/7) Condor kcmil- 874.5 (54/7) Crane kcmil		5/8	8	9.74
S2GBPA45A	1192 kcmil-1272 kcmil	1033.5 (45/7) Ortolan kcmil- 1192.5 (45/7) Bunting kcmil	.50	5/8	18	20.26
S2GBPA45A12	1192 kcmil-1272 kcmil	1033.5 (45/7) Ortolan kcmil- 1192.5 (54/19) Grackle kcmil		5/8	12	14.32
S2GBPA46A12	1590 kcmil-1600 kcmil	1272 (54/19) Pheasant kcmil- 1431 (54/19) Plover kcmil	.38	5/8	12	12.00
S2GBPA46A8	1590 kcmil			5/8	8	10.30
S2GBPA486A12	2300 kcmil-2500 kcmil	2156 (84/19) Bluebird kcmil- 2167 (72/7) Kiwi kcmil	.81	5/8	12	14.56
S2GBPA48A	1750 kcmil-2000 kcmil			5/8	18	20.30
S2GBPA48A10	1750 kcmil-2000 kcmil	1590 (45/7) Lapwing kcmil- 1780 (84/19) Chukar kcmil	.81	5/8	10	12.30
S2GBPA48A12	1750 kcmil-2000 kcmil			5/8	12	14.30
S2GBPA48A8	1750 kcmil-2000 kcmil			5/8	8	10.30

**TYPE S2GBPA-B2
SPACER**

For Use On (2) CABLES TO
TAP PAD



Streamlined rigid spacer for large range of cables with tap pad. Particularly appropriate for 8"+ spacing. 2 bolts per clamping module provides additional clamping strength. Pad requires STS shielding caps for EHV.

EHV RATED: SELF-SHIELDING UP TO 550kV

Material: Aluminum Alloy
Hardware: Aluminum Hardware

Notes :

- Properly proportioned to minimize conductor corrosion due to galvanic action. When properly used, this item does not require use of bimetallic plates. Please ask BURNDY® Technical Support for recommendations
- PENETROX™ A joint compound is recommended on contact surfaces
- Please contact factory for other sizes, combinations and availability
- One-wrench installation

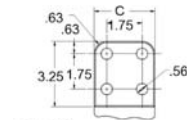
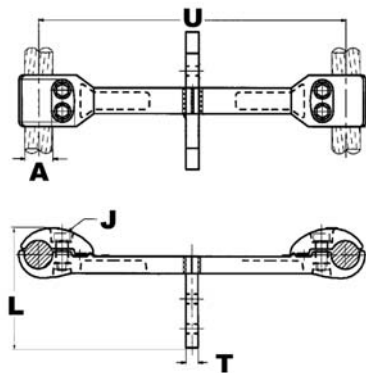

Fig. 2

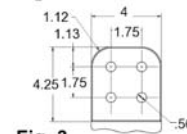

Fig. 3

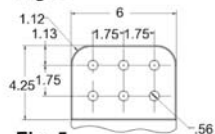
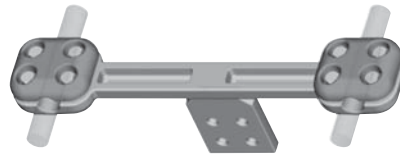

Fig. 5

Catalog Number	Aluminum Stranded	Aluminum ACSR	J Dia.	U	L	T	C
S2GBPA44A12B2	954 kcmil	N/A	5/8	12	13.68	.81	4.00
S2GBPA45A12B2	1192 kcmil- 1272 kcmil	1033.5 (54/7) Curlew kcmil- 1113 (54/19) Finch kcmil		12	13.84	.81	4.00
S2GBPA45AB2	1192 kcmil- 1272 kcmil			18	20.32	.50	4.00
S2GBPA486A12B2	2300 kcmil- 2500 kcmil	2156 (64/119) kcmil- 2312 (76/19) Thrasher kcmil		12	14.52	1.00	4.00
S2GBPA48A12B2	1750 kcmil- 2000 kcmil	2156 (84/19) Bluebird kcmil- 2312 (76/19) Thrasher kcmil		12	14.30	.81	4.00

**TYPE S2GBPA-B4
SPACER**

For Use On (2) CABLES TO
TAP PAD



Streamlined rigid spacer for large range of cables with tap pad. Particularly appropriate for 8"+ spacing. Version with 4 bolts per clamping module - 2 on each side - provide ideal clamping of cable. Pad requires STS shielding caps for EHV. **EHV RATED: SELF-SHIELDING UP TO 550kV**

Material: Aluminum Alloy
Hardware: Aluminum Hardware

Notes :

- Properly proportioned to minimize conductor corrosion due to galvanic action. When properly used, this item does not require use of bimetallic plates. Please ask BURNDY® Technical Support for recommendations
- PENETROX™ A joint compound is recommended on contact surfaces
- Please contact factory for other sizes, combinations and availability
- One-wrench installation.

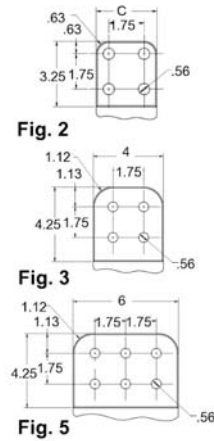
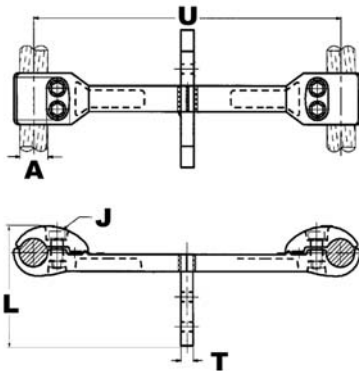

Catalog Number	Aluminum Stranded	Aluminum ACSR	T	J Dia.	U	L	C
S2GBPA41A12B4	795 kcmil-874 kcmil	795 (54/7) Condor kcmil	.44	5/8	12.00	13.42	4.00
S2GBPA445A12B4	1033 kcmil-1113 kcmil	954 (45/7) Rail kcmil-1033.5 (54/7) Curlew kcmil		5/8	12.00	16.62	4.00
S2GBPA445AB4	1033 kcmil-1113 kcmil	954 (45/7) Rail kcmil-1033.5 (45/7) Ortolan kcmil		5/8	18.00	22.60	4.00
S2GBPA44A12B4	954 kcmil	795 (26/7) Drake kcmil-874.5 (54/7) Crane kcmil	.38	5/8	12.00	13.50	4.00
S2GBPA44AB4	954 kcmil	795 (30/19) Mallard kcmil-874.5 (54/7) Crane kcmil		5/8	18.00	19.50	4.00
S2GBPA45A12B4	1192 kcmil-1272 kcmil	1033.5 (45/7) Ortolan kcmil-1192.5 (54/19) Grackle kcmil	.44	5/8	12.00	14.32	4.00
S2GBPA46A12B4	1590 kcmil	1272 (54/19) Pheasant kcmil-1431 (54/19) Plover kcmil	.62	5/8	12.00	13.82	4.00
S2GBPA483A12B4	2000 kcmil-2250 kcmil	2034.5 (72/7) Mockingbird kcmil-2167 (72/7) Kiwi kcmil	.88	5/8	12.00	14.13	4.00
S2GBPA483AB4	2000 kcmil-2250 kcmil	1780 (84/19) Chukar kcmil-2167 (72/7) Kiwi kcmil		5/8	18.00	20.13	4.00
S2GBPA486A12B4	2300 kcmil-2500 kcmil	2156 (64/119) kcmil-2167 (72/7) Kiwi kcmil	1.00	5/8	12.00	14.32	4.00
S2GBPA486AB4	2300 kcmil-2500 kcmil			5/8	18.00	20.30	4.00
S2GBPA48A12B4	1750 kcmil-2000 kcmil	1590 (54/19) Falcon kcmil-1780 (54/19) kcmil	.81	5/8	12.00	14.32	4.00

**TYPE SH2GBP
SPACER**

For Use On (2) CABLES TO
INSULATOR POST

Streamlined rigid spacer for large range of cable with bus support mounting base. Particularly appropriate for 8"+ spacing. 1 bolt per clamping module version.

EHV RATED: SELF-SHIELDING UP TO 550kV

Material: Aluminum Alloy
Hardware: Aluminum Hardware

Notes :

- PENETROX™ A joint compound is recommended on contact surfaces
- Please contact factory for other sizes, combinations and availability.

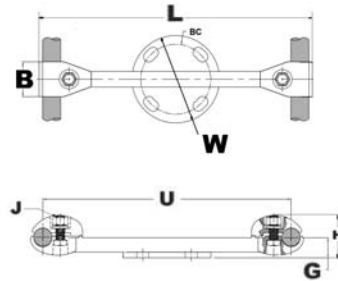
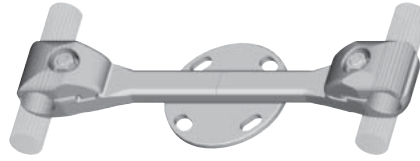

Catalog Number	Aluminum Stranded	Aluminum ACSR	B	J Dia.	U	L	H	BC	G	W
SH2GBP41A5	795 kcmil-874 kcmil	795 (54/7) Condor kcmil	3.00	5/8	18.00	19.71	2.85	5.00	1.50	6.25
SH2GBP41A512	795 kcmil-874 kcmil			5/8	12.00	13.71	2.85	5.00	1.50	6.25
SH2GBP445A512	1033 kcmil-1113 kcmil	954 (45/7) Rail kcmil- 1033.5 (45/7) Ortolan kcmil		5/8	12.00	14.10	2.60	5.00	1.35	6.25
SH2GBP45A5	1192 kcmil-1272 kcmil	1033.5 (54/7) Curlew kcmil-		5/8	18.00	18.00	2.85	5.00	1.50	6.25
SH2GBP45A512	1192 kcmil-1272 kcmil	1192.5 (54/19) Grackle kcmil		5/8	12.00	13.84	2.85	5.00	1.50	6.25
SH2GBP46A5	1590 kcmil-1600 kcmil	1272 (54/19) Pheasant kcmil- 1431 (54/19) Plover kcmil		5/8	18.00	20.30	2.88	5.00	1.50	6.25
SH2GBP46A512	1590 kcmil-1600 kcmil	1272 (54/19) Pheasant- 1431 (54/19) Plover		5/8	12.00	12.00	2.88	5.00	1.50	6.25
SH2GBP486A7	2300 kcmil-2500 kcmil	2167 (72/7) Kiwi- 2156 (84/19) Bluebird		5/8	18.00	20.30	2.56	7.00	1.50	8.50
SH2GBP48A5	1750 kcmil-2000 kcmil	1590 (45/7) Lapwing kcmil- 1780 (84/19) Chukar kcmil		5/8	18.00	18.00	2.56	5.00	1.50	6.25
SH2GBP48A512	1750 kcmil-2000 kcmil	1590 (45/7) Lapwing kcmil- 1780 (54/19) kcmil		5/8	12.00	14.30	2.56	5.00	1.50	6.25
SH2GBP48A7	1750 kcmil-2000 kcmil	1590 (45/7) Lapwing kcmil- 1780 (84/19) Chukar kcmil		5/8	18.00	20.30	2.56	7.00	1.50	8.50
SH2GBP495A58	3500 kcmil	N/A		3/4	8.00	10.70	3.85	5.00	2.00	6.25

**TYPE SH2GBP-B2
SPACER**

For Use On (2) CABLES TO
INSULATOR POST

Streamlined rigid spacer for large range of cable with bus support mounting base. Particularly appropriate for 8"+ spacing. 2 bolts per clamping module version provide additional clamping strength.

EHV RATED: SELF-SHIELDING UP TO 550kV

Material: Aluminum Alloy
Hardware: Aluminum Hardware

Notes :

- PENETROX™ A joint compound is recommended on contact surfaces
- Please contact factory for other sizes, combinations and availability.

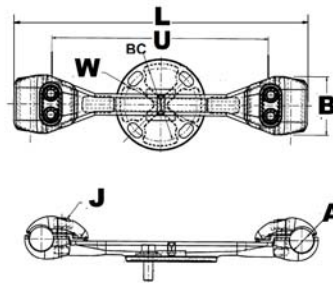
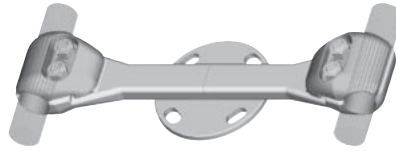

Catalog Number	Aluminum Stranded	Aluminum ACSR	J Dia.	U	L	BC	W
SH2GBP41A512B2	795-874.5	715.5 (24/7) Stilt	5/8	12.00	15.00	5.00	6.25
SH2GBP41A712B2	795 kcmil-874 kcmil	715.5 (24/7) Stilt kcmil		12.00	13.54	7.00	8.50
SH2GBP445A512B2	795 kcmil-874 kcmil			12.00	14.10	5.00	6.25
SH2GBP44A512B2	954 kcmil	795 (54/7) Condor kcmil		12.00	14.30	5.00	6.25
SH2GBP45A512B2	1192 kcmil-1272 kcmil	1033.5 (54/7) Curlew kcmil- 1192.5 (54/19) Grackle kcmil		12.00	14.30	5.00	6.25
SH2GBP486A5B2	2300-2500	2167 (72/7) Kiwi- 2156 (84/19) Bluebird		18.00	14.30	5.00	6.25
SH2GBP48A512B2	1700 kcmil-2000 kcmil	1590 (45/7) Lapwing kcmil- 1780 (84/19) Chukar kcmil		12.00	14.30	5.00	6.25
SH2GBP48A5B2	1750 kcmil-2000 kcmil			18.00	14.30	5.00	6.25
SH2GBP48A712B2	1750 kcmil-2000 kcmil			12.00	14.30	7.00	8.50
SH2GBP48A7B2	1750 kcmil-2000 kcmil			18.00	20.30	7.00	4.00

**TYPE SH2GBP-B4
SPACER**

For Use On (2) CABLES TO
INSULATOR POST

Streamlined rigid spacer for large range of cables with bus support mounting base. Particularly appropriate for 8"+ spacing. Version with 4 bolts per clamping module - 2 on each side - for ideal clamping of the cable.

Material: Aluminum Alloy
Hardware: Aluminum Hardware

Notes :

- PENETROX™ A joint compound is recommended on contact surfaces
- Please contact factory for other sizes, combinations and availability.

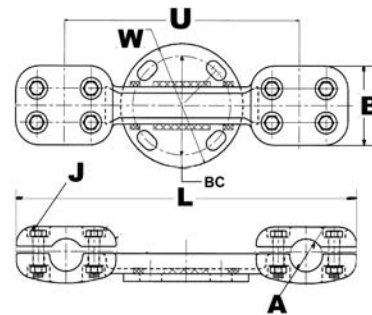
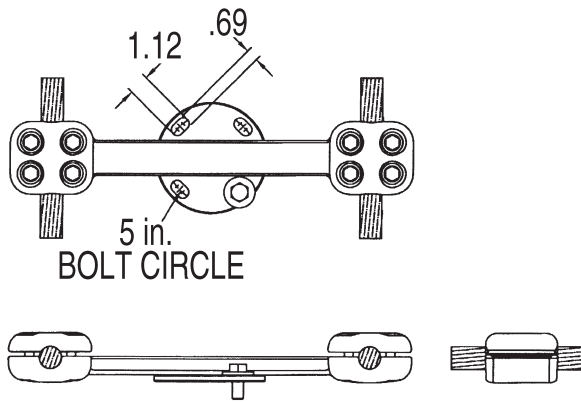

Catalog Number	Aluminum Stranded	Aluminum ACSR	B	J Dia.	U	L	BC	W
SH2GBP445A515B4	1033.5 kcmil-1113 kcmil	954 (45/7) Rail-1033.5 (45/7) Ortolan	4.00	1/2	15.00	19.60	5.00	6.25
SH2GBP44A512B4	954 kcmil	795 (54/7) Condor kcmil-874.5 (54/7) Crane kcmil		1/2	12.00	14.30	5.00	6.25
SH2GBP486A512B4	2300 kcmil-2500 kcmil	2167 (72/7) Kiwi-2156 (84/19) Bluebird		1/2	12.00	15.00	5.00	6.25
SH2GBP486A5B4	2300 kcmil-2500 kcmil	2156 (84/19) Bluebird kcmil-2167 (72/7) Kiwi kcmil		1/2	18.00	20.30	5.00	6.25
SH2GBP48A512B4	1750 kcmil-2000 kcmil	1590 (45/7) Lapwing kcmil-1780 (84/19) Chukar kcmil		1/2	12.00	14.30	5.00	6.25
SH2GBP48A5B4	1750 kcmil-2000 kcmil	1590 (45/7) Lapwing kcmil-1780 (84/19) Chukar kcmil	5.00	1/2	18.00	23.00	5.00	6.25

**TYPE CP3R
SPACER**

For Use On (3) CABLE
SPACER

Rigid spacer for 3 cables flat.
Particularly appropriate design for
short spacing.

Material: Aluminum Alloy
Hardware: Aluminum Hardware

Notes :

- PENETROX™ A joint compound is recommended on contact surfaces
- Please contact factory for other sizes, combinations and availability.

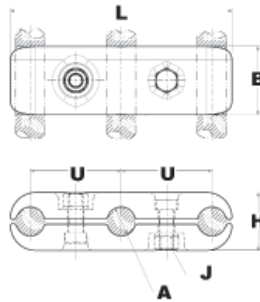

Catalog Number	Aluminum Stranded	Aluminum ACSR	B	J Dia.	U	L	H
CP3R445A4	1000 kcmil- 1113 kcmil	900 (54/7) Canary kcmil- 1033.5 (45/7) Ortolan kcmil	3.00	5/8	4.00	9.76	2.54

**TYPE S3GBP
SPACER**

For Use On (3) CABLE RIGID
SPACER

Streamlined rigid spacer for 3 cables
in triangular shapes. Particularly
appropriate for 8"+ spacing. 1 bolt per
clamping module version.

**EHV RATED: SELF-SHIELDING UP
TO 550kV**

Material: Aluminum Alloy
Hardware: Aluminum Hardware

Notes :

- PENETROX™ A joint compound is recommended on contact surfaces
- Please contact factory for other sizes, combinations and availability.

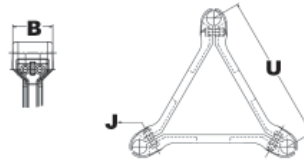

Catalog Number	Aluminum Stranded	Aluminum ACSR	B	J Dia.	U
S3GBP41A	795 kcmil-874 kcmil	715.5 (24/7) Stilt kcmil- 715.5 (26/7) Starling kcmil	3.00	5/8	18.00
S3GBP445A	1033 kcmil-1113 kcmil	954 (45/7) Rail kcmil- 1033.5 (45/7) Ortolan kcmil		4.00	5/8
S3GBP445AB2	1033 kcmil-1113 kcmil				5/8
S3GBP44A	954 kcmil	795 (54/7) Condor kcmil- 795 (26/7) Drake kcmil	3.00	5/8	18.00
S3GBP45A	1192 kcmil-1272 kcmil	1033.5 (54/7) Curlew kcmil- 1192.5 (54/19) Grackle kcmil		5/8	18.00
S3GBP46A	1590 kcmil-1600 kcmil	1272 (54/19) Pheasant kcmil- 1431 (54/19) Plover kcmil		5/8	18.00
S3GBP483A	2000 kcmil-2250 kcmil	1780 (84/19) Chukar kcmil- 2167 (72/7) Kiwi kcmil		5/8	18.00
S3GBP486A	2300 kcmil-2500 kcmil	2156 (64/119) kcmil- 2167 (72/7) Kiwi kcmil		5/8	18.00
S3GBP486A8	2300 kcmil-2500 kcmil			5/8	8.00
S3GBP48A	1750 kcmil-2000 kcmil	1590 (45/7) Lapwing kcmil- 1780 (54/19) Chukar kcmil	4.00	5/8	18.00
S3GBP48AB2	1750 kcmil-2000 kcmil			5/8	18.00

**TYPE S3GBPA
SPACER**

For Use On (3) CABLES TO
TAP PAD

Streamlined rigid spacer for 3
cables in triangular shapes with
tap pad. Particularly appropriate for
8"+ spacing. 2 bolts per clamping
module version for additional clamping
strength.

**EHV RATED: SELF-SHIELDING UP
TO 550kV**

Material: Aluminum Alloy
Hardware: Aluminum Hardware

Notes :

- PENETROX™ A joint compound is recommended on contact surfaces
- Please contact factory for other sizes, combinations and availability.

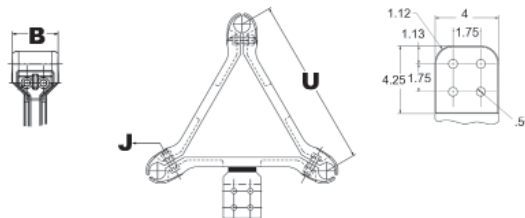

Catalog Number	Aluminum Stranded	Aluminum ACSR	B	J Dia.	U
S3GBPA445A	1033 kcmil-1113 kcmil	954 (45/7) Rail kcmil- 1033.5 (54/7) Curlew kcmil	3.00	5/8	18.00
S3GBPA44A	954 kcmil	795 (54/7) Condor kcmil- 795 (26/7) Drake kcmil		5/8	18.00
S3GBPA45A	1192 kcmil-1272 kcmil	1033.5 (54/7) Curlew kcmil- 1192.5 (54/19) Grackle kcmil		5/8	18.00
S3GBPA48A	1750 kcmil-2000 kcmil	1590 (45/7) Lapwing kcmil- 1780 (84/19) Chukar kcmil		5/8	18.00

**TYPE S3GBP2
SPACER**

For Use On (3) CABLES RIGID
SPACER

Streamlined rigid spacer for 3
cables bundles in triangular shapes.
Particularly appropriate for 8"+
spacing. 2 bolts per clamping module
version for additional clamping
strength.

**EHV RATED: SELF-SHIELDING UP
TO 550kV**

Material: Aluminum Alloy
Hardware: Aluminum Hardware

Notes :

- PENETROX™ A joint compound is recommended on contact surfaces
- Please contact factory for other sizes, combinations and availability.

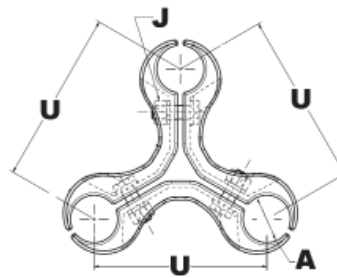
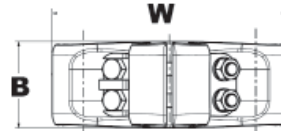

Catalog Number	Aluminum Stranded	B	J Dia.	U	W
S3GBP495A8B2	3500 kcmil	4.00	5/8	8.00	10.85

**TYPE SH3GBP
SPACER**

For Use On (3) CABLES TO
INSULATOR POST

Streamlined rigid spacer for 3
cables in triangular shapes with bus
support mounting base. Particularly
appropriate for 8"+ spacing. 2 bolts
per clamping module version for
additional clamping strength.

**EHV RATED: SELF-SHIELDING UP
TO 550kV**

Material: Aluminum Alloy
Hardware: Aluminum Hardware

Notes :

- PENETROX™ A joint compound is recommended on contact surfaces
- Please contact factory for other sizes, combinations and availability
- Suffix "-B2" is used for 2 bolt clamping module; "-B4" for 4 bolt clamping module

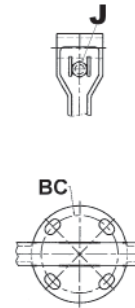
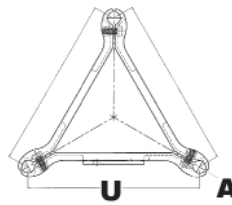

Catalog Number	Aluminum Stranded	Aluminum ACSR	BC	J Dia.	U
SH3GBP445A5B2	1113 kcmil	954 (45/7) Rail kcmil- 1033.5 (45/7) Ortolan kcmil	5.00	5/8	18.00
SH3GBP44A5	954 kcmil	795 (54/7) Condor kcmil- 795 (26/7) Drake kcmil		5/8	18.00
SH3GBP45A5	900 kcmil-1250 kcmil	715.5 (30/19) Redwing kcmil- 1113 (54/19) Finch kcmil		5/8	18.00
SH3GBP45A5B2	900 kcmil-1250 kcmil			5/8	18.00
SH3GBP46A5	1590 kcmil	1272 (54/19) Pheasant kcmil- 1431 (54/19) Plover kcmil		5/8	18.00
SH3GBP48A5	1750 kcmil-2000 kcmil	1590 (45/7) Lapwing kcmil- 1780 (54/19) kcmil		5/8	18.00
SH3GBP48A5B2	1750 kcmil-2000 kcmil			5/8	18.00

**TYPE S3GGBP
SPACER**

For Use On (3) CABLE RIGID
SPACER WITH GROUNDING
ROD

Streamlined rigid spacer for 3 cables
in triangular shapes. The rod joining
both cable module is circular to
accommodate grounding clamps.

**EHV RATED: SELF-SHIELDING UP
TO 550kV**

Material: Aluminum Alloy

Hardware: Aluminum Hardware

Notes :

- PENETROX™ A joint compound is recommended on contact surfaces
- Please contact factory for other sizes, combinations and availability.

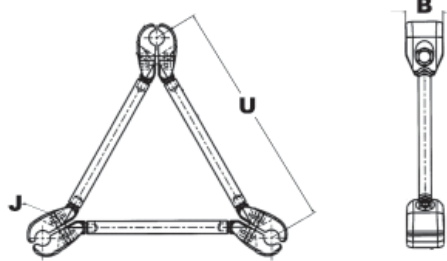

Catalog Number	Aluminum Stranded	Aluminum ACSR	B	J Dia.	U
S3GGBP445A	1033 kcmil-1113 kcmil	954 (45/7) Rail kcmil- 1033.5 (45/7) Ortolan kcmil	3.00	5/8	18.00

**TYPE S4GBP
SPACER**

For Use On (4) CABLE RIGID
SPACER

Streamlined rigid spacer for 4 cables.
1, 2 or 4 bolt design.
**EHV RATED: SELF-SHIELDING UP
TO 550kV**

Material: Aluminum Alloy
Hardware: Aluminum Hardware

Notes :

- One wrench installation
- PENETROX™ A joint compound is recommended on contact surfaces
- Please contact factory for other sizes, combinations and availability.

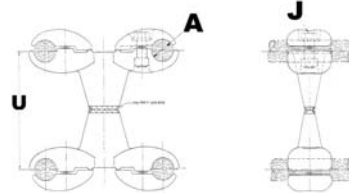

Catalog Number	Aluminum Stranded	Aluminum ACSR	J Dia.	U
S4GBP48A	1750 kcmil-2000 kcmil	1590 (45/7) Lapwing kcmil- 1780 (84/19) Chukar kcmil	5/8	18.00
S4GBP48A12	1750 kcmil-2000 kcmil	1590 (54/19) Falcon kcmil- 1780 (84/19) Chukar kcmil		12.00

**TYPE SH4GBP
SPACER**

For Use On (4) CABLES TO
INSULATOR POST

Streamlined rigid spacer for 4 cables
with bus support mounting base. 1, 2
or 4 bolt design.

**EHV RATED: SELF-SHIELDING UP
TO 550kV**

Material: Aluminum Alloy
Hardware: Aluminum Hardware

Notes :

- One wrench installation
- PENETROX™ A joint compound is recommended on contact surfaces
- Please contact factory for other sizes, combinations and availability.

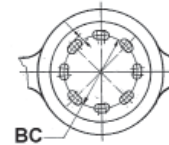
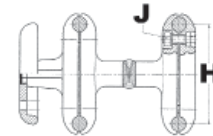
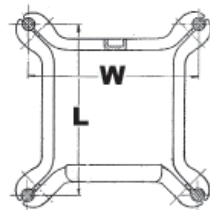

Catalog Number	Aluminum Stranded	Aluminum ACSR	BC	J Dia.	L	H
SH4GBP48A5	2000 kcmil	N/A	5.00	5/8	16.00	16.00

Table of Contents - Aluminum Shielding Caps/End Bells



Type STS Terminal Pad Shielding Cap A-159



Type STS-CG Terminal Pad Shielding Cap A-160



Type LB-A Pipe End Cap A-161



Type CB-A Pipe End Cap A-163



Type SCB Corona Pipe End Cap A-164



Type SCBB Corona Pipe End Cap (Set Screw) A-165



Type SR Corona Shielding Ring A-166

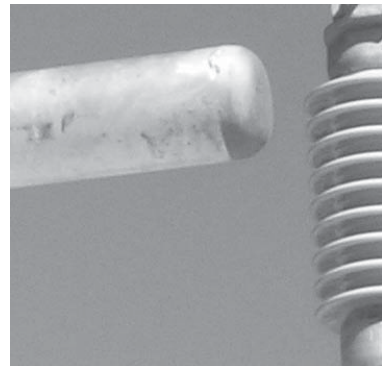

**TYPE STS
STREAMLINED PAD
CAPS**

For Use On PAD ASSEMBLIES
SHIELDING

Streamlined caps for shielding hardware when bolting terminals to flat pads singly or back to back. Caps are for 4 NEMA tongues. Adapter is attached with tongue hardware. Shielding cap is fastened to adapter with stainless steel cap screw. Order one (1) STS for each side of pad.
EHV RATED: SELF-SHIELDING UP TO 550kV

Material: Aluminum Alloy
Hardware: Aluminum Hardware

Notes :

- PENETROX™ A joint compound is recommended on contact surfaces
- Please contact factory for other sizes, combinations and availability.

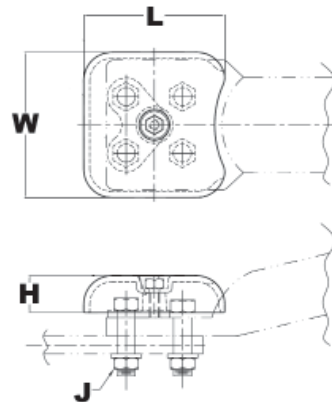

Catalog Number	J Dia.	L	H	W
STS33A-4N	1/2	3.48	1.25	3.62
STS43A-4N	1/2	3.36	1.31	4.50
STS44A-4N	1/2	4.50	1.25	4.62

**TYPE STS-CG
TERMINAL PAD CAP
(One Piece)**

For Use On PAD ASSEMBLIES
SHIELDING



**EHV RATED: SELF-SHIELDING UP
TO 550 kV**

Material: Cast 356 Aluminum Alloy

Material: Aluminum Alloy

Hardware: Aluminum Hardware

Notes :

- PENETROX™ A joint compound is recommended on contact surfaces
- Please contact factory for other sizes, combinations and availability.

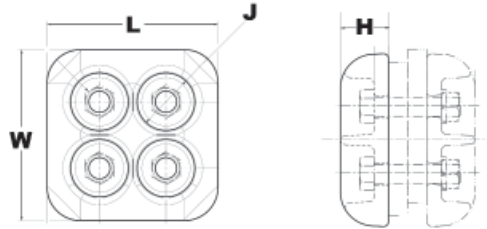

Catalog Number	J - Dia.	L	H	W
STS33A4NCG1	1/2	3.52	1.50	3.52
STS44A4NCG1	1/2	4.52	1.25	4.52
STS44A-4NCG2	1/2	4.50	1.25	4.50
STS44ACG10	1/2	4.00	1.50	4.00
STS44ACG7	1/2		1.12	4.00
STS46A6NCG1	1/2	6.50	1.12	4.50

**TYPE LB-A
END CAP**

For Use On PIPE END CAP

Aluminum alloy end cap for aluminum tube. Driven into place for a secure fit. Seals out moisture, reduces electrostatic loss and eliminates hazards created by nesting birds.

Material: Aluminum Alloy
Hardware: Aluminum Hardware

Notes :

- Installation instructions available upon request
- Please contact factory for other sizes, combinations and availability.

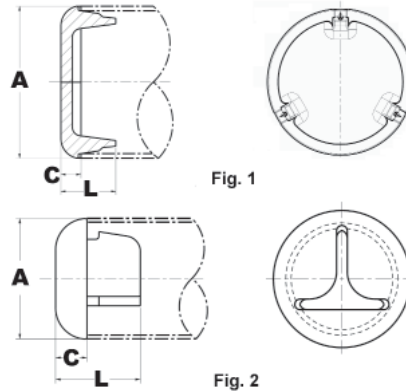

Catalog Number	Al tube Sch 40	Al tube Sch 80	C	L
LB13A	1/2 IPS	N/A	.38	1.25
LB14A	3/4 IPS		.50	1.37
LB15A	1 IPS		.50	1.35
LB16A	1 1/4 IPS		.50	1.35
LB17A	1 1/2 IPS		.50	1.35
LB18A	2 IPS		.88	2.16
LB19A	2 1/2 IPS		.88	2.24
LB20A	3 IPS		.88	2.29
LB21A	3 1/2 IPS		.88	2.33
LB22A	4 IPS		.88	2.22
LB23A	4 1/2 IPS		.88	2.28
LB24A	5 IPS		.88	2.45
LB83A	8 OD		.75	2.28
LB86A	6 IPS		.88	2.57
LB88A	8 IPS		.75	2.28
LB53A	N/A		1/2 IPS	.38
LB54A		3/4 IPS	.50	1.37
LB55A		1 IPS	.50	1.35
LB56A		1 1/4 IPS	.50	1.35
LB57A		1 1/2 IPS	.50	1.35
LB58A		2 IPS	.88	2.16
LB59A		2 1/2 IPS	.88	2.24

TYPE LB-A
END CAP (Continued)

For Use On PIPE END CAP



Catalog Number	Al tube Sch 40	Al tube Sch 80	C	L
LB90A	N/A	3 IPS	.88	2.29
LB91A		3 1/2 IPS	.88	2.33
LB92A		4 IPS	.88	2.22
LB94A		5 IPS	.88	2.45
LB96A		6 IPS	.88	2.57

**TYPE CB-A
END CAP**

For Use On ALUMINUM PIPE

Aluminum alloy end cap for aluminum tube. Seals out moisture, reduces electrostatic loss and eliminates hazards created by nesting birds.

Material: Aluminum Alloy
Hardware: Aluminum Hardware

Notes :

- Installation instructions available upon request
- Please contact factory for other sizes, combinations and availability.

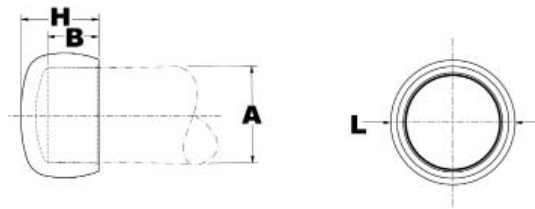

Catalog Number	Al tube	B	L	H
CB15A	1 IPS	0.94	1.59	2.31
CB16A	1 1/4 IPS	1.12	1.91	2.50
CB17A	1 1/2 IPS	1.31	2.06	2.81
CB18A	2 IPS	1.50	2.31	3.38
CB19A	2 1/2 IPS	1.62	2.38	3.81
CB20A	3 IPS	1.83	2.84	4.56
CB21A	3 1/2 IPS	2.00	2.84	4.56
CB22A	4 IPS	2.12	3.13	5.74
CB24A	5 IPS	2.38	3.46	6.98
CB86A	6 IPS	2.75	4.40	8.20

**TYPE SCB
WELDED CORONA BELL**

For Use On CORONA BELL
WELDED



Aluminum Alloy streamlined, self-shielding corona end bells operate at voltages up to 550kV. For standard (Schedule 40) and extra heavy (Schedule 80) tube.

Material: Aluminum Alloy
Hardware: Aluminum Hardware

Notes :

- Welding to be done by customer
- Please contact factory for other sizes, combinations and availability.

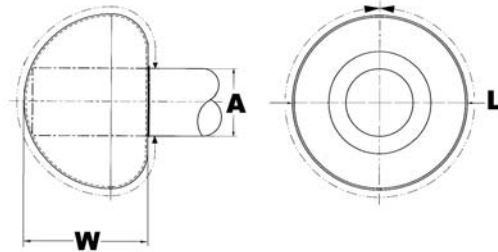

Catalog Number	Al tube (Sch 40 & 80)	W	L
SCB18A	2 IPS	12.00	8.5
SCB19A	2 1/2 IPS		8.5
SCB20A	3 IPS		8.5
SCB21A	3 1/2 IPS		8.5
SCB22A	4 IPS		8.5
SCB24A	5 IPS		8.5
SCB83A	8 OD		8.5
SCB86A	6 IPS		8.5

**TYPE SCBB
END CAP**

For Use On CORONA BELL
(SET SCREW)

Aluminum Alloy streamlined, self-shielding corona end bells operate at voltages up to 550kV. For standard (Schedule 40) and extra heavy (Schedule 80) tube. Bus to Corona Bell connector with set screws for alignment.

Material: Aluminum Alloy
Hardware: Aluminum Hardware

Notes :

- Welding to be done by customer
- Please contact factory for other sizes, combinations and availability.

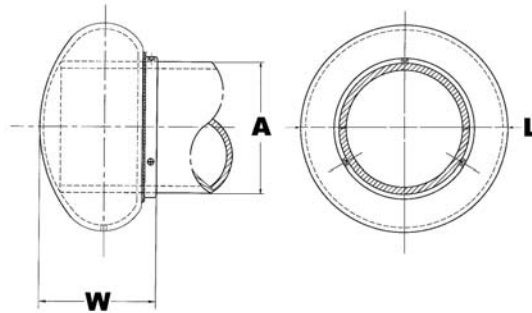

Catalog Number	Al tube (Sch 40 & 80)	W	L
SCBB20A	3 IPS	12.00	9.25
SCBB21A	3 1/2 IPS		9.25
SCBB24A	5 IPS		9.25
SCBB86A	6 IPS		9.25
SCBB88A	8 IPS		9.25

**TYPE SR
CORONA RING**

For Use On EHV Connectors

Corona Ring is assembled with connectors to operate at EHV.
EHV RATED: SELF-SHIELDING UP TO 550 kV.



Material: Aluminum Alloy
Hardware: Aluminum Hardware

Notes :

- Installation instructions available upon request
- Contact factory for bracket configurations and additional dimensions.
- Bracket configurations can be made to order.

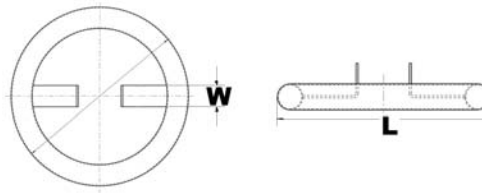

Catalog Number	W	L
SR701826	5.48	18.00
SR701830	5.38	
SR70201	3.00	20.00
SR70203	5.38	
SR70204	5.38	
SR70253	4.44	25.00
SR70254	3.00	
SR70256	6.00	
SR702561	3.00	
SR702562	4.00	
SR702563	3.00	
SR702564	3.00	
SR702565	10.00	
SR702566	5.38	
SR702567	3.00	
SR702568	5.50	
SR702569	4.50	
SR705321HQ	3.00	
SR705322HQ	3.00	

Table of Contents - Aluminum Bolted Grounding Studs

	Type NG Pipe to Ground Stud	A-169
	Type NTB Pipe or Cable Grounding Stirrup	A-170
	Type SNCB Pipe to Grounding Stud with Corona Ball	A-171
	Type SNG Pipe to Ground Stud	A-172
	Type SN2GB Cable Spacer Ground Stirrup	A-173
	Type S2GGBP Cable Spacer Ground Stirrup	A-174
	Type S3GGBP Cable Spacer Ground Stirrup	A-175

**TYPE NG
GROUND CONNECTOR**

For Use On PIPE TO GROUND
STUD

Aluminum alloy grounding stud
connector.

Material: Aluminum Alloy
Hardware: Aluminum Hardware

Notes :

- PENETROX™ A joint compound is recommended on contact surfaces
- Please contact factory for other sizes, combinations and availability

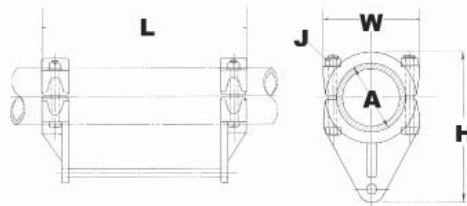

Catalog Number	Al tube	J Dia.	L	H	W
NG19ACG2	2 1/2 IPS	1/2	16.00	8.64	4.62
NG21ACG1	3 1/2 IPS		18.00	9.76	5.75
NG24ACG1	5 IPS		18.00	11.38	7.31

**TYPE NTB
GROUND STIRRUP**

For Use On ALUMINUM PIPE
GROUND STIRRUP

Aluminum alloy grounding stud
connector.

Material: Aluminum Alloy
Hardware: Aluminum Hardware

Notes :

- PENETROX™ A joint compound is recommended on contact surfaces
- One-wrench installation.
- Please contact factory for other sizes, combinations and availability.

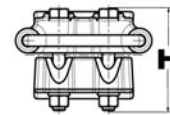
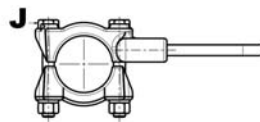
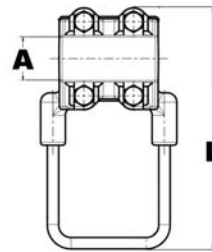

Catalog Number	Al tube	J Dia.	L	H
NTB17AG1	1 1/2 IPS	1/2	8.32	3.88
NTB18AG1	2 IPS		8.94	4.31
NTB19AG1	2 1/2 IPS		9.44	4.34
NTB20AG1	3 IPS		10.06	4.97
NTB22AG1	4 IPS		11.15	5.75
NTB24AG1	5 IPS		12.12	6.91
NTB86AG1	6 IPS		13.31	8.00

**TYPE SNCB
STUD CONNECTOR**

For Use On TUBE TO STUD

Aluminum alloy streamlined grounding stud connector.

Material: Aluminum Alloy
Hardware: Aluminum Hardware

Notes :

- PENETROX™ A joint compound is recommended on contact surfaces
- One-wrench installation.
- Please contact factory for other sizes, combinations and availability

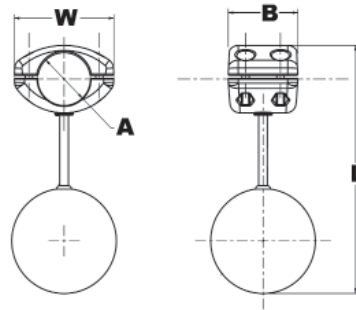

Catalog Number	Al tube	L	B	W
SNCB20A	3 IPS	18.05	5.00	7.56
SNCB22A	4 IPS	19.05	6.00	8.56
SNCB24A	5 IPS	20.25	7.00	9.68
SNCB86A	6 IPS	21.32	8.00	10.74

**TYPE SNG
BOLTED GROUND
STIRRUP**

For Use On PIPE TO STUD

Aluminum alloy streamlined grounding stud connector.

Material: Aluminum Alloy
Hardware: Aluminum Hardware

Notes :

- PENETROX™ A joint compound is recommended on contact surfaces
- One-wrench installation.
- Please contact factory for other sizes, combinations and availability

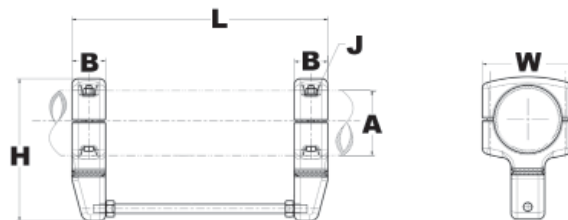
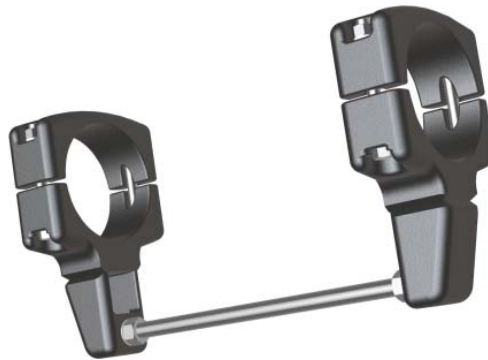

Catalog Number	Al tube	W	H	B	J Dia.	L
SNG21ACG1	3 1/2 IPS	5.86	10.63	2.75	1/2	20.98

**TYPE SN2GB
CABLE GROUND
STIRRUP**

For Use On (2) CABLE
GROUND STIRRUP

Aluminum alloy streamlined grounding
stirrup. Operating voltage 500kV.

Material: Aluminum Alloy
Hardware: Aluminum Hardware

Notes :

- PENETROX™ A joint compound is recommended on contact surfaces
- Please contact factory for other sizes, combinations and availability.

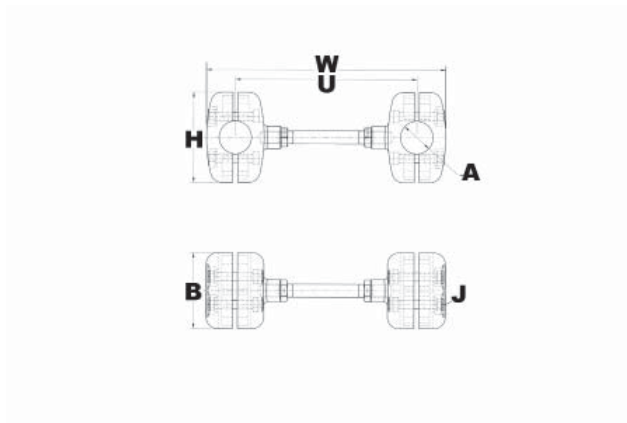

Catalog Number	B	J Dia.	W	H	U
SN2GB486ACG1	5.38 in	1/2 in	13.00 in	6.00 in	13 in
SN2GB495A12SSDN	7.25 in	1/2 in	12.00 in	6.56 in	12 in
SN2GB495ASSDN	7.25 in	1/2 in	18.00 in	6.56 in	18 in
SN2GB496A15HQ	8.00 in	5/8 in	15.00 in	4.62 in	15 in
SN2GB496ACG1	5.88 in	5/8 in	13.00 in	7.00 in	13 in

**TYPE S2GGBP
SPACER**

For Use On (2) CABLE RIGID
SPACER WITH GROUNDING
ROD

Streamlined rigid spacer for large
range of cables. The rod joining
both cable modules is circular to
accommodate grounding clamps.

**EHV RATED: SELF-SHIELDING UP
TO 550kV**

Material: Aluminum Alloy

Hardware: Aluminum Hardware

Notes :

- PENETROX™ A joint compound is recommended on contact surfaces
- One wrench installation
- Please contact factory for other sizes, combinations and availability
- 1, 2 or 4 bolt designs available.

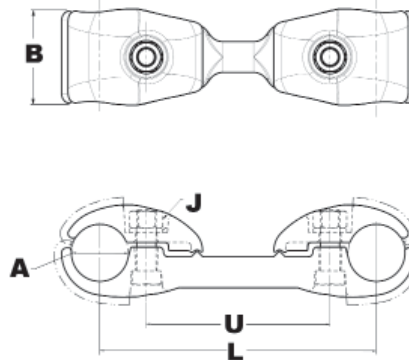

Catalog Number	Aluminum Stranded	Aluminum ACSR	B	J Dia.	U	L
S2GGBP445A12	954 kcmil- 1033 kcmil	795 (54/7) Condor kcmil- 954 (45/7) Rail kcmil	4.00	1/2	12.00	14.04
S2GGBP486A	2300 kcmil- 2500 kcmil	2156 (84/19) Bluebird kcmil- 2167 (72/7) Kiwi kcmil	3.00	5/8	18.00	20.76
S2GGBP486A9	2300 kcmil- 2500 kcmil		3.12	5/8	9.00	11.50
S2GGBP48A	1750 kcmil- 2000 kcmil	1590 (45/7) Lapwing kcmil- 1780 (54/19) kcmil	3.00	5/8	18.00	20.76
S2GGBP48A12	1750 kcmil- 2000 kcmil	1590 (54/19) Falcon kcmil- 1780 (84/19) Chukar kcmil		5/8	12.00	14.76

**TYPE S3GGBP
SPACER**

For Use On (3) CABLE RIGID
SPACER WITH GROUNDING
ROD

Streamlined rigid spacer for 3 cables
in triangular shapes. The rod joining
both cable module is circular to
accommodate grounding clamps.

**EHV RATED: SELF-SHIELDING UP
TO 550kV**

Material: Aluminum Alloy
Hardware: Aluminum Hardware

Notes :

- PENETROX™ A joint compound is recommended on contact surfaces
- Please contact factory for other sizes, combinations and availability.

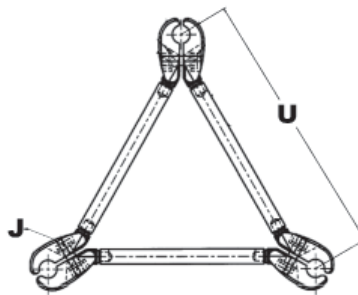

Catalog Number	Aluminum Stranded	Aluminum ACSR	B	J Dia.	U
S3GGBP445A	1033 kcmil-1113 kcmil	954 (45/7) Rail kcmil-1033.5 (45/7) Ortolan kcmil	3.00	5/8	18.00

Table of Contents - Aluminum Welded Terminals

	Type WA-R-N Cable to Pad	A-179
	Type W2A-A-N 2 Cables to Pad	A-181
	Type W3A 3 Cables to Flat	A-183
	Type WA-A-N Pipe to Pad	A-184
	Type WA-A-N90 Pipe to Angle Pad	A-185
	Type WAS-A Pipe to Pad	A-186
	Type WASC Pipe to Center Form Pad	A-187
	Type WXA Expansion Pipe to Flat (With Guide)	A-188
	Type WXA-NR90 Expansion Pipe to Flat (With Guide)	A-190
	Type WXOA Expansion Pipe to Offset Pad	A-191
	Type SWAR Cable to Pad	A-192
	Type SWAR90 Cable to Angle Pad	A-193
	Type SW2A 2 Cables to Pad	A-194
	Type SW2A90 2 Cables to Angle Pad	A-195

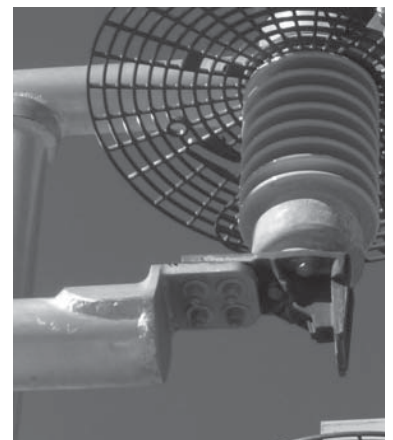
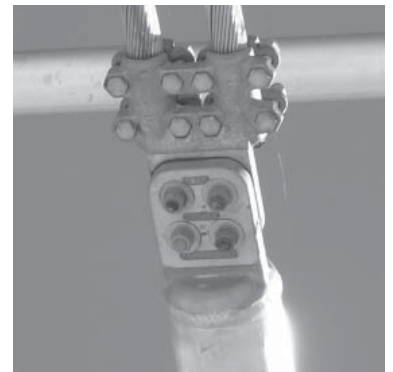
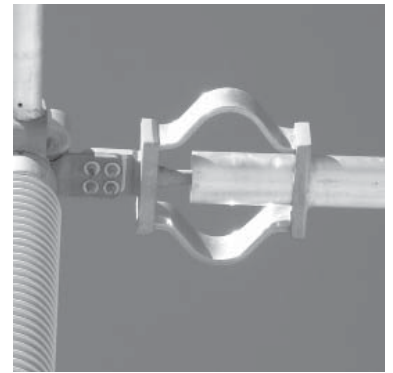
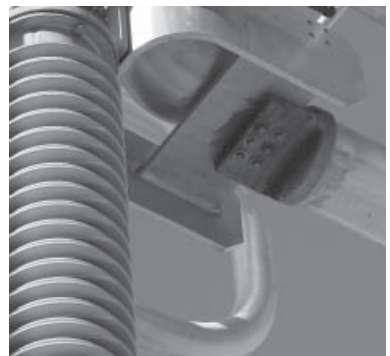

Table of Contents - Aluminum Welded Terminals (continued)

	Type SW3A 3 Cables to Pad	A-196
	Type SWA Pipe to Flat	A-197
	Type SWA90 Pipe to Angle Pad	A-198
	Type SWAC Pipe to Pad	A-199
	Type SWACC Pipe to Pad	A-201
	Type SW3AN8 Pipe to 3 Pads	A-202
	Type SW2AG3 Pipe to 2 or 4 Pads	A-203
	Type SWXA-K8 Expansion Pipe to Pad	A-204
	Type SWXA-90K Expansion Pipe to Pad	A-205
	Type SWXA Expansion Pipe to Pad	A-206
	Type SWXA-A-NR90	A-207
	Type YNA-R	A-208



**TYPE WA-R-N
WELDED TERMINAL
CONNECTOR**

For Use On CABLE TO PAD

High aluminum alloy terminal for joining a range of aluminum cable to pad.

Material: Aluminum Alloy



Notes :

- Welding to be done by customer
- Before welding scratch brush connector and conductor contact surface dry, then apply an oxide inhibitor.
- Tongue finished on one side only. For tongue finished on both sides, add suffix “-Q” to catalog number.

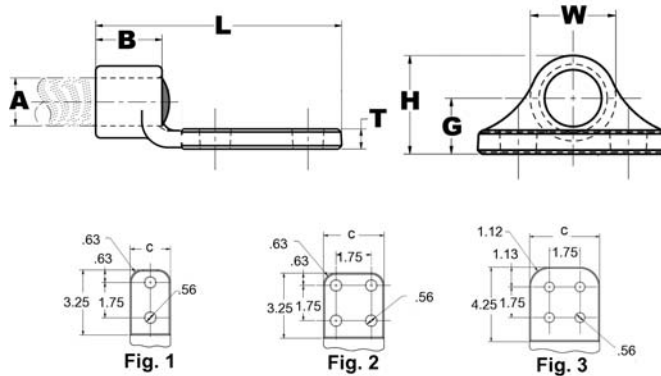

Catalog Number	Fig. #	A-Aluminum Stranded	A-Aluminum ACSR	C	B	L	H	T	W
WA25R2N	1	1 AWG-1/0 AWG	1 (6/1) Robin AWG-1/0 (6/1) Raven AWG	1.25	.75	4.12	1.02	5/16	.83
WA28R2N	1	4/0 AWG-250 kcmil	4/0 (6/1) Penquin AWG-134.6 (12/7) Leghorn kcmil	1.25	1.00	4.25	1.81	5/16	1.01
WA30R2N	1	250 kcmil-312.8 kcmil	159 (12/7) Guinea kcmil-266.8 (18/1) Waxwing kcmil	1.02	1.00	5.00	1.35	3/8	1.09
WA30R4N	2	250 kcmil-312.8 kcmil	159 (12/7) Guinea kcmil-266.8 (18/1) Waxwing kcmil	3.00	1.00	5.00	1.35	3/8	1.09
WA341R2N	1	336 kcmil-400 kcmil	211.3 (12/7) Cochin kcmil-397.5 (26/7) Ibis kcmil	1.25	1.25	4.50	1.81	1/2	1.21
WA341R4N	2			3.00	1.25	4.50	1.81	1/2	1.21
WA361R2N	1	428 kcmil-500 kcmil	397.5 (18/1) Chickadee kcmil-477.0 (18/1) Pelican kcmil	1.59	1.25	4.62	1.57	3/8	1.36
WA361R4N	2			3.00	1.25	4.62	1.57	3/8	1.36
WA41R2N	1	500 kcmil-650 kcmil	477.0 (18/1) Pelican kcmil-605 (24/7) Peacock kcmil	2.00	1.50	4.75	1.88	1/2	1.53
WA41R4N	2			3.00	1.50	4.75	1.88	1/2	1.53
WA444A44N	3	900 kcmil-1100 kcmil	795 (54/7) Condor kcmil-954 (54/7) Cardinal kcmil	4.00	1.75	6.25	2.19	1/2	1.96
WA444A4N	2			3.00	1.75	5.00	2.19	1/2	1.96
WA44R2N	1	700 kcmil-874.5 kcmil	605 (24/7) Peacock kcmil-715.5 (54/7) Crow kcmil	2.62	1.50	5.00	2.00	1/2	1.75
WA44R4N	2			3.00	1.50	5.00	2.00	1/2	1.75
WA454A4N	2	1113 kcmil-1351.5 kcmil	1033.5 (54/7) Curlew kcmil-1192.5 (45/7) Bunting kcmil	3.00	2.00	5.19	2.31	1/2	2.13
WA486A4N	2	2300 kcmil-2500 kcmil	2156 (64/119) kcmil-2312 (76/19) Thrasher kcmil	3.00	2.62	6.00	3.32	3/4	2.96

**TYPE WA-R-N
WELDED TERMINAL
CONNECTOR**

For Use On CABLE TO PAD

High aluminum alloy terminal for joining a range of aluminum cable to pad.

Material: Aluminum Alloy



Notes :

- Welding to be done by customer
- Before welding scratch brush connector and conductor contact surface dry, then apply an oxide inhibitor.
- Tongue finished on one side only. For tongue finished on both sides, add suffix “-Q” to catalog number.

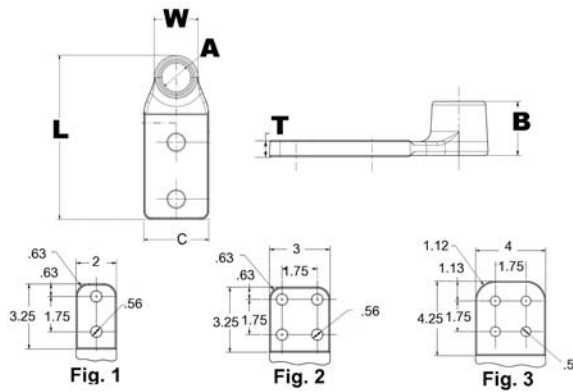

Catalog Number	Fig. #	A-Aluminum Stranded	A-Aluminum ACSR	Pad Angle	C	B	L	W	T
WA41R2N90	1	500 kcmil-650 kcmil	477.0 (18/1) Pelican kcmil-605 (24/7) Peacock kcmil	90°	2.00	1.50	5.22	1.66	1/2
WA44R2N90	1	700 kcmil-874 kcmil	605 (24/7) Peacock kcmil-715.5 (54/7) Crow kcmil	90°	2.00	1.50	5.32	1.88	1/2
WA44R34N90	2			90°	3.00	1.50	5.44	1.88	1/2
WA54R44N90	3	1400 kcmil-1600 kcmil	1272 (54/19) Pheasant kcmil	90°	4.00	2.00	7.22	2.47	5/8

**TYPE W2A-A-N
WELDMENT TERMINAL**

For Use On PAD TO TWO
CABLES

Aluminum alloy weld type terminal for joining two aluminum cables to pad. Drilling in pad conforms to NEMA standards. PENETROX™ joint compound recommended on pad contact surfaces.

Material: Aluminum Alloy

Notes :

- Welding to be done by customer
- Before welding scratch brush connector and conductor contact surface dry, then apply an oxide inhibitor.
- Tongue finished on one side only. For tongue finished on both sides, add suffix “-Q” to catalog number.

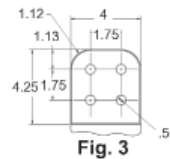
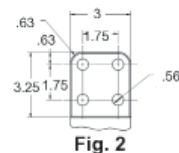
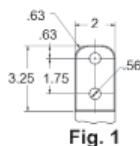
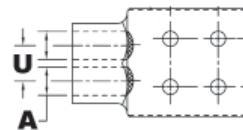
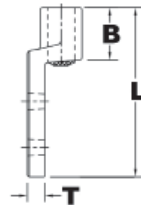

Catalog Number	Fig. #	A-Aluminum Stranded	A-Aluminum ACSR	B	U	L	T
W2A41R4N	2	500 kcmil-650 kcmil	477.0 (18/1) Pelican kcmil-605 (24/7) Peacock kcmil	1.50	1.28	4.88	1/2
W2A444A44N	3	900 kcmil-1100 kcmil	795 (54/7) Condor kcmil-954 (54/7) Cardinal kcmil	1.75	1.62	6.12	1/2
W2A444A44N90	3			1.75	1.62	7.30	1/2
W2A444A44N90	3			1.75	1.62	7.05	1/2
W2A44R4N	2	700 kcmil-874 kcmil	605 (24/7) Peacock kcmil-715.5 (54/7) Crow kcmil	1.50	1.45	5.00	1/2
W2A44R4N90	2	600 kcmil-715 kcmil	N/A	1.50	1.43	5.14	1/2
W2A454A44N	3	1113 kcmil-1351 kcmil	1033.5 (54/7) Curlew kcmil-1192.5 (45/7) Bunting kcmil	2.00	1.78	6.44	5/8
W2A486A44N	3	2300 kcmil-2500 kcmil	2156 (64/119) kcmil-2312 (76/19) Thrasher kcmil	2.62	2.50	7.46	3/4
W2A486A44N45	3			2.62	2.50	5.86	7/8
W2A486A44N90	3			2.62	2.50	7.71	7/8
W2A48A44N90	3	2000 kcmil-2250 kcmil	2034.5 (72/7) Mockingbird kcmil-2167 (72/7) Kiwi kcmil	2.62	2.25	7.84	7/8
W2A54R44N90	3	1400 kcmil-1600 kcmil	1272 (54/19) Pheasant kcmil-1510.5 (45/7) Nuthatch kcmil	2.00	1.95	7.11	3/4
W2A54R4N	2		1272 (54/19) Pheasant kcmil-1431 (54/19) Plover kcmil	2.00	1.95	5.62	3/4

**TYPE W2A-A-N
WELDMENT TERMINAL**

For Use On PAD TO TWO
CABLES



Aluminum alloy weld type terminal for joining two aluminum cables to pad. Drilling in pad conforms to NEMA standards. PENETROX™ joint compound recommended on pad contact surfaces.

Material: Aluminum Alloy

Notes :

- Welding to be done by customer
- Before welding scratch brush connector and conductor contact surface dry, then apply an oxide inhibitor.
- Tongue finished on one side only. For tongue finished on both sides, add suffix "-Q" to catalog number.

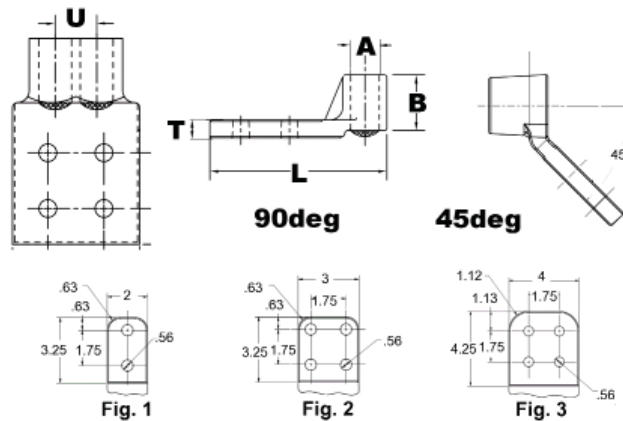

Catalog Number	Fig. #	Aluminum Stranded	Aluminum ACSR	Pad Angle	B	U	L	T
W2A444A44N90	3	900 kcmil-1100 kcmil	795 (54/7) Condor kcmil-954 (54/7) Cardinal kcmil	90°	1.75	1.62	7.30	1/2
W2A444A4N90	3			90°	1.75	1.62	7.05	1/2
W2A44R4N90	2	600 kcmil-715 kcmil	N/A	90°	1.50	1.43	5.14	1/2
W2A486A44N45	3	2300 kcmil-2500 kcmil	2156 (64/119) kcmil-2312 (76/19) Thrasher kcmil	45°	2.62	2.50	5.86	7/8
W2A486A44N90	3			90°	2.62	2.50	7.71	7/8
W2A48A44N90	3	2000 kcmil-2250 kcmil	2034.5 (72/7) Mockingbird kcmil-2167 (72/7) Kiwi kcmil	90°	2.62	2.25	7.84	7/8
W2A54R44N90	3	1400 kcmil-1600 kcmil	1272 (54/19) Pheasant kcmil-1510.5 (45/7) Nuthatch kcmil	90°	2.00	1.95	7.11	3/4

**TYPE W3A
WELDMENT TERMINAL**

For Use On PAD TO THREE
CABLES OR TUBES

Aluminum alloy weld type terminal for joining a range of aluminum cable to pad. Drilling in pad conforms to NEMA standards. PENETROX™ joint compound recommended on pad contact surfaces.

Material: Aluminum Alloy

Notes :

- Welding to be done by customer
- Before welding scratch brush connector and conductor contact surface dry, then apply an oxide inhibitor.
- Tongue finished on one side only. For tongue finished on both sides, add suffix “-Q” to catalog number.

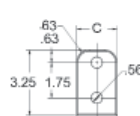
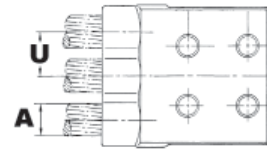
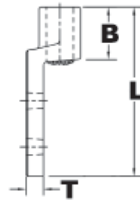

Fig. 1

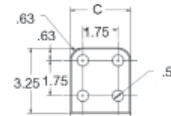

Fig. 2

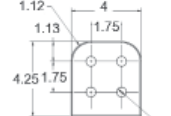

Fig. 3

Catalog Number	Fig. #	A-Aluminum Stranded	A-Aluminum ACSR	A-Aluminum tube	B	C	U	L	T
W3A444A44N	3	900 kcmil-1100 kcmil	795 (26/7) Drake kcmil-954 (54/7) Cardinal kcmil	—	1.75	4.00	1.62	6.46	5/8
W3A54R66N	—	N/A	N/A	1 1/2 IPS	2.00	5.00	1.95	7.54	5/8

**TYPE WA-A-N
WELDMENT TERMINAL**

For Use On TUBE TO FLAT

Aluminum alloy weld type terminal for joining a range of aluminum tube to pad. Drilling in pad conforms to NEMA standards. PENETROX™ joint compound recommended on pad contact surfaces.



Material: Aluminum Alloy

Notes :

- Welding to be done by customer
- Before welding scratch brush connector and conductor contact surface dry, then apply an oxide inhibitor.
- Tongue finished on one side only. For tongue finished on both sides, add suffix “-Q” to catalog number.

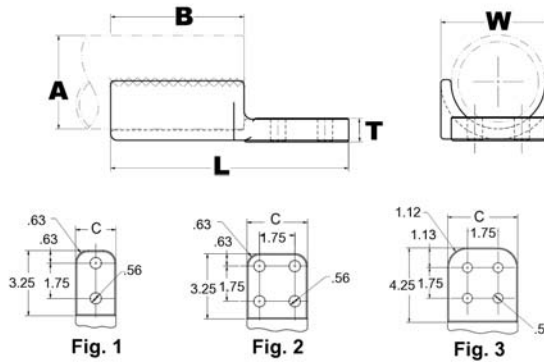

Catalog Number	Fig. #	A-Al Pipe	B	L	T	W
WA14A2N	1	3/4 IPS	2.25	5.75	3/8	1.63
WA15A2N	1	1 IPS	2.06	5.31	3/8	1.88
WA18A2N	1	2 IPS	3.50	6.75	1/2	2.75

**TYPE WA-A-N90
WELDMENT TERMINAL**

For Use On TUBE TO PAD

Aluminum alloy weld type terminal for joining aluminum tube to pad. Drilling in pad confirms to NEMA standards. PENETROX™ joint compound recommended on pad contact surfaces.

Material: Aluminum Alloy

Notes :

- Welding to be done by customer
- Before welding scratch brush connector and conductor contact surface dry, then apply an oxide inhibitor.
- Tongue finished on one side only. For tongue finished on both sides, add suffix “-Q” to catalog number.

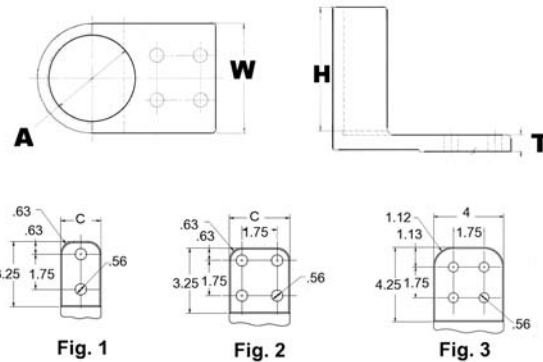

Catalog Number	Fig. #	A-Al Pipe	Pad Angle	C	H	T	W
WA20A4N90	3	3 IPS	90°	4.38	1.62	5/8	4.50

TYPE WAS-A WELDMENT TERMINAL CONNECTOR

For Use On TUBE TO PAD

Aluminum alloy weld type terminal for joining aluminum tube to copper or aluminum pads. Drilling in pad conforms to NEMA standards. PENETROX™ joint compound recommended on pad contact surfaces.



Material: Aluminum Alloy

Notes :

- Welding to be done by customer
- Before welding scratch brush connector and conductor contact surface dry, then apply an oxide inhibitor.
- Tongue finished on one side only. For tongue finished on both sides, add suffix “-Q” to catalog number.

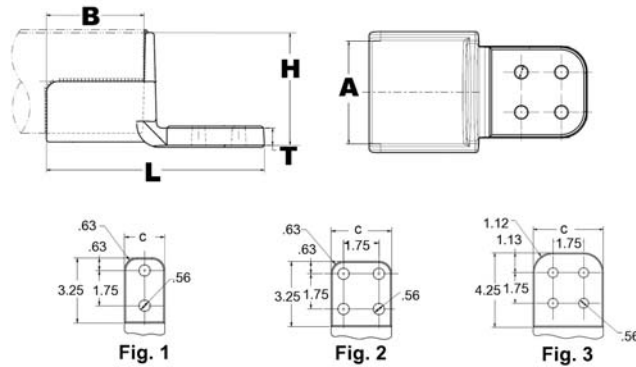

Catalog Number	Fig. #	Al Pipe	B	C	L	H	T
WAS14A-2N	1	3/4 IPS	2.50	2.00	6.50	1.34	19/50
WAS15A-2N	1	1 IPS	2.75	2.00	6.75	1.80	19/50
WAS15A-34N	2		2.75	3.00	6.75	1.80	19/50
WAS16A-2N	1	1 1/4 IPS	3.00	2.00	7.00	2.15	19/50
WAS16A34N	2		3.00	3.00	7.00	2.15	19/50
WAS17A-2N	1	1 1/2 IPS	3.25	2.00	7.25	2.38	11/25
WAS17A-34N	2		3.25	3.00	7.25	2.38	19/50
WAS18A-2N	1	2 IPS	3.50	2.00	7.50	2.84	11/25
WAS18A-34N	2		3.50	3.00	8.62	2.84	19/50
WAS18A44N	3		3.63	4.00	8.62	2.84	1/2
WAS19A-2N	1	2 1/2 IPS	3.63	2.00	7.87	3.32	14/25
WAS19A-34N	2		3.63	3.00	8.87	3.32	1/2
WAS19A-44N	3		3.63	4.00	8.87	3.32	1/2
WAS20A-2N	1	3 IPS	3.67	2.00	8.25	3.98	5/8
WAS20A-34N	2		3.75	3.00	8.25	3.98	31/50
WAS20A-44N	3		3.75	4.00	9.25	3.98	5/8
WAS21A34N	2	3 1/2 IPS	4.25	3.00	8.38	4.51	31/50
WAS22A34N	2	4 IPS	4.25	3.00	8.38	5.01	3/4
WAS22A-44N	3		4.25	4.00	9.38	5.01	3/4

**TYPE WASC
CENTREFORMED
WELDEMENT TERMINAL**

For Use On TUBE TO PAD

Aluminum alloy weldment terminal. Type WASC-A-N has one contact surface on the center line of the tube. Holes are NEMA spaced for terminating aluminum or copper mating pads. PENETROX™ joint compound recommended for use on contact surfaces.

Material: Aluminum Alloy

Notes :

- Welding to be done by customer
- Before welding scratch brush connector and conductor contact surface dry, then apply an oxide inhibitor.
- Tongue finished on one side only. For tongue finished on both sides, add suffix “-Q” to catalog number.

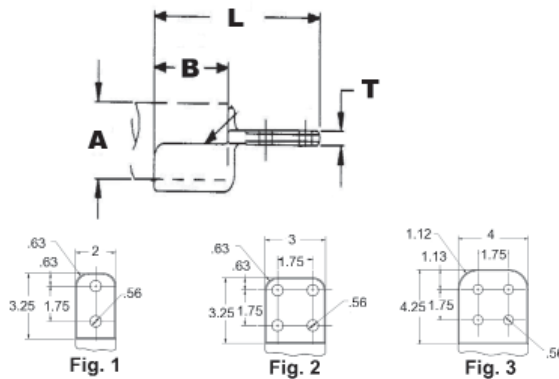

Catalog Number	Fig. #	A-Al Pipe	B	L	H	T	W
WASC15A2N	1	1 IPS	2.75	6.69	1.46	19/50	2.00
WASC16A34N	2	1 1/4 IPS	3.00	7.00	1.86	19/50	3.00
WASC17A2N	1	1 1/2 IPS	3.25	7.31	2.15	7/16	2.54
WASC17A34N	2		3.25	7.31	2.15	11/25	3.00
WASC18A2N	1	2 IPS	3.50	7.56	2.62	1/2	3.03
WASC18A34N	2		3.50	7.56	2.62	1/2	3.03
WASC19A34N	2	2 1/2 IPS	3.75	7.88	3.17	14/25	3.67
WASC19A44N	3		3.75	8.88	3.17	14/25	4.00
WASC20A2N	1	3 IPS	4.00	8.13	3.79	31/50	4.29
WASC20A34N	2		4.00	8.13	3.79	31/50	4.29
WASC20A44N	3		4.00	9.13	3.79	31/50	4.29
WASC21A34N	2	3 1/2 IPS	4.25	8.38	4.28	31/50	4.79
WASC21A44N	3		4.25	9.38	4.28	31/50	4.79
WASC22A34N	2	4 IPS	4.25	8.38	4.78	3/4	5.29
WASC22A44N	3		4.25	9.38	4.78	3/4	5.29
WASC24A44N	3	5 IPS	4.25	9.50	5.95	3/4	6.59
WASC24A66N	—		4.25	9.50	5.95	3/4	6.59

**TYPE WXA
EXPANSION TERMINAL**

For Use On TUBE TO FLAT

Aluminum alloy welded type expansion terminal connector for bus to terminal pads. Flexible aluminum straps allow for longitudinal or lateral movement and carries full current load of the joint.



Material: Aluminum Alloy
Hardware: Aluminum Hardware

Notes :

- Welding to be done by customer
- Before welding scratch brush connector and conductor contact surface dry, then apply an oxide inhibitor.
- One side of pad finished. For finished pad on both the sides, add the suffix “-Q” to catalog number.
- For six hole NEMA pad change the suffix to “-66N”.

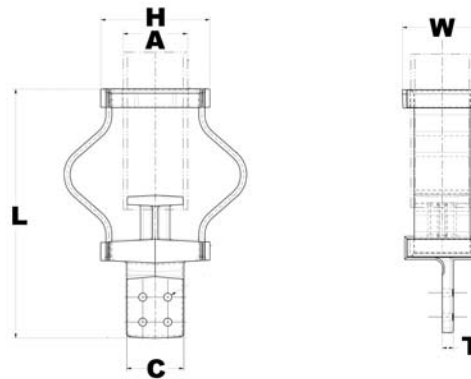

Catalog Number	A-AI Pipe Schd 40	A-AI Pipe Schd 80	C	L	H	T	W
WXA15A2N	1 IPS	N/A	2.00	10.28	3.00	3/8	2.18
WXA15A2NR90	1 IPS		2.00	10.28	3.00	3/8	2.18
WXA17A2N	1 1/2 IPS		2.00	11.59	3.87	1/2	2.68
WXA17A34N	1 1/2 IPS		3.00	11.59	3.87	1/2	2.68
WXA17A4N	1 1/2 IPS		3.00	11.84	3.87	1/2	2.68
WXA18A34N	2 IPS		3.00	12.17	4.72	1/2	3.12
WXA18A44N	2 IPS		4.00	13.23	4.72	1/2	3.12
WXA18A4N	2 IPS		3.00	11.92	4.72	1/2	3.12
WXA19A34N	2 1/2 IPS		3.00	13.26	5.10	5/8	3.74
WXA19A44N	2 1/2 IPS		4.00	14.32	5.10	5/8	3.74
WXA20A34N	3 IPS		3.00	14.32	5.94	5/8	4.53
WXA20A44N	3 IPS		4.00	15.38	5.94	5/8	4.53
WXA20A44NR90	3 IPS		4.00	15.38	5.94	5/8	4.53
WXA20A4N	3 IPS		4.38	14.13	5.94	5/8	4.53
WXA21A34NR90	3 1/2 IPS		3.00	15.34	6.58	3/4	5.14
WXA21A44N	3 1/2 IPS		4.00	16.40	6.58	5/8	5.14
WXA21A44NR90	3 1/2 IPS		4.00	16.40	6.58	3/4	5.14
WXA21A4N	3 1/2 IPS		4.75	16.40	6.58	5/8	5.14
WXA22A34N	4 IPS		3.00	15.85	7.06	3/4	5.71
WXA22A44N	4 IPS		4.00	16.91	7.06	3/4	5.71
WXA22A44NR90	4 IPS	4.00	16.91	7.06	3/4	5.71	

**TYPE WXA
EXPANSION TERMINAL**
(Continued)

For Use On TUBE TO FLAT



Catalog Number	A-Al Pipe Schd 40	A-Al Pipe Schd 80	C	L	H	T	W
WXA22A4N	4 IPS	N/A	5.25	15.60	7.06	3/4	5.71
WXA22A4NR90	4 IPS		5.25	15.60	7.06	3/4	5.71
WXA23A4N	4 1/2 IPS		3.00	16.58	7.62	3/4	6.38
WXA24A34NR90	5 IPS		3.00	17.38	8.43	3/4	6.91
WXA24A44NR90	5 IPS		4.00	18.44	8.43	3/4	6.91
WXA24A4N	5 IPS		6.50	17.85	8.43	3/4	6.91
WXA86A44N	6 IPS		4.00	18.17	10.01	7/8	8.17
WXA86A66N	6 IPS		6.00	20.14	10.01	7/8	8.17
WXA92A44N	N/A	4 IPS	4.00	16.91	7.06	3/4	5.71
WXA92A44NR90			4.00	16.91	7.06	3/4	5.71
WXA92A4N			5.25	15.60	7.06	3/4	5.71
WXA92A66N			6.00	17.57	7.06	3/4	6.00
WXA92A66NR90			6.00	17.57	7.06	3/4	5.71
WXA96A44N			4.00	18.17	10.01	7/8	8.17

**TYPE WXA
EXPANSION TERMINAL**

For Use On TUBE TO FLAT

Aluminum alloy welded type expansion terminal connector for bus to terminal pads. Flexible aluminum straps allow for longitudinal or lateral movement and carries full current load of the joint.



Material: Aluminum Alloy
Hardware: Aluminum Hardware

Notes :

- Welding to be done by customer
- Before welding scratch brush connector and conductor contact surface dry, then apply an oxide inhibitor.
- One side of pad finished. For finished pad on both the sides, add the suffix “-Q” to catalog number.
- For six hole NEMA pad change the suffix to “-66N”.

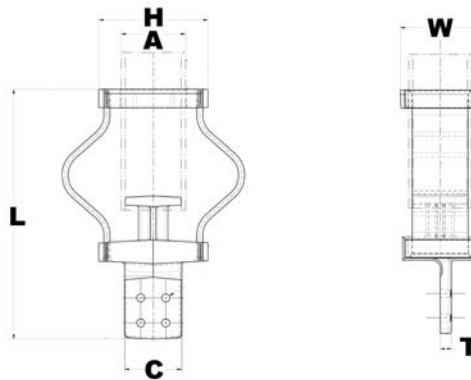

Catalog Number	A-Al Pipe Schd 40	A-Al Pipe Schd 80	C	L	H	T	W
WXA15A2NR90	1 IPS	N/A	2.00	10.28	3.00	3/8	2.18
WXA20A44NR90	3 IPS		4.00	15.38	5.94	5/8	4.53
WXA21A34NR90	3 1/2 IPS		3.00	15.34	6.58	3/4	5.14
WXA21A44NR90	3 1/2 IPS		4.00	16.40	6.58	3/4	5.14
WXA22A44NR90	4 IPS		4.00	16.91	7.06	3/4	5.71
WXA22A4NR90	4 IPS		5.25	15.60	7.06	3/4	5.71
WXA24A34NR90	5 IPS		3.00	17.38	8.43	3/4	6.91
WXA24A44NR90	5 IPS		4.00	18.44	8.43	3/4	6.91
WXA92A44NR90	N/A	4 IPS	4.00	16.91	7.06	3/4	5.71
WXA92A66NR90	N/A		6.00	17.57	7.06	3/4	5.71

TYPE WXOA EXPANSION COUPLER

For Use On PIPE TO OFFSET
PAD (90 degree)

Aluminum alloy welded type expansion coupler for mounting Bus to Bus connection on insulator. Flexible aluminum straps allow for longitudinal or lateral movement and carries full current load of the joint.

Material: Aluminum Alloy
Hardware: Aluminum Hardware

Notes :

- Welding to be done by customer
- Before welding scratch brush connector and conductor contact surface dry, then apply an oxide inhibitor.
- Shielding caps not required.
- One side of pad finished on center line of tubing.
- For finished pad on both sides add suffix “-Q” to catalog number.

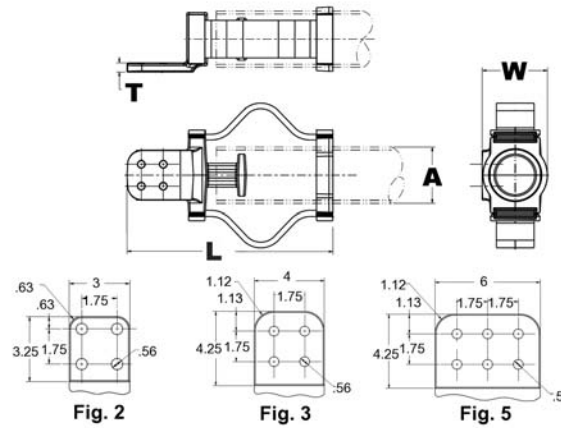

Catalog Number	Fig. #	A-Al Pipe Schd 40	A-Al Pipe Schd 80	L	T	W
WXOA20A44NR90	3	3 IPS	N/A	15.38	5/8	4.65
WXOA21A44NR90	3	3 1/2 IPS	N/A	16.42	5/8	4.77
WXOA22A44NR90	3	4 IPS	N/A	16.92	7/8	5.59
WXOA24A44NR90	3	5 IPS	N/A	18.62	7/8	5.65
WXOA92A44NR90	3	N/A	4 IPS	16.92	7/8	5.59

**TYPE SWAR
STREAMLINED
TERMINAL**

For Use On CABLE TO PAD

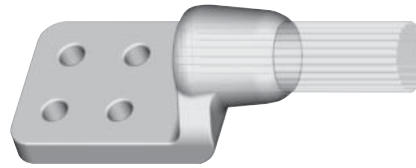

Aluminum weld type terminal for joining a range of aluminum cable to pad. Drilling in pad conforms to NEMA standards. PENETROX™ joint compound recommended on pad contact surfaces.

EHV RATED: SELF-SHIELDING UP TO 550 kV

Material: Aluminum Alloy

Notes :

- Welding to be done by customer
- Conductor smaller than 3 inch bus size is not recommended for 550kV
- Use shielding caps for high voltage applications (STS family). Shielding caps may be purchased separately
- Before welding scratch brush connector and conductor contact surface dry, then apply an oxide inhibitor.
- Please contact factory for availability of sizes.

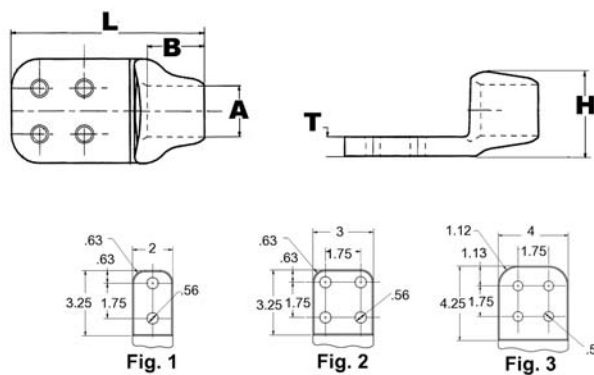

Catalog Number	Fig. #	A-Al Cable	A-ACSR	B	L	H	T
SWA444A-44N	3	900 kcmil-1100 kcmil	795 (54/7) Condor kcmil-954 (45/7) Rail kcmil	1.75	6.56	2.19	1/2
SWA486A-44N	3	2300 kcmil-2500 kcmil	2156 (64/119) kcmil-2312 (76/19) Thrasher kcmil	2.62	7.50	3.31	1-3/25

**TYPE SWAR90
TERMINAL**

For Use On TUBE TO FLAT
(90 degree)



Aluminum weld type terminal for joining a range of aluminum cable to pad. Drilling in pad conforms to NEMA standards. PENETROX™ joint compound recommended on pad contact surfaces.

EHV RATED: SELF-SHIELDING UP TO 550 kV

Material: Aluminum Alloy

Notes :

- Welding to be done by customer
- Conductor smaller than 3 inch bus size is not recommended for 550kV
- Use shielding caps for high voltage applications (STS family). Shielding caps may be purchased separately
- Before welding scratch brush connector and conductor contact surface dry, then apply an oxide inhibitor.
- Please contact factory for availability and sizes.

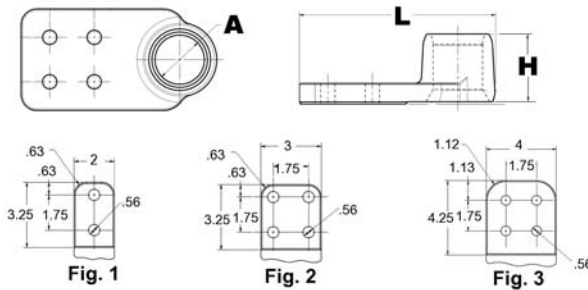

Catalog Number	Fig. #	A-AI Cable	A-ACSR	L	H
SWA486A44N90	3	2300 kcmil-2500 kcmil	2156 (64/119) kcmil-2312 (76/19) Thrasher kcmil	7.71	4.00
SWA48A44N90	3	1750 kcmil-2000 kcmil	1590 (45/7) Lapwing kcmil-1780 (84/19) Chukar kcmil	7.22	4.00

TYPE SW2A WELDMENT TERMINAL

For Use On PAD TO TWO
CABLES

Aluminum alloy weld type terminal for joining a range aluminum cables to pad. Drilling in pad conforms to NEMA standards. PENETROX™ joint compound recommended on pad contact surfaces.

EHV RATED: UP TO 500kV when used with shielding caps

Material: Aluminum Alloy

Notes :

- Welding to be done by customer
- Before welding scratch brush connector and conductor contact surface dry, then apply an oxide inhibitor.
- Please contact factory for availability of sizes.

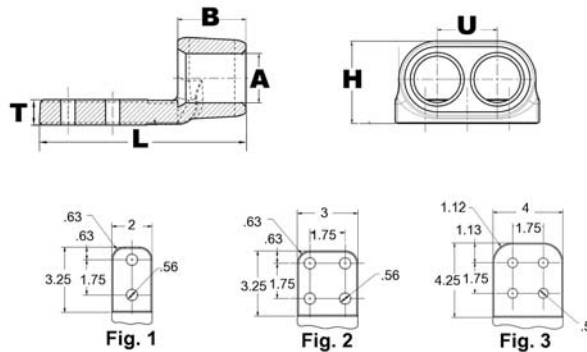

Catalog Number	Fig. #	A-Aluminum Stranded	A-Aluminum ACSR	B	U	L	H	T
SW2A444A44N	3	900 kcmil-1000 kcmil	795 (54/7) Condor kcmil-954 (45/7) Rail kcmil	1.75	1.62	6.25	2.21	1/2
SW2A444A44N90	3			1.75	1.62	6.40	1.85	14/25
SW2A44R44N90STS	3	700 kcmil-900 kcmil	636 (24/7) Rook kcmil-795 (54/7) Condor kcmil	1.50	1.49	6.74	1.60	3/4
SW2A486A44N	3	2300 kcmil-2500 kcmil	2156 (64/119) kcmil-2312 (76/19) Thrasher kcmil	2.67	2.50	7.42	3.32	1
SW2A486A44N90	3		2156 (64/119) kcmil-2167 (72/7) Kiwi kcmil	2.67	2.50	7.97	2.77	1
SW2A486A66N90	—			2.67	2.50	8.62	2.77	1
SW2A48A44N	3	2000 kcmil-2250 kcmil	2167 (72/7) Kiwi kcmil	2.62	2.25	7.42	3.32	1
SW2A58R44N	3	1700 kcmil-1900 kcmil	1510.5 (45/7) Nuthatch kcmil-1780 (54/19) kcmil	2.50	2.10	7.25	2.75	3/4

**TYPE SW2A
WELDMENT TERMINAL**

For Use On PAD TO TWO
CABLES
(90 degree)



Aluminum alloy weld type terminal for joining a range aluminum cables to pad. Drilling in pad conforms to NEMA standards. PENETROX™ joint compound recommended on pad contact surfaces.

EHV RATED: UP TO 500kV when used with shielding caps

Material: Aluminum Alloy

Notes :

- Welding to be done by customer
- Before welding scratch brush connector and conductor contact surface dry, then apply an oxide inhibitor.
- Please contact factory for availability.

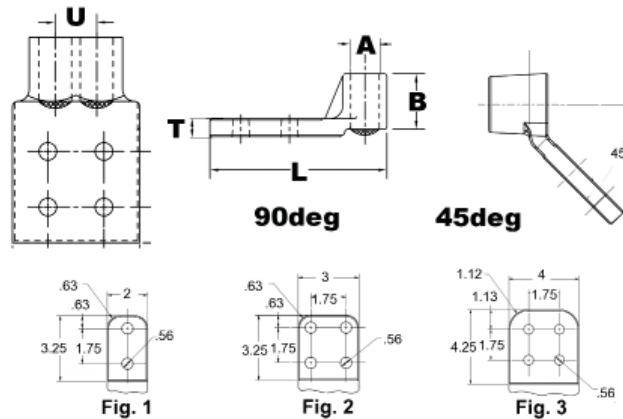

Catalog Number	Fig. #	A-Aluminum Stranded	A-Aluminum ACSR	B	U	L	T
SW2A444A44N90	3	900 kcmil-1000 kcmil	795 (54/7) Condor kcmil-954 (45/7) Rail kcmil	1.75	1.62	6.40	14/25
SW2A44R44N90STS	3	700 kcmil-900 kcmil	636 (24/7) Rook kcmil-795 (54/7) Condor kcmil	1.50	1.49	6.74	3/4
SW2A486A44N90	3	2300 kcmil-2500 kcmil	2156 (64/119) kcmil-2167 (72/7) Kiwi kcmil	2.67	2.50	7.97	1
SW2A486A66N90	—			2.67	2.50	8.62	1

**TYPE SW3A
WELDMENT TERMINAL**

For Use On PAD TO THREE
CABLES

Aluminum alloy weld type terminal for joining a range of aluminum cable to pad. Drilling in pad conforms to NEMA standards. PENETROX™ joint compound recommended on pad contact surfaces.

EHV RATED: UP TO 500kV when used with shielding caps

Material: Aluminum Alloy

Notes :

- Welding to be done by customer
- Before welding scratch brush connector and conductor contact surface dry, then apply an oxide inhibitor.
- Please contact factory for availability.

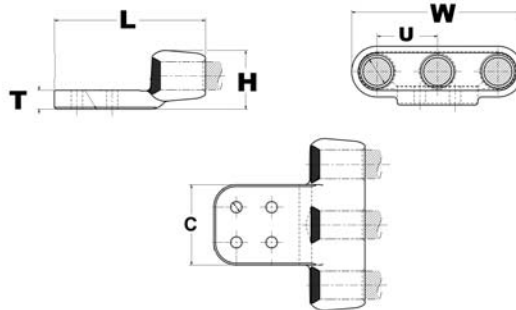
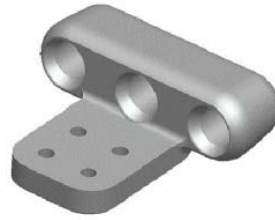

Catalog Number	A-Aluminum Stranded	A-Aluminum ACSR	C	U	L	H	T	W
SW3A454A44NSTS	1000 kcmil-1113 kcmil	900 (54/7) Canary kcmil- 1033.5 (54/7) Curlew kcmil	4.00	3.00	7.50	2.92	1	8.52

**TYPE SWA
WELDED TERMINAL**

For Use On PIPE TO PAD

Aluminum weld type terminal for joining a range of aluminum tube to pad. Drilling in pad confirms to NEMA standards. PENETROX™ joint compound recommended on pad contact surfaces.

EHV RATED: SELF-SHIELDING UP TO 550 kV

Material: Aluminum Alloy



Notes :

- Welding to be done by customer
- Use shielding caps for high voltage applications (STS family). Shielding caps may be purchased separately
- Before welding scratch brush connector and conductor contact surface dry, then apply an oxide inhibitor.
- Please contact factory for availability.

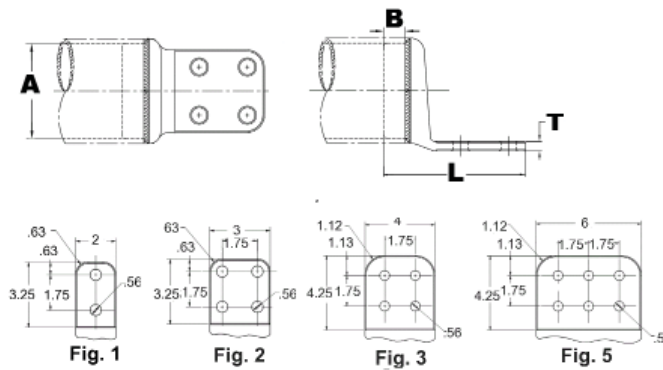

Catalog Number	Fig. #	A-Al Pipe	B	L	T
SWA18A2N	1	2 IPS	1.25	5.88	1/2
SWA18A-34N	2		1.25	5.88	1/2
SWA18A44N	3		1.25	6.95	1/2
SWA19A34N	2	2 1/2 IPS	1.50	6.36	1/2
SWA19A44N	3		1.50	7.40	1/2
SWA20A-2N	1	3 IPS	1.75	6.41	31/50
SWA21A-44N	3	3 1/2 IPS	1.75	7.47	31/50
SWA22A34N	2	4 IPS	2.00	6.51	3/4
SWA22A44N	3		2.00	7.51	3/4
SWA24A44N	3	5 IPS	2.00	7.82	3/4
SWA86A44N	3	6 IPS	2.50	7.90	1
SWA90A-34N	2	3 IPS	1.75	6.41	31/50
SWA92A-44N	3	4 IPS	2.00	7.51	3/4

**TYPE SWA90
WELDMENT TERMINAL**

For Use On PIPE TO 90/45
DEG PAD



Aluminum weld type terminal for joining a range of aluminum tube to pad. Drilling in pad conforms to NEMA standards. PENETROX™ joint compound recommended on pad contact surfaces.

EHV RATED: SELF-SHIELDING UP TO 550 kV

Material: Aluminum Alloy

Notes :

- Welding to be done by customer
- Use shielding caps for high voltage applications (STS family). Shielding caps may be purchased separately
- Before welding scratch brush connector and conductor contact surface dry, then apply an oxide inhibitor.
- Please contact factory for sizes and availability.

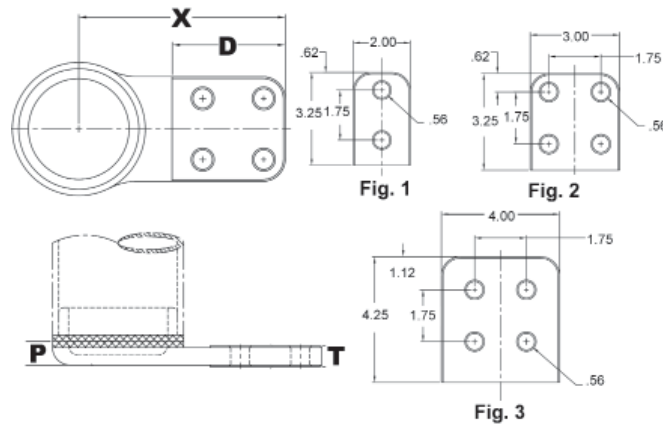

Catalog Number	Fig. #	Pad Angle	A-Al Pipe	P	X	D	T
SWA15A34N90	2	90°	1 IPS	0.63	4.22	3.25	3/8
SWA16A2N90	1		1 1/4 IPS	0.76	4.42	3.25	3/8
SWA17A2N90	1		1 1/2 IPS	0.91	4.53	3.25	1/2
SWA18A2N90	1		2 IPS	1.16	4.77	3.25	1/2
SWA18A34N90	2		2 IPS	1.16	4.77	3.25	1/2
SWA18A44N90	3		2 IPS	1.16	5.82	4.25	1/2
SWA19A34N90	2		2 1/2 IPS	1.23	5.06	3.25	1/2
SWA19A44N90	3		2 1/2 IPS	1.23	6.11	4.25	1/2
SWA20A34N90	2		3 IPS	1.22	5.33	3.25	5/8
SWA21A44N90	3		3 1/2 IPS	1.22	6.63	4.25	5/8
SWA22A44N90	3		4 IPS	1.25	6.88	4.25	3/4
SWA24A44N90	3		5 IPS	1.25	7.38	4.25	3/4
SWA24A66N90	—		5 IPS	1.25	8.22	4.25	3/4
SWA86A44N90	3		6 IPS	1.35	7.94	4.25	1
SWA86A66N90	—		6 IPS	1.35	8.72	4.25	1
SWA92A44N90	3		4 IPS	1.36	6.88	4.25	3/4

TYPE SWAC WELDED TERMINAL CONNECTOR

For Use On BUS TO PAD

Weld Type Application: Bus to Two or Four Hole Pad (centerformed)
EHV RATED: SELF-SHIELDING UP TO 550 kV

Material: Aluminum Alloy

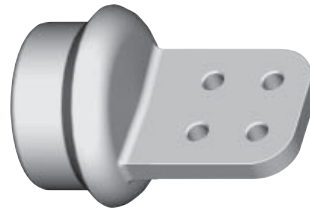

Notes :

- Welding to be done by customer
- Use shielding caps for high voltage applications (STS family). Shielding caps may be purchased separately
- Before welding scratch brush connector and conductor contact surface dry, then apply an oxide inhibitor.
- Please contact factory for availability.

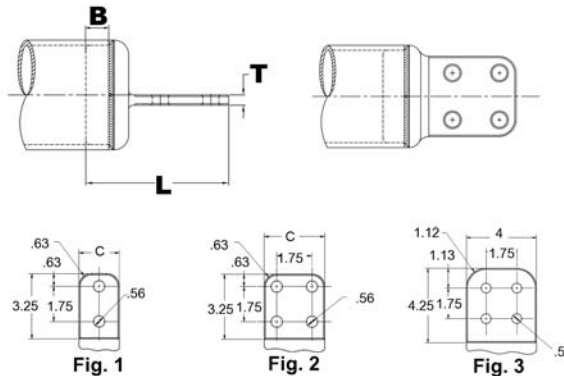

Catalog Number	Fig. #	A-Al Pipe Sch 40	A-Al Pipe Sch 80	B	L	T
SWAC18A2N	1	2 IPS	N/A	1.25	5.80	1/2
SWAC18A34N	2		N/A	1.25	5.80	1/2
SWAC18A44N	3		N/A	1.25	6.86	1/2
SWAC19A2N	1	2 1/2 IPS	N/A	1.50	6.23	1/2
SWAC19A34N	2		N/A	1.50	6.23	14/25
SWAC19A44N	3		N/A	1.50	7.29	1/2
SWAC20A2N	1	3 IPS	N/A	1.75	6.30	5/8
SWAC20A34N	2		N/A	1.75	6.30	31/50
SWAC20A44N	3		N/A	1.75	7.36	31/50
SWAC21A34N	2	3 1/2 IPS	N/A	1.75	6.30	5/8
SWAC21A44N	3		N/A	1.75	7.36	31/50
SWAC22A34N	2	4 IPS	N/A	2.00	6.40	3/4
SWAC22A44N	3		N/A	2.00	7.40	3/4
SWAC23A34N	2	4 1/2 IPS	N/A	2.00	6.23	5/8
SWAC23A44N	3		N/A	2.00	7.66	3/4
SWAC24A34N	2	5 IPS	N/A	2.00	6.68	3/4
SWAC24A44N	3		N/A	2.00	7.72	3/4
SWAC58A34N	2	N/A	2 IPS	1.25	5.80	1/2
SWAC83A44N	3	8 OD	N/A	2.39	7.75	1-8/13
SWAC86A44N	3	6 IPS	N/A	2.50	7.75	1
SWAC86A66N	—		N/A	2.39	7.75	1

**TYPE SWAC
WELDED TERMINAL
CONNECTOR (Continued)**

For Use On BUS TO PAD

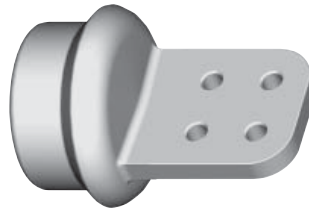

Catalog Number	Fig. #	A-Al Pipe Sch 40	A-Al Pipe Sch 80	B	L	T
SWAC90A34N	2	N/A	3 IPS	1.75	6.30	31/50
SWAC92A44N	3		4 IPS	2.00	7.40	3/4
SWAC94A44N	2		5 IPS	2.00	7.72	3/4
SWAC96A44N	3		6 IPS	2.50	7.75	1

**TYPE SWACC
WELDMENT TERMINAL**

For Use On TUBE TO PAD

Weld Type Application: Bus to Two or Four Hole Pad (centerformed)
EHV RATED: SELF-SHIELDING UP TO 550 kV



Material: Aluminum Alloy

Notes :

- Welding to be done by customer
- Use shielding caps for high voltage applications (STS family). Shielding caps may be purchased separately
- Before welding scratch brush connector and conductor contact surface dry, then apply an oxide inhibitor.
- Please contact factory for sizes and availability.

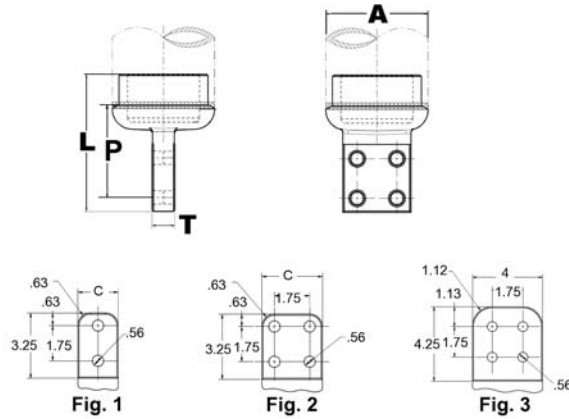

Catalog Number	A-Al Pipe Sch 40	A-Al Pipe Sch 80	L	T	P
SWACC22A4N	4 IPS	N/A	6.06	1	4.58
SWACC90A4N	N/A	3 IPS	6.02	1	4.02

**TYPE SW3AN8
WELDMENT TERMINAL**

For Use On PIPE TO (3) PADS

Weld type application : Bus to Two or Four Hole Pad

EHV RATED: UP TO 550kV when used with shielding caps

Material: Aluminum Alloy



Notes :

- Welding to be done by customer
- Before welding scratch brush connector and conductor contact surface dry, then apply an oxide inhibitor.
- Please contact factory for sizes and availability.

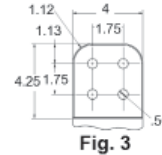
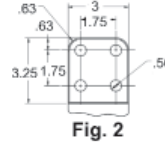
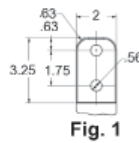
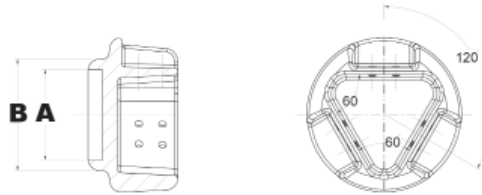

Catalog Number	Fig. #	A-Al Pipe	B
SW3A22A44N8	3	4 IPS	6.09
SW3A24A44N8	3	5 IPS	7.16
SW3A83A44N8	3	8 OD	9.75
SW3A86A44N8	3	6 IPS	8.25

**TYPE SW2AG3
WELDMENT TERMINAL**

For Use On TUBE TO PAD

Weld type application : Bus to Two or Four Hole Pad

EHV RATED: UP TO 550kV when used with shielding caps

Material: Aluminum Alloy



Notes :

- Welding to be done by customer
- Before welding scratch brush connector and conductor contact surface dry, then apply an oxide inhibitor.
- Please contact factory for availability.

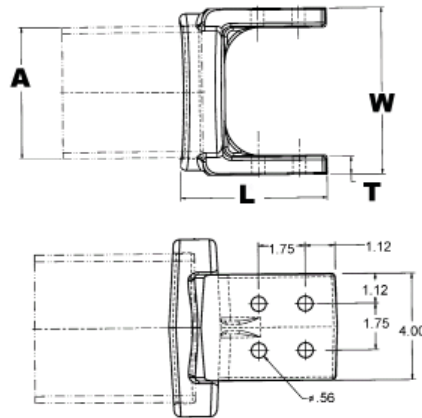

Catalog Number	A-Al Pipe	L	T	W
SW2A20A44NG3	3 IPS	6.00	3/4	4.59
SW2A22A44NG3	4 IPS	6.26	3/4	5.59
SW2A24A44NG3	5 IPS		3/4	6.65
SW2A24A46NG3	5 IPS	7.07	7/8	7.06
SW2A83A46NG3	8 OD	8.14	7/8	9.06
SW2A86A44NG3	6 IPS	6.26	3/4	7.72

**TYPE SWXA-K8
WELDMENT TERMINAL**

For Use On TUBE TO PAD

Aluminum alloy expansion terminal with Corona rings for joining (welded) bus to four hole or six hole pad. Flexible aluminum straps allow for longitudinal or lateral movement and carries full current load of the joint.
EHV RATED: SELF-SHIELDING UP TO 550kV



Material: Aluminum Alloy
Hardware: Aluminum Hardware

Notes :

- Welding to be done by customer
- Before welding scratch brush connector and conductor contact surface dry, then apply an oxide inhibitor.
- One side of pad finished. For finished pad on both the sides add suffix “-Q” to catalog number
- For six hole NEMA pad, change the suffix to “-66N”

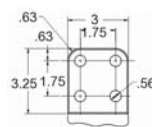
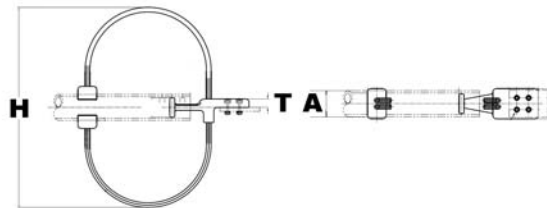

Fig. 2

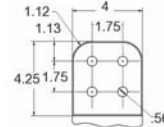

Fig. 3

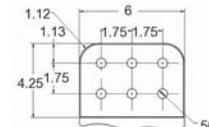

Fig. 5

Catalog Number	Fig #.	A-AI Pipe Schd 40	A-AI Pipe Schd 80	H	T
SWXA19A4NK8	3	2 1/2 IPS	N/A	27.00	1
SWXA20A4NK8	3	3 IPS	N/A	26.38	1
SWXA86A44NR90KG1	3	6 IPS	N/A	29.12	1-1/4
SWXA94A4NK8	3	N/A	5 IPS	28.06	1
SWXA96A4NK8	3		6 IPS	29.12	1

**TYPE SWXA-90K
WELDMENT TERMINAL**

For Use On TUBE TO PAD

Aluminum alloy expansion terminal with Corona rings for joining (welded) bus to four hole or six hole pad. Flexible aluminum straps allow for longitudinal or lateral movement and carries full current load of the joint. **EHV RATED: SELF-SHIELDING UP TO 550kV**

Material: Aluminum Alloy
Hardware: Aluminum Hardware

Notes :

- Welding to be done by customer
- Before welding scratch brush connector and conductor contact surface dry, then apply an oxide inhibitor.
- One side of pad finished. For finished pad on both the sides add suffix “-Q” to catalog number
- For six hole NEMA pad, change the suffix to “-66N”

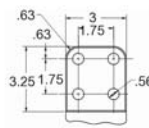
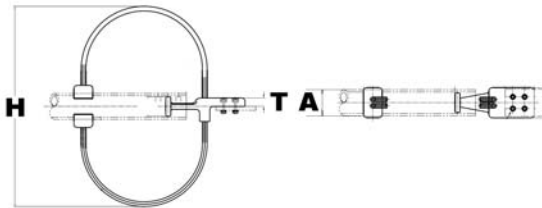

Fig. 2

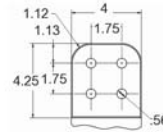

Fig. 3

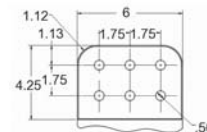
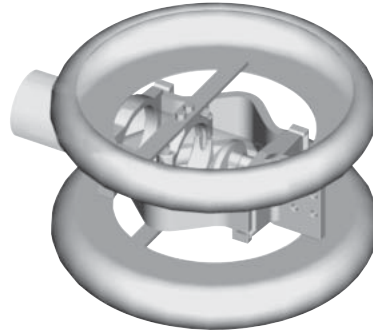

Fig. 5

Catalog Number	Fig. #	A-AI Pipe Schd 40	H	T
SWXA86A44NR90KG1	3	6 IPS	29.12	1-1/4

**TYPE SWXA
WELDMENT TERMINAL**

For Use On TUBE TO PAD



Aluminum alloy expansion terminal with Corona rings for joining (welded) bus to four hole or six hole pad. Flexible aluminum straps allow longitudinal or lateral movement and carries full current load of the joint.
EHV RATED: UP TO 550kV

Material: Aluminum Alloy
Hardware: Aluminum Hardware

Notes :

- Welding to be done by customer
- Before welding scratch brush connector and conductor contact surface dry, then apply an oxide inhibitor.
- One side of pad finished. For finished pad on both the sides add suffix “-Q” to catalog number
- For six hole NEMA pad, change the suffix to “-66N”

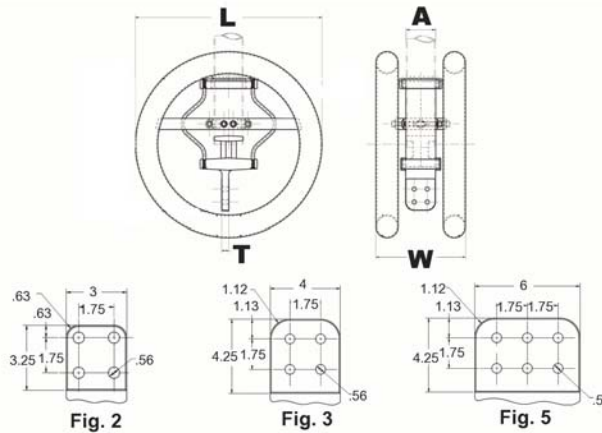

Catalog Number	Fig #.	A-AI Pipe Schd 40	A-AI Pipe Schd 80	T	L	W	
SWXA20A4N	2	3 IPS	N/A	3/4	25.00	13.18	
SWXA22A44N	3	4 IPS		1	25.00	12.00	
SWXA22A4N	2			7/8	25.00	13.87	
SWXA24A44N	3	5 IPS		3/4	26.00	15.44	
SWXA24A4N	2			3/4	25.00	14.50	
SWXA24A66N	5			3/4	25.00	14.50	
SWXA94A66N	5			3/4	25.00	14.18	
SWXA86A44N	3	6 IPS		1	25.00	15.50	
SWXA86A4N	2			1	25.00	15.50	
SWXA86A66N	5			1	25.00	15.50	
SWXA92A4N	2	N/A		4 IPS	7/8	25.00	13.87
SWXA92A66N	5				3/4	25.00	12.00
SWXA94A4N	2		5 IPS	7/8	25.00	14.50	
SWXA94A6N	5			3/4	25.00	14.50	

**TYPE SWXA-A-NR90
WELDMENT TERMINAL**

For Use On TUBE TO PAD

Aluminum alloy expansion terminal with Corona rings for joining (welded) bus to four hole or six hole pad. Flexible aluminum straps allow longitudinal or lateral movement and carries full current load of the joint.
EHV RATED: UP TO 550kV



Material: Aluminum Alloy
Hardware: Aluminum Hardware

Notes :

- Welding to be done by customer
- Before welding scratch brush connector and conductor contact surface dry, then apply an oxide inhibitor.
- One side of pad finished. For finished pad on both the sides add suffix “-Q” to catalog number
- For six hole NEMA pad, change the suffix to “-66N”

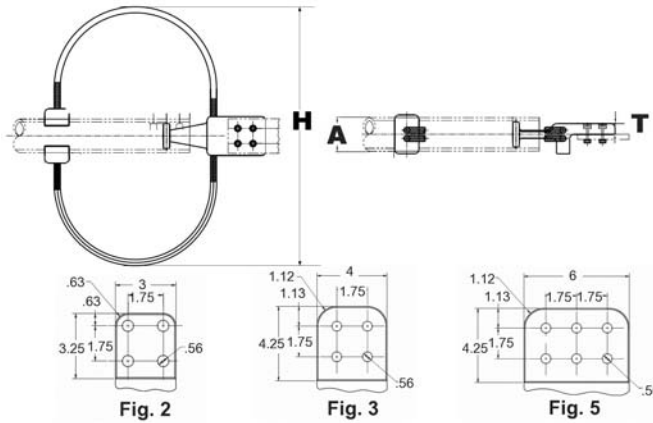

Catalog Number	Fig. #	A-AI Pipe Schd 40	A-AI Pipe Schd 80	H	T
SWXA86A44NR90	3	6 IPS	6 IPS	29.12	1-1/4

TYPE YNA-R
YNA-R

For Use On Compression Terminal for ACSR, ACAR and Stranded Aluminum Cable

Compression terminal for ACSR, ACAR and SAC Transmission lines. Two hole NEMA tongue through 556.5 kcmil ACSR. Four hole NEMA pad supplied on larger sizes. When used with YTW-R or YTW-A, the 15° angle tongue provides either a 0° or 30° tap. Uses same dies as equivalent full-tension sleeve or deadend. Barrel pre-filled with PENETROX™ joint compound and capped. Pad coated with oxide retardant.

Material: Aluminum

Notes :

- Please contact factory for other sizes, combinations and availability

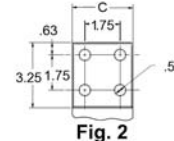
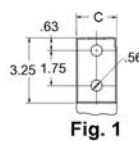

Catalog Number	Fig. #	A	C	L	T
YNA32R	2	300.0 (26/7) Ostrich-336.4 (30/7) Oriole	1.68	8.96	0.39
YNA32R4N	2		3	9.14	0.38
YNA34R	2	397.5 (18/1) Chickadee-397.5 (30/7) Larkspur	1.78	9.08	0.46
YNA36R	2	477.0 (18/1) Pelican-477.0 (30/7) Hen	1.96	9.47	0.48
YNA39R	2	556.5 (24/7) Parakeet kcmil-556.5 (30/7) Eagle kcmil	2.08	9.84	0.53
YNA43R	2	605 (24/7) Peacock kcmil-666.6 (24/7) Flamingo kcmil	3.07	10.07	0.36
YNA451R	2	715.5 (54/7) Crow-874.5 (54/7) Crane	3.22	10.28	0.45
YNA49R	2	900 (54/7) Canary-1113 (54/19) Finch	3.22	10.46	0.52

Table of Contents - Aluminum Welded Couplers

	Type WS-A Tube to Tube (Internal)	A-211
	Type WSLB-A Tube to Tube (Internal)	A-212
	Type WR Tube to Tube Reducer (Internal)	A-213
	Type WRLB Pipe to Pipe Reducer (Internal)	A-214
	Type WXP Expansion Pipe to Pipe	A-215
	Type WXHP-A Tube to Tube with Mounting Bus	A-216
	Type SWL Pipe to Pipe Elbow	A-217
	Type WSNS Pipe to Cable	A-218
	Type SWR Tube to Tube Reducer (Internal)	A-219
	Type SWXP Expansion Tube to Tube	A-220
	Type SWXHP Expansion Tube to Tube	A-221

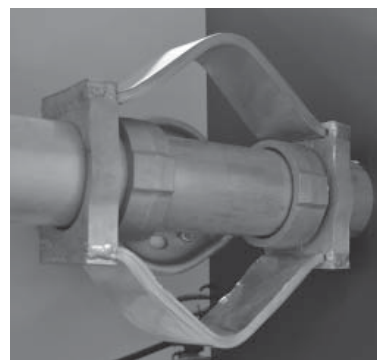
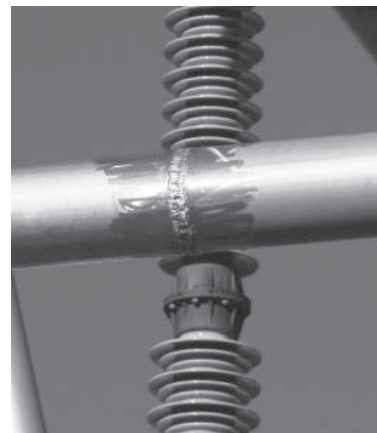

**TYPE WS-A
WELDED RIGID
COUPLER**

For Use On TUBE TO TUBE

High strength aluminum alloy coupler for joining aluminum tubes, both ends of the coupler are chamfered for easier insertion into the bus. The slotted design assures a tight fit, allows variation in tube id and assures good contact over the entire length of the coupler.

EHV RATED: SELF-SHIELDING UP TO 550 kV

Material: Aluminum Alloy

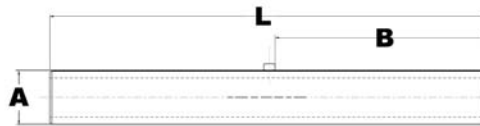

Notes :

- Welding to be done by customer
- Conductor smaller than 3 inch bus size is not recommended for 550kV
- Before welding scratch brush connector and conductor contact surface dry, then apply an oxide inhibitor.
- Contact factory for sizes and availability.

Catalog Number	A - IPS Pipe Sch40	A - IPS Pipe Sch80	B	L
WS14A	3/4 IPS	N/A	2.13	4.50
WS15A	1 IPS		2.13	4.50
WS16A	1 1/4 IPS		3.60	7.50
WS17A	1 1/2 IPS		4.36	9.00
WS18A	2 IPS		5.88	12.00
WS19A	2 1/2 IPS		7.31	15.00
WS20A	3 IPS		8.81	18.00
WS21A	3 1/2 IPS		8.75	18.00
WS22A	4 IPS		8.75	18.00
WS24A	5 IPS		8.75	18.00
WS86A	5 IPS		8.75	18.00
WS59A	N/A		2 1/2 IPS	7.31
WS90A		3 IPS	8.81	18.00
WS91A		3 1/2 IPS	8.75	18.00
WS92A		4 IPS	8.75	18.00
WS94A		5 IPS	8.75	18.00
WS96A		6 IPS	8.75	18.00

**TYPE WSLB-A
WELDED RIGID
COUPLER**

For Use On TUBE TO TUBE

Aluminum alloy bus to bus coupler.
**EHV RATED: SELF-SHIELDING UP
TO 550kV**

Material: Aluminum Alloy



Notes :

- Welding to be done by customer
- Please contact factory for other sizes, combinations and availability
- Before welding scratch brush connector and conductor contact surface dry, then apply an oxide inhibitor.
- Conductors smaller than 3 inch bus size are not recommended for 550kV.

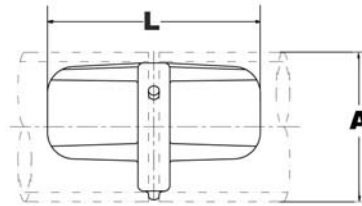
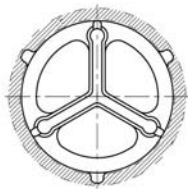

Catalog Number	A - IPS Pipe Sch40	A - IPS Pipe Sch80	L
WSLB15A	1 IPS	N/A	5.00
WSLB16A	1 1/4 IPS		5.00
WSLB17A	1 1/2 IPS		5.00
WSLB18A	2 IPS		5.00
WSLB19A	2 1/2 IPS		5.00
WSLB20A	3 IPS		5.00
WSLB21A	3 1/2 IPS		5.00
WSLB22A	4 IPS		5.00
WSLB24A	5 IPS		5.00
WSLB58A	N/A		2 IPS
WSLB90A		3 IPS	5.00
WSLB92A		4 IPS	5.00
WSLB94A		5 IPS	5.00
WSLB96A		6 IPS	5.00

**TYPE WR
COUPLER/REDUCER**

For Use On TUBE TO TUBE

Weld type application : Bus to Bus
aluminum coupler

Material: Aluminum Alloy



Notes :

- Welding to be done by customer
- Before welding scratch brush connector and conductor contact surface dry, then apply an oxide inhibitor.
- Please contact factory for sizes and availability.

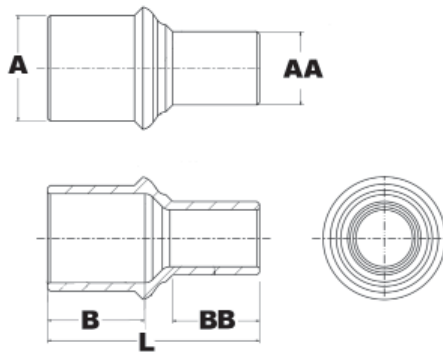

Catalog Number	A - Run Pipe	AA - Tap Pipe	B	BB	L
WR24A19AL	5 IPS	2 1/2 IPS	5.00	2.50	9.62
WR92A22A	4 IPS	4 IPS	9.00	9.00	18.89

**TYPE WRLB
COUPLER/REDUCER**

For Use On TUBE TO TUBE

Aluminum alloy welded splice for joining a range of tube.

Material: Aluminum Alloy



Notes :

- Welding to be done by customer
- Before welding scratch brush connector and conductor contact surface dry, then apply an oxide inhibitor.
- Please contact factory for availability.

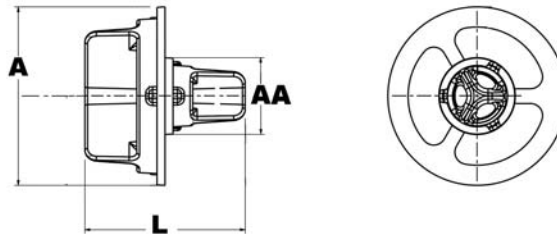

Catalog Number	A - Run Pipe	AA - Tap Pipe	L
WRLB24A18A	5 IPS	2 IPS	5.00
WRLB86A22A	6 IPS	4 IPS	5.00

**TYPE WXP
EXPANSION COUPLER**

For Use On PIPE TO PIPE

Aluminum alloy expansion coupler for joining equal size tube on end. Flexible Aluminum strap allows longitudinal movement of the tube.



Material: Aluminum Alloy
Hardware: Aluminum Hardware

Notes :

- Welding to be done by customer
- Conductor smaller than 3 inch bus size is not recommended for 550kV
- Before welding scratch brush connector and conductor contact surface dry, then apply an oxide inhibitor.
- Contact factory for sizes and availability.

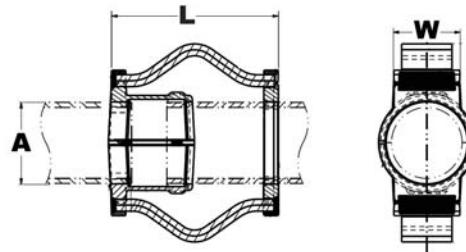

Catalog Number	A-Al Pipe Schd 40	A-Al Pipe Schd 80	L	W
WXP18A18A	2 IPS	N/A	8.16	3.12
WXP19A19A	2 1/2 IPS		9.25	3.75
WXP20A20A	3 IPS		10.31	4.53
WXP21A21A	3 1/2 IPS		11.88	5.16
WXP22A22A	4 IPS		12.00	5.72
WXP24A24A	5 IPS		13.66	6.91
WXP92A92A	N/A	4 IPS	12.00	5.72
WXP94A94A		5 IPS	13.66	6.91

TYPE WXHP-A EXPANSION COUPLER

For Use On TUBE TO TUBE

Aluminum alloy welded type expansion coupler for mounting Bus to Bus connection on insulator. Flexible aluminum straps allow longitudinal or lateral movement and carries full current load of the joint.



Material: Aluminum Alloy
Hardware: Aluminum Hardware

Notes :

- Welding to be done by customer
- Conductor smaller than 3 inch bus size is not recommended for 550kV
- Before welding scratch brush connector and conductor contact surface dry, then apply an oxide inhibitor.
- Bus support couplers are supplied without bus end plugs. If end plugs are required add suffix “-EP” to catalog number

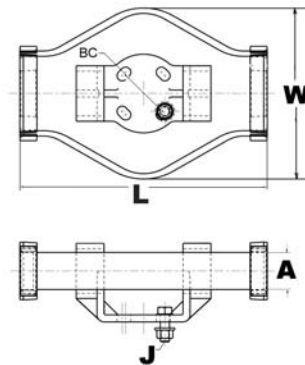

Catalog Number	A-Pipe Size Schd 40	BC	J	L	W
WXHP18A3	2 IPS	3.00	5/8	13.34	9.24
WXHP19A5	2 1/2 IPS	5.00		14.00	10.52
WXHP20A5	3 IPS			15.06	11.66
WXHP22A5	4 IPS			15.62	13.78
WXHP24A5	5 IPS			16.28	15.63
WXHP86A5	6 IPS			16.88	16.75

**TYPE SWL
WELDED ELBOW**

For Use On Bus To Bus Elbow
(90 degrees)



Weld type Application : Bus to Bus
Elbow
(90 degree)
**EHV RATED : SELF-SHIELDING UP
TO 550kV**

Material: Aluminum Alloy

Notes :

- Welding to be done by customer
- Before welding scratch brush connector and conductor contact surface dry, then apply an oxide inhibitor.
- Conductor smaller than 3 inch bus size not recommended for 550kV.
- For 45 degree angle add suffix "-45" to catalog number.

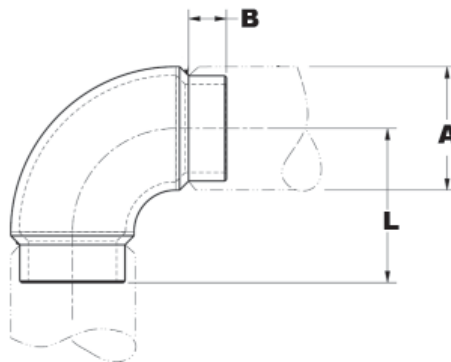

Catalog Number	A-AI Pipe Sch 40	A-AI Pipe Sch 80	L	B
SWL14A	3/4 IPS	N/A	2.38	0.50
SWL17A	1 1/2 IPS		3.71	1.00
SWL18A	2 IPS		4.83	1.00
SWL19A	2 1/2 IPS		5.32	1.38
SWL20A	3 IPS		6.43	1.38
SWL21A	3 1/2 IPS		7.12	1.38
SWL22A	4 IPS		7.88	1.38
SWL24A	5 IPS		8.94	1.62
SWL86A	6 IPS		9.48	1.62
SWL58A	N/A		2 IPS	4.83
SWL59A		2 1/2 IPS	5.32	1.38
SWL96A		6 IPS	9.48	1.62

**TYPE WSNS
STREAMLINED END
CONNECTOR**

For Use On CABLE TO CABLE

Weld type Application : Streamlined
End Connector
**EHV RATED : SELF-SHIELDING UP
TO 550kV**



Material: Aluminum Alloy

Notes :

- Welding to be done by customer
- Please contact factory for other sizes, combinations and availability
- Before welding scratch brush connector and conductor contact surface dry, then apply an oxide inhibitor.
- Conductor smaller than 3 inch bus size not recommended for 550kV.

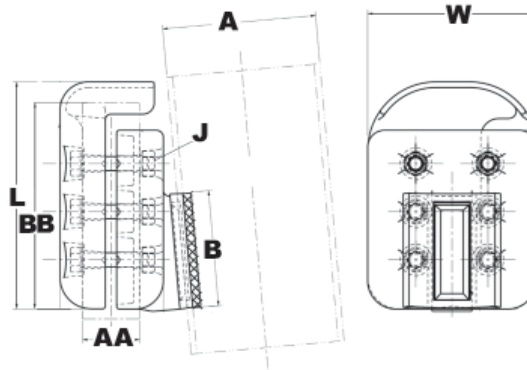

Catalog Number	A - Run Al Pipe	AA - Tap Al Cable	B	J - Dia.	BB	L	W
WSNS22A47AS7HQ	4 IPS	1800 kcmil	5.09	5/8	7.88	10.00	7.44
WSNS22A496AS7HQ	4 IPS	4000 kcmil	5.09	5/8	7.88	10.00	7.44
WSNS86A47AS7	6 IPS	1800 kcmil	5.09	5/8	7.88	10.00	7.44
WSNS86A496AS7HQ	6 IPS	4000 kcmil	5.09	5/8	7.88	10.00	7.44

**TYPE SWR
REDUCER**

For Use On TUBE TO TUBE

Aluminum alloy streamlined reducing coupler.

EHV RATED: SELF-SHIELDING UP TO 550 kV

Material: Aluminum Alloy



Notes :

- Welding to be done by customer
- Before welding scratch brush connector and conductor contact surface dry, then apply an oxide inhibitor.
- Please contact factory for availability.

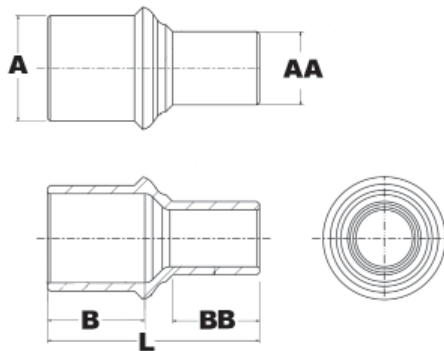

Catalog Number	A - Run Pipe	AA - Tap Pipe	B	BB	L
SWR24A21A	5 IPS	3 1/2 IPS	4.00	4.00	9.75
SWR24A22A	5 IPS	4 IPS	4.00	4.00	9.75

**TYPE SWXP
EXPANSION COUPLER**

For Use On TUBE TO TUBE

Aluminum alloy welded type expansion coupler for Bus to Bus connection. Flexible aluminum straps allows longitudinal or lateral movement and carries full current load of the joint.
EHV RATED: SELF-SHIELDING UP TO 550kV

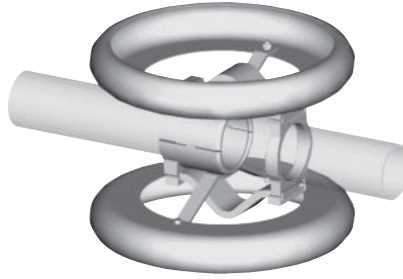

Material: Aluminum Alloy
Hardware: Aluminum Hardware

Notes :

- Welding to be done by customer
- Conductor smaller than 3 inch bus size is not recommended for 550kV
- Before welding scratch brush connector and conductor contact surface dry, then apply an oxide inhibitor.
- Contact factory for availability of sizes.

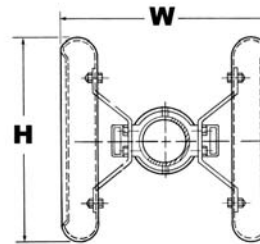
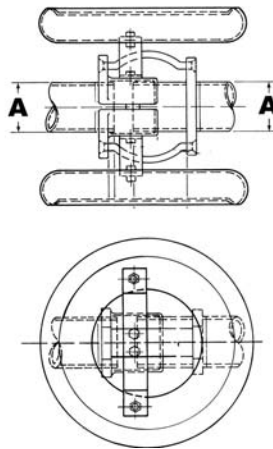

Catalog Number	A-AI Pipe Schd 40	A-AI Pipe Schd 80	H	W
SWXP20A20A	3 IPS	N/A	22.00	17.05
SWXP22A22A	4 IPS		22.00	18.89
SWXP24A24A	5 IPS		26.00	19.25
SWXP83A83A	8 OD		26.00	22.63
SWXP86A86A	6 IPS		26.00	20.31
SWXP90A90A	N/A	3 IPS	26.00	17.05
SWXP92A92A		4 IPS	22.00	18.89
SWXP94A94A		5 IPS	22.00	18.89
SWXP96A96A		6 IPS	26.00	18.11

**TYPE SWXHP
EXPANSION COUPLER**

For Use On TUBE TO TUBE

Aluminum alloy welded type expansion coupler for mounting Bus to Bus connection on insulator. Flexible aluminum straps allow longitudinal or lateral movement and carries full current load of the joint.

EHV RATED: SELF-SHIELDING UP TO 550kV

Material: Aluminum Alloy
Hardware: Aluminum Hardware

Notes :

- Specify base mounting hardware, if required, by adding suffix -B to catalog number
- Welding to be done by customer
- Please contact factory for other sizes, combinations and availability
- Before welding scratch brush connector and conductor contact surface dry, then apply an oxide inhibitor.
- Bus support couplers are supplied without bus end plugs. If end plugs are required add suffix "-EP" to catalog number

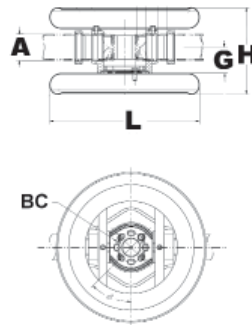
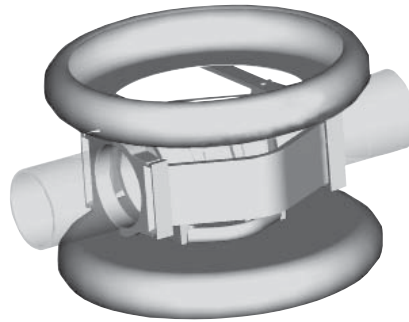

Catalog Number	A-Pipe Size Schd 40	A-Pipe Size Schd 80	BC	G	L	H
SWXHP19A5	2 1/2 IPS	N/A	5.00	3.12	26.00	12.77
SWXHP20A5	3 IPS			3.62	26.00	13.62
SWXHP21A5	3 1/2 IPS			4.00	26.00	14.25
SWXHP22A5	4 IPS			4.50	26.00	14.90
SWXHP24A5	5 IPS			5.25	26.00	16.31
SWXHP86A5	6 IPS			5.50	26.00	17.34
SWXHP59A5	N/A	2 1/2 IPS		3.12	26.00	12.80
SWXHP90A5		3 IPS		3.62	26.00	13.62
SWXHP91A5		3 1/2 IPS		4.00	26.00	14.25
SWXHP92A5		4 IPS		4.50	26.00	15.00
SWXHP94A5		5 IPS		5.00	26.00	16.03
SWXHP96A5		6 IPS		5.50	26.00	17.06

Table of Contents - Aluminum Welded Bus Supports

	Type WHRH-A Pipe	A-225
	Type WHO-A Pipe	A-226
	Type WVH Vertical Pipe	A-227
	Type WXHP-A Pipe	A-228
	Type SWHRH Pipe	A-229
	Type SWOH Pipe	A-230
	Type SWSUH Pipe	A-231
	Type SWVH Vertical Pipe	A-232
	Type SWXHP Expansion Pipe to Pipe	A-233

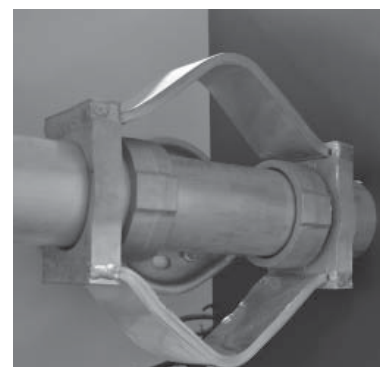
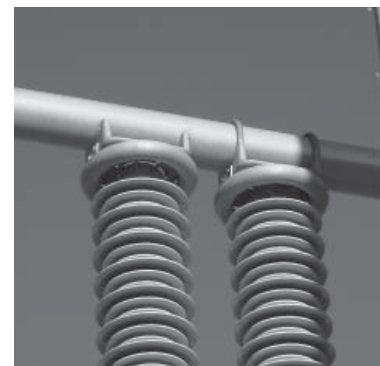

TYPE WHRH-A BUS SUPPORT

For Use On TUBE TO PAD

Fixed or slip fit bus support to insulator.

Material: Aluminum Alloy



Notes :

- Conductor smaller than 3 inch bus size is not recommended for 550kV
- G dimension conforms to NEMA standards.
- For base mounting hardware add suffix “-B” to catalog number.

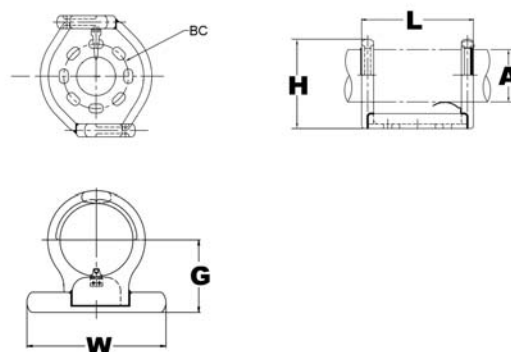

Catalog Number	A-Pipe Size	BC	G	L	H	W
WHRH15A3CH	1 IPS	3	2.00	7.76	3.28	6.26
WHRH17A3CH	1 1/2 IPS		2.50	7.76	4.08	6.26
WHRH18A3CH	2 IPS		2.75	7.76	4.58	6.26
WHRH18A5CH	2 IPS	5	3.12	9.37	4.58	8.61
WHRH19A3CH	2 1/2 IPS	3		7.76	5.21	6.26
WHRH19A5CH	2 1/2 IPS	5	3.62	9.37	5.21	8.61
WHRH20A3CH	3 IPS	3	4.00	7.76	6.15	6.26
WHRH20A5CH	3 IPS	5		9.37	6.15	8.61
WHRH21A3CH	3 1/2 IPS	3		7.76	6.77	6.26
WHRH21A5CH	3 1/2 IPS	5	4.50	9.37	6.77	8.61
WHRH21A7CH	3 1/2 IPS	7		11.37	6.77	10.61
WHRH22A3CH	4 IPS	3		7.76	7.52	6.26
WHRH22A5CH	4 IPS	5	5.00	9.37	7.52	8.61
WHRH22A7CH	4 IPS	7		11.37	7.52	10.61
WHRH24A3CH	5 IPS	3		7.76	8.68	6.26
WHRH24A5CH	5 IPS	5	5.50	9.37	8.68	8.61
WHRH24A7CH	5 IPS	7		11.37	8.68	10.61
WHRH86A5CH	6 IPS	5		9.37	9.71	8.61
WHRH86A7CH	6 IPS	7	11.37	9.71	10.61	

TYPE WOH-A WELDED BUS SUPPORT

For Use On TUBE TO PAD

Weld type Application: Aluminum alloy support for mounting tube on post or pedestal insulators. This can be used for slip or fixed bus support. Properly proportioned to minimize conductor corrosion due to galvanic action.

Material: Aluminum Alloy

Notes :

- Welding to be done by customer
- Contact factory for availability of sizes.

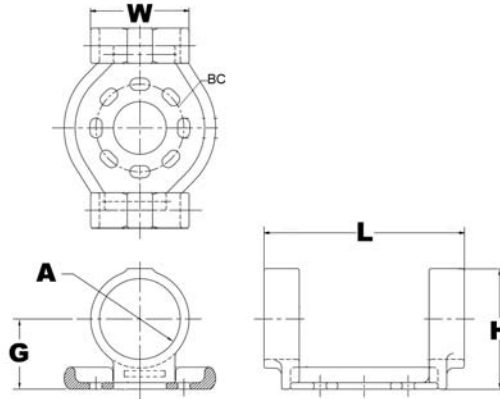

Catalog Number	A-Pipe Size	BC	G	L	H	W
WOH16A3CH	1 1/4 IPS	3.00	2.25	6.76	3.66	6.26
WOH17A3CH	1 1/2 IPS		2.50	8.26	4.04	6.26
WOH18A3CH	2 IPS		2.75	8.76	4.53	6.26
WOH18A5CH	2 IPS	5.00	3.12	10.37	4.53	8.61
WOH19A3CH	2 1/2 IPS	3.00		8.76	5.15	6.26
WOH19A5CH	2 1/2 IPS	5.00	3.12	10.37	5.15	8.61
WOH20A3CH	3 IPS	3.00	3.62	9.26	5.96	6.26
WOH20A5CH	3 IPS	5.00		10.87	5.96	8.61
WOH21A3CH	3 1/2 IPS	3.00	4.00	9.26	6.60	6.26
WOH21A5CH	3 1/2 IPS	5.00		10.87	6.60	8.61
WOH22A3CH	4 IPS	3.00	4.50	9.76	7.35	6.26
WOH22A5CH	4 IPS	5.00		11.37	7.35	8.61

**TYPE WVH
BUS SUPPORT**

For Use On BASE TO TUBE

Aluminum alloy welded vertical bus support for aluminum bus to insulator.

Material: Aluminum Alloy

Notes :

- Welding to be done by customer
- Please contact factory for availability
- Before welding scratch brush connector and conductor contact surface dry, then apply an oxide inhibitor.
- For base mounted hardware add suffix “-B” to catalog number.

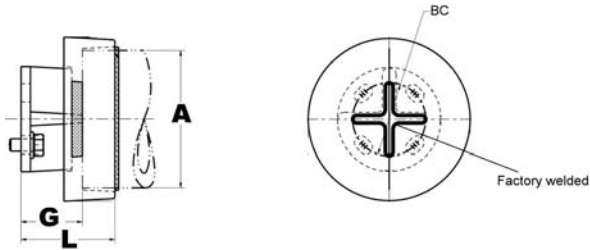

Catalog Number	A-Pipe Size	BC	L	G
WVH15A3	1 IPS	3.00	3.69	2.31
WVH16A3	1 1/4 IPS			2.31
WVH17A3	1 1/2 IPS			2.31
WVH18A3	2 IPS			2.31
WVH18A5	2 IPS	5.00	1.75	0.38
WVH19A3	2 1/2 IPS	3.00	3.69	2.31
WVH19A5	2 1/2 IPS	5.00	3.62	2.25
WVH20A3	3 IPS	3.00	3.44	2.06
WVH20A5	3 IPS	5.00	3.62	2.25
WVH21A3	3 1/2 IPS	3.00	3.69	2.31
WVH21A5	3 1/2 IPS	5.00	3.62	2.25
WVH22A3	4 IPS	3.00	3.69	2.31
WVH22A5	4 IPS	5.00	3.62	2.25
WVH24A3	5 IPS	3.00	3.75	2.38
WVH24A5	5 IPS	5.00		2.38
WVH86A3	6 IPS	3.00		2.38

TYPE WXHP-A EXPANSION COUPLER

For Use On TUBE TO TUBE

Aluminum alloy welded type expansion coupler for mounting Bus to Bus connection on insulator. Flexible aluminum straps allow longitudinal or lateral movement and carries full current load of the joint.



Material: Aluminum Alloy
Hardware: Aluminum Hardware

Notes :

- Welding to be done by customer
- Conductor smaller than 3 inch bus size is not recommended for 550kV
- Before welding scratch brush connector and conductor contact surface dry, then apply an oxide inhibitor.
- Bus support couplers are supplied without bus end plugs. If end plugs are required add suffix “-EP” to catalog number

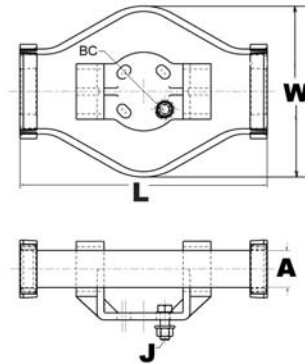

Catalog Number	A-Pipe Size Schd 40	BC	J	L	W
WXHP18A3	2 IPS	3.00	5/8	13.34	9.24
WXHP19A5	2 1/2 IPS	5.00		14.00	10.52
WXHP20A5	3 IPS			15.06	11.66
WXHP22A5	4 IPS			15.62	13.78
WXHP24A5	5 IPS			16.28	15.63
WXHP86A5	6 IPS			16.88	16.75

**TYPE SWHRH
BUS SUPPORT**

For Use On BUS TO
INSULATOR

Welded type application : Fixed or Slip
Fit Bus Support to insulator.

Material: Aluminum Alloy

Notes :

- Conductor smaller than 3 inch bus size is not recommended for 550kV
- G dimension confirms to NEMA standards.
- For Base mounting hardware add suffix “-B” to catalog number (example : SWHRH22A-5B).

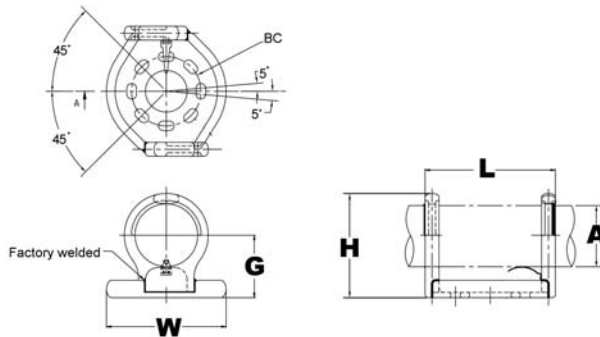

Catalog Number	A-Pipe Size	BC	G	L	H	W
SWHRH18A3CH	2 IPS	3.00	2.75	7.76	4.58	6.26
SWHRH18A5CH	2 IPS	5.00		9.37	4.58	8.61
SWHRH19A3CH	2 1/2 IPS	3.00	3.12	7.76	5.21	6.26
SWHRH19A5CH	2 1/2 IPS	5.00		9.37	5.21	8.61
SWHRH20A3CH	3 IPS	3.00	3.62	7.76	6.15	6.26
SWHRH20A5CH	3 IPS	5.00		9.37	6.15	8.61
SWHRH21A3CH	3 1/2 IPS	3.00	4.00	7.76	6.77	6.26
SWHRH21A5CH	3 1/2 IPS	5.00		9.37	6.77	8.61
SWHRH22A3CH	4 IPS	3.00	4.50	7.76	7.52	6.26
SWHRH22A5CH	4 IPS	5.00		9.37	7.52	8.61
SWHRH24A3CH	5 IPS	3.00	5.00	7.76	8.68	6.26
SWHRH24A5CH	5 IPS	5.00		9.37	8.68	8.61
SWHRH86A3CH	6 IPS	3.00	5.50	7.76	9.71	8.61
SWHRH86A5CH	6 IPS	5.00		9.37	9.71	8.61

**TYPE SWOH
BUS SUPPORT**

For Use On BUS SUPPORT TO INSULATOR

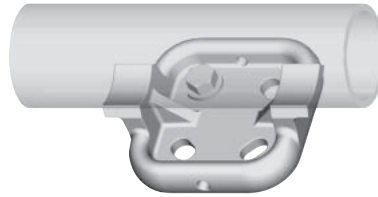

Weld type Application : Fixed Bus Support to Insulator.

EHV RATED : SELF-SHIELDING UP TO 550kV when used on Corona free Post Insulators

Material: Aluminum Alloy

Notes :

- Welding to be done by customer
- Please contact factory for other sizes, combinations and availability
- Before welding scratch brush connector and conductor contact surface dry, then apply an oxide inhibitor.
- "G" dimension confirms to NEMA standards.
- For Base Mounting hardware add suffix "-B" to catalog number (SWOH22A-5B).

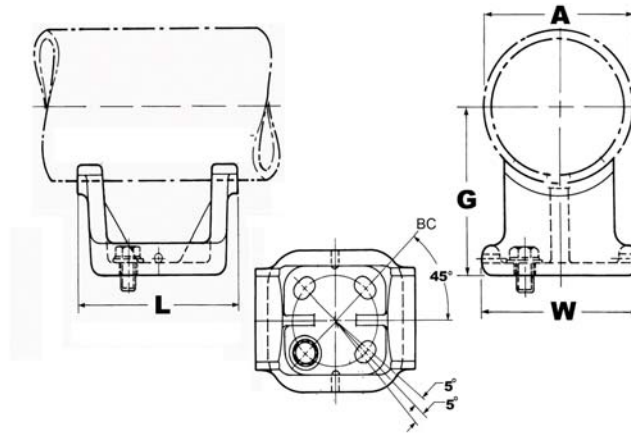

Catalog Number	A-Pipe Size	BC	G	L	W
SWOH18A5	2 IPS	5.00	2.75	7.48	6.76
SWOH19A3	2 1/2 IPS	3.00	3.12	6.06	5.19
SWOH19A5	2 1/2 IPS	5.00		7.62	6.80
SWOH20A3	3 IPS	3.00	3.00	5.78	4.96
SWOH20A5	3 IPS	5.00		7.20	6.29
SWOH21A5	3 1/2 IPS		4.00	7.58	6.76
SWOH22A3	4 IPS	3.00	4.50	5.82	4.96
SWOH22A5	4 IPS	5.00		7.68	6.57
SWOH24A5	5 IPS		5.00	7.68	6.57
SWOH86A5	6 IPS		5.50	7.68	6.57

**TYPE SWSUH
BUS SUPPORT**

For Use On BUS SUPPORT TO
INSULATOR CAP

Weld type Application : Slide or Fixed
Bus Support to Insulator.
EHV RATED: SELF-SHIELDING UP
TP 550kV when used on Corona free
Post Insulators.

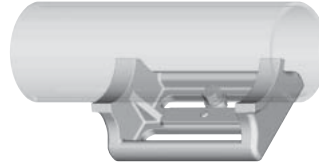

Material: Aluminum Alloy

Notes :

- Welding to be done by customer
- Conductor smaller than 3 inch bus size is not recommended for 550kV
- Before welding scratch brush connector and conductor contact surface dry, then apply an oxide inhibitor.
- "G" dimension conforms to NEMA standards.
- For Base Mounting hardware add SUFFIX "B" to catalog number (example : SWSUH22A-5B).
- Four aluminum alloy bushings are supplied for slip fit installations.

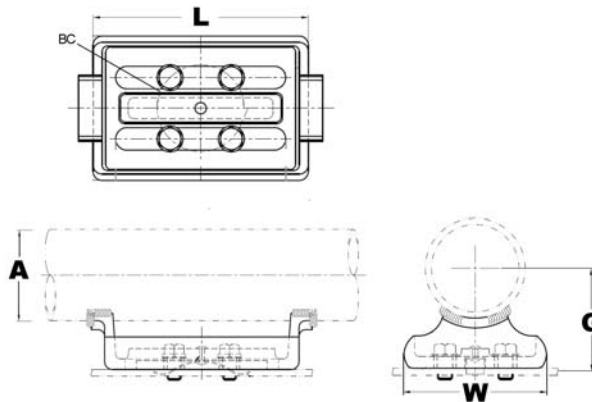

Catalog Number	A-Pipe Size	BC	G	L	W
SWSUH18A3	2 IPS	3.00	2.75	8.75	5.00
SWSUH18A5	2 IPS	5.00		10.62	6.75
SWSUH19A3	2 1/2 IPS	3.00	3.12	8.75	5.00
SWSUH19A5	2 1/2 IPS	5.00		10.62	6.75
SWSUH20A3	3 IPS	3.00	3.62	8.75	5.00
SWSUH20A5	3 IPS	5.00		10.62	6.75
SWSUH21A3	3 1/2 IPS	3.00	4.00	8.75	5.00
SWSUH21A5	3 1/2 IPS	5.00		10.62	6.75
SWSUH22A-3	4 IPS	3.00	4.50	8.75	5.00
SWSUH22A5	4 IPS	5.00		10.62	6.75
SWSUH22A7	4 IPS	7.00	4.54	12.38	8.16
SWSUH24A5	5 IPS	5.00	5.00	10.62	6.75
SWSUH86A-5	6 IPS			10.62	6.75

**TYPE SWVH
BUS SUPPORT**

For Use On TUBE TO
INSULATOR

Welded type vertical Bus support.
EHV RATED : SELF SHIELDING UP
TO 550kV when used on corona free
Post Insulator.

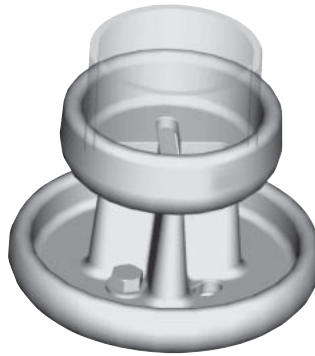

Material: Aluminum Alloy

Notes :

- Welding to be done by customer
- Please contact factory for other sizes, combinations and availability
- Before welding scratch brush connector and conductor contact surface dry, then apply an oxide inhibitor.
- G dimension conforms to NEMA standards.

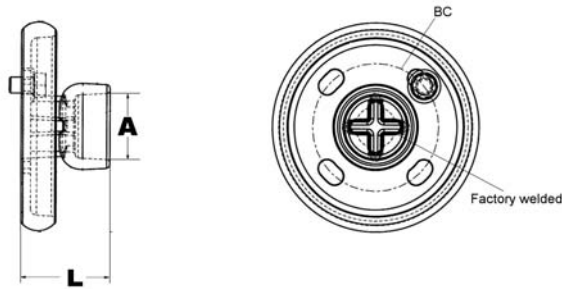

Catalog Number	A-Pipe Size	BC	L
SWVH20A5	3 IPS	5.00	4.25
SWVH22A-5	4 IPS		
SWVH22A-7	4 IPS	7.00	
SWVH24A5	5 IPS	5.00	4.75
SWVH24A7	5 IPS	7.00	1.38
SWVH86A5	6 IPS	5.00	5.38
SWVH86A7	6 IPS	7.00	

**TYPE SWXHP
EXPANSION COUPLER**

For Use On TUBE TO TUBE

Aluminum alloy welded type expansion coupler for mounting Bus to Bus connection on insulator. Flexible aluminum straps allow longitudinal or lateral movement and carries full current load of the joint.

EHV RATED: SELF-SHIELDING UP TO 550kV

Material: Aluminum Alloy
Hardware: Aluminum Hardware

Notes :

- Specify base mounting hardware, if required, by adding suffix -B to catalog number
- Welding to be done by customer
- Please contact factory for other sizes, combinations and availability
- Before welding scratch brush connector and conductor contact surface dry, then apply an oxide inhibitor.
- Bus support couplers are supplied without bus end plugs. If end plugs are required add suffix “-EP” to catalog number

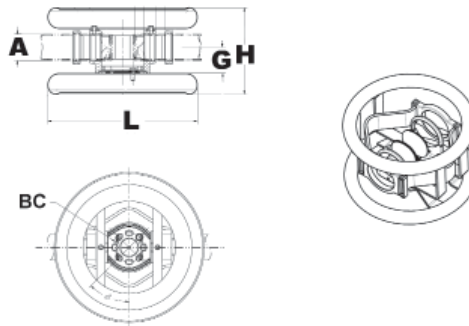
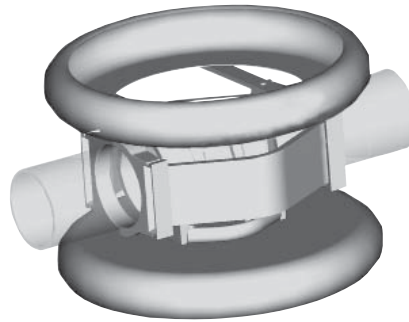

Catalog Number	A-Pipe Size Schd 40	A-Pipe Size Schd 80	BC	G	L	H
SWXHP19A5	2 1/2 IPS	N/A	5.00	3.12	26.00	12.77
SWXHP20A5	3 IPS			3.62	26.00	13.62
SWXHP21A5	3 1/2 IPS			4.00	26.00	14.25
SWXHP22A5	4 IPS			4.50	26.00	14.90
SWXHP24A5	5 IPS			5.25	26.00	16.31
SWXHP86A5	6 IPS			5.50	26.00	17.34
SWXHP59A5	N/A	2 1/2 IPS		3.12	26.00	12.80
SWXHP90A5		3 IPS		3.62	26.00	13.62
SWXHP91A5		3 1/2 IPS		4.00	26.00	14.25
SWXHP92A5		4 IPS		4.50	26.00	15.00
SWXHP94A5		5 IPS		5.00	26.00	16.03
SWXHP96A5		6 IPS		5.50	26.00	17.06

Table of Contents - Aluminum Welded T / Tap / A-Frames

	Type WT Pipe Run & Tap	A-237
	Type WSNT Pipe Run & Cable Tap	A-238
	Type SWAB Pipe Run & Tap Pad	A-239
	Type SWT Pipe Run & Pipe Tap	A-240
	Type SW3AB Pipe Run 3 Tap Pads	A-241
	Type SW2T Pipe Run Cable Tap	A-242
	Type SWXT Expansion Pipe Run & Tap	A-243
	Type WAT Pipe Run to 2 Pipe Tap	A-244
	Type SWAT Pipe Run to 2 Pipe Tap	A-245
	Type SWT75 Pipe Run & Tap	A-247
	Type SWT80 Pipe Run & Tap	A-248

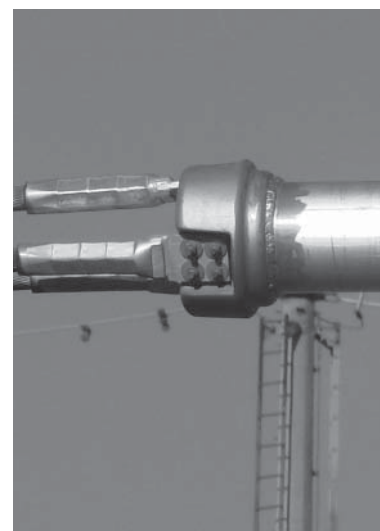

**TYPE WT
WELDED T-CONNECTOR**

For Use On TUBE TO TUBE

Aluminum alloy weldment T-Connector for joining a range of aluminum tube. PENETROX™ joint compound recommended on contact surfaces.

Material: Aluminum Alloy

Notes :

- Welding to be done by customer
- Before welding scratch brush connector and conductor contact surface dry, then apply an oxide inhibitor.
- Please contact factory for availability.

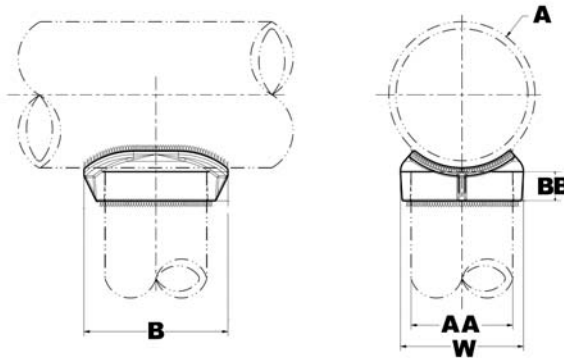

Catalog Number	A - Run Pipe	AA - Tap Pipe	B	BB	W
WT18A15A	2 IPS	1 IPS	2.38	0.75	2.25
WT18A18A	2 IPS	2 IPS	4.13	1.00	3.00
WT19A15A	2 1/2 IPS	1 IPS	2.38	0.75	2.25
WT19A19A	2 1/2 IPS	2 1/2 IPS	5.13	1.38	3.63
WT20A15A	3 IPS	1 IPS	2.34	0.75	1.84
WT20A18A	3 IPS	2 IPS	4.13	1.00	3.25
WT20A19A	3 IPS	2 1/2 IPS	5.13	1.38	3.88
WT20A20A	3 IPS	3 IPS	6.13	1.38	4.25
WT21A15A	3 1/2 IPS	1 IPS	2.38	0.75	2.38
WT21A21A	3 1/2 IPS	3 1/2 IPS	7.06	1.38	5.00
WT22A15A	4 IPS	1 IPS	2.38	0.75	2.44
WT22A19A	4 IPS	2 1/2 IPS	5.16	1.38	3.59
WT22A20A	4 IPS	3 IPS	6.12	1.38	4.25
WT22A22A	4 IPS	4 IPS	7.73	1.38	5.34
WT23A20A	4 1/2 IPS	3 IPS	6.19	1.38	4.56
WT23A23A	4 1/2 IPS	4 1/2 IPS	6.69	1.62	5.88
WT24A18A	5 IPS	2 IPS	4.12	1.00	3.31
WT24A19A	5 IPS	2 1/2 IPS	5.00	1.38	4.06
WT24A24A	5 IPS	5 IPS	9.56	1.60	6.19
WT83A22A	8 OD	4 IPS	7.81	1.38	5.97

**TYPE WSNT
T-CONNECTOR**

For Use On PIPE TO CABLE

Weld type Application: T-Connector
aluminum tube to cable.

**EHV RATED: SELF-SHIELDING UP
TO 550 kV**

Material: Aluminum Alloy



Notes :

- Welding to be done by customer
- Before welding scratch brush connector and conductor contact surface dry, then apply an oxide inhibitor.
- Contact factory for availability of other sizes.

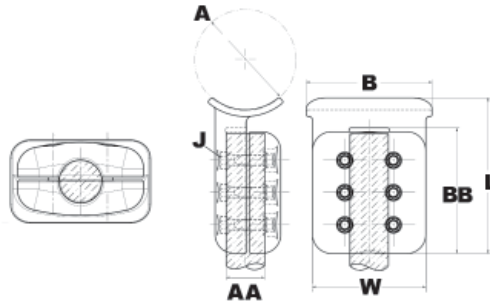

Catalog Number	A - Run Al Pipe	AA - Tap Al Cable	B	J - Dia.	BB	L	W
WSNT86A496AS7	6 IPS	4000 kcmil	8.25	5/8	8.00	10.23	7.44

**TYPE SWAB
WELDED T-CONNECTOR**

For Use On BUS TO PAD

Aluminum bar tap: Bus to Pad.
**EHV RATED: UP TO 550kV when
used with shielding caps**

Material: Aluminum Alloy



Notes :

- Welding to be done by customer
- Before welding scratch brush connector and conductor contact surface dry, then apply an oxide inhibitor.
- Tongue finished on both sides.

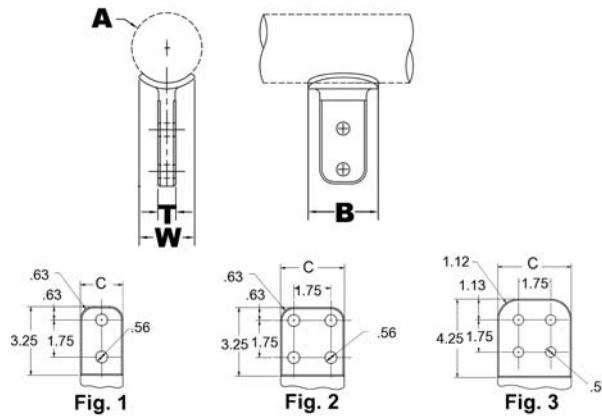

Catalog Number	Fig. #	A-Al Pipe	B	C	T	W
SWAB19A2N	1	2 1/2 IPS	3.00	2.00	3/8	1.32
SWAB19A-34N	2	1 IPS -2 1/2 IPS	4.00	3.00	1/2	1.32
SWAB22A2N	1	4 IPS	3.00	2.00	3/4	2.40
SWAB22A-34N	2	2 1/2 IPS -4 IPS	4.00	3.00	3/4	2.40
SWAB22A-44N	3		4.50	4.00	3/4	2.40
SWAB86A2N	1	6 IPS	3.00	2.00	1	2.62
SWAB86A34N	2		4.00	3.00	1	2.62
SWAB86A-44N	3	3 IPS -6 IPS	4.50	4.00	1	2.62

**TYPE SWT
WELDED T-CONNECTOR**

For Use On TUBE TO TUBE

Weld Type Application : Bus to Bus
T-Connector.

**EHV RATED: SELF SHIELDING UP
TO 550 kV**

Material: Aluminum Alloy



Notes :

- Welding to be done by customer
- Before welding scratch brush connector and conductor contact surface dry, then apply an oxide inhibitor.
- Conductor smaller than 3 inch bus size not recommended for 550kV.
- Contact factory for availability of other sizes.

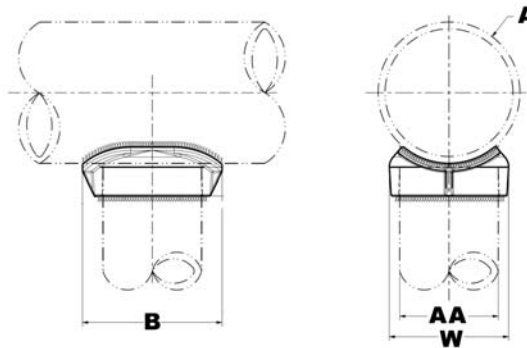

Catalog Number	A - Run Pipe	AA - Tap Pipe	B	BB	W
SWT17A15A	1 IPS -1 1/2 IPS	1 IPS	2.38	0.75	2.00
SWT17A16A	1 1/4 IPS-1 1/2 IPS	1 1/4 IPS	2.69	1.00	2.38
SWT17A17A	1 1/2 IPS	1 1/2 IPS	3.19	1.00	2.64
SWT19A19A	2 1/2 IPS	2 1/2 IPS	4.00	1.38	3.78
SWT21A15A	2 IPS -3 1/2 IPS	1 IPS	2.38	0.75	2.28
SWT21A17A	2 IPS -3 1/2 IPS	1 1/2 IPS	3.19	1.00	2.62
SWT21A18A	2 IPS -3 1/2 IPS	2 IPS	4.00	1.00	3.33
SWT21A19A	2 1/2 IPS -3 1/2 IPS	2 1/2 IPS	4.00	1.38	3.78
SWT21A20A	3 IPS -3 1/2 IPS	3 IPS	4.56	1.38	4.52
SWT21A21A	2 IPS -3 1/2 IPS	3 1/2 IPS	5.50	1.38	5.50
SWT22A15A	4 IPS	1 IPS	2.38	0.75	2.50
SWT22A18A	4 IPS	2 IPS	4.00	1.00	3.50
SWT22A19A	4 IPS	2 1/2 IPS	4.00	1.38	4.80
SWT22A22A	4 IPS	4 IPS	6.00	1.38	5.60
SWT24A20A	5 IPS	3 IPS	4.72	1.38	4.40
SWT24A22A	5 IPS	4 IPS	6.00	1.38	5.60
SWT24A24A	5 IPS	5 IPS	7.38	1.62	6.84
SWT86A86A	6 IPS	6 IPS	8.00	1.62	6.84

**TYPE SW3AB
T CONNECTOR**

For Use On BUS TO PAD

Aluminum bar tap: Bus to Pad.
**EHV RATED: UP TO 550kV when
used with shielding caps**

Material: Aluminum Alloy
Hardware: Aluminum Hardware

Notes :

- Welding to be done by customer
- Before welding scratch brush connector and conductor contact surface dry, then apply an oxide inhibitor.
- Tongue finished on both sides.

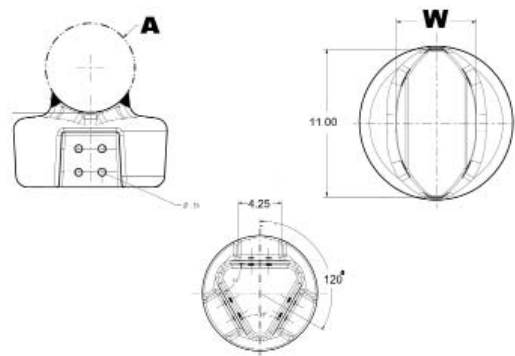

Catalog Number	Al Pipe	W
SW3AB20A44N8	3 IPS	3.50
SW3AB22A44N8	4 IPS	4.50
SW3AB24A44N8	5 IPS	5.50
SW3AB83A44N8	8 OD	8.00
SW3AB86A44N8	6 IPS	6.50

**TYPE SW2T
TAP CONNECTOR**

For Use On TUBE TO CABLE

Aluminum alloy welded type tap connector for joining a wide range of aluminum tube to twin cables.

EHV RATED: UPTO 550kV when used with shielding caps



Material: Aluminum Alloy

Notes :

- Welding to be done by customer
- Before welding scratch brush connector and conductor contact surface dry, then apply an oxide inhibitor.
- Tongue finished on both sides.
- Terminals to be provided by customer.
- Contact factory for availability of sizes.

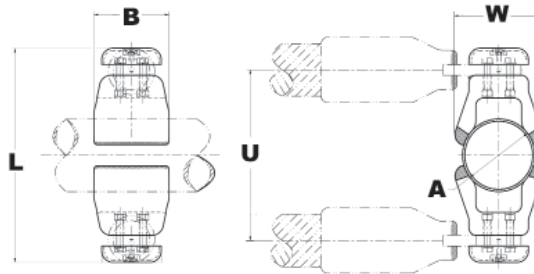

Catalog Number	A - Run Pipe	B	L	U	W
SW2T24ACG2	5 IPS	5.75	16.38	13.00	6.39

**TYPE SWXT
EXPANSION T
CONNECTOR**

For Use On BUS TO BUS

Aluminum alloy welded type expansion T-Connector for Bus to Bus connection.

EHV RATED: SELF-SHIELDING UP TO 550kV

Material: Aluminum Alloy

Hardware: Aluminum Hardware

Notes :

- Welding to be done by customer
- Conductor smaller than 3 inch bus size is not recommended for 550kV
- Before welding scratch brush connector and conductor contact surface dry, then apply an oxide inhibitor.
- Contact factory for availability of sizes.

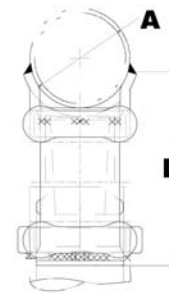
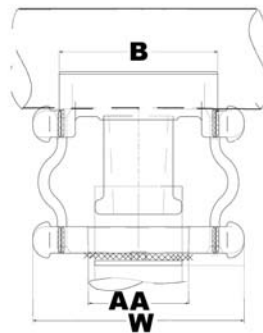

Catalog Number	A - Run Pipe	AA - Tap Pipe	B	L	W
SWXT23ACG1	4 1/2 IPS	4 1/2 IPS	8.00	9.25	10.67

**TYPE WAT
WELDED V-CONNECTOR**

For Use On TUBE TO TUBE

Aluminum alloy welded type V-Connector for joining a wide range of tubes on a on Bus A-Frame.

Material: Aluminum Alloy



Notes :

- Welding to be done by customer
- Before welding scratch brush connector and conductor contact surface dry, then apply an oxide inhibitor.

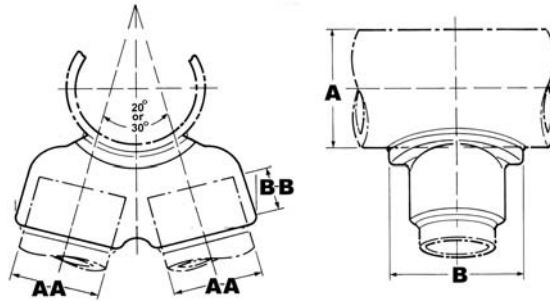

Catalog Number	A	AA	B	BB
WAT20A18A20	3 IPS	2 IPS	5.00	1.00

**TYPE SWAT
WELDED V-CONNECTOR**

For Use On Bus "A" Frame
Connector

Aluminum Alloy streamlined, weld type
A-Frame connector, self shielding at
voltages up to 500kV.
For standard (Schedule 40) and extra
heavy (Schedule 80) Aluminum tube.



Material: Aluminum Alloy

Notes :

- Welding to be done by customer
- Before welding scratch brush connector and conductor contact surface dry, then apply an oxide inhibitor.
- Please contact factory for availability.

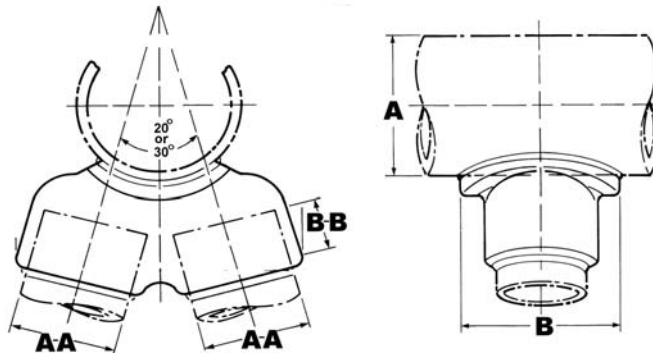

Catalog Number	A - Run Pipe	AA - Tap Pipe	B	BB
SWAT18A15A30	2 IPS	1 IPS	3.00	0.75
SWAT18A16A30	2 IPS	1 1/4 IPS	3.25	1.00
SWAT18A17A-30	2 IPS	1 1/2 IPS	3.50	1.00
SWAT18A18A30	2 IPS	2 IPS	4.00	1.00
SWAT19A16A-30	2 1/2 IPS	1 1/4 IPS	3.25	1.00
SWAT19A17A20	2 1/2 IPS	1 1/2 IPS	3.50	1.00
SWAT19A17A-30	2 1/2 IPS		3.50	1.00
SWAT19A18A30	2 1/2 IPS	2 IPS	4.00	1.00
SWAT19A19A30	2 1/2 IPS	2 1/2 IPS	4.38	1.38
SWAT20A17A-30	3 IPS	1 1/2 IPS	3.50	1.00
SWAT20A18A-30	3 IPS	2 IPS	4.00	1.00
SWAT20A19A20	3 IPS	2 1/2 IPS	4.38	1.38
SWAT20A19A30	3 IPS		4.38	1.38
SWAT20A20A30	3 IPS	3 IPS	5.12	1.38
SWAT21A16A30	3 1/2 IPS	1 1/4 IPS	3.25	1.00
SWAT21A17A30	3 1/2 IPS	1 1/2 IPS	3.50	1.00
SWAT21A18A-30	3 1/2 IPS	2 IPS	4.00	1.00
SWAT21A19A30	3 1/2 IPS	2 1/2 IPS	4.38	1.38
SWAT21A20A30	3 1/2 IPS	3 IPS	5.00	1.38
SWAT21A21A30	3 1/2 IPS	3 1/2 IPS	5.50	1.38
SWAT22A18A30	4 IPS	2 IPS	4.00	1.00

TYPE SWAT
WELDED V-CONNECTOR
 (Continued)



Catalog Number	A - Run Pipe	AA - Tap Pipe	B	BB
SWAT22A19A20	4 IPS	2 1/2 IPS	4.38	1.38
SWAT22A19A30	4 IPS		4.38	1.38
SWAT22A20A30	4 IPS	3 IPS	5.12	1.38
SWAT22A22A30	4 IPS	4 IPS	5.28	1.38
SWAT24A18A30	5 IPS	2 IPS	4.00	1.00
SWAT24A19A30	5 IPS	2 1/2 IPS	4.38	1.38
SWAT24A20A20	5 IPS	3 IPS	5.12	1.38
SWAT24A20A-30	5 IPS		2.12	1.38
SWAT24A21A30	5 IPS	3 1/2 IPS	5.69	1.38
SWAT24A22A30	5 IPS	4 IPS	5.12	1.38
SWAT86A19A30	6 IPS	2 1/2 IPS	4.38	1.38
SWAT86A20A30	6 IPS	3 IPS	5.12	1.38
SWAT86A21A20	6 IPS	3 1/2 IPS	5.88	1.38
SWAT86A21A30	6 IPS		5.88	1.38
SWAT86A22A-30	6 IPS	4 IPS	6.25	1.38

**TYPE SWT75
WELDED T CONNECTOR**

For Use On ANGLE PIPE TO
PIPE T FOR A FRAME

Aluminum Alloy streamlined, weld type
A-Frame connector, self-shielding at
voltages up to 550kV.

Material: Aluminum Alloy

Notes :

- Welding to be done by customer
- Before welding scratch brush connector and conductor contact surface dry, then apply an oxide inhibitor.
- Please contact factory for availability or other angle options.

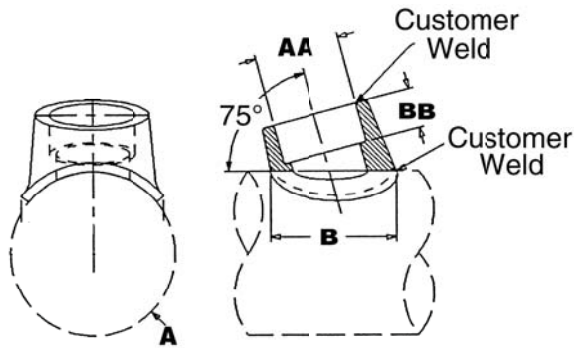

Catalog Number	A - Run Pipe	AA - Tap Pipe	B	BB
SWT18A15A75	2 IPS	1 IPS	2.38	0.75
SWT18A18A75	2 IPS	2 IPS	4.00	1.00
SWT19A17A75	2 1/2 IPS	1 1/2 IPS	3.19	1.00
SWT19A18A75	2 1/2 IPS	2 IPS	4.00	1.00
SWT19A19A75	2 1/2 IPS	2 1/2 IPS	4.00	1.38
SWT20A17A75	3 IPS	1 1/2 IPS	3.19	1.00
SWT20A18A75	3 IPS	2 IPS	4.00	1.00
SWT20A20A75	3 IPS	3 IPS	4.56	1.38
SWT21A16A75	3 1/2 IPS	1 1/4 IPS	2.69	1.00
SWT21A18A75	3 1/2 IPS	2 IPS	4.00	1.00
SWT21A19A75	3 1/2 IPS	2 1/2 IPS	4.00	1.38
SWT21A21A75	3 1/2 IPS	3 1/2 IPS	5.50	1.38
SWT22A17A75	4 IPS	1 1/2 IPS	4.00	1.00
SWT22A18A75	4 IPS	2 IPS	4.12	1.00
SWT22A19A75	4 IPS	2 1/2 IPS	4.00	1.38
SWT22A20A75	4 IPS	3 IPS	4.56	1.38
SWT22A22A75	4 IPS	4 IPS	6.00	1.38
SWT24A19A75	5 IPS	2 1/2 IPS	4.00	1.38
SWT24A20A75	5 IPS	3 IPS	4.56	1.38
SWT24A21A75	5 IPS	3 1/2 IPS	5.50	1.38
SWT24A22A75	5 IPS	4 IPS	6.00	1.38
SWT86A20A75	6 IPS	3 IPS	4.56	1.38
SWT86A21A75	6 IPS	3 1/2 IPS	5.50	1.38
SWT86A22A75	6 IPS	4 IPS	6.00	1.38
SWT86A24A75	6 IPS	5 IPS	6.00	1.38

**TYPE SWT-80
WELDED T-CONNECTOR**

For Use On ANGLE PIPE TO
PIPE T FOR A FRAME

Aluminum Alloy streamlined, weld type
A-Frame connector, self-shielding at
voltages up to 550kV.

Material: Aluminum Alloy



Notes :

- Welding to be done by customer
- Before welding scratch brush connector and conductor contact surface dry, then apply an oxide inhibitor.
- Conductor smaller than 3 inch bus size not recommended for 550kV.

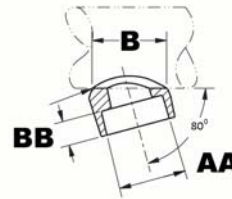
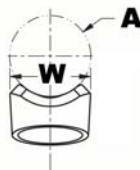

Catalog Number	A - Run Pipe	AA - Tap Pipe	B	BB	W
SWT19A17A80	2 1/2 IPS	1 1/2 IPS	3.19	1.00	2.52
SWT20A18A80	3 IPS	2 IPS	4.00	1.00	2.96
SWT20A19A80	3 IPS	2 1/2 IPS	4.00	1.38	3.80
SWT20A20A80	3 IPS	3 IPS	4.56	1.38	4.50
SWT22A19A80	4 IPS	2 1/2 IPS	4.00	1.38	3.63
SWT22A20A80	4 IPS	3 IPS	4.56	1.38	4.50
SWT24A20A80	5 IPS		4.56	1.38	4.98
SWT86A21A80	6 IPS	3 1/2 IPS	5.50	1.38	5.47

Table of Contents - Aluminum Welded Stud Connectors



Type WXD-AR Expansion Stud to Pipe A-251



Type WXD-AT Expansion Stud to Pipe A-252

**TYPE WXD-AR
EXPANSION STUD
CONNECTOR**

For Use On EXPANSION STUD TO PIPE

Cast aluminum expansion stud connector for joining a wide range of aluminum pipe to equipment pads. Contains high strength aluminum hardware. Unique groove design provides maximum around on all pipes accommodated. Stud element can be bolted to aluminum stud with "PENETROX A"

Material: Aluminum Alloy
Hardware: Aluminum Hardware

Notes :

- Welding to be done by customer
- Before welding scratch brush connector and conductor contact surface dry, then apply an oxide inhibitor.
- Please contact factory for availability.

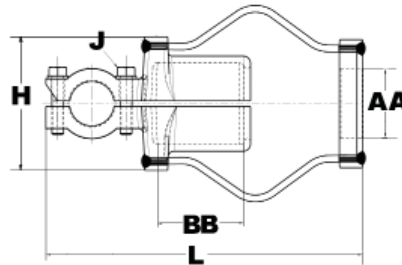
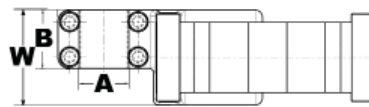
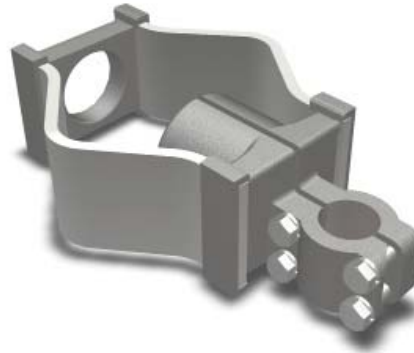

Catalog Number	Stud A	AA	B	BB	Threads per inch	J - Dia.	L	H	W
WXD6819AR12	2	2 1/2 IPS	2.50	3.00	12	1/2	13.55	5.70	4.50

**TYPE WXD-AT
EXPANSION STUD
CONNECTOR**

For Use On EXPANSION STUD TO PIPE

Cast aluminum expansion stud connector for joining a wide range of aluminum pipe to equipment pads. One wrench installation.

Material: Aluminum Alloy
Hardware: Aluminum Hardware

Notes :

- Welding to be done by customer
- Before welding scratch brush connector and conductor contact surface dry, then apply an oxide inhibitor.
- Please contact factory for availability.

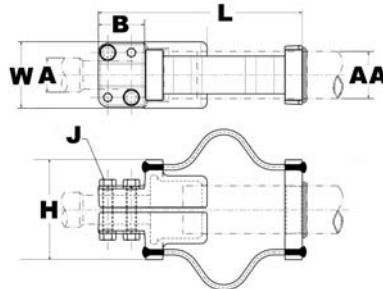

Catalog Number	Stud A	Threads per inch	B	J - Dia.	AA	L	H	W
WXD6718AT12	1-1/2	12	5.75	1/2	2 IPS	11.38	5.26	3.52

Table of Contents - Aluminum Welded End Caps & Grounding Studs

	Type LB-A	A-255
	Type WLB-A Pipe End Plug	A-257
	Type CB-A	A-258
	Type SCB Corona End Bell	A-259
	Type SCBB Corona End Bell (with Set Screws)	A-260
	Type WCB Pipe Grounding Stud	A-261
	Type WG Pipe Grounding Stud	A-262
	Type SWCB-A Pipe Ground Stud with Corona Ball	A-263

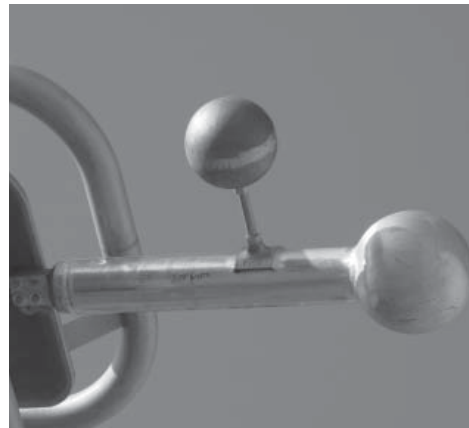
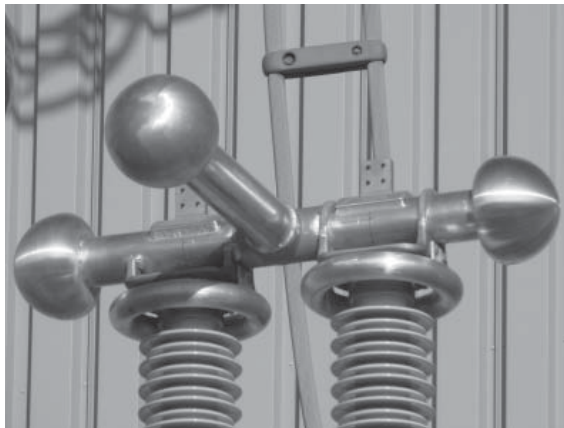

**TYPE LB-A
END CAP**

For Use On PIPE END CAP

Aluminum alloy end cap for aluminum tube. Driven into place for a secure fit. Seals out moisture, reduces electrostatic loss and eliminates hazards created by nesting birds.

Material: Aluminum Alloy
Hardware: Aluminum Hardware

Notes :

- Installation instructions available upon request
- Please contact factory for other sizes, combinations and availability.

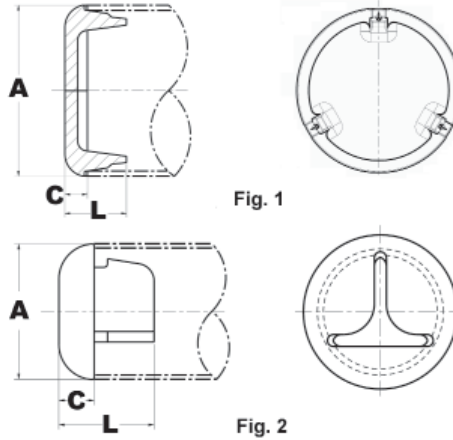

Catalog Number	Al tube Sch 40	Al tube Sch 80	C	L
LB13A	1/2 IPS	N/A	.38	1.25
LB14A	3/4 IPS		.50	1.37
LB15A	1 IPS		.50	1.35
LB16A	1 1/4 IPS		.50	1.35
LB17A	1 1/2 IPS		.50	1.35
LB18A	2 IPS		.88	2.16
LB19A	2 1/2 IPS		.88	2.24
LB20A	3 IPS		.88	2.29
LB21A	3 1/2 IPS		.88	2.33
LB22A	4 IPS		.88	2.22
LB23A	4 1/2 IPS		.88	2.28
LB24A	5 IPS		.88	2.45
LB83A	8 OD		.75	2.28
LB86A	6 IPS		.88	2.57
LB88A	8 IPS		.75	2.28
LB53A	N/A		1/2 IPS	.38
LB54A		3/4 IPS	.50	1.37
LB55A		1 IPS	.50	1.35
LB56A		1 1/4 IPS	.50	1.35

TYPE LB-A
END CAP (Continued)



Catalog Number	Al tube Sch 40	Al tube Sch 80	C	L
LB57A	N/A	1 1/2 IPS	.50	1.35
LB58A		2 IPS	.88	2.16
LB59A		2 1/2 IPS	.88	2.24
LB90A		3 IPS	.88	2.29
LB91A		3 1/2 IPS	.88	2.33
LB92A		4 IPS	.88	2.22
LB94A		5 IPS	.88	2.45
LB96A		6 IPS	.88	2.57

**TYPE WLB-A
WELDED END PLUG**

For Use On BUS TO END CAP

Aluminum weld type end plug for use in shielded EHV or HV applications. For standard (Schedule 40) and extra heavy (Schedule 80) tubing.

Material: Aluminum Alloy

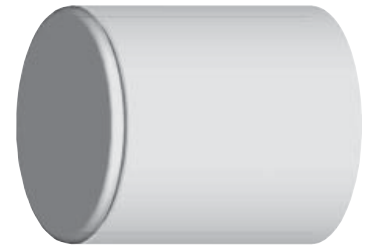

Notes :

- Welding to be done by customer
- Conductor smaller than 3 inch bus size is not recommended for 550kV
- Before welding scratch brush connector and conductor contact surface dry, then apply an oxide inhibitor.
- Please contact factory for other sizes, combinations and availability.

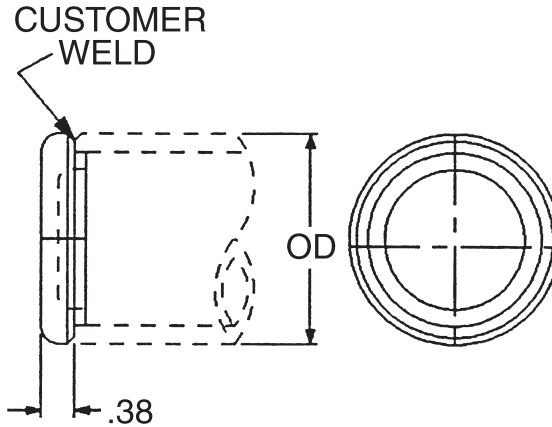

Catalog Number	Al Pipe Sch 40	Al Pipe Sch 80
WLB15A	1 IPS	N/A
WLB16A	1 1/4 IPS	
WLB17A	1 1/2 IPS	
WLB18A	2 IPS	
WLB19A	2 1/2 IPS	
WLB20A	3 IPS	
WLB21A	3 1/2 IPS	
WLB22A	4 IPS	
WLB24A	5 IPS	
WLB86A	6 IPS	
WLB55A	N/A	1 IPS
WLB56A		1 1/4 IPS
WLB57A		1 1/2 IPS
WLB58A		2 IPS
WLB59A		2 1/2 IPS
WLB90A		3 IPS
WLB91A		3 1/2 IPS
WLB92A		4 IPS
WLB94A		5 IPS
WLB96A		6 IPS

**TYPE CB-A
END CAP**

For Use On ALUMINUM PIPE

Aluminum alloy end cap for aluminum tube. Seals out moisture, reduces electrostatic loss and eliminates hazards created by nesting birds.

Material: Aluminum Alloy
Hardware: Aluminum Hardware

Notes :

- Installation instructions available upon request
- Please contact factory for other sizes, combinations and availability.

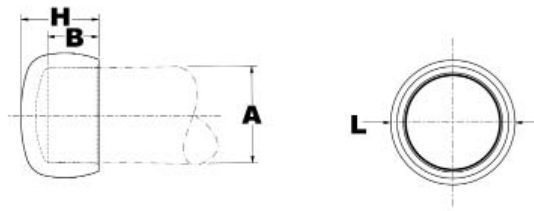

Catalog Number	Al tube	B	L	H
CB15A	1 IPS	0.94	1.59	2.31
CB16A	1 1/4 IPS	1.12	1.91	2.50
CB17A	1 1/2 IPS	1.31	2.06	2.81
CB18A	2 IPS	1.50	2.31	3.38
CB19A	2 1/2 IPS	1.62	2.38	3.81
CB20A	3 IPS	1.83	2.84	4.56
CB21A	3 1/2 IPS	2.00	2.84	4.56
CB22A	4 IPS	2.12	3.13	5.74
CB24A	5 IPS	2.38	3.46	6.98
CB86A	6 IPS	2.75	4.40	8.20

**TYPE SCB
WELDED CORONA BELL**

For Use On CORONA BELL
WELDED

Aluminum Alloy streamlined, self-shielding corona end bells operate at voltages up to 550kV. For standard (Schedule 40) and extra heavy (Schedule 80) tube.

Material: Aluminum Alloy
Hardware: Aluminum Hardware

Notes :

- Welding to be done by customer
- Please contact factory for other sizes, combinations and availability.

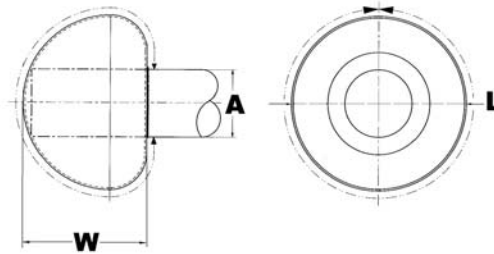

Catalog Number	Al tube (Sch 40 & 80)	W	L
SCB18A	2 IPS	12.00	8.5
SCB19A	2 1/2 IPS		8.5
SCB20A	3 IPS		8.5
SCB21A	3 1/2 IPS		8.5
SCB22A	4 IPS		8.5
SCB24A	5 IPS		8.5
SCB83A	8 OD		8.5
SCB86A	6 IPS		8.5

**TYPE SCBB
END CAP**

For Use On CORONA BELL
(SET SCREW)

Aluminum Alloy streamlined, self-shielding corona end bells operate at voltages up to 550kV. For standard (Schedule 40) and extra heavy (Schedule 80) tube. Bus to Corona Bell connector with set screws for alignment.

Material: Aluminum Alloy
Hardware: Aluminum Hardware

Notes :

- Welding to be done by customer
- Please contact factory for other sizes, combinations and availability.

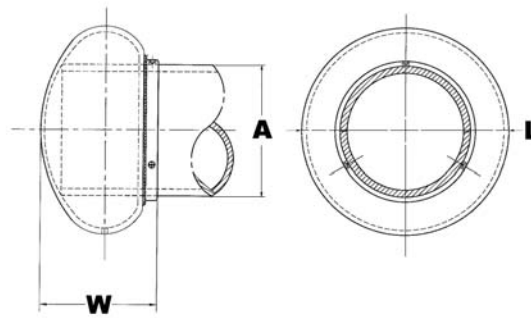

Catalog Number	Al tube (Sch 40 & 80)	W	L
SCBB20A	3 IPS	12.00	9.25
SCBB21A	3 1/2 IPS		9.25
SCBB24A	5 IPS		9.25
SCBB86A	6 IPS		9.25
SCBB88A	8 IPS		9.25

**TYPE WCB
WELDED GROUND STUD**

For Use On BUS TO CORONA
SPHERE

Self-shielding aluminum alloy welded
stud for joining bus to corona sphere.

Material: Aluminum Alloy

Notes :

- Welding to be done by customer
- Before welding scratch brush
connector and conductor contact
surface dry, then apply an oxide
inhibitor.
- Please contact factory for
availability.

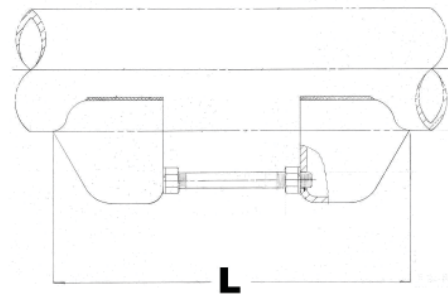
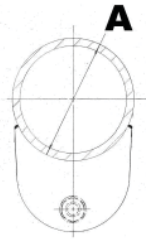

Catalog Number	Al Pipe	L
WCB83ACG6	8 OD	23.75

**TYPE WG
GROUND STUD**

For Use On STUD TO TUBE

Range-taking weldment stud for grounding aluminum tube.

Material: Aluminum Alloy

Notes :

- Welding to be done by customer
- Before welding scratch brush connector and conductor contact surface dry, then apply an oxide inhibitor.
- Please contact factory for availability.

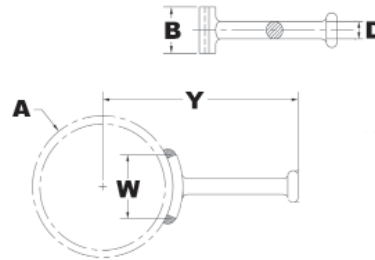

Catalog Number	Al Pipe	B	Y	D	W
WG19A	1 IPS -2 1/2 IPS	3	8.19	0.75	1.32
WG86A	3 IPS -6 IPS	2	10.31	0.75	3.06

**TYPE SWCB-A
WELDED GROUND STUD**

For Use On BUS TO CORONA
SPHERE

Weld type Application : Bus to corona
sphere.

**EHV RATED: SELF-SHIELDING UP
TO 550 kV**

Material: Aluminum Alloy

Notes :

- Welding to be done by customer
- Before welding scratch brush connector and conductor contact surface dry, then apply an oxide inhibitor.
- Please contact factory for availability.

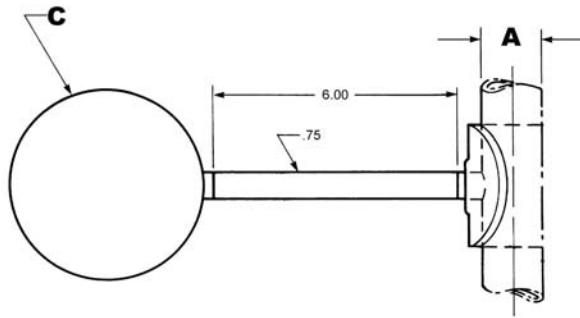
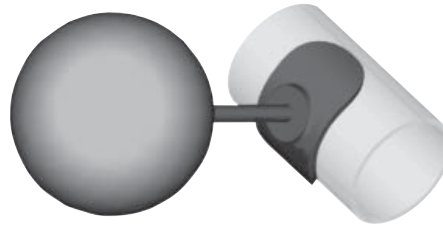

Catalog Number	A-Al Pipe	C
SWCB19A	2 1/2 IPS	9.00
SWCB20A	3 IPS	
SWCB22A	4 IPS	
SWCB23A	4 1/2 IPS	
SWCB24A	5 IPS	
SWCB83A	8 OD	
SWCB86A	6 IPS	
SWCB88A	8 IPS	

Reference Section — Basic Electrical Connection Principles:

Basic Factors:

The basic factors which influence the design and performance of pressure wire connections are as follows:

1. Creep
2. Surface Oxide
3. Corrosion

A fourth factor, known as thermal effects, is also a consideration, but due to the technical nature and length of this topic, it will not be discussed in this publication.

At the outset it should be pointed out that these factors give rise to much more difficult problems in connections involving aluminum conductors than those encountered in copper to copper connections.

Creep (Cold Flow)

Creep is the cold flow of the metal under pressure and it continues until the pressure reduces to a value at which any further creep is negligible. Creep properties depend on the particular metal or alloy and on its hardness; alloys having less creep than pure metals, and harder metals have less creep than soft metals. In a typical connection, the conductors are generally of pure metal and often of soft temper and therefore, subject to considerable creep. In addition, the condition is further exaggerated when aluminum is the conductor as compared to copper, since its creep rate is many times that of copper.

Effect of Creep: Figure 2 shows typical curves of total contact resistance plotted against total contact force. Curve A shows how the contact resistance continually decreases with increasing contact force. When the full contact force F_1 is reached, the contact resistance reaches the low value of R_1 . In general, the full tightening force on a connector greatly exceeds the maximum force for which there is no appreciable creep. Therefore, the force will gradually settle down to a value after which there will be no further significant creep. Fortunately, however, the resistance does not climb back up

along curve A, the tightening curve, but instead it follows a new curve B, the relaxing curve, along which the resistance changes very little until the force relaxes to a value such as F_2 .

Admittedly, the point of “no appreciable creep” is difficult to define. For pure metals, especially in the soft state, there is always some creep, even at very low pressures at room temperature. However, we do know that the pressure required to produce the same creep rate is several times greater for copper than for aluminum. Thus, to permit the same contact force F_2 for aluminum and copper, the contact area A required for aluminum can be expected to be considerably greater than that required for copper. This explains why the contact areas for connectors for aluminum must be considerably greater than for copper and why many light duty connectors for copper are entirely inadequate for aluminum, even when specially plated and when recommended compounds are used on the contact surfaces.

Relaxation: Relaxation of pressure due to creep, or for any other reason, would be a much more difficult factor in a pressure connection were it not for the relationship of contact pressure to contact resistance on the relaxation curve as shown in Figure 2. It is frequently observed that some time after the bolts of a clamp type connector are tightened, the bolt tensions are relaxed appreciably. The question arises as to whether it is necessary to retighten the bolts to the original torque value. In a properly designed connector, retightening is unnecessary since the contact resistance should increase very little due to the relaxation of pressure, as shown by the relaxation curve of Figure 2.

This fact is largely responsible for the successful operation of a compression connector. The application of the compression tool applies very high pressure, establishing very low contact resistance. The removal of

the compression tool releases a very large proportion of this pressure, and creep further relaxes this pressure. Fortunately, the contact resistance increases very little due to this pressure relaxation.

Contact Force: The previous analysis shows that the total contact force largely determines the contact resistance. Thus, to achieve the desired low value of contact resistance, the proper size and number of bolts in a clamp type connector must be supplied, and the compression tool must apply the proper force to a compression connector. In addition, the connector must be designed with sufficient structural strength, contact area, and resilience, to assure that the contact force cannot relax beyond the point where contact resistance begins to rise appreciably, as shown in Figure 2.

Surface Oxide

The contact of pure metallic surfaces cannot be assured in practical connections. Surface contamination must be expected, especially surface oxidation. These surface films are insulators as far as contact resistance is concerned, and they must be broken to achieve metal to metal contact to make an adequate electrical connection. The difficulty of breaking the film depends on the nature of the film, its thickness, and the metal on which it is formed.

Copper oxide is generally broken down by reasonably low values of contact pressure. Unless the copper is badly oxidized, good contact can be obtained with very little or no cleaning.

Silver oxide is even more easily broken down by the contact pressure; and since silver oxide forms less readily at elevated temperatures, silver contact surfaces are preferred over copper when used for high temperatures. For this reason, it is considered good practice to silver plate copper contact surfaces that must operate at temperatures over 200°C .

Reference Section — Basic Electrical Connection Principles:

(continued)

On the other hand, aluminum oxide is a hard, tenacious, high resistance film that forms very rapidly on the surface of aluminum exposed to air. In fact, it is the toughness of this film that gives aluminum its good corrosion resistance. The oxide film that forms after more than a few hours is too thick and tough to permit a low resistance contact without cleaning. The aluminum oxide film is transparent so that even the bright and clean appearance of an aluminum connector is no assurance that the low contact resistance can be attained without cleaning.

In addition to the necessity for cleaning the oxide from aluminum, the surface should be covered with a good connector compound to prevent the oxide from reforming. Common practice is to clean the surface with a wire brush or emery cloth. The compound should be applied immediately after cleaning, or the compound should be put on first and the surface scraped through the compound. Present practice is to scratch brush dry and to apply the compound immediately thereafter. This allows a more thorough job of cleaning the conductor.

Contact Compounds: Petrolatum or No-Oxid are good contact surface compounds for aluminum, but BURNDY® PENETROX™ A, a petroleum type compound containing zinc dust, has the additional advantage of assisting in the breaking down of the contact resistance. How this is accomplished is not certain, but it appears that the zinc particles of PENETROX™ A probably act as current bridges in the breaks in the oxide film. For more complete information about the PENETROX™ line of compounds, refer to the Accessories section of this catalog.

Interstrand Resistance: The high contact resistance due to the oxide on the strands of an aluminum cable may be responsible for a poor distribution of current among

the strands on the cable. Thus, the outer strands may carry much more than their share of the current and overheating of the cable may result. Tests have shown that even on new cable this effect of interstrand resistance can be considerable unless a good contact compound is used. The clamping action tends to break down the oxide and force the compound between the strands. This is particularly true of compression connectors due to the very high unit pressures developed.

The most effective way to break down interstrand resistance of aluminum cable is to use compression connectors filled with a compound having zinc particles. Then, when the end of the cable is inserted in the connector, the compound is forced between the strands where it very effectively breaks down the interstrand resistance upon application of the compressive force.

Plating Aluminum: Plating the contact surfaces of aluminum connectors will prevent the formation of aluminum oxide. Electro-tin, cadmium and zinc platings have been used for this purpose. However, the use of a plated aluminum conductor, does not make it less necessary to scratch brush the aluminum conductor, nor does it reduce the need for a good contact compound. Additional problems are introduced due to the plating on aluminum which render it of very doubtful value over the proper use of base aluminum. This will be more fully discussed later.

Corrosion

The electrical conductivity and mechanical strength of an electrical connection must remain stable under the deteriorating influences of the environment. This deterioration is corrosion. It is the electrolytic action of moisture and other elements of the atmosphere in conjunction with the metals of the connection. If the conductors and connectors are of copper or a corrosion resistant copper

alloy, corrosion is usually a minor factor. However, it is a very vital factor if aluminum is involved.

If moisture can be kept away from the connection, corrosion will not be a factor. The electrical connection of a high voltage splice on insulated cable is generally free from corrosion since the taping may be used to avoid corrosion on bare cable, provided it excludes moisture. It is difficult to get a good tape seal to the conductor itself, especially on stranded cable. If moisture does penetrate the taping, it will not dry out as readily as if the joint were untaped. Various plastic materials are available today for covering low voltage connections or for bare conductor connections on high voltage. Unless such coverings are completely moisture-proof, it is better to rely on installation with a good contact compound, using a connector designed to resist corrosion.

Galvanic Action: Whenever dissimilar metals are in the presence of an electrolyte, a difference in electric potential is developed. One metal becomes the cathode and receives a positive charge. The other becomes the anode and receives a negative charge. When these metals are in contact, an electrical current will flow, as in the case of any short-circuited electric cell. This electrolytic action causes an attack of the anodic metal, leaving the cathodic metal unharmed. The extent of the attack is proportional to the strength of the electrolytic current, which in turn is proportional to the electric potential difference developed.

The magnitude of the potential difference generated between two dissimilar metals can be seen by the position of these metals in the electrolytic series. Figure 3 is such a series. When two metals are in contact in an electrolyte, the one higher up in this series is the anode, the corroded metal, while the one lower is the cathode, the protected metal. The further apart the metals are in this

Reference Section — Basic Electrical Connection Principles: (continued)

series, the greater the electrolytic potential difference, and the greater the attack to the anodic metal.

Note that copper and aluminum are quite far apart in the series, copper being cathodic and aluminum anodic. Hence, when aluminum and copper are in contact in an electrolyte, the aluminum can be expected to be severely attacked.

Crevice Corrosion: Electrolytic attack can also occur between like metals due to a phenomenon known as oxygen concentration cell or crevice corrosion. Since oxygen is necessary for corrosive action, a variation in the concentration of oxygen where a metal is exposed to an electrolyte will generate a difference of potential, and cause a corrosive attack in the oxygen starved area. Thus, since an electrolyte in a deep crevice is freely exposed to the air at the outside, the concentration of oxygen will be greatest at the mouth of the crevice. Then corrosion can be expected to occur in the crevice remote from the surface. Crevice corrosion can be prevented if the crevice is filled with a compound to exclude moisture. Thus, within the contact groove of an aluminum connector containing an aluminum conductor, there will be numerous crevices in which corrosion will take place unless a good connector compound is applied during installation. Copper, being a more noble metal, appears to be much less subject to crevice corrosion.

Corrosion Testing: The effectiveness of an electrical connection to resist corrosion can be tested in the laboratory under conditions designed to greatly accelerate the natural corrosive conditions of actual service. The most widely accepted means is the standard salt spray chamber. In this chamber the specimens are placed in a salt fog made by atomizing a 20% salt solution at 100° F.

BURNDY, as well as other manufacturers and utility companies,

have done a great deal of testing and a considerable area of agreement has been reached. There are, however, minor differences in recommended practices. The problem is concerned with aluminum and aluminum to copper connections since the effect of corrosion on copper to copper connections is far less serious. Let us study the recommended practices.

Aluminum to Aluminum Connections: For joining aluminum to aluminum conductors, there is little disagreement that an aluminum bodied connector is the proper choice, since this obviously eliminates the galvanic corrosion of dissimilar metals. However, even in this case, care must be taken to prevent crevice corrosion and to select an alloy of aluminum for the connector body that is free from cracking due to stress corrosion.

Aluminum to Copper Connections: Similarly, for joining aluminum to copper conductors, an aluminum bodied connector is the best choice since it prevents galvanic corrosion of the aluminum conductor, the most vulnerable element to attack in the connection. Realizing this, BURNDY initiated a research program aimed at finding the best way to make an aluminum connector suitable for joining aluminum to copper conductors.

This led to the evolution of the "Massive Anode Principle" of connector design for joining conductors of dissimilar metal. On the basis of this principle, properly designed, all-aluminum connectors became available for universal use in joining aluminum to aluminum or aluminum to copper conductors.

Massive Anode Principle: By making the aluminum connector massive in comparison to the copper conductor, when the copper conductor emerges from the connector, the electrolytic current density over the exposed face of the aluminum connector is greatly reduced. This is schematically represented in Figure 4. Since the rate

of corrosion is directly related to the current density on the surface of the anodic material, the relatively large face of the aluminum connector will suffer only minor attack.

In addition, because the aluminum connector body is massive in the region where the corrosion occurs, the small loss of metal caused by corrosion is insignificant, even after long periods of service. Furthermore, the connector design should be such that clamping bolts, and areas of high stress which provide structural strength, are not in the regions subject to galvanic attack.

The effectiveness of this theory has been amply demonstrated in salt spray corrosion tests in which the connectors were subject to 1,000 hours in the salt spray fog with only minor corrosive pitting adjacent to the copper conductor, as seen in Figure 5. In addition, the aluminum conductor was completely protected, and the joint resistance remained virtually unchanged. The test involved a wide variety of sizes and types of connectors showing the effectiveness for small service connectors as well as large power connectors. Figure 6 shows a large all aluminum clamp type T connector installed on 3-1/2" diameter copper run and 750 kcmil aluminum tap. The figure shows this connector which was opened up after 1,400 hours of the salt spray test. Note that the contact surfaces are bright and clean and the only evidence is minor pitting along the faces adjacent to the copper.

*It should be emphasized that a good compound should be used on the contact surfaces whether aluminum or copper is used in an aluminum connector.

Position of Conductor: A properly designed aluminum connector for joining aluminum to copper must provide adequate separation between the conductors to prevent electrolytic attack on the aluminum conductor.

Reference Section — Basic Electrical Connection Principles: (continued)

Even then, it is good practice to install the aluminum conductor above the copper conductor if possible. This will prevent pitting of the aluminum conductor due to copper salts being washed over the aluminum.

Plated Aluminum Connectors:

Plating has been used as a means to make an aluminum connector suitable for copper conductor. Such platings as copper, zinc, tin and cadmium have been used. The plating of aluminum is much more critical than plating a more noble metal such as copper. In addition, a preplate, usually of copper or brass, must be applied, thus introducing numerous metals and further possibilities for galvanic corrosion.

To be effective in reducing galvanic corrosion between the copper conductor and the aluminum connector, the plated metal must be closer in the Electrolytic Series to copper than is aluminum. It must therefore, be cathodic to aluminum. Since porosity and minor scratches are always present, galvanic action can be expected in the presence of moisture, resulting in attack of the aluminum under the plating. Corrosion tests reveal attack in the form of a mottled appearance and flaking of the plating.

In addition, the presence of plated metal can cause galvanic attack of the aluminum conductor, thus reducing the protection offered to this conductor in an aluminum connector.

Cleaning and the Use of Compound:

It should be emphasized that when aluminum connectors or conductors are involved, proper cleaning of the aluminum and the use of a good connector compound, such as BURNDY PENETROX™ A, are essential for trouble-free service. BURNDY, as well as other manufacturers, provide the contact grooves with a coating to make it unnecessary to clean the connectors, but in all cases the aluminum conductor should be cleaned by

means such as scratch brushing, and immediately coated with the connector compound.

To simplify the application of the compound, and to assure its use, almost all BURNDY aluminum connectors, except the large clamp type substation connectors, are supplied factory filled with PENETROX™ compound. For the tubular compression connectors, the tubular barrels are sufficiently filled with PENETROX™ and capped. For other types, the contact grooves are filled with PENETROX™ and enclosed in plastic packaging in a process called 'stripsealing'.

Clamp vs. Compression: In general, a compression connection can be expected to be more corrosion resistant than a clamp connection. The high pressures applied to a compression connector more effectively seal the contact against the penetration of moisture. The tubular sleeve of a compression connector has no side openings such as exist in clamp connectors between the clamping members. On the other hand, the clamp connector can be made more corrosion resistant if the conductor grooves conform more closely with the conductor contour. Thus a clamp connector made to accommodate a wide range of conductor sizes cannot be expected to be as corrosion resistant as one designed for one specific conductor size. Nevertheless, the differences in effectiveness of various designs can be minimized if a good contact compound is used.

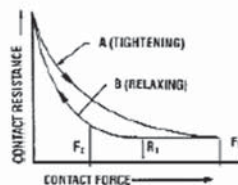

- ✦ LESS NOBLE (ANODIC)
- ↓ Magnesium
- ↓ Magnesium alloys
- ↓ Zinc
- ↓ Aluminum 1100
- ↓ Cadmium
- ↓ Aluminum 2024-T4
- ↓ Steel or Iron
- ↓ Cast Iron
- ↓ Chromium Iron (Active)
- ↓ Ni-Resist
- ↓ Type 304 Stainless (Active)
- ↓ Type 316 Stainless (Active)
- ↓ Lead Tin Solders
- ↓ Lead
- ↓ Tin
- ↓ Nickel (Active)
- ↓ Inconel
- ↓ Brasses
- ↓ Copper
- ↓ Bronzes
- ↓ Copper-Nickel alloys
- ↓ Monel
- ↓ Silver Solder
- ↓ Nickel (Passive)
- ↓ Inconel (Passive)
- ↓ Chromium-Iron (Passive)
- ↓ Type 304 Stainless (Passive)
- ↓ Type 316 Stainless (Passive)
- ↓ Silver
- ↓ Titanium
- ↓ Graphite
- ↓ Gold
- ↓ Platinum
- MORE NOBLE (CATHODIC)

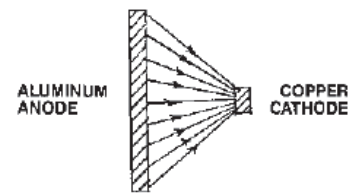

Fig. 4



Fig. 5



Fig. 6

Reference Section — Hardware Data

Recommended Tightening Torque

The hardware used in connectors must be compatible with the connector material, have high mechanical strength and be corrosion resistant.

Copper alloy connectors have hardware made of DURIMUM™, which is the BURNDY trade name for silicon bronze alloy ASTMB99. This material was first introduced by BURNDY in 1927 for use in outdoor construction and today is the standard throughout the industry.

Aluminum connectors generally have aluminum alloy hardware. The bolts are 2024T4 and anodized to resist corrosion. The nuts are 6061T6, which is resistant to corrosion and does not require anodizing. Bolts are lubricated to eliminate galling and to provide consistent clamping forces.

The size material for clamping hardware are selected to provide the required force when tightened to the recommended torque. To reduce or greatly exceed the recommended torque can adversely affect the performance of the connector.

Steel Hardware	
Bolt Size	Recommended Torque (Inch Pounds)
1/4 - 20	80
5/16 - 18	180
3/8 - 16	240
1/2 - 13	480
5/8 - 11	660
3/4 - 10	1050

Aluminum Hardware	
Bolt Size	Recommended Torque (Inch Pounds)
1/2 - 13	300
5/8 - 11	480
3/4 - 10	650

DURIMUM™ (Silicon Bronze) Hexagonal Bolt Data

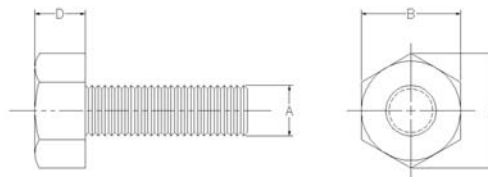

DURIMUM™ (Silicon Bronze) Hardware							
Catalog Number Series*	"A" Bolt Size	"B"	"C"	"D"	Recommended Torque (in-lb)**	Min. Breaking Force (lb)	Min. Shearing Force (lb)
25X__ HEB	1/4 - 20	7/16	.50	.16	80	1,780	990
31X__ HEB	5/16 - 18	1/2	.56	.21	180	2,930	1,640
38X__ HEB	3/8 - 16	9/16	.65	.24	240	4,350	2,430
50X__ HEB	1/2 - 13	3/4	.87	.32	480	7,950	4,460
62X__ HEB	5/8 - 11	15/16	1.08	.40	660	12,700	7,100
75X__ HEB	3/4 - 10	1-1/8	1.30	.48	1050	17,510	10,540

* __ is substituted for bolt length; Consult sales representative for available lengths

**These torque values develop maximum bolt preload
This drawing is based on BURNDY engineering specification

Reference Section — Hardware Data

Recommended Termination Hardware

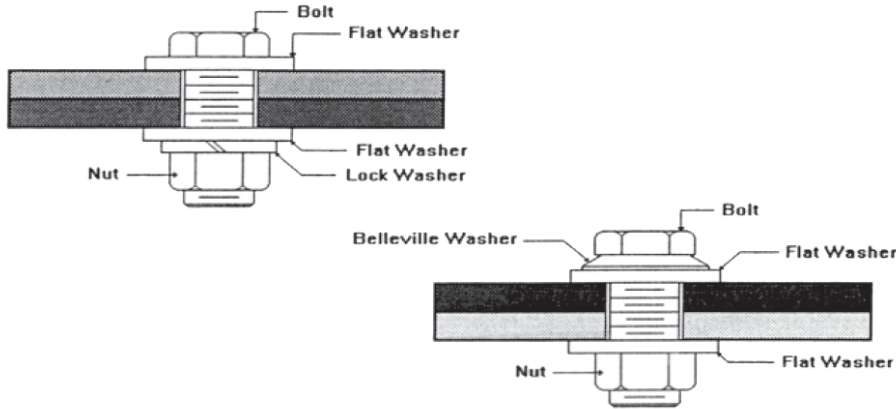

Recommended Tightening Torque per UL486A & UL486B

Table 21 - Tightening torque for screws

Test Conductor Size Installed in Connector		Tightening Torque, N•m (lbf-in)							
		Slotted Head No. 10 and Larger*				Hexagonal Head - External Drive Socket Wrench			
		Slot Width - 1.2mm (.047 in) or Less and Slot Length - 6.4mm (1/4 in.) or less		Slot Width - Over 1.2mm (.047 in) or Slot Length - Over 6.4mm (1/4 in.)		Split-Bolt Connectors		Other Connectors	
AWG or kcmil	mm ²	A	B	A	B	A	B	A	B
30 - 10	.05 - 5.3	1.7 (15)	2.3 (20)	2.8 (25)	4.0 (35)	7.3 (65)	9.0 (80)	6.8 (60)	8.5 (75)
8	8.4	2.3 (20)	2.8 (25)	3.4 (30)	4.5 (40)	7.3 (65)	9.0 (80)	6.8 (60)	8.5 (75)
6 - 4	13.2 - 21.2	2.8 (25)	4.0 (35)	4.0 (35)	5.1 (45)	15.3 (135)	18.6 (165)	10.2 (90)	12.4 (110)
3	26.7	2.8 (25)	4.0 (35)	4.5 (40)	5.6 (50)	25.4 (225)	31.1 (275)	14.1 (125)	16.9 (150)
2	33.6	3.4 (30)	4.5 (40)	4.5 (40)	5.6 (50)	25.4 (225)	31.1 (275)	14.1 (125)	16.9 (150)
1	42.4	-	-	4.5 (40)	5.6 (50)	25.4 (225)	31.1 (275)	14.1 (125)	16.9 (150)
1/0 - 2/0	53.5 - 67.4	-	-	4.5 (40)	5.6 (50)	35.6 (315)	43.5 (385)	16.9 (150)	20.3 (180)
3/0 - 4/0	85.0 - 107.2	-	-	4.5 (40)	5.6 (50)	45.2 (400)	56.5 (500)	22.6 (200)	28.2 (250)
250 - 350	127 - 177	-	-	4.5 (40)	5.6 (50)	62.1 (550)	73.4 (650)	28.2 (250)	36.7 (325)
400	203	-	-	4.5 (40)	5.6 (50)	76.3 (675)	93.2 (825)	28.2 (250)	36.7 (325)
500	253	-	-	4.5 (40)	5.6 (50)	76.3 (675)	93.2 (825)	33.9 (300)	42.4 (375)
600 - 750	304 - 380	-	-	4.5 (40)	5.6 (50)	90.4 (800)	113.0 (1000)	33.9 (300)	42.4 (375)
800 - 1000	406 - 508	-	-	4.5 (40)	5.6 (50)	111.7 (900)	124.3 (1100)	45.2 (400)	56.5 (500)
1250 - 2000	635 - 1000	-	-	-	-	111.7 (900)	124.3 (1100)	56.5 (500)	67.8 (600)

* For values of slot width or length not corresponding to those specified, select the largest torque value associated with the conductor size. Slot width is the nominal design value. Slot length shall be measured at the bottom of the slot.

Reference Section — Hardware Data

Recommended Tightening Torque per UL486A & UL486B

Table 22 - Tightening torque for slotted head screws smaller than No. 10 intended for use with 8 AWG (8.4 mm²) or smaller conductors

Slot Length of Screw*		Tightening Torque, N•m (lbf-in)			
		Slot Width of Screw Smaller than 1.2 mm (.047 in.) ^b		Slot Width of Screw 1.2mm (.047 in.) and larger**	
mm	inch	A	B	A	B
Less than 4	Less than 5/32	0.68 (6)	0.79 (7)	0.79 (7)	1.0 (9)
4	5/32	0.68 (6)	0.79 (7)	1.1 (10)	1.4 (12)
4.8	3/16	0.68 (6)	0.79 (7)	1.1 (10)	1.4 (12)
5.6	7/32	0.68 (6)	0.79 (7)	1.1 (10)	1.4 (12)
6.4	1/4	0.79 (7)	1.0 (9)	1.1 (10)	1.4 (12)
7.1	9/32	-	-	1.4 (12)	1.7 (15)
Above 7.1	Above 9/32	-	-	1.8 (16)	2.3 (20)

* For slot lengths of intermediate values, select torques pertaining to next shorter slot length.

Also see Table 21 for screws with multiple tightening means.

Slot length shall be measured at the bottom of the slot.

** Slot width is the nominal design value

Recommended Tightening Torque per UL486A & UL486B

Table 23 - Tightening torque for screws with recessed allen or square drives

Socket Width Across Flats*		Tightening Torque, N•m (lbf-in)	
mm	inch	A	B
3.2	1/8	4.0 (35)	5.1 (45)
4.0	5/32	9.0 (80)	11.3 (100)
4.8	3/16	11.3 (100)	13.6 (120)
5.6	7/32	13.6 (120)	16.9 (150)
6.4	1/4	16.9 (150)	25.4 (225)
7.9	5/16	25.4 (225)	33.9 (300)
9.5	3/8	33.9 (300)	45.2 (400)
12.7	1/2	45.2 (400)	56.6 (500)
14.3	9/16	56.6 (500)	67.8 (600)

* See Table 21 for screws with multiple tightening means

Reference Section — Recommended Clamping on Bolted Connectors:

When installing a bolted connector, an appropriate sequence needs to be followed.

INSTALLATION INSTRUCTIONS:

1. Nuts need to be tightened up to 30% of expected torque.
2. A check needs to be done to ensure the clamping elements are even.

Even clamping elements

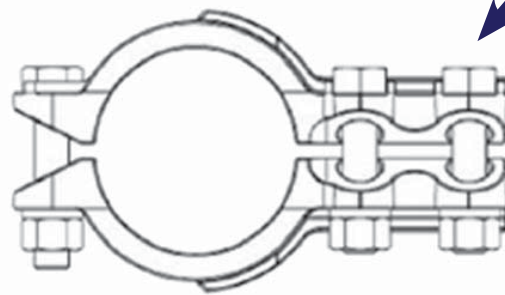

Tightened up to 30%

3. Tightening has to follow a sequence (1-6) as shown below. As a general rule, the torque has to be applied to the nut. For ease of installation most connectors are designed for one wrench installation. A torque wrench is recommended when tightening the nut to ensure the proper torque is applied.

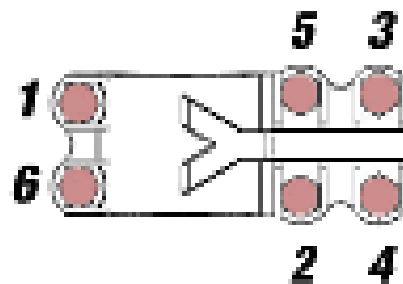

BURNDY offers two sizes of professional grade torque wrenches, catalog number **BTW30150** to be used on connectors requiring 30-150 in-lbs., and the **BTW150750**, designed for 150-750 in-lbs. These micro-adjustable "click-type" torque wrenches feature an easy-to-read scale that can be easily matched to the recommended torque of each of our mechanical connector products. Calibration traceable to N.I.S.T.

Reference Section — Cable Data

COPPER TUBE (BUS)

Size of Tube IPS	Diameter of Tube (Inches)		Wall Thickness (Inches)
	Outside	Inside	
STANDARD PIPE SIZES			
1/4"	0.540	0.375	0.082
3/8"	0.675	0.494	0.090
1/2"	0.840	0.625	0.107
3/4"	1.050	0.822	0.114
1"	1.315	1.062	0.126
1-1/4"	1.660	1.368	0.146
1-1/2"	1.900	1.600	0.150
2"	2.375	2.062	0.156
2-1/2"	2.875	2.500	0.187
3"	3.500	3.062	0.219
3-1/2"	4.000	3.500	0.250
4"	4.500	4.000	0.250
4-1/2"	5.000	4.500	0.250
5"	5.563	5.063	0.250
6"	6.625	6.125	0.250
EXTRA HEAVY PIPE SIZES			
1/4"	0.540	0.294	0.123
3/8"	0.675	0.421	0.127
1/2"	0.840	0.542	0.149
3/4"	1.050	0.736	0.157
1"	1.315	0.951	0.182
1-1/4"	1.660	1.272	0.194
1-1/2"	1.900	1.494	0.203
2"	2.375	1.933	0.221
2-1/2"	2.875	2.315	0.280
3"	3.500	2.892	0.304
3-1/2"	4.000	3.358	0.321
4"	4.500	3.818	0.341
4-1/2"	5.000	4.250	0.375
5"	5.563	4.813	0.375
6"	6.625	5.751	0.437

Size of Tube IPS	Diameter of Tube (Inches)		Wall Thickness (Inches)
	Outside	Inside	
DOUBLE EXTRA HEAVY PIPE SIZES			
1/2"	0.840	0.252	0.294
3/4"	1.050	0.434	0.308
1"	1.315	0.599	0.358
1-1/4"	1.660	0.896	0.382
1-1/2"	1.900	1.100	0.400
2"	2.375	1.503	0.436
2-1/2"	2.875	1.771	0.552
3"	3.500	2.300	0.600
3-1/2"	4.000	2.728	0.636
4"	4.500	3.152	0.674
4-1/2"	5.000	3.580	0.710
5"	5.563	4.063	0.750
6"	6.625	4.897	0.864

Tube dimensions (excepting wall thickness of double extra heavy) taken from A.S.T.M. Specification B42-33.

Tubular values based on a density of 0.322 pound per cubic inch.

* Conductivity of 98% I.A.C.S. at 20° C or 68° F

Reference Section — Cable Data

SOLID COPPER WIRE (ASTM B1, B2, & B3)

Size AWG (Solid)	Wire Dia (Inch)	Hard Drawn	Medium Drawn	Soft Drawn
		Normal Breaking Load (Pounds)	Minimum Breaking Load (Pounds)	Elongation in 10 in. % Min.
18	.040	85.8	67.6	25
17	.045	107.5	84.7	25
16	.050	135.2	106.2	25
15	.057	170.0	133.0	25
14	.064	213.8	166.6	25
13	.071	268.2	208.0	25
12	.080	337.0	261.6	25
11	.090	422.5	327.6	25
10	.101	529.2	410.4	25
9	.114	661.0	514.2	30
8	.128	826.0	643.9	30
7	.144	1,030.0	806.6	30
6	.162	1,280.0	1,010.0	30
5	.181	1,591.0	1,265.0	30
4	.204	1,970.0	1,584.0	30
3	.229	2,439.0	1,984.0	30
2	.257	3,003.0	2,450.0	30
1	.289	3,688.0	3,024.0	30
1/0	.324	4,519.0	3,730.0	35
2/0	.364	5,518.0	4,599.0	35
3/0	.409	6,722.0	5,667.0	35
4/0	.460	8,143.0	6,980.0	35

COMPACT STRANDED COPPER CABLE (ASTM SPEC. B496)

Conductor Size		Number of Wires	Conductor Dia (in)
KCMIL	AWG		
1000		61 ¹	1.060
900		61 ¹	0.999
800		61 ¹	0.938
750		61 ¹	0.908
700		61 ¹	0.877
650		61 ¹	0.845
600		61 ¹	0.813
550		61 ¹	0.775
500		37 ²	0.736
450		37 ²	0.700
400		37 ²	0.659
350		37 ²	0.616
300		37 ²	0.570
250		37 ²	0.520
	4/0	19 ³	0.475
	3/0	19 ³	0.423
	2/0	19 ³	0.376
	1/0	19 ³	0.336
	1	19 ³	0.299
	2	7	0.268
	4	7	0.213
	6	7	0.169
	8	7	0.134

¹ 58 Wires Minimum

² 35 Wires Minimum

³ 18 Wires Minimum

Reference Section — Cable Data

STRANDED COPPER WIRE (ASTM B8 EXCLUDING BREAKING LOADS)

Size		A.S.T.M. Strandings			Hard Drawn	Medium Drawn	Soft Drawn
Stranded		Class	No. of Wires	Cable Diameter (Inches)	Minimum Breaking Load (Pounds)		
Circular Mils	AWG						
1,022	20	B	7	0.036	50.0	40.67	32.1
1,624	18	B	7	0.045	79.0	63.91	51.0
2,583	16	B	7	0.057	124.7	100.4	81.1
4,107	14	B	7	0.072	197.1	157.7	124.2
6,530	12	B	7	0.091	311.1	247.7	197.5
10,380	10	B	7	0.116	491.7	388.9	314.0
13,090	9	B	7	0.130	618.2	487.4	395.9
16,510	8	B	7	0.146	777.2	610.7	499.2
20,820	7	B	7	0.164	977.1	765.2	629.5
26,250	6	B	7	0.184	1,288.0	958.6	793.8
33,100	5	B	7	0.206	1,542.0	1,201.0	1,001.0
41,740	4	AA	3	0.254	1,879.0	1,465.0	1,213.0
41,740	4	B&A	7	0.232	1,938.0	1,505.0	1,262.0
52,630	3	AA	3	0.285	2,359.0	1,835.0	1,530.0
52,630	3	B&A	7	0.260	2,433.0	1,885.0	1,592.0
66,370	2	AA	3	0.320	2,913.0	2,299.0	1,929.0
66,370	2	B&A	7	0.292	3,045.0	2,361.0	2,007.0
83,690	1	AA	3	0.360	3,621.0	2,879.0	2,432.0
83,690	1	A	7	0.328	3,804.0	2,958.0	2,432.0
83,690	1	B	19	0.332	3,899.0	3,037.0	2,531.0
105,500	1/0	A&A	7	0.368	4,752.0	3,705.0	3,067.0
105,500	1/0	-	12	0.390	4,841.0	3,755.0	3,191.0
105,500	1/0	B	19	0.373	4,901.0	3,805.0	3,191.0
133,100	2/0	A&A	7	0.414	5,926.0	4,640.0	3,867.0
133,100	2/0	-	12	0.438	6,048.0	4,703.0	3,867.0
133,100	2/0	B	19	0.419	6,152.0	4,765.0	4,024.0
167,800	3/0	A&A	7	0.464	7,366.0	5,812.0	4,876.0
167,800	3/0	-	12	0.492	7,556.0	5,890.0	4,876.0
167,800	3/0	B	19	0.470	7,698.0	5,970.0	5,074.0
211,600	4/0	A&A	7	0.522	9,154.0	7,278.0	6,149.0
211,600	4/0	-	12	0.522	9,483.0	7,378.0	6,149.0
211,600	4/0	B	19	0.528	9,617.0	7,479.0	6,149.0

Reference Section — Cable Data

STRANDED COPPER WIRE (ASTM B8 EXCLUDING BREAKING LOADS continued)

Size	A.S.T.M. Strandings			Hard Drawn	Medium Drawn	Soft Drawn
Circular Mils	Class	No. of Wires	Cable Diameter (Inches)	Minimum Breaking Load (Pounds)		
250 kcmil	AA	12	0.600	11,130	8,717	7,265
250 kcmil	A	19	0.574	11,360	8,986	7,265
250 kcmil	B	37	0.575	11,560	8,952	7,559
300 kcmil	AA	12	0.657	13,170	10,390	8,718
300 kcmil	A	19	0.628	13,510	10,530	8,718
300 kcmil	B	37	0.630	13,870	10,740	9,071
350 kcmil	AA	12	0.710	15,140	12,040	10,170
350 kcmil	A	19	0.679	15,590	12,200	10,170
350 kcmil	B	37	0.681	16,060	12,450	10,580
400 kcmil	A&AA	19	0.726	17,810	13,950	11,620
400 kcmil	B	37	0.728	18,320	14,140	11,620
450 kcmil	AA	19	0.770	19,750	15,590	13,080
450 kcmil	B&A	37	0.772	20,450	15,900	13,080
500 kcmil	AA	19	0.811	21,950	17,320	14,530
500 kcmil	B&A	37	0.813	22,510	17,550	14,530
600 kcmil	A&AA	37	0.891	27,020	21,060	17,440
600 kcmil	B	61	0.893	27,530	21,350	18,140
700 kcmil	AA	37	0.963	31,170	24,410	20,340
700 kcmil	B&A	61	0.964	31,820	24,740	20,340
750 kcmil	AA	37	0.997	33,400	26,150	21,790
750 kcmil	B&A	61	0.998	34,090	26,510	21,790
800 kcmil	AA	37	1.029	35,120	27,710	23,250
800 kcmil	B&A	61	1.031	36,360	28,270	23,250
900 kcmil	AA	37	1.092	39,510	31,170	26,150
900 kcmil	B&A	61	1.094	40,520	31,590	26,150
1000 kcmil	AA	37	1.151	43,830	34,400	29,060
1000 kcmil	B&A	61	1.152	45,030	35,100	29,060
1250 kcmil	A	61	1.288	55,670	43,590	36,320
1250 kcmil	B	91	1.289	56,280	43,880	36,320
1500 kcmil	A	61	1.411	65,840	51,950	43,590
1500 kcmil	B	91	1.412	67,540	52,650	43,590
1750 kcmil	A	91	1.526	77,930	61,020	50,850
1750 kcmil	B	127	1.526	78,800	61,430	50,850
2000 kcmil	A	91	1.630	87,790	69,270	58,120
2000 kcmil	B	127	1.632	90,050	70,210	58,120

Reference Section — Cable Data

FLEXIBLE COPPER STRANDED CABLE

Conductor Size kcmil or B & S G (AWG)	# Strands	Strand Diameter	Nominal Diameter	Class
8	41	.0201	.156	I
8	49	.0184	.166	G
8	133	.0111	.167	H
8	168	.010	.157	K
8	420	.0063	.162	M
7	49	.0206	.185	G
7	52	.0201	.185	I
7	133	.0125	.188	H
7	210	.010	.179	K
7	532	.0063	.196	M
6	49	.0231	.208	G
6	63	.0201	.207	I
6	133	.0140	.210	H
6	266	.010	.210	K
6	665	.0063	.215	M
5	49	.0260	.234	G
5	84	.0201	.235	I
5	133	.0158	.237	H
5	336	.010	.235	K
5	836	.0063	.240	M
4	49	.0292	.263	G
4	105	.0201	.263	I
4	133	.0177	.266	.H
4	420	.010	.272	K
4	1064	.0063	.269	M
3	49	.0328	.295	G
3	133	.0199	.299	I
3	133	.0201	.291	H
3	532	.010	.304	K
3	1323	.0063	.305	M
2	49	.0368	.331	G
2	133	.0223	.335	I
2	161	.0201	.319	H
2	665	.010	.338	K
2	1666	.0063	.337	M
1	133	.0251	.377	G
1	210	.0201	.367	I
1	259	.018	.378	H
1	836	.010	.397	K
1	2107	.0063	.376	M

Conductor Size kcmil or B & S G (AWG)	# Strands	Strand Diameter	Nominal Diameter	Class
1/0	133	.0282	.423	I
1/0	259	.0202	.424	G
1/0	266	.0201	.441	H
1/0	1064	.010	.451	K
1/0	2646	.0063	.423	M
2/0	133	.0316	.474	G
2/0	259	.0227	.477	I
2/0	342	.0201	.500	H
2/0	1323	.010	.470	K
2/0	3325	.0063	.508	M
3/0	133	.0355	.533	G
3/0	259	.0255	.536	I
3/0	418	.0201	.549	H
3/0	1666	.010	.533	K
3/0	4256	.0063	.576	M
4/0	133	.0399	.599	G
4/0	259	.0286	.601	I
4/0	532	.0201	.613	H
4/0	2107	.010	.627	K
4/0	5320	.0063	.645	M
250	259	.0311	.650	G
250	427	.0242	.653	I
250	637	.0201	.682	.H
250	2499	.010	.682	K
250	6384	.0063	.713	M
300	259	.0340	.714	G
300	427	.0265	.716	I
300	735	.0201	.737	H
300	2989	.010	.768	K
300	7581	.0063	.768	M
350	259	.0368	.773	G
350	427	.0286	.772	I
350	882	.0201	.800	H
350	3458	.010	.809	K
350	8806	.0063	.825	M
400	259	.0393	.825	G
400	427	.0306	.826	I
400	980	.0201	.831	H
400	3990	.010	.878	K
400	10101	.0063	.901	M

Reference Section — Cable Data

FLEXIBLE COPPER STRANDED CABLE (continued)

Conductor Size kcmil or B & S G (AWG)	# Strands	Strand Diameter	Nominal Diameter	Class
450	259	.0417	.876	I
450	427	.0325	.878	G
450	1127	.0201	.894	H
450	4522	.010	.933	K
450	11396	.0063	.940	M
500	259	.0439	.922	G
500	427	.0342	.923	I
500	1225	.0201	.941	H
500	5054	.010	.988	K
500	12691	.0063	.997	M
600	427	.0375	1.013	G
600	703	.0292	1.022	I
600	1470	.0201	1.027	H
600	5985	.010	1.125	K
600	14945	.0063	1.084	M
700	427	.0405	1.094	G
700	703	.0316	1.106	I
700	1729	.0201	1.194	H
700	6916	.010	1.207	K
700	17507	.0063	1.183	M
800	427	.0433	1.169	G
800	703	.0337	1.180	I
800	1995	.0201	1.290	H
800	7980	.010	1.305	K
800	20069	.0063	1.256	M
900	427	.0459	1.239	G
900	703	.0358	1.253	I
900	2261	.0201	1.372	H
900	9065	.010	1.323	K
900	22631	.0063	1.331	M
1000	427	.0484	1.307	G
1000	703	.0377	1.320	I
1000	2527	.0201	1.427	H
1000	10101	.010	1.419	K
1000	25193	.0063	1.404	M

Reference Section — Cable Data

ALUMINUM TUBE

Size of Tube IPS	Diameter of Tube (Inches)		Wall Thickness (Inches)
	Outside	Inside	
STANDARD PIPE SIZES			
1/4"	0.540	0.364	0.088
3/8"	0.675	0.493	0.091
1/2"	0.840	0.622	0.109
3/4"	1.050	0.824	0.113
1"	1.315	1.049	0.133
1-1/4"	1.660	1.380	.0140
1-1/2"	1.900	1.610	0.145
2"	2.375	2.067	0.154
2-1/2"	2.875	2.469	0.203
3"	3.500	3.068	0.213
3-1/2"	4.000	3.548	0.226
4"	4.500	4.026	0.237
4-1/2"	5.000	4.506	0.247
5"	5.563	5.047	0.258
6"	6.625	6.065	0.280
EXTRA HEAVY PIPE SIZES			
1/4"	0.540	0.302	0.119
3/8"	0.675	0.423	0.126
1/2"	0.840	0.546	0.147
3/4"	1.050	0.742	0.154
1"	1.315	0.957	0.179
1-1/4"	1.660	1.278	0.191
1-1/2"	1.900	1.500	0.200
2"	2.375	1.939	0.218
2-1/2"	2.875	2.323	0.276
3"	3.500	2.900	0.300
3-1/2"	4.000	3.364	0.318
4"	4.500	3.826	0.337
4-1/2"	5.000	4.290	0.355
5"	5.563	4.813	0.375
6"	6.625	5.761	0.432

Reference Section — Cable Data

ALUMINUM 1350 CABLE BARE-CLASSES AA AND A - Hard Drawn

Cable Code Word	Size (circular mils or AWG)	Copper Equivalent based on equal D.C. resistance, Cu 97% Al 61%	No. of Wires	Cable Dia. (inches)	Ultimate Strength (pounds)
Peachbell	6	8	7	0.184	528
Rose	4	6	7	0.232	826
Lily	3	5	7	0.260	1022
Iris	2	4	7	0.292	1266
Pansy	1	3	7	0.328	1537
Poppy	1/0	2	7	0.368	1865
Aster	2/0	1	7	0.414	2350
Phlox	3/0	1/0	7	0.464	2845
Oxlip	4/0	2/0	7	0.522	3590
Daisy	266800	3/0	7	0.586	4525
Laurel	266800	3/0	19	0.593	4800
Tulip	336400	4/0	19	0.666	5940
Canna	397500	250000	19	0.724	6880
Cosmos	477000	300000	19	0.793	8090
Syringa	477000	300000	37	0.795	8600
Dahlia	556500	350000	19	0.856	9440
Mistletoe	556500	350000	37	0.858	9830
Orchid	636000	400000	37	0.918	11240
Violet	715500	450000	37	0.974	12640
Nasturtium	715500	450000	61	0.975	13150
Arbutus	795000	500000	37	1.026	13770
Lilac	795000	500000	61	1.028	14330
Anemone	874500	550000	37	1.077	14830
Crocus	874500	550000	61	1.078	15760
Magnolia	954000	600000	37	1.124	16180
Goldenrod	954000	600000	61	1.126	16860
Bluebell	1033500	650000	37	1.170	17530
Larkspur	1033500	650000	61	1.172	18260
Marigold	1113000	700000	61	1.216	19660
Narcissus	1272000	800000	61	1.300	22000
Carnation	1431000	900000	61	1.379	24300
Coreopsis	1590000	1000000	61	1.454	27000
Dogwood	1590000	1000000	91	1.454	28100

Reference Section — Cable Data

ALUMINUM 1350 CABLE BARE-CLASS B

Size (circular mils or AWG)	Copper Equivalent based on equal D.C. resistance, Cu 97% Al 61%	No. of Wires	Cable Dia. (inches)	Ultimate Strength (pounds) Hard Drawn	Minimum Ultimate Strength (pounds) 3/4 Hard	Minimum Ultimate Strength (pounds) Inter Temper
250000	157300	37	0.575	4860	3338	2946
300000	188800	37	0.629	5831	4005	3534
350000	220200	37	0.681	6680	4673	4123
400000	251500	37	0.728	7352	5341	4713
450000	283000	37	0.772	8110	6007	5301
500000	314500	37	0.813	9012	6675	5890
550000	346000	61	0.855	10490	7344	6480
600000	377000	61	0.893	11450	8010	7068
650000	409000	61	0.929	11940	8678	7657
700000	440000	61	0.964	12860	9346	8247
750000	472000	61	0.998	13510	10010	8835
800000	503000	61	1.031	14410	10680	9424
900000	566000	61	1.094	15900	12010	10600
1000000	629000	61	1.152	17670	13350	11780
1100000	692000	91	1.209	20210	14680	12950
1200000	755000	91	1.263	21630	16020	14130
1250000	786000	91	1.289	22530	16690	14720
1300000	818000	91	1.315	23430	17350	15310
1400000	880000	91	1.364	24750	18700	16500
1500000	943000	91	1.412	26500	20020	17670
1600000	1006000	127	1.459	28840	21360	18850
1700000	1069000	127	1.504	30630	22690	20020
1750000	1101000	127	1.526	31530	23350	20610
1800000	1132000	127	1.548	32450	24030	21210
1900000	1195000	127	1.590	33570	25360	22380
2000000	1258000	127	1.632	35340	26700	23560
2500000	1570000	127	1.824	43300	33380	29460
3000000	1890000	169	1.998	53010	40050	35340
3500000	2200000	169	2.158	60610	46730	41230

Reference Section — Cable Data

ACSR

Cable Code Word	Size (circular mils or AWG)	No. Alum Strands	No. Steel Strands	Complete Cable Dia. (inches)	Steel Core Dia. (inches)	Copper Equivalent based on equal D.C. resistance, Cu 97% Al 61%	Ultimate Strength (pounds)
Turkey	6	6	1	0.198	0.0661	8	1170
Thrush	5	6	1	0.223	0.0743	7	1460
Swan	4	6	1	0.250	0.0834	6	1830
Swanate	4	7	1	0.257	0.1029	6	2288
Swallow	3	6	1	0.281	0.0937	5	2250
Sparrow	2	6	1	0.316	0.1052	4	2790
Sparate	2	7	1	0.325	0.1299	4	3525
Robin	1	6	1	0.355	0.1182	3	3480
Raven	1/0	6	1	0.398	0.1327	2	4280
Quail	2/0	6	1	0.447	0.1490	1	5345
Pigeon	3/0	6	1	0.502	0.1672	1/0	6675
Penguin	4/0	6	1	0.563	0.1878	2/0	8420
Waxwing	266800	18	1	0.609	0.1217	3/0	7100
Owl	266800	26	7	0.633	0.2109	3/0	9645
Partridge	266800	26	7	0.642	0.2364	3/0	11250
Ostrich	300000	26	7	0.680	0.2505	188700	12650
Merlin	336400	18	1	0.684	0.1367	4/0	8950
Linnet	336400	26	7	0.721	0.2655	4/0	14050
Oriole	336400	30	7	0.741	0.3177	4/0	17040
Chickadee	397500	18	1	0.743	0.1486	250000	10400
Brant	397500	24	7	0.771	0.2575	250000	14690
Ibis	397500	26	7	0.783	0.2883	250000	16190
Lark	397500	30	7	0.806	0.3453	250000	19980
Pelican	477000	18	1	0.814	0.1628	300000	12300
Flicker	477000	24	7	0.846	0.2820	300000	17200
Hawk	477000	26	7	0.858	0.3162	300000	19430
Hen	477000	30	7	0.883	0.3783	300000	23300
Parakeet	556500	24	7	0.914	0.3045	350000	19850
Dove	556500	26	7	0.927	0.341	350000	22400
Eagle	556500	30	7	0.953	0.409	350000	27200
Peacock	605000	24	7	0.953	0.318	380500	21500
Squab	605000	26	7	0.966	0.356	380500	24100
Teal	605000	30	19	0.994	0.426	380500	30000
Rook	636000	24	7	0.977	0.326	400000	22600
Grosbeak	636000	26	7	0.990	0.365	400000	25000
Egret	636000	30	19	1.019	0.437	400000	31500
Flamingo	666600	24	7	1.000	0.333	419000	23700
Crow	715500	54	7	1.036	0.345	450000	26300
Starling	715500	26	7	1.051	0.387	450000	28100
Redwing	715500	30	19	1.081	0.463	450000	34600
Condor	795000	54	7	1.093	0.364	500000	28500

Reference Section — Cable Data

ACSR (continued)

Cable Code Word	Size (circular mils or AWG)	No. Alum Strands	No. Steel Strands	Complete Cable Dia. (inches)	Steel Core Dia. (inches)	Copper Equivalent based on equal D.C. resistance, Cu 97% Al 61%	Ultimate Strength (pounds)
Drake	795000	26	7	1.108	0.408	500000	31200
Mallard	795000	30	19	1.140	0.489	500000	38400
Crane	874500	54	7	1.146	0.382	550000	31400
Canary	900000	54	7	1.162	0.387	566000	32300
Cardinal	954000	54	7	1.196	0.399	600000	34200
Curlew	1033500	54	7	1.246	0.415	650000	37100
Finch	1113000	54	19	1.293	0.431	700000	40200
Pheasant	1272000	54	19	1.382	0.461	800000	44800
Plover	1431000	54	19	1.465	0.489	900000	50400
Falcon	1590000	54	19	1.545	0.515	100000	56000

HIGH STRENGTH ACSR

Cable Code Word	Size (circular mils or AWG)	No. Alum Strands	No. Steel Strands	Complete Cable Dia. (inches)	Steel Core Dia. (inches)	Copper Equivalent based on equal D.C. resistance, Cu 97% Al 61%	Ultimate Strength (pounds)
Grouse	80000	8	1	0.367	0.1670	50310	5200
Petrel	101800	12	7	0.461	0.2763	64160	9860
Minorca	110800	12	7	0.481	0.2883	69700	10730
Leghorn	134600	12	7	0.530	0.3177	84600	12920
Guinea	159000	12	7	0.576	0.3453	100000	15200
Dotterel	176900	12	7	0.607	0.3642	111200	16440
Dorking	190800	12	7	0.631	0.3783	120000	17730
Cochin	211300	12	7	0.663	0.3981	132900	19640
Brahma	203200	16	9	0.714	0.4885	127800	27500

Reference Section — Cable Data

COMPACT ALUMINUM 1350 CABLE (ASTM B400) EXTRA HARD

Conductor Size		Class	No. of Wires	Cable Diameter (Inches)	Breaking Strength (pounds)
kcmil	AWG				
1000		B	61 ¹	1.060	17700
900		B	61 ¹	0.999	15900
800		B	61 ¹	0.938	14400
750		B	61 ¹	0.908	13500
700		B	61 ¹	0.877	12900
650		B	61 ¹	0.845	11900
600		B	61 ¹	0.813	11500
556		AA	19 ³	0.780	9750
550		B	61 ¹	0.775	10500
500		B	37 ²	0.736	9110
500		AA	19 ³	0.736	8760
477		AA	19 ³	0.722	8360
450		B	37 ²	0.700	8200
400		B	37 ²	0.659	7440
397		AA, A	19 ³	0.659	7110
350		B	37 ²	0.616	6760
350		A	19 ³	0.616	6390
336		A	19 ³	0.603	6150
336		AA	7	0.603	5960
300		B	37 ²	0.570	5890
300		A	19 ³	0.570	5480
300		AA	7	0.570	5430
266		A	19 ³	0.537	4970
266		AA	7	0.537	4830
250		B	37 ²	0.520	4910
250		A	19 ³	0.520	4660
250		AA	7	0.520	4520
	4/0	B	19 ³	0.475	4020
	4/0	AA, A	7	0.475	3830
	3/0	B	19 ³	0.423	3310
	3/0	AA, A	7	0.423	3040
	2/0	B	19 ³	0.376	2670
	2/0	AA, A	7	0.376	2510
	1/0	B	19 ³	0.336	2160
	1/0	AA, A	7	0.336	1990
	1	B	19 ³	0.299	1740
	1	AA, A	7	0.299	1640
	2	AA, A, B	7	0.268	1350
	3	A, B	7	0.238	1090
	4	A, B	7	0.213	.881
	6	A, B	7	0.169	.563
	8	A, B	7	0.134	.312

¹ 58 Wires Minimum

² 35 Wires Minimum

³ 18 Wires Minimum

Reference Section — Cable Data

ALUMINUM ALLOY 5005 CABLE (ASTM B397)

Conductor Size cmil	Number of Wires	Approx. Aluminum 1350 Size having Equivalent Resistance		Size & Stranding of ACSR with Equal Diameter			Rated Strength (pounds)
		cmil	AWG	cmil	AWG	Stranding	
927200	37	795000	-	795000	-	26/7	23900
740800	37	636000	-	636000	-	26/7	19300
652400	19	556500	-	556500	-	26/7	16200
587200	19	506500	-	506500	-	18/1	14600
559500	19	477000	-	477000	-	26/7	13900
503600	19	435500	-	435500	-	18/1	12500
465400	19	397500	-	397500	-	26/7	12200
419400	19	362000	-	362000	-	18/1	11200
394500	19	336400	-	336400	-	26/7	10500
355100	19	306400	-	306400	-	18/1	9600
312800	19	266800	-	266800	-	26/7	8450
281400	19	242900	-	242900	-	18/1	7610
246900	7	211600	4/0	211600	4/0	6/1	6330
195700	7	167800	3/0	167800	3/0	6/1	5020
155400	7	133100	2/0	133100	2/0	6/1	4280
123300	7	105600	1/0	105600	1/0	6/1	3440
77470	7	66360	2	66360	2	6/1	2200
48690	7	41740	4	41740	4	6/1	1430
30580	7	26240	6	26240	6	6/1	922

Reference Section — Cable Data

ALUMINUM ALLOY 6201 CABLE (ASTM B399)

Conductor Size cmil	Number of Wires	Approx. Aluminum 1350 Size having Equivalent Resistance		Size & Stranding of ACSR with Equal Diameter			Rated Strength (pounds)
		cmil	AWG	cmil	AWG	Stranding	
1439200	61	1272000	-	1272000	-	54/7	46800
1348800	61	1192500	-	1192500	-	54/7	43900
1259600	61	1113000	-	1113000	-	54/7	41000
1165100	61	1033500	-	1033500	-	54/7	37900
1077400	61	954000	-	954000	-	54/7	35000
927200	37	795000	-	795000	-	26/7	30500
740800	37	636000	-	636000	-	26/7	24400
652400	19	556500	-	556500	-	26/7	21900
559500	19	477000	-	477000	-	26/7	18800
465400	19	397500	-	397500	-	26/7	15600
394500	19	336400	-	336400	-	26/7	13300
312800	19	266800	-	266800	-	26/7	11000
246900	7	211600	4/0	211600	4/0	6/1	8560
195700	7	167800	3/0	167800	3/0	6/1	6790
155400	7	133100	2/0	133100	2/0	6/1	5390
123300	7	105600	1/0	105600	1/0	6/1	4460
77470	7	66360	2	66360	2	6/1	2800
48690	7	41740	4	41740	4	6/1	1760
30580	7	26240	6	26240	6	6/1	1110

Reference Section — Cable Data

ALUMINUM ALLOY 8000 SERIES “O” TEMPER CABLE (ASTM B801)

Conductor Size		Number of Wires†	Class	Conductor Diameter (inches)			Min. Breaking Strength (pounds)
kcmil	AWG			Conventional	Compressed	Compact	
1000		127	D	1.153	1.119	1.060	6010
1000		91	C	1.153	1.118	1.060	6010
1000		61	B, A	1.152	1.117	1.060	6010
900		127	D	1.095	1.062	0.999	5400
900		91	C	1.093	1.060	0.999	5400
900		61	B, A	1.093	1.060	0.999	5400
800		127	D	1.032	1.001	0.938	4800
800		91	C	1.032	1.001	0.938	4800
800		61	B, A	1.031	1.000	0.938	4800
750		127	D	0.998	0.968	0.908	4500
750		91	C	0.999	0.969	0.908	4500
750		61	B, A	0.998	0.938	0.908	4500
700		127	D	0.965	0.936	0.877	4200
700		91	C	0.965	0.936	0.877	4200
700		61	B, A	0.964	0.935	0.877	4200
650		127	D	0.930	0.902	0.845	3900
650		91	C	0.930	0.902	0.845	3900
650		61	B	0.929	0.901	0.845	3900
650		37	A	0.928	0.900	0.845	3950
600		127	D	0.893	0.866	0.813	3600
600		91	C	0.893	0.866	0.813	3600
600		61	B	0.893	0.866	0.813	3600
600		37	A	0.891	0.864	0.813	3640
556		127	D	0.861	0.835	0.780	3340
556		91	C	0.860	0.834	0.780	3340
556		61	B	0.860	0.834	0.780	3340
556		37	A	0.858	0.832	0.780	3380
550		127	D	0.855	0.829	0.775	3300
550		91	C	0.855	0.829	0.775	3300
550		61	B	0.855	0.829	0.775	3300
550		37	A	0.853	0.827	0.775	3340
500		91	D	0.815	0.791	0.736	3000
500		61	C	0.815	0.791	0.736	3000
500		37	B, A	0.813	0.789	0.736	3040
477		91	D	0.796	0.772	0.722	2860
477		61	C	0.796	0.772	0.722	2860
477		37	B, A	0.795	0.771	0.722	2900
450		91	D	0.773	0.750	0.700	2700
450		61	C	0.773	0.750	0.700	2700
450		37	B, A	0.772	0.749	0.700	2730

Reference Section — Cable Data

ALUMINUM ALLOY 8000 SERIES “O” TEMPER CABLE (ASTM B801) Continued

Conductor Size		Number of Wires†	Class	Conductor Diameter (inches)			Min. Breaking Strength (pounds)
kcmil	AWG			Conventional	Compressed	Compact	
400		91	D	0.729	0.707	0.659	2400
400		61	C	0.729	0.707	0.659	2400
400		37	B, A	0.728	0.706	0.659	2430
397		91	D	0.727	0.705	0.659	2390
397		61	C	0.726	0.704	0.659	2390
397		37	B	0.725	0.703	0.659	2410
397		19	A	0.724	0.702	0.659	2470
350		91	D	0.682	0.661	0.616	2100
350		61	C	0.681	0.661	0.616	2100
350		37	B	0.681	0.661	0.616	2130
350		19	A	0.679	0.659	0.616	2170
336		61	C	0.669	0.649	0.603	2020
336		37	B	0.668	0.648	0.603	2040
336		19	A	0.666	0.646	0.603	2090
300		61	C	0.631	0.612	0.570	1800
300		37	B	0.630	0.611	0.570	1820
300		19	A	0.629	0.610	0.576	1860
266		61	C	0.595	0.577	0.537	1600
266		37	B	0.594	0.576	0.537	1620
266		19	A	0.593	0.575	0.537	1660
250		61	C	0.576	0.559	0.520	1500
250		37	B	0.575	0.558	0.520	1520
250		19	A	0.574	0.557	0.520	1550
	4/0	37	C	0.529	0.513	0.475	1280
	4/0	19	B	0.528	0.512	0.475	1310
	4/0	7	A	0.522	0.506	0.475	1360
	3/0	37	C	0.471	0.457	0.423	1020
	3/0	19	B	0.470	0.456	0.423	1040
	3/0	7	A	0.464	0.450	0.423	1070
	2/0	19	B	0.419	0.406	0.376	826
	2/0	7	A	0.414	0.402	0.376	853
	1/0	19	B	0.373	0.362	0.336	655
	1/0	7	A	0.368	0.357	0.336	676
	1	19	B	0.332	0.322	0.229	519
	2	7	B, A	0.292	0.283	0.268	425
	3	7	B, A	0.260	0.252	0.238	337
	4	7	B, A	0.232	0.225	0.213	267
	6	7	B, A	0.184	0.178	0.169	168
	8	7	B, A	0.146	0.142	0.134	106

† For compact-stranded constructions, the number of wires may be reduced as follows:
 19-Wire Constructions - 18 Wires Minimum
 37-Wire Constructions - 35 Wires Minimum
 61-Wire Constructions - 58 Wires Minimum
 91-Wire Constructions - 87 Wires Minimum
 127-Wire Constructions - 122 Wires Minimum

Reference Section — Cable Data

COMPACT ACSR (ASTM B401)

Conductor Size		Cable Diameter (Inches)	Breaking Strength (pounds)
kcmil	AWG		
336.4		0.628	8260
266.8		0.559	6540
	4/0	0.517	7420
	3/0	0.461	5880
	2/0	0.410	4880
	1/0	0.365	3980
	1	0.326	3290
	2	0.298	3260
	2	0.290	2640
	3	0.258	2130
	4	0.236	2160
	4	0.229	1760
	6	0.182	1120

ACSR/TW (TRAP WIRE) CABLE (ASTM B779)

Conductor Size kcmil	Stranding		Nominal Diameter (inches)	Rated Strength (pounds)
	No. Aluminum Wires	No. Steel Wires		
336.4	14	1	0.63	8600
405.1	14	1	0.68	10200
477.0	18	7	0.78	17200
477.0	18	7	0.79	19400
556.5	18	7	0.84	20000
556.5	20	7	0.85	22600
565.3	20	7	0.86	22900
571.7	18	7	0.85	20600
636.0	27	1	0.85	13500
636.0	18	7	0.89	22900
636.0	20	7	0.91	25400
664.8	20	7	0.93	26600
666.6	20	7	0.91	24000
762.8	20	7	0.99	30500
768.2	20	7	0.98	27700
768.9	27	1	0.93	16400
795.0	17	7	0.96	21000
795.0	18	7	0.98	25900
795.0	20	7	0.99	28200
795.0	20	7	1.01	31800
946.7	35	7	1.08	29600
954.0	30	7	1.05	23700

Conductor Size kcmil	Stranding		Nominal Diameter (inches)	Rated Strength (pounds)
	No. Aluminum Wires	No. Steel Wires		
954.0	32	7	1.06	25900
954.0	20	7	1.08	33500
957.2	32	7	1.06	26000
959.6	22	7	1.11	37000
966.2	21	7	1.09	34000
1033.5	30	7	1.09	25700
1033.5	32	7	1.10	28100
1033.5	21	7	1.13	36300
1113.0	30	7	1.13	27500
1113.0	33	7	1.14	30000
1113.0	38	19	1.19	39100
1158.0	33	7	1.17	31600
1158.4	25	7	1.20	39600
1168.1	30	7	1.16	28900
1192.5	30	7	1.17	29500
1192.5	33	7	1.18	32400
1192.5	38	19	1.22	41900
1233.6	38	19	1.25	42900
1257.1	35	7	1.21	34200
1272.0	30	7	1.20	31400
1272.0	35	7	1.22	34600
1272.0	39	19	1.26	44100

Reference Section — Cable Data

ACSR/TW (TRAP WIRE) Continued

Conductor Size kcmil	Stranding		Nominal Diameter (inches)	Rated Strength (pounds)
	No. Aluminum Wires	No. Steel Wires		
1334.6	39	19	1.29	46300
1351.5	35	7	1.26	36700
1351.4	39	19	1.30	46800
1359.7	36	7	1.26	36900
1372.5	30	7	1.25	33400
1431.0	36	7	1.29	38900
1431.0	39	19	1.34	49600
1433.6	39	19	1.34	49700
1455.3	36	7	1.30	39200
1467.8	33	7	1.29	35800
1533.3	39	19	1.38	53200
1557.4	36	7	1.35	41900
1569.0	33	7	1.33	38200

Conductor Size kcmil	Stranding		Nominal Diameter (inches)	Rated Strength (pounds)
	No. Aluminum Wires	No. Steel Wires		
1590.0	36	7	1.36	42200
1590.0	42	19	1.41	55100
1622.0	39	19	1.42	57500
1657.4	36	7	1.39	44000
1730.6	39	19	1.47	59400
1758.6	37	19	1.47	34600
1780.0	37	19	1.45	50700
1926.9	42	19	1.55	65300
1949.6	42	7	1.50	51900
2153.8	64	19	1.60	61100
2156.0	64	19	1.61	61100
2627.3	64	19	1.76	74500

AAC/TW (ALL ALUMINUM TRAP WIRE) (ASTM B778)

Conductor Size kcmil	Nominal Diameter (inches)	Number of Wires	Rated Strength (pounds)
336.4	0.612	17	6220
397.5	0.661	17	7230
477.0	0.720	17	8530
500.0	0.736	17	8940
556.5	0.775	17	9950
600.0	0.803	17	10700
636.0	0.825	17	11400
700.0	0.864	17	12500
750.0	0.893	17	13400
795.0	0.919	17	13900
900.0	0.990	31	15800
954.0	1.018	31	16700
1000.0	1.041	31	17500
1033.5	1.057	31	18100
1113.0	1.095	31	19500
1192.5	1.132	31	20900
1272.0	1.168	31	22300
1351.5	1.202	31	23700
1431.0	1.236	31	24600
1590.0	1.315	49	27300
1750.0	1.377	49	30000
2000.0	1.468	49	34300

Reference Section — Cable Data

ACAR CABLE (ASTM B524)

Conductor Size		Number of Wires	Nominal Outside Diameter (inches)
kcmil	AWG		
2000		91	1.630
2000		61	1.630
1900		61	1.588
1800		61	1.546
1750		61	1.525
1700		61	1.502
1600		61	1.458
1500		61	1.411
1400		61	1.364
1300		61	1.314
1300		37	1.312
1250		61	1.288
1250		37	1.287
1200		61	1.263
1200		37	1.261
1100		61	1.209
1100		37	1.207
1000		61	1.152
1000		37	1.151
950		37	1.121
900		37	1.092
850		37	1.061
800		37	1.029
750		37	0.997
700		37	0.962
650		37	0.928
600		37	0.891
600		19	0.888
550		37	0.853
550		19	0.850
500		37	0.813
500		19	0.811
450		19	0.770
400		19	0.726
350		19	0.678
300		19	0.628
250		19	0.574
246.9		7	0.563

Conductor Size		Number of Wires	Nominal Outside Diameter (inches)
kcmil	AWG		
	4/0	7	0.522
195.7		7	0.502
	3/0	7	0.464
155.4		7	0.447
	2/0	7	0.414
123.3		7	0.398
	1/0	7	0.368
77.4		7	0.316
	2	7	0.292
48.6		7	0.250
	4	7	0.232
30.5		7	0.198

SSAC CABLE

Size AWG or kcmil	# Alum Strands	# Steel Strands	Conductor Diameter	Rated Strength (pounds)
266.8	22	7	.622	6030
266.8	24	7	.633	7410
266.8	26	7	.642	8880
266.8	30	7	.660	11700
300.0	26	7	.680	9970
336.4	20	7	.692	5990
336.4	22	7	.701	7610
336.4	24	7	.710	9340
336.4	26	7	.720	11200
336.4	30	7	.741	14800
397.5	20	7	.752	7090
397.5	22	7	.762	8990
397.5	24	7	.772	11000
397.5	26	7	.783	13000
397.5	30	7	.806	17500
477.0	20	7	.823	8490
477.0	22	7	.834	10800
477.0	24	7	.846	13000
477.0	26	7	.858	15600
477.0	30	7	.883	21000
500.0	30	7	.904	22000

Reference Section — Cable Data

SSAC CABLE (Continued)

Size AWG or kcmil	# Alum Strands	# Steel Strands	Conductor Diameter	Rated Strength (pounds)
556.5	20	7	.890	9910
556.5	22	7	.901	12600
556.5	24	7	.914	15200
556.5	26	7	.927	18200
556.5	30	7	.953	24500
605.0	24	7	.953	16500
605.0	26	7	.966	19700
605.0	30	7	.994	26000
605.0	30	19	.994	26600
636.0	20	7	.951	11300
636.0	22	7	.963	14100
636.0	24	7	.977	17300
636.0	26	7	.990	20700
636.0	30	7	1.019	27400
636.0	30	19	1.019	28000
666.6	24	7	1.000	18200
666.6	26	7	1.104	21700
715.5	24	7	1.036	19500
715.5	26	7	1.051	23300
715.5	30	19	1.081	30800
795.0	42	7	1.055	11800
795.0	20	7	1.063	14200
795.0	45	7	1.063	14200
795.0	22	7	1.077	17700
795.0	24	7	1.092	21700
795.0	54	7	1.092	21700
795.0	26	7	1.108	25900
795.0	30	19	1.140	34300
900.0	45	7	1.131	15800
900.0	54	7	1.162	24600
954.0	42	7	1.155	14200
954.0	20	7	1.185	16700
954.0	45	7	1.165	16700
954.0	48	7	1.175	19700
954.0	24	7	1.196	26000
954.0	54	7	1.196	26000
954.0	30	19	1.248	41100
1033.5	42	7	1.203	15400

Size AWG or kcmil	# Alum Strands	# Steel Strands	Conductor Diameter	Rated Strength (pounds)
1033.5	45	7	1.212	18100
1033.5	48	7	1.222	21300
1033.5	54	7	1.245	28200
1113.0	42	7	1.248	16300
1113.0	45	7	1.259	19500
1113.0	48	7	1.269	23000
1113.0	54	19	1.293	30400
1192.5	42	7	1.292	17500
1192.5	45	7	1.302	20900
1192.5	48	7	1.313	24600
1192.5	54	19	1.338	32600
1272.0	42	7	1.334	18700
1272.0	45	7	1.345	22300
1272.0	48	7	1.357	26200
1272.0	54	19	1.382	34100
1351.5	42	7	1.376	19900
1351.5	45	7	1.386	23700
1351.5	48	7	1.398	27900
1351.5	54	19	1.424	36200
1431.0	42	7	1.415	21000
1431.0	45	7	1.427	25100
1431.0	48	7	1.439	29500
1431.0	54	19	1.465	38400
1510.5	45	7	1.466	26500
1510.5	54	19	1.505	40500
1590.0	42	7	1.492	23400
1590.0	45	7	1.504	27900
1590.0	48	7	1.517	32200
1590.0	54	19	1.545	42600
1780.0	84	19	1.602	35400
1869.0	68	7	1.603	21500
2034.5	72	7	1.681	27200

Reference Section — Cable Data

SOLID COPPERWELD CABLE (ASTM B227)

Conductor Size (AWG)	Nominal Diameter (inches)	Circular Mils	Minimum Breaking Load (pounds)			
			Grade 40 HS	Grade 40 EHS	Grade 30 HS	Grade 30 EHS
4	0.2043	41740	3540	-	3934	4671
5	0.1819	33090	2937	-	3249	3911
-	0.1650*	27230	2779	-	2779	3367
6	0.1620	26240	2679	-	2679	3246
7	0.1443	20820	2207	-	2207	2681
8	0.1285	16510	1816	-	1816	2205
-	0.1280*	16380	1802	-	1802	2188
9	0.1144	13090	1491	-	1491	1790
-	0.1040*	10820	1283	1325	1283	1487
10	0.1019	10380	1231	-	1231	1460
12	0.0808	6530	774	-	774	918
-	0.0800*	6400	759	-	759	900
-	0.0640*	4096	485	-	485	576
18	0.0403	1624	193	-	193	228
-	0.0390*	1521	180	-	180	214
20	0.0320	1024	121	-	121	144

* These diameters are often employed by purchasers for communication lines BUT are not in the American Wire Gauge (B&S Wire Gauge) series, as are the other diameter listed.

STRANDED COPPERWELD CABLE (ASTM B228)

Nominal Diameter† (inch) Size AWG‡	Circular Mils	Diameter* (inch)	Breaking Load (pounds)**		
			High Strength		Extra High Strength
			40% Cond.	30% Cond.	30% Cond.
7/8 (19 No. 5)	628900	.910	50240	55570	66910
13/16 (19 No. 6)	498800	.810	41600	45830	55530
23/32 (19 No. 7)	395500	.721	34390	37740	45850
27/32 (19 No. 8)	313700	.642	28380	31040	37690
9/16 (19 No. 9)	248800	.572	23390	25500	30610
5/8 (7 No. 4)	292200	.613	22310	24780	29430
9/16 (7 No. 5)	231700	.546	18510	20470	24650
1/2 (7 No. 6)	183800	.486	15330	16890	20460
7/16 (7 No. 7)	145700	.433	12670	13910	16890
3/8 (7 No. 8)	115600	.385	10460	11440	13890
11/32 (7 No. 9)	91650	.343	8616	9393	11280
5/16 (7 No. 10)	72680	.306	7121	7758	9196
3 No. 5	99310	.392	8373	9262	11860
3 No. 6	78750	.349	6934	7639	9754
3 No. 7	62450	.311	5732	6291	7922
3 No. 8	49530	.277	4730	5174	6282
3 No. 9	39280	.247	3898	4250	5129
3 No. 10	31150	.220	3221	3509	4160
3 No. 12	19590	.174	2236	-	-

† The designation "inch" is the approximate diameter in proper fraction of an inch.

‡ The designation AWG is a combination of the number of wires each of the American Wire Gauge size indicated by "No."

* Diameter of circumscribing.

** Breaking loads of 7-wire and 19-wire conductors are taken as 90% of the sum of the breaking loads of individual wires; breaking load of 3-wire conductors is taken as 95% of the sum of the breaking loads of the individual wires.

Reference Section — Cable Data

COPPERWELD-COPPER CABLE (ASTM B229)

Conductor size Hard Drawn Copper Equivalent			Nom. Dia. of Conductor (inches)	Min. Breaking Load (pounds)
cmil	AWG	Type		
350000	-	E	0.788	32420
350000	-	EK	0.735	23850
350000	-	V	0.754	23480
300000	-	E	0.729	27770
300000	-	EK	0.680	20960
300000	211600	V	0.698	20730
250000	-	E	0.666	23920
250000	-	EK	0.621	17840
250000	-	V	0.637	17420
	4/0	E	0.613	20730
211600	4/0	G	0.583	15640
211600	4/0	EK	0.571	15370
211600	4/0	V	0.586	15000
211600	4/0	F	0.550	12290
167800	3/0	E	0.545	16800
167800	3/0	J	0.555	16170
167800	3/0	G	0.519	12860
167800	3/0	EK	0.509	12370
167800	3/0	V	0.522	12200
167800	3/0	F	0.490	9980
133100	2/0	K	0.534	17600
133100	2/0	J	0.494	13430
133100	2/0	G	0.463	10510
133100	2/0	V	0.465	9846
133100	2/0	F	0.436	8094
105600	1/0	K	0.475	14490
105600	1/0	J	0.440	10970
105600	1/0	G	0.412	8563
105600	1/0	F	0.388	6536
83690	1	N	0.464	15410
83690	1	K	0.423	11900
83690	1	J	0.392	9000
83690	1	G	0.367	6956
83690	1	F	0.346	5266
66360	2	P	0.462	16870
66360	2	N	0.413	12680
66360	2	K	0.377	9730
66360	2	J	0.349	7322
66360	2	A	0.366	5876
66360	2	G	0.327	5626
66360	2	F	0.308	4233
55620	3	P	0.411	13910
52620	3	N	0.368	10390

Conductor size Hard Drawn Copper Equivalent			Nom. Dia. of Conductor (inches)	Min. Breaking Load (pounds)
cmil	AWG	Type		
52620	3	K	0.336	7910
52620	3	J	0.311	5955
52620	3	A	0.326	4810
41740	4	P	0.366	11420
41740	4	N	0.328	8460
41740	4	D	0.348	7340
41740	4	A	0.290	3938
33090	5	P	0.326	9311
33090	5	D	0.310	6035
33090	5	A	0.258	3193
26240	6	D	0.276	4942
26240	6	A	0.230	2585
26240	6	C	0.225	2143
20820	7	D	0.246	4022
20820	7	A	0.223	2754
16510	8	D	0.219	3256
16510	8	A	0.199	2233
16510	8	C	0.179	1362
11750	9	D	0.174	1743

Reference Section — Cable Data

GALVANIZED STEEL CABLE (ASTM A475)

inches	Nom. Dia. of Strand (mm)	Number of Wires in Strand	Minimum Breaking Load (pounds)				
			Utilities Grade	Common Grade	Siemens-Martin Grade	High-Strength Grade	Extra High-Strength Grade
1/8	3.18	7	-	540	910	1330	1830
5/32	3.97	7	-	870	1470	2140	2940
3/16	4.76	7	-	1150	1900	2850	3990
3/16	4.76	7	2400	-	-	-	-
7/32	5.56	3	-	1400	2340	3500	4900
7/32	5.56	7	-	1540	2560	3850	5400
1/4	6.35	3	3150	1860	3040	4730	6740
1/4	6.35	3	4500	-	-	-	-
1/4	6.35	7	-	1900	3150	4750	6650
9/32	7.14	3	-	2080	3380	5260	7500
9/32	7.14	7	4600	2570	4250	6400	8950
5/16	7.94	3	6500	2490	4090	6350	9100
5/16	7.94	7	-	3200	5350	8000	11200
5/16	7.94	7	6000	-	-	-	-
3/8	9.52	3	8500	3330	5560	8360	11800
3/8	9.52	7	11500	4250	6950	10800	15400
7/16	11.11	7	18000	5700	9350	14500	20800
1/2	12.70	7	25000	7400	12100	18800	26900
1/2	12.70	19	-	7620	12700	19100	26700
9/16	14.29	7	-	9600	15700	24500	35000
9/16	14.29	19	-	9640	16100	24100	33700
5/8	15.88	7	-	11600	19100	29600	42400
5/8	15.88	19	-	11000	18100	28100	40200
3/4	19.05	19	-	16000	26200	40800	58300
7/8	22.22	19	-	21900	35900	55800	79700
1	25.40	9	-	28700	47000	73200	104500
1	25.40	37	-	28300	46200	71900	102700
1-1/8	28.58	37	-	36000	58900	91600	130800
1-1/4	31.75	37	-	44600	73000	113600	162200

Reference Section — Cable Data

ALUMINUM-COATED STEEL CABLE (ASTM A474)

Nom. Dia. of Strand (inches)	Number of Wires in Strand	Minimum Breaking Strength (pounds)				
		Utilities Grade*	Common Grade	Siemens-Martin Grade	High-Strength Grade	Extra High-Strength Grade
3/16	7		1150	1900	2850	
3/16	7	2400				
1/4	3	3150				
1/4	3	4500				
1/4	7		1900	3150	4750	6650
9/32	7	4600				
5/16	3	6500				
5/16	7		3200	5350	8000	11200
5/16	7	6000				
3/8	3	8500				
3/8	7	11500	4250	6950	10800	15400
7/16	7	18000	5350	9350	14500	20800
1/2	7	25000	7400	12100	18800	26900

* The Utilities Grade is used principally by communications and power and light industries.

Reference Section — AWG vs. METRIC WIRE SIZES

Circ. Mils	Equivalent Circ. Mils	AWG Size	Metric Wire Size (mm)	Number of Strands	Wire Dia. per Strand		Approx. Overall Diameter	
					inches	mm	inches	mm
-	937	-	.50	1	.032	.813	.032	.81
1020	-	20	-	7	.0121	.307	.036	.91
-	1480	-	.75	1	.039	.091	.039	.99
1620	-	18	-	1	.0103	1.02	.040	1.02
1620	-	18	-	7	.0152	.386	.046	1.16
-	1974	-	1.0	1	.045	1.14	.045	1.14
-	1974	-	1.0	7	.017	.422	.061	1.30
2580	-	16	-	1	.0503	1.29	.051	1.29
2580	-	16	-	7	.0192	.468	.058	1.46
-	2960	-	1.5	1	.055	1.40	.055	1.40
-	2960	-	1.5	7	.021	5.33	.063	1.60
4110	-	14	-	1	.0641	1.63	.064	1.63
4110	-	14	-	7	.0242	.615	.073	1.84
-	4934	-	2.5	1	.071	1.80	.071	1.80
-	4934	-	2.5	7	.027	6.66	.081	2.06
6530	-	12	-	1	.0308	2.05	.081	2.05
6530	-	12	-	7	.0305	.775	.092	2.32
-	7894	-	4	1	.089	2.26	.089	2.26
-	7894	-	4	7	.034	.864	.102	2.59
10380	-	10	-	1	.1019	2.59	.102	2.59
10380	-	10	-	7	.0355	.978	.116	2.93
-	11840	-	6	1	.109	2.77	.109	2.77
-	11840	-	6	7	.042	.107	.126	3.21
13000	-	9	-	1	.1144	2.91	.114	2.91
13090	-	9	-	7	.0432	1.10	.130	3.30
16510	-	8	-	1	.1285	3.26	.128	3.25
16510	-	8	-	7	.0486	1.23	.146	3.70
-	19740	-	10	1	.141	3.58	.141	3.58
-	19740	-	10	7	.054	1.37	.162	4.12
20520	-	7	-	1	.1443	3.67	.144	3.67
20520	-	7	-	7	.0545	1.38	.164	4.15
26240	-	6	-	1	.162	4.11	.162	4.11
26240	-	6	-	7	.0612	1.55	.184	4.66
-	31580	-	16	7	.008	1.73	.204	5.13
33090	-	5	-	7	.0688	1.75	.206	5.24
41740	-	4	-	7	.0772	1.96	.232	5.88
-	49340	-	25	7	.085	2.16	.255	6.48
-	49340	-	25	19	.052	1.32	.260	6.60
52620	-	3	-	7	.0867	2.20	.260	6.61
66300	-	2	-	7	.0974	2.47	.292	7.42
-	69070	-	35	7	.100	2.54	.300	7.62
-	69070	-	35	19	.001	1.55	.305	7.75

Reference Section — Cable Data

Circ. Mils	Equivalent Circ. Mils	AWG Size	Metric Wire Size (mm)	Number of Strands	Wire Dia. per Strand		Approx. Overall Diameter	
					inches	mm	inches	mm
83690	-	1	-	19	.0064	1.50	.332	8.43
-	98680	-	50	19	.073	1.85	.365	9.27
105000	-	1/0	-	19	.0745	1.59	.373	9.46
133100	-	2/0	-	19	.0837	2.13	.419	10.6
-	138100	-	70	19	.086	2.18	.430	10.9
167800	-	3/0	-	19	.094	2.59	.470	11.9
167800	-	3/0	-	36	.0673	1.71	.471	12.0
-	187500	-	95	19	.101	2.57	.505	12.8
-	187500	-	95	37	.072	1.83	.504	12.5
211600	-	4/0	-	19	.1055	2.89	.528	13.4
-	237.8 kcmil	-	120	37	.081	2.06	.567	14.4
250 kcmil	-	-	-	37	.0822	2.07	.575	14.6
300 kcmil	-	-	150	37	.090	2.29	.630	16.0
350 kcmil	-	-	-	37	.0973	2.47	.681	17.3
-	365.1 kcmil	-	185	37	.100	2.54	.700	17.8
400 kcmil	-	-	-	37	.104	2.64	.728	18.5
-	473.6 kcmil	-	240	37	.114	2.90	.798	20.3
-	473.6 kcmil	-	240	61	.089	2.26	.801	20.3
500 kcmil	-	-	-	37	.1162	2.95	.813	20.7
500 kcmil	-	-	-	61	.0905	2.30	.814	20.7
-	592.1 kcmil	-	300	61	.099	2.51	.891	22.6
600 kcmil	-	-	-	61	.0992	2.52	.893	22.7
700 kcmil	-	-	-	61	.1071	2.72	.964	24.5
750 kcmil	-	-	-	6	.1109	2.82	.998	25.4
750 kcmil	-	-	-	91	.0908	2.31	.998	25.4
-	789.4 kcmil	-	400	61	.114	2.90	1.026	26.1
800 kcmil	-	-	-	61	.1145	2.91	1.031	26.2
800 kcmil	-	-	-	91	.0938	2.38	1.032	26.2
1000 kcmil	986.8 kcmil	-	500	61	.1280	3.25	1.152	28.3
1000 kcmil	-	-	-	91	.1048	2.66	1.153	29.3
-	1233.7 kcmil	-	625	91	.117	2.97	1.287	32.7
1250 kcmil	-	-	-	91	.1172	2.93	1.289	32.7
1250 kcmil	-	-	-	127	.0992	2.52	1.200	32.8
1500 kcmil	-	-	-	91	.1284	3.26	1.412	36.9
1500 kcmil	-	-	-	127	.1087	2.76	1.413	36.9
-	1578.8 kcmil	-	800	91	.132	3.35	1.452	36.9
-	1973.5 kcmil	-	1000	91	.147	3.73	1.617	41.1
2000 kcmil	-	-	-	127	.1255	3.19	1.632	41.5
2000 kcmil	-	-	-	169	.1088	2.76	1.632	41.5

Alpha-Numeric Index

Catalog Number	Page
AT16A15A30	A-109
AT17A15A30	A-109
AT181530	C-81
AT181630	C-81
AT18A16A20	A-109
AT18A16A30	A-109
AT191730	C-81
AT191830	C-81
AT19A17A30	A-109
AT19A18A20	A-109
AT19A18A30	A-109
AT19A19A30	A-109
AT20A17A20	A-109
AT20A17A30	A-109
AT20A18A20	A-109
AT20A18A30	A-109
AT21A17A30	A-109
AT21A18A20	A-109
AT21A18A30	A-109
AT21A19A30	A-109
AT22A17A30	A-109
AT22A18A20	A-109
AT22A18A30	A-109
AT22A19A20	A-109
AT22A19A30	A-109
AT22A20A30	A-109
AT24A19A20	A-109
AT24A19A30	A-109
AT24A20A20GS	A-109
AT86A20A30	A-109
CB15	C-123
CB15A	A-163, A-258
CB16	C-123
CB16A	A-163, A-258
CB17	C-123
CB17A	A-163, A-258
CB18	C-123
CB18A	A-163, A-258
CB19	C-123
CB19A	A-163, A-258
CB20	C-123
CB20A	A-163, A-258

Catalog Number	Page
CB21A	A-163, A-258
CB22	C-123
CB22A	A-163, A-258
CB24A	A-163, A-258
CB86A	A-163, A-258
CP3R445A4	A-148
CP4444L4	A-135
CP44AL4	A-135
CP44AL6	A-135
CP45AL4	A-135
CP45AL6	A-135
CP48AL4	A-135
CP48AL6	A-135
CPR34A4	A-136
CPR42A4	A-136
CPR46A4	A-136
E2C34G1	C-118
E3C34G1	C-118
E4C34G1	C-118
FB11G3LD	C-111
FB13G20	C-111
FB13G21W	C-111
FB13G22	C-111
FB13G23	C-111
FB14ACG1	C-111
FCB63-2NP300	C-112
FCB63-4N	C-112
FCB63-6N	C-112
FCB642NP300	C-112
FCB64-44NP50	C-112
FCB644G4	C-112
FCB64-4N	C-112
FCB64-6N	C-112
FCB65-4N	C-112
FD635B6T11	C-85
FD635C5T0	C-85
FD635C6T11	C-85
FD63C6T13	C-85
FD645C5	C-85
FD645C5T14	C-85
FD645D16T0	C-86
FD645D8T0	C-86

Catalog Number	Page
FD64B5	C-85
FD64B5T0	C-85
FD64B5T16	C-85
FD64B6	C-85
FD64B6T16	C-85
FD64C5	C-85
FD64C5T10	C-85
FD64C5T16	C-85
FD64CT16	C-85
FD64D5	C-85
FD64D5T0	C-85
FD655AC6	A-115
FD655AD6	A-115
FD655B6	C-86
FD655C6	C-86
FD655C6T0	C-86
FD655C6T16	C-86
FD655D12	C-86
FD655D6	C-86
FD65B6	C-86
FD65C6	C-86
FD65C6T0	C-86
FD65C6T14	C-86
FD65D12T0	C-86
FD65D6T14	C-86
FD66B8	C-86
FD66C6	C-86
FD66D6	C-86
FD66D8	C-86
FD675C8	C-86
FD675D12	C-86
FD675D8	C-86
FD67AC6	A-115
FD67AD8	A-115
FD685C8	C-86
FD685D12	C-86
FD685D16	C-86
FD685D8	C-86
FD68AD12	A-115
FD68AD8	A-115
FD68C8	C-86
FD68D12	C-86

Alpha-Numeric Index

Catalog Number	Page
FD68D16	C-86
FD68D8	C-86
FD69C8	C-87
FD69D12	C-87
FD69D16	C-87
FD69D8	C-87
FD702D12T0	C-87
FD702D16T0	C-87
FD70AD12	A-115
FD70C8	C-87
FD70D12	C-87
FD70D16	C-87
FD70D16HQ	C-87
FD70D8	C-87
FD71D12	C-87
FD72D12	C-87
FD72D16CG1	C-87
FD72D22	C-87
FD72D27CG1	C-87
FDA655B6	C-90
FDA655C6	C-90
FDA655D6	C-90
FDA66C6	C-90
FDA67C6	C-90
FDA67D8	C-90
FDA68D12	C-90
FDA68D8	C-90
FDA70D12	C-90
FDR64B6T10	C-89
FDR64C6T16	C-89
FDR655B6	C-89
FDR655C6	C-89
FDR655D6	C-89
FDR65C6T14	C-89
FDR66B6	C-89
FDR66C6	C-89
FDR66D6	C-89
FDR675C6	C-89
FDR675D8	C-89
FDR67B6	C-89
FDR67C6	C-89
FDR67D8	C-89

Catalog Number	Page
FDR68D8	C-89
FDR69D8	C-89
FDR70D12	C-89
HFB22	C-113
HFB22P1	C-114
HFB33	C-113
HFB33-4N	C-119
HFB33CG3	C-113
HFB33P1	C-114
HFB42	C-113
HFB42P1	C-114
HFB43CG1	C-113
HFB44	C-113
HFB44-4N	C-119
HFB44CG11	C-113
HFB44G30W	C-115
HFB44G31W	C-115
HFB44G32W	C-115
HFB44P1	C-114
HFB44T16	C-113
HFB52P1	C-114
HFB53P1	C-114
HFB54P1	C-114
HFB55P1	C-114
HFB62P1	C-114
HFB63P1	C-114
HFB64P1	C-114
HFB66-6N	C-119
HHHB143	C-116
HHHB423	C-116
HHHB853	C-116
HP44	C-117
HP53	C-117
HP66	C-117
L2H453	C-51
L2H455	C-51
LB13A	A-161, A-255
LB14	C-124
LB14A	A-161, A-255
LB15	C-124
LB15A	A-161, A-255
LB16	C-124

Catalog Number	Page
LB16A	A-161, A-255
LB17	C-124
LB17A	A-161, A-255
LB18	C-124
LB18A	A-161, A-255
LB19	C-124
LB19A	A-161, A-255
LB20	C-124
LB20A	A-161, A-255
LB21A	A-161, A-255
LB22	C-124
LB22A	A-161, A-255
LB23A	A-161, A-255
LB24A	A-161, A-255
LB53A	A-161, A-255
LB54A	A-161, A-255
LB55	C-124
LB55A	A-161, A-255
LB56A	A-161, A-255
LB57	C-124
LB57A	A-161, A-256
LB58	C-124
LB58A	A-161, A-256
LB59	C-124
LB59A	A-161, A-256
LB83A	A-161, A-255
LB86A	A-161, A-255
LB88A	A-161, A-255
LB90A	A-162, A-256
LB91A	A-162, A-256
LB92	C-124
LB92A	A-162, A-256
LB94A	A-162, A-256
LB96A	A-162, A-256
LH283	C-47
LH343	C-47
LH453	C-47
LHL48L50	C-49
LHR293	C-48
LHR443	C-48
LHR445	C-48
N11DR6434T16	C-95

Alpha-Numeric Index

Catalog Number	Page
N11DR6534T14	C-95
N11DR6544T12	C-95
N11DR6734T12	C-95
N11DR6744T0	C-95
N11DR6744T12	C-95
N11DR67544T12	C-95
N11DR6844T12	C-95
N11DR6848T12	C-95
N11DR7048T12	C-95
N2AH292N	C-7
N2AH292N45	C-8
N2AH2934N	C-7
N2AH342N	C-7
N2AH342N90	C-8
N2AH3434N	C-7
N2AH3434N90	C-8
N2AH3444N	C-7
N2AH3444N90	C-8
N2AH402N90	C-8
N2AH4034N	C-7
N2AH4034N90	C-8
N2AH4434N	C-7
N2AH4434N45	C-8
N2AH4434N90	C-8
N2AH4444N	C-7
N2AH4444N45	C-8
N2AH4444N90	C-8
N2AH4444NHQ	C-7
N2AH4644N	C-7
N2AH4844N	C-7
N2AH4844N90	C-8
N2BCR36A44N	A-94
N2BCR42A34N	A-94
N2BCR42A44N	A-94
N2BCR45A44N	A-94
N2BCR48A2N	A-94
N2BCR48A44N	A-94
N2D6731T12	C-103
N2D6734T12	C-103
N2D67534T12	C-103
N2D67539T12	C-103
N2D6834T12	C-103

Catalog Number	Page
N2DR6644T12	C-94
N2DR6744T12	C-94
N2DR6748AT12	A-120
N2DR6848AR12	A-121
N2T1534	C-63
N2T1634	C-63
N2T1644	C-63
N2T1734	C-63
N2T1934	C-63
N2T1944	C-63
N2T2039	C-63
N2T2044	C-63
N2T3434CG1	C-63
N2T4434	C-63
N3DR65544T12	C-98
N3DR6844T12	C-98
N3DR7044T12	C-98
NA122N	C-9
NA132N	C-9
NA132N90	C-10
NA13A2N	A-11
NA142N	C-9
NA142N90	C-10
NA144N	C-9
NA144N90	C-10
NA14A2N	A-11
NA14A4N	A-11
NA152N	C-9
NA152N90	C-10
NA154N	C-9
NA154N90	C-10
NA15A2N	A-11
NA15A34N90	A-13
NA15A44N	A-11
NA15A44N90	A-13
NA15A4N	A-11
NA162N	C-9
NA162N90	C-10
NA164N	C-9
NA164N90	C-10
NA16A2N	A-11
NA16A2N90	A-13

Catalog Number	Page
NA16A4N	A-11
NA172N	C-9
NA172N90	C-10
NA1744N90HQ	C-10
NA1744NHQ	C-9
NA174N	C-9
NA174N90	C-10
NA17A2N	A-11
NA17A34N	A-11
NA17A4N	A-11
NA182N	C-9
NA182N90	C-10
NA184N	C-9
NA184N90	C-10
NA184N90HC	C-10
NA18A2N	A-11
NA18A2N90	A-13
NA18A34N	A-11
NA18A44N	A-11
NA18A4N	A-11
NA18A4N45	A-13
NA18A4N90	A-13
NA1944N	C-9
NA1944N90HQ	C-10
NA1944NHQ	C-9
NA194N	C-9
NA194N90	C-10
NA194N90CG2	C-9, C-10
NA19A2N	A-11
NA19A2N90	A-13
NA19A34N	A-11
NA19A44N	A-11
NA19A44N90	A-13
NA19A4N	A-11
NA19A4N90	A-13
NA204N	C-9
NA20A2N	A-12
NA20A34N	A-12
NA20A44N	A-12
NA20A4N	A-12
NA20A4N90	A-13
NA214N	C-9

Alpha-Numeric Index

Catalog Number	Page
NA214N90	C-10
NA21A34N	A-12
NA21A4N	A-12
NA21A4N90	A-13
NA2244N90	C-10
NA224N	C-9
NA22A34N	A-12
NA22A34N90	A-13
NA22A44N	A-12
NA22A4N	A-12
NA22A4N90GS	A-13
NAC15A2N	A-14
NAC15A34N	A-14
NAC15A4N	A-14
NAC1734N	C-11
NAC1744N	C-11
NAC17A2N	A-14
NAC17A34N	A-14
NAC17A44N	A-14
NAC1834N	C-11
NAC1844N	C-11
NAC18A2N	A-14
NAC18A34N	A-14
NAC18A44N	A-14
NAC18A4N	A-14
NAC1934N	A-14
NAC194N	A-14
NAC19A34N	A-14
NAC19A44N	A-14
NAC204N	A-14
NAC20A34N	A-14
NAC20A44N	A-14
NAC21A34N	A-14
NAC21A44N	A-14
NAC22A34N	A-15
NAC22A44N	A-15
NAC22A4N	A-15
NAC22A66N	A-15
NAC24A44N	A-15
NAC24A4N	A-15
NAC86A44N	A-15
NAH292N	C-5

Catalog Number	Page
NAH292N45	C-6
NAH292N90	C-6
NAH2934N	C-5
NAH342N	C-5
NAH342N45	C-6
NAH342N90	C-6
NAH3434N	C-5
NAH3434N90	C-6
NAH402N	C-5
NAH402N90	C-6
NAH4034N	C-5
NAH4034N45	C-6
NAH4034N90	C-6
NAH4044N	C-5
NAH442N	C-5
NAH442N45	C-6
NAH442N90	C-6
NAH4434N	C-5
NAH4434N45	C-6
NAH4434N90	C-6
NAH4444N	C-5
NAH462N	C-5
NAH4634N	C-5
NAH4644N	C-5
NAH482N	C-5
NAH4834N	C-5
NAH4844N	C-5
NAH4844N90	C-6
NAH4862N	C-5
NAH48634N	C-5
NAR25A2N	A-3
NAR25A2N90	A-5
NAR26A2N	A-3
NAR29A2N	A-3
NAR29A2N90	A-5
NAR29A4N	A-3
NAR29A4N90	A-5
NAR32A2N	A-3
NAR32A2N45	A-5
NAR32A2N90	A-5
NAR32A44N	A-3
NAR32A4N	A-3

Catalog Number	Page
NAR32A4N45	A-5
NAR32A4N90	A-5
NAR32ACG2	A-3
NAR36A2N	A-3
NAR36A2N45	A-5
NAR36A2N90	A-5
NAR36A44N	A-3
NAR36A44N90	A-5
NAR36A4N	A-3
NAR36A4N45	A-5
NAR36A4N90	A-5
NAR42A2N	A-3
NAR42A2N45	A-6
NAR42A2N90	A-6
NAR42A44N	A-3
NAR42A44N90GS	A-6
NAR42A4N	A-3
NAR42A4N45	A-6
NAR42A4N90	A-6
NAR45A2N	A-4
NAR45A44N	A-4
NAR45A44N90	A-6
NAR45A4N	A-4
NAR45A4N135	A-6
NAR45A4N45	A-6
NAR45A4N90	A-6
NAR46A2N	A-4
NAR46A2N90	A-6
NAR46A44N	A-4
NAR46A44N45	A-6
NAR46A44N90	A-6
NAR46A4N	A-4
NAR46A4N45	A-6
NAR46A4N90	A-6
NAR486A44N	A-4
NAR486A44N90	A-6
NAR48A2N	A-4
NAR48A44N	A-4
NAR48A44N90	A-6
NAR48A4N	A-4
NAR48A4N45	A-6
NAR48A4N90	A-6

Alpha-Numeric Index

Catalog Number	Page
NAR495A46N	A-4
NAR495A46N45	A-6
NAR495A46N90	A-6
NAR495A66N	A-4
NAR495A66N45	A-6
NAR495A66N90	A-6
NAS292N	C-3
NAS292N90	C-4
NAS2934N	C-3
NAS2934N90	C-4
NAS29N	C-3
NAS29N90	C-4
NAS342N	C-3
NAS342N90	C-4
NAS3434N	C-3
NAS3434N90	C-4
NAS34N	C-3
NAS402N	C-3
NAS4034N	C-3
NAS4034N45	C-4
NAS4044N	C-3
NB144N	C-64
NB152N	C-64
NB164NCG1	C-64
NB342N	C-64
NB344N	C-64
NBC142N	C-65
NBC144N	C-65
NBC14A2N	A-90
NBC152N	C-65
NBC1534N	C-65
NBC15A-2N	A-90
NBC15A34N	A-90
NBC162N	C-65
NBC16A2N	A-90
NBC16A34N	A-90
NBC16A44N	A-90
NBC172N	C-65
NBC1734N	C-65
NBC1744N	C-65
NBC17A2N	A-90
NBC17A34N	A-90

Catalog Number	Page
NBC17A44N	A-90
NBC182N	C-65
NBC1834N	C-65
NBC1844NHQ	C-65
NBC184N	C-65
NBC18A2N	A-90
NBC18A34N	A-90
NBC18A-44N	A-90
NBC19A34N	A-90
NBC19A44N	A-90
NBC204N	C-65
NBC20A2N	A-91
NBC20A34N	A-91
NBC20A-44N	A-91
NBC21A44N	A-91
NBC224N	C-65
NBC22A2N	A-91
NBC22A34N	A-91
NBC22A44N	A-91
NBC24A2N	A-91
NBC24A34N	A-91
NBC24A44N	A-91
NBC86A44N	A-91
NBCR29A2N	A-92
NBCR29A34N	A-92
NBCR32A2N	A-92
NBCR32A34N	A-92
NBCR32A44N	A-92
NBCR36A2N	A-92
NBCR36A34N	A-92
NBCR36A44N	A-92
NBCR42A2N	A-92
NBCR42A34N	A-92
NBCR42A44N	A-92
NBCR45A2N	A-92
NBCR45A32N	A-92
NBCR45A34N	A-92
NBCR45A44N	A-92
NBCR46A34N	A-93
NBCR46A44N	A-93
NBCR486A44N	A-93
NBCR48A2N	A-93

Catalog Number	Page
NBCR48A34N	A-93
NBCR48A44N	A-93
NBCR495A44N	A-93
NBXR1534NHQ	C-19
NBXR1544NHQ	C-19
NBXR15CG1	C-19
ND6327R13	C-101
ND6414T16	C-102
ND6428T16	C-102
ND6513T12	C-102
ND6516AT14	A-116
ND65515T12	C-102
ND65516T12	C-102
ND65517R12	C-101
ND65518AT12	A-116
ND65526R12	C-101
ND6615T12	C-102
ND6618AT12	A-116
ND6634R14	C-101
ND6639T14	C-102
ND6644R14	C-101
ND6714T12	C-102
ND6715AT12	A-116
ND6715T12	C-102
ND6716AT12	A-116
ND6716T12	C-102
ND6717AT12	A-116
ND6718AT12	A-116
ND6718R12	C-101
ND6719AT12GS	A-116
ND6728R12	C-101
ND6734R12	C-101
ND6739R12	C-101
ND6745T12HQ	C-102
ND67T12CG20	C-102
ND6815T12	C-102
ND6818T12	C-102
ND6839R12	C-101
ND6844R12	C-101
ND6845T12HQ	C-102
ND6848T12	C-102
NDR6325AT13	A-117

Alpha-Numeric Index

Catalog Number	Page
NDR6328T13	C-91
NDR6329AR13	A-119
NDR6329AT13	A-117
NDR6332AT13	A-117
NDR6334T13	C-91
NDR6428T16	C-91
NDR6432AT0	A-117
NDR6432AT16	A-117
NDR6434T12	C-91
NDR6434T16	C-91
NDR6436AT16	A-117
NDR6444T16	C-91
NDR64534T14	C-91
NDR6528T14	C-91
NDR6534T12	C-91
NDR6534T14	C-91
NDR6536AT14	A-117
NDR6542AT14	A-117
NDR6544T14	C-91
NDR65528T12	C-91
NDR65529AT0	A-117
NDR65529AT12	A-117
NDR65534T12	C-91
NDR65536AR12	A-119
NDR65536AT12	A-118
NDR65542AR12	A-119
NDR65542AT12	A-118
NDR65544T12	C-91
NDR65545AR12	A-119
NDR65545AT12	A-118
NDR6632AT12	A-118
NDR6636AT12	A-118
NDR6642AT12	A-118
NDR6646AT12	A-118
NDR6732AR12GS	A-119
NDR6732AT12	A-118
NDR6736AT12	A-118
NDR6742AR12	A-119
NDR6742AT12	A-118
NDR6745AT12	A-118
NDR6748AT12	A-118
NDR6748T12	C-91

Catalog Number	Page
NDR67544T12	C-91
NDR67548T12	C-91
NDR6836AT12	A-118
NDR6842AT12	A-118
NDR6844T12	C-91
NDR6845AR12	A-119
NDR6845AT12	A-118
NDR6848T12	C-91
NDR68544T12	C-91
NDXR42A	A-10
NE1328	C-29
NE1426	C-29
NE1428	C-29
NE1429	C-29
NE1526	C-29
NE1528	C-29
NE1534	C-29
NE1544	C-29
NE1634	C-29
NER1430	C-31
NER1530	C-31
NER1534	C-31
NER1634	C-31
NER1734	C-31
NER1744	C-31
NER1840	C-31
NER1844	C-31
NER1944	C-31
NFD675C8	C-88
NFD67C5	C-88
NFD68C5	C-88
NFD68C5W	C-88
NFXR15	C-18, C-79
NFXR15CG20	C-18, C-79
NFXR15CG24	C-18, C-79
NFXR15CG7	C-18, C-79
NFXR15HQ	C-18, C-79
NG19ACG2	A-169
NG21ACG1	A-169
NG24ACG1	A-169
NHNT1429	C-62
NHNT1434	C-62

Catalog Number	Page
NHNT1529	C-62
NHNT1534	C-62
NHNT1540	C-62
NHNT1629	C-62
NHNT1634	C-62
NHNT1640	C-62
NHNT1644	C-62
NHNT1729	C-62
NHNT1734	C-62
NHNT1740	C-62
NHNT1744	C-62
NHNT1829	C-62
NHNT1834	C-62
NHNT1840	C-62
NHNT1844	C-62
NHNT1846	C-62
NHNT1929	C-62
NHNT1934	C-62
NHNT1940	C-62
NHNT1944	C-62
NHNT1946	C-62
NHNT2040	C-62
NHNT2044	C-62
NHNT2229	C-62
NHNT2929	C-61
NHNT3429	C-61
NHNT4429	C-61
NHNT4434	C-61
NHNT4440	C-61
NHNT4444	C-61
NHNT4834	C-61
NHNT4840	C-61
NHNT4846	C-61
NHNT4848	C-61
NL1313HC	C-25
NL1414	C-25
NL14148HC	C-25
NL1515	C-25
NL151545	C-25
NL151545HC	C-25
NL1515HC	C-25
NL15A15A	A-39

Alpha-Numeric Index

Catalog Number	Page
NL1616	C-25
NL161645	C-25
NL16A16A	A-39
NL16A16A45	A-39
NL1717	C-25
NL171745	C-25
NL171745HC	C-25
NL1717HC	C-25
NL17A17A	A-39
NL17A17A45	A-39
NL1818	C-25
NL181845	C-25
NL181845HC	C-25
NL1818HC	C-25
NL18A18A	A-39
NL18A18A45	A-39
NL1919	C-25
NL191945	C-25
NL1919HC	C-25
NL19A19A	A-39
NL19A19A45	A-39
NL202045	C-26
NL2020HC	C-26
NL20A20A	A-39
NL20A20A45	A-39
NL212145	C-26
NL21A21A	A-39
NL21A21A45	A-39
NL2222	C-26
NL222245	C-26
NL22A22A	A-39
NL22A22A45	A-39
NL24A24A	A-39
NL24A24A45	A-39
NL86A86A	A-39
NL86A86A45	A-39
NN2AR36A2N	A-7
NN2AR36A4N	A-7
NN2AR36A4N90	A-8
NN2AR42A4N	A-7
NN2AR42A4N45	A-8
NN2AR42A4N90	A-8

Catalog Number	Page
NN2AR45A44N	A-7
NN2AR45A44N45	A-8
NN2AR45A44N90	A-8
NN2AR45A4N	A-7
NN2AR46A44N	A-7
NN2AR46A44N45	A-8
NN2AR46A44N90	A-8
NN2AR46A4N	A-7
NN2AR486A44N	A-7
NN2AR486A66N	A-7
NN2AR48A44N	A-7
NN2AR48A44N45	A-8
NN2AR48A44N45L6SS	A-8
NN2AR48A44N90	A-8
NN2AR48A4N	A-7
NN2AR48A4N90	A-8
NN2AR48A66N	A-7
NN2BCAH4444N	C-78
NN2ER1944HC	C-33
NN2ER20A45A	A-45
NN2TR18A46AL6	A-89
NN2TR19A42A	A-89
NN2TR19A45A	A-89
NN2TR20A44A	A-89
NN2TR22A44A	A-89
NN2TR22A45A	A-89
NN2TR22A48A	A-89
NN2TR86A45A	A-89
NN3AR32A34N	A-9
NN3AR36A34N	A-9
NN3AR48A44N	A-9
NNBXR1515	C-20, C-36, C-80
NNE14A34A	A-40
NNE15A34A	A-40
NNE18A36AGS	A-40
NNE19A36A	A-40
NNER1434HC	C-32
NNER14A29A	A-41
NNER14A32A	A-41
NNER14A36A	A-41
NNER15A25A	A-41
NNER15A29A	A-41

Catalog Number	Page
NNER15A32A	A-41
NNER15A36A	A-41
NNER15A42A	A-41
NNER1644HC	C-32
NNER16A29A	A-41
NNER16A32A	A-41
NNER16A36A	A-41
NNER16A42A	A-42
NNER16A45A	A-42
NNER1729HC	C-32
NNER17A32A	A-42
NNER17A36A	A-42
NNER17A42A	A-42
NNER17A45A	A-42
NNER17A46A	A-42
NNER17A48A	A-42
NNER1840HC	C-32
NNER18A29A	A-42
NNER18A32A	A-42
NNER18A36A	A-42
NNER18A42A	A-42
NNER18A48A	A-42
NNER19A32A	A-42
NNER20A32A	A-42
NNER20A36A	A-42
NNER20A42A	A-42
NNER20A45A	A-42
NNER20A46A	A-42
NNER22A29A	A-42
NNER22A32A	A-42
NNER22A36A	A-42
NNER22A45A	A-42
NNER22A48A	A-42
NNHN22VVT48640W	C-73
NNR15A14A	A-43
NNR16A15A	A-43
NNR17A14A	A-43
NNR17A15A	A-43
NNR17A16A	A-43
NNR18A14A	A-43
NNR18A15A	A-43
NNR18A16A	A-43

Alpha-Numeric Index

Catalog Number	Page
NNR18A17A	A-43
NNR19A14A	A-43
NNR19A15A	A-43
NNR19A16A	A-43
NNR19A17A	A-43
NNR19A18A	A-43
NNR20A17A	A-43
NNR20A18A	A-43
NNR20A19A	A-43
NNR21A18A	A-43
NNR21A20A	A-43
NNR22A18A	A-43
NNR24A20A	A-43
NNRR29A29A	A-44
NNRR32A29A	A-44
NNRR36A29A	A-44
NNRR36A36A	A-44
NNRR42A29A	A-44
NNRR42A36A	A-44
NNRR42A42A	A-44
NNRR48A42A	A-44
NNRR48A48A	A-44
NNT14A14A	A-81
NNT14A14A75	A-110
NNT15A14A	A-81
NNT15A15A	A-81
NNT16A14A	A-81
NNT16A14A75	A-110
NNT16A15A	A-81
NNT16A15A75	A-110
NNT16A16A	A-81
NNT17A14A	A-81
NNT17A15A	A-81
NNT17A15A75	A-110
NNT17A17A	A-81
NNT18A14A	A-81
NNT18A15A	A-81
NNT18A15A75	A-110
NNT18A16A	A-81
NNT18A16A75	A-110
NNT18A17A	A-81
NNT18A18A	A-81

Catalog Number	Page
NNT18A18A75	A-110
NNT19A14A	A-81
NNT19A15A	A-81
NNT19A16A	A-81
NNT19A17A	A-81
NNT19A17A75	A-110
NNT19A18A	A-81
NNT19A18A75	A-110
NNT19A19A	A-81
NNT19A19A75	A-110
NNT20A15A	A-82
NNT20A16A	A-82
NNT20A17A	A-82
NNT20A17A75	A-110
NNT20A17A80	A-110
NNT20A18A	A-82
NNT20A19A	A-82
NNT20A20A	A-82
NNT21A17A	A-82
NNT21A17A75	A-110
NNT21A18A	A-82
NNT21A18A75	A-110
NNT21A18A80	A-110
NNT21A19A	A-82
NNT21A19A75	A-110
NNT21A20A	A-82
NNT21A21A	A-82
NNT22A15A	A-82
NNT22A16A	A-82
NNT22A17A	A-82
NNT22A17A75	A-110
NNT22A18A	A-82
NNT22A18A80	A-110
NNT22A19A	A-82
NNT22A19A75	A-110
NNT22A19A80	A-110
NNT22A22A	A-82
NNT24A18A	A-82
NNT24A19A	A-82
NNT24A19A75	A-110
NNT24A20A	A-82
NNT24A21A75	A-110

Catalog Number	Page
NNT24A22A	A-82
NNT24A24A	A-82
NNT86A18A	A-82
NNT86A20A	A-82
NNT86A20A75	A-110
NNT86A22A	A-82
NNT86A86A	A-82
NNTR13A25A	A-86
NNTR14A25A	A-86
NNTR14A29A	A-86
NNTR14A32A	A-86
NNTR15A25A	A-86
NNTR15A29A	A-86
NNTR15A32A	A-86
NNTR15A36A	A-86
NNTR15A42A	A-86
NNTR16A29A	A-86
NNTR16A32A	A-86
NNTR16A36A	A-86
NNTR16A42A	A-86
NNTR17A29A	A-87
NNTR17A32A	A-87
NNTR17A36A	A-87
NNTR17A42A	A-87
NNTR17A45A	A-87
NNTR17A48A	A-87
NNTR18A29A	A-87
NNTR18A32A	A-87
NNTR18A36A	A-87
NNTR18A42A	A-87
NNTR18A45A	A-87
NNTR19A29A	A-87
NNTR19A32A	A-87
NNTR19A36A	A-87
NNTR19A42A	A-87
NNTR19A45A	A-87
NNTR19A46A	A-87
NNTR19A48A	A-87
NNTR20A29A	A-87
NNTR20A32A	A-87
NNTR20A36A	A-87
NNTR20A42A	A-87

Alpha-Numeric Index

Catalog Number	Page
NNTR20A45A	A-87
NNTR20A46A	A-87
NNTR20A48A	A-87
NNTR21A32A	A-88
NNTR21A36A	A-88
NNTR21A42A	A-88
NNTR22A29A	A-88
NNTR22A32A	A-88
NNTR22A36A	A-88
NNTR22A42A	A-88
NNTR22A45A	A-88
NNTR22A46A	A-88
NNTR22A48A	A-88
NNTR25A25A	A-83
NNTR29A29A	A-83
NNTR32A25A	A-83, A-86
NNTR32A29A	A-83
NNTR32A32A	A-83
NNTR36A25A	A-83
NNTR36A29A	A-83
NNTR36A32A	A-83
NNTR36A36A	A-83
NNTR42A25A	A-83
NNTR42A29A	A-84
NNTR42A32A	A-84
NNTR42A36A	A-84
NNTR42A42A	A-84
NNTR45A25A	A-84
NNTR45A29A	A-84
NNTR45A32A	A-84
NNTR45A36A	A-84
NNTR45A42A	A-84
NNTR45A45A	A-84
NNTR46A25A	A-84
NNTR46A29A	A-84
NNTR46A32A	A-84
NNTR46A36A	A-84
NNTR46A42A	A-84
NNTR46A45A	A-84
NNTR46A46A	A-84
NNTR486A36A	A-85
NNTR48A36A	A-85

Catalog Number	Page
NNTR48A42A	A-85
NNTR48A46A	A-85
NNTR48A486A	A-85
NNTR48A48A	A-85
NR1413	C-28
NR1514	C-28
NR1614HC	C-28
NR1716	C-28
NR1814HC	C-28
NR1815	C-28
NR1817	C-28
NS1212	C-23
NS1313	C-23
NS14148HC	C-23
NS1414HC	C-23
NS14A14A	A-46
NS1515	C-23
NS1515HC	C-23
NS1515HCHQ	C-23
NS15A15A	A-46
NS1616HC	C-23
NS16A16A	A-46
NS1717	C-23
NS1717HC	C-23
NS1717HCHQ	C-23
NS17A17A	A-46
NS1818	C-23
NS1818CG2	C-23
NS1818HC	C-23
NS18A18A	A-46
NS1919	C-23
NS1919HC	C-23
NS1919HCHQ	C-23
NS19A19A	A-46
NS2020	C-23
NS2020HC	C-23
NS20A20A	A-46
NS2121	C-23
NS2121HC	C-23
NS21A21A	A-46
NS2222	C-23
NS2222HC	C-23

Catalog Number	Page
NS22A22A	A-46
NS23A23A	A-46
NS24A24A	A-46
NS2626	C-24
NS2727	C-24
NS2828	C-24
NS3434	C-24
NS4444	C-24
NS4545	C-24
NS4848	C-24
NS86A86A	A-46
NSH153	C-53
NSH163	C-53
NSH183	C-53
NSH185	C-53
NSH203	C-53
NSH205	C-53
NSHG16A3	A-47, A-69
NSHG17A3	A-47, A-69
NSHG18A3	A-47, A-69
NSHG18A5	A-47, A-69
NSHG19A3	A-47, A-69
NSHG20A5	A-47, A-69
NSHG21A5	A-47, A-69
NSHG22A5	A-47, A-69
NSNT1329	C-60
NSNT1429	C-60
NSNT1434	C-60
NSNT1529	C-60
NSNT1629	C-60
NSNT2929	C-60
NSNT3429	C-60
NSNT3434	C-60
NT1212	C-57
NT1313	C-57
NT1413	C-57
NT1414	C-57
NT1414HC	C-57
NT1514	C-57
NT1515	C-57
NT1515HC	C-57
NT1515HQ	C-57

Alpha-Numeric Index

Catalog Number	Page
NT1613	C-57
NT1614	C-57
NT1615	C-57
NT1615HC	C-57
NT1616	C-57
NT1616HC	C-57
NT1713	C-57
NT1714	C-57
NT1715	C-57
NT1715HQ	C-57
NT1716	C-57
NT1717	C-57
NT1717HC	C-57
NT1717HQ	C-57
NT1744HQ	C-57
NT1813	C-58
NT1814	C-58
NT18148HC	C-58, C-59
NT1815	C-58
NT1816	C-58
NT181675	C-82
NT1817	C-58
NT1818	C-58
NT18188HC	C-58, C-59
NT1820	C-58
NT1914	C-58
NT1914HC	C-58
NT1916	C-58
NT1917	C-58
NT1919	C-58
NT19198HC	C-58, C-59
NT1919HC	C-58
NT1919HQ	C-58
NT1944HQ	C-58
NT2014	C-58
NT2016	C-58
NT201675	C-82
NT2017	C-58
NT2018	C-58
NT2020	C-58
NT2020HC	C-58
NT2121	C-58

Catalog Number	Page
NT22188HC	C-59
NT2220	C-58
NT2222	C-58
NT22228HC	C-59
NTB17AG1	A-170
NTB18AG1	A-170
NTB19AG1	A-170
NTB20AG1	A-170
NTB22AG1	A-170
NTB24AG1	A-170
NTB86AG1	A-170
NVH14A3	A-68
NVH15A3	A-68
NVH15A5	A-68
NVH175	C-52
NVH17A3	A-68
NVH183	C-52
NVH18A3	A-68
NVH18A5	A-68
NVH22A3	A-68
NVT1328	C-71
NVT1330	C-71
NVT1428	C-71
NVT1434	C-71
NVT1528	C-71
NVT1534	C-71
NVT1728	C-71
NVT1828	C-71
NVT1944	C-71
NVTT1325	C-72
NVTT1428	C-72
NVTT1434	C-72
NVTT1528	C-72
NVTT1534	C-72
NVTT1540	C-72
NVTT1630	C-72
NVTT1634	C-72
NVTT1828	C-72
NVTT1830	C-72
NVTT1844	C-72
NVTT1928	C-72
NVTT2028	C-72

Catalog Number	Page
NVTT2040	C-72
NVTT2044	C-72
NVVE1434	C-30
NVVE1844	C-30
NY2T44G1	C-76
NY2T46G1	C-76
NYT2526	C-74
NYT2626	C-74
NYT2725	C-74
NYT2825	C-74
NYT2826	C-74
NYT2828	C-74
NYT282C	C-74
NYT2925	C-74
NYT2929	C-74
NYT3125	C-74
NYT3128	C-74
NYT3131	C-74
NYT3426	C-74
NYT3428	C-74
NYT3429	C-74
NYT3431	C-74
NYT3434	C-74
NYT3928	C-75
NYT3929	C-75
NYT3931	C-75
NYT3934	C-75
NYT4429	C-75
NYT4431	C-75
NYT4434	C-75
NYT4439	C-75
NYT4444	C-75
NYT4628	C-75
NYT4634	C-75
NYT4639	C-75
NYT4644	C-75
NYT4646	C-75
NYT4834	C-75
NYT4844	C-75
NYT4848	C-75
OH17A3	A-67
OH17A5	A-67

Alpha-Numeric Index

Catalog Number	Page
OH18A3	A-67
OH18A5	A-67
OH19A3B	A-67
OH19A5	A-67
OH20A3	A-67
OH20A5	A-67
OH21A3	A-67
OH21A5	A-67
OH22A5	A-67
OH86A5	A-67
QGFL1CB1	C-120
QGFL1CB1T6	C-120
QGFL26B1	C-120
QGFL26B1T6	C-120
QGFL26B2	C-120
QGFL26B2T6	C-120
QGFL29B1	C-120
QGFL29B1T6	C-120
QGFL31B1	C-120
QGFL31B1T6	C-120
QGFL34B1	C-120
QGFL34B1T6	C-120
QGFL39B1	C-120
QGFL39B1T6	C-120
QGFL44B1	C-120
QGFL44B1T6	C-120
QGFL46B1	C-120
QGFL46B1T6	C-120
QGFL48B1	C-120
RHA153HQ	C-44
RHA173HQ	C-44
RHA175HQ	C-44
RHA193HQ	C-44
RHA195CG1	C-44
RHA195HQ	C-44
RHB343HQ	C-46
RHB453	C-46
RHB453HQ	C-46
RHB455	C-46
RHB455HQ	C-46
S2GBP36A	A-137
S2GBP36A8	A-137

Catalog Number	Page
S2GBP41A	A-137
S2GBP41A12	A-137
S2GBP41A12B2	A-139
S2GBP41A12B4	A-140
S2GBP41A8	A-137
S2GBP41AB2	A-139
S2GBP41AB4	A-140
S2GBP445A	A-137
S2GBP445A12	A-137
S2GBP445A12B2	A-139
S2GBP445A12B4	A-140
S2GBP445A16	A-137
S2GBP445A8	A-137
S2GBP445A8B2	A-139
S2GBP445AB2	A-139
S2GBP445AB4	A-140
S2GBP44A	A-137
S2GBP44A12B2	A-139
S2GBP44A12B4	A-140
S2GBP44A8	A-137
S2GBP44A9	A-137
S2GBP44AB4	A-140
S2GBP45A	A-137
S2GBP45A12	A-138
S2GBP45A12B2	A-139
S2GBP45A12B4	A-140
S2GBP45AB4	A-140
S2GBP46A	A-138
S2GBP46A12	A-138
S2GBP46A12B2	A-139
S2GBP46A12B4	A-140
S2GBP46A8	A-138
S2GBP46A9	A-138
S2GBP483A	A-138
S2GBP483A12	A-138
S2GBP483A12B2	A-139
S2GBP483A12B4	A-140
S2GBP483A8	A-138
S2GBP483AB4	A-140
S2GBP486A	A-138
S2GBP486A12	A-138
S2GBP486A12B2	A-139

Catalog Number	Page
S2GBP486A12B4	A-140
S2GBP486A13	A-138
S2GBP486A18B2	A-139
S2GBP486A8	A-138
S2GBP486A9B2	A-139
S2GBP486AB4	A-140
S2GBP48A	A-138
S2GBP48A12	A-138
S2GBP48A12B2	A-139
S2GBP48A12B2SS	A-139
S2GBP48A12B4	A-140
S2GBP48A8	A-138
S2GBP48AB2	A-139
S2GBP48AB4	A-140
S2GBPA36A8	A-33, A-104, A-142
S2GBPA41A12B4	A-35, A-106, A-144
S2GBPA445A	A-33, A-104, A-142
S2GBPA445A12B4	A-35, A-106, A-144
S2GBPA445AB4	A-35, A-106, A-144
S2GBPA44A	A-33, A-104, A-142
S2GBPA44A12	A-33, A-104, A-142
S2GBPA44A12B2	A-34, A-105, A-143
S2GBPA44A12B4	A-35, A-106, A-144
S2GBPA44A8	A-33, A-104, A-142
S2GBPA44AB4	A-35, A-106, A-144
S2GBPA45A	A-33, A-104, A-142
S2GBPA45A12	A-33, A-104, A-142
S2GBPA45A12B2	A-34, A-105, A-143
S2GBPA45A12B4	A-35, A-106, A-144
S2GBPA45AB2	A-34, A-105, A-143
S2GBPA46A12	A-33, A-104, A-142
S2GBPA46A12B4	A-35, A-106, A-144
S2GBPA46A8	A-33, A-104, A-142
S2GBPA483A12B4	A-35, A-106, A-144
S2GBPA483AB4	A-35, A-106, A-144
S2GBPA486A	A-138
S2GBPA486A12	A-33, A-104, A-142
S2GBPA486A12B2	A-34, A-105, A-143
S2GBPA486A12B4	A-35, A-106, A-144
S2GBPA486A8	A-138
S2GBPA486AB4	A-35, A-106, A-144
S2GBPA48A	A-33, A-104, A-142

Alpha-Numeric Index

Catalog Number	Page
S2GBPA48A10	A-33, A-104, A-142
S2GBPA48A12	A-33, A-104, A-142
S2GBPA48A12B2	A-34, A-105, A-143
S2GBPA48A12B4	A-35, A-106, A-144
S2GBPA48A8	A-33, A-104, A-142
S2GGBP445A12	A-141, A-174
S2GGBP486A	A-141, A-174
S2GGBP486A9	A-141, A-174
S2GGBP48A	A-141, A-174
S2GGBP48A12	A-141, A-174
S3GBP41A	A-149
S3GBP445A	A-149
S3GBP445AB2	A-149
S3GBP44A	A-149
S3GBP45A	A-149
S3GBP46A	A-149
S3GBP483A	A-149
S3GBP486A	A-149
S3GBP486A8	A-149
S3GBP48A	A-149
S3GBP48AB2	A-149
S3GBP495A8B2	A-151
S3GBPA445A	A-150
S3GBPA44A	A-150
S3GBPA45A	A-150
S3GBPA48A	A-150
S3GGBP445A	A-153, A-175
S4GBP48A	A-154
S4GBP48A12	A-154
SAT2419A30345	A-111
SCB18A	A-164, A-259
SCB19A	A-164, A-259
SCB20A	A-164, A-259
SCB21A	A-164, A-259
SCB22A	A-164, A-259
SCB24A	A-164, A-259
SCB83A	A-164, A-259
SCB86A	A-164, A-259
SCBB20A	A-165, A-260
SCBB21A	A-165, A-260
SCBB24A	A-165, A-260
SCBB86A	A-165, A-260

Catalog Number	Page
SCBB88A	A-165, A-260
SF2A44NL12EX	A-31
SF3A44N8	A-32
SF3A44N866N	A-32
SFD67D12	A-124
SFD68AD16	A-124
SFD69AD16	A-124
SFD70AD16	A-124
SFD71AD16	A-124
SFD71AD20	A-124
SFD72AD18	A-124
SFD72AD20	A-124
SH2GBP41A5	A-77, A-145
SH2GBP41A512	A-77, A-145
SH2GBP41A512B2	A-75, A-146
SH2GBP41A712B2	A-75, A-146
SH2GBP445A512	A-77, A-145
SH2GBP445A512B2	A-75, A-146
SH2GBP445A515B4	A-76, A-147
SH2GBP44A512B2	A-75, A-146
SH2GBP44A512B4	A-76, A-147
SH2GBP45A5	A-77, A-145
SH2GBP45A512	A-77, A-145
SH2GBP45A512B2	A-75, A-146
SH2GBP46A5	A-77, A-145
SH2GBP46A512	A-77, A-145
SH2GBP46A512B4	A-76, A-147
SH2GBP486A5B2	A-75, A-146
SH2GBP486A5B4	A-76, A-147
SH2GBP486A7	A-77, A-145
SH2GBP48A5	A-77, A-145
SH2GBP48A512	A-77, A-145
SH2GBP48A512B2	A-75, A-146
SH2GBP48A512B4	A-76, A-147
SH2GBP48A5B2	A-75, A-146
SH2GBP48A5B4	A-76, A-147
SH2GBP48A7	A-77, A-145
SH2GBP48A712B2	A-75, A-146
SH2GBP48A7B2	A-75, A-146
SH2GBP495A58	A-77, A-145
SH3GBP445A5B2	A-152
SH3GBP44A5	A-152

Catalog Number	Page
SH3GBP45A5	A-152
SH3GBP45A5B2	A-152
SH3GBP46A5	A-152
SH3GBP48A5	A-152
SH3GBP48A5B2	A-152
SH4GBP48A5	A-155
SN2A445A4N	A-25
SN2A44A44N	A-25
SN2A44A4N	A-25
SN2A45A44N	A-25
SN2A45A4N	A-25
SN2A47A44NS3HQ	A-23
SN2A48A44N	A-25
SN2A48A4NGS	A-25
SN2A496A44NS7HQ	A-26
SN2A496A66NS7HQ	A-26
SN2B496A44N90RS7	A-103
SN2D6847AR1215S3	A-128
SN2D6847AT1215S3	A-129
SN2D68496AR015S7SS	A-127
SN2D68496AR1215S7SS	A-127
SN2D70496AT1215S7	A-130
SN2GB486ACG1	A-173
SN2GB495A12SSDN	A-173
SN2GB495ASSDN	A-173
SN2GB496A15HQ	A-173
SN2GB496ACG1	A-173
SNA22ACG2	A-28
SNA41A44N45S3SS	A-20
SNA41A44N90S3SS	A-20
SNA41A44NS3SS	A-20
SNA44A44N	A-21
SNA44A4N	A-21
SNA45A4NGS	A-21
SNA46A44NGS	A-21
SNA46A4NGS	A-21
SNA47A44N90S3	A-20
SNA47A44NS3HQ	A-20
SNA486A44N	A-21
SNA486A4N	A-21
SNA48A44N	A-21
SNA48A46NGS	A-21

Alpha-Numeric Index

Catalog Number	Page
SNA496A44NS7	A-22
SNA496A66NS7	A-22
SNA86A4N	A-28
SNAC22A4N	A-29
SNAC486A44N	A-29
SNAC86A44NSTS	A-29
SNBC22A44NSTS	A-101
SNBC22A4N	A-101
SNBC45A44N	A-101
SNBC47A44NS3	A-100
SNBC486A44N	A-101
SNBC486A4N	A-101
SNBC496A44NS7HQ	A-101, A-102
SNBC86A44N	A-101
SNBC86A44NS7SS	A-101, A-102
SNCB20A	A-171
SNCB22A	A-171
SNCB24A	A-171
SNCB86A	A-171
SND6741AR12S3SS	A-125
SND6744AR12S3GS	A-125
SND6744AT12S3GS	A-126
SND6747AR12S3HQ	A-125
SND6747AT12S3HQ	A-126
SND6847AT12S3HQ	A-126
SNE22ACG2	A-53
SNG21ACG1	A-172
SNN2A44A44N	A-27
SNN2A44A66NL6	A-27
SNN2A46A66NL13GS	A-27
SNN2A486A44N90S3L13GS	A-24
SNN2A486A44NS3L13GS	A-24
SNN2A48A66NL13GS	A-27
SNN2D68486AT12L13BCH	A-131
SNN2D6848AT0L13GS	A-131
SNN2D69495AT12L6S2BCH	A-131
SNN2D70495AT12L6S2BCH	A-131
SNN2E22A44AS3L6GS	A-55
SNN2E22A495AS2L13GS	A-55
SNNE19A48AG1	A-54
SNNR86A22A	A-56
SNNS24A24A	A-52

Catalog Number	Page
SNNS86A86A	A-52
SNNT20A20A	A-96
SNNT22A20A	A-96
SNNT22A22A	A-96
SNNT24A24A	A-96
SNNT24A486A	A-96
SNNT44A44AS3	A-97
SNNT45A46AS3	A-97
SNNT45A47AS3	A-97
SNNT46A486AS3	A-97
SNNT47A47AS3	A-97
SNNT496A44AS7	A-98
SNNT496A47AS7	A-98
SNNT496A496AS7	A-98
SNNT496A53RS7	A-98
SNNT86A20A80GS	A-112
SNNT86A48AGS	A-96
SNNTV20A20AGS	A-99
SNNTV23A23AS7GS	A-99
SNS19ACG1	A-51
SNS20ACG2	A-51
SNS21ACG1	A-51
SNS22ACG2	A-51
SNS23ACG1	A-51
SNS83A83A	A-51
SNS86ACG1	A-51
SR701826	A-166
SR701830	A-166
SR70201	A-166
SR70203	A-166
SR70204	A-166
SR70253	A-166
SR70254	A-166
SR70256	A-166
SR702561	A-166
SR702562	A-166
SR702563	A-166
SR702564	A-166
SR702565	A-166
SR702566	A-166
SR702567	A-166
SR702568	A-166

Catalog Number	Page
SR702569	A-166
SR705321HQ	A-166
SR705322HQ	A-166
SSXHP22A10HQ	A-59, A-72
SSXHP83A5	A-59, A-72
SSXHP83A7	A-59, A-72
SSXHP86A10HQ	A-59, A-72
STS33A-4N	A-159
STS33A4NCG1	A-160
STS43A-4N	A-159
STS44A-4N	A-159
STS44A4NCG1	A-160
STS44A-4NCG2	A-160
STS44ACG10	A-160
STS44ACG7	A-160
STS46A6NCG1	A-160
SUHG20A5	A-71
SUHG20ACG6	A-71
SUHG20ACG6GS	A-71
SUHG21A7	A-71
SUHG22A10HQ	A-71
SUHG22A5	A-71
SUHG22A7	A-71
SUHG22ACG4	A-71
SUHG23A5CG1	A-71
SUHG24A5	A-71
SUHG24A5CG2	A-71
SUHG24A7	A-71
SUHG24A7GS	A-71
SUHG83A5	A-71
SUHG83A7	A-71
SUHG86A10B	A-71
SUHG86A10HQ	A-71
SUHG86A5	A-71
SUHG86A7	A-71
SUHK44ACG8	A-70
SUHK46A5CG5	A-70
SUHK47A10S3HQ	A-70
SUHK486ACG2	A-70
SUHK48A5S3HQ	A-70
SUHK496A10S7HQ	A-70
SUHK496ACG2	A-70

Alpha-Numeric Index

Catalog Number	Page
SW2A20A44NG3	A-203
SW2A22A44NG3	A-203
SW2A24A44NG3	A-203
SW2A24A46NG3	A-203
SW2A444A44N	A-194
SW2A444A44N90	A-194, A-195
SW2A44R44N90STS	A-194, A-195
SW2A486A44N	A-194
SW2A486A44N90	A-194, A-195
SW2A486A66N90	A-194, A-195
SW2A48A44N	A-194
SW2A58R44N	A-194
SW2A83A46NG3	A-203
SW2A86A44NG3	A-203
SW2T24ACG2	A-242
SW3A22A44N8	A-202
SW3A24A44N8	A-202
SW3A454A44NSTS	A-196
SW3A83A44N8	A-202
SW3A86A44N8	A-202
SW3AB20A44N8	A-241
SW3AB22A44N8	A-241
SW3AB24A44N8	A-241
SW3AB83A44N8	A-241
SW3AB86A44N8	A-241
SWA15A34N90	A-198
SWA16A2N90	A-198
SWA17A2N90	A-198
SWA18A2N	A-197
SWA18A2N90	A-198
SWA18A-34N	A-197
SWA18A34N90	A-198
SWA18A44N	A-197
SWA18A44N90	A-198
SWA19A34N	A-197
SWA19A34N90	A-198
SWA19A44N	A-197
SWA19A44N90	A-198
SWA20A-2N	A-197
SWA20A34N90	A-198
SWA21A-44N	A-197
SWA21A44N90	A-198

Catalog Number	Page
SWA22A34N	A-197
SWA22A44N	A-197
SWA22A44N90	A-198
SWA24A44N	A-197
SWA24A44N90	A-198
SWA24A66N90	A-198
SWA444A-44N	A-192
SWA486A-44N	A-192
SWA486A44N90	A-193
SWA48A44N90	A-193
SWA86A44N	A-197
SWA86A44N90	A-198
SWA86A66N90	A-198
SWA90A-34N	A-197
SWA92A-44N	A-197
SWA92A44N90	A-198
SWAB19A2N	A-239
SWAB19A-34N	A-239
SWAB22A2N	A-239
SWAB22A-34N	A-239
SWAB22A-44N	A-239
SWAB86A2N	A-239
SWAB86A34N	A-239
SWAB86A-44N	A-239
SWAC18A2N	A-199
SWAC18A34N	A-199
SWAC18A44N	A-199
SWAC19A2N	A-199
SWAC19A34N	A-199
SWAC19A44N	A-199
SWAC20A2N	A-199
SWAC20A34N	A-199
SWAC20A44N	A-199
SWAC21A34N	A-199
SWAC21A44N	A-199
SWAC22A34N	A-199
SWAC22A44N	A-199
SWAC23A34N	A-199
SWAC23A44N	A-199
SWAC24A34N	A-199
SWAC24A44N	A-199
SWAC58A34N	A-199

Catalog Number	Page
SWAC83A44N	A-199
SWAC86A44N	A-199
SWAC86A66N	A-199
SWAC90A34N	A-200
SWAC92A44N	A-200
SWAC94A44N	A-200
SWAC96A44N	A-200
SWACC22A4N	A-201
SWACC90A4N	A-201
SWAT18A15A30	A-245
SWAT18A16A30	A-245
SWAT18A17A-30	A-245
SWAT18A18A30	A-245
SWAT19A16A-30	A-245
SWAT19A17A20	A-245
SWAT19A17A-30	A-245
SWAT19A18A30	A-245
SWAT19A19A30	A-245
SWAT20A17A-30	A-245
SWAT20A18A-30	A-245
SWAT20A19A20	A-245
SWAT20A19A30	A-245
SWAT20A20A30	A-245
SWAT21A16A30	A-245
SWAT21A17A30	A-245
SWAT21A18A-30	A-245
SWAT21A19A30	A-245
SWAT21A20A30	A-245
SWAT21A21A30	A-245
SWAT22A18A30	A-245
SWAT22A19A20	A-246
SWAT22A19A30	A-246
SWAT22A20A30	A-246
SWAT22A22A30	A-246
SWAT24A18A30	A-246
SWAT24A19A30	A-246
SWAT24A20A20	A-246
SWAT24A20A-30	A-246
SWAT24A21A30	A-246
SWAT24A22A30	A-246
SWAT86A19A30	A-246
SWAT86A20A30	A-246

Alpha-Numeric Index

Catalog Number	Page
SWAT86A21A20	A-246
SWAT86A21A30	A-246
SWAT86A22A-30	A-246
SWCB19A	A-263
SWCB20A	A-263
SWCB22A	A-263
SWCB23A	A-263
SWCB24A	A-263
SWCB83A	A-263
SWCB86A	A-263
SWCB88A	A-263
SWHRH18A3CH	A-229
SWHRH18A5CH	A-229
SWHRH19A3CH	A-229
SWHRH19A5CH	A-229
SWHRH20A3CH	A-229
SWHRH20A5CH	A-229
SWHRH21A3CH	A-229
SWHRH21A5CH	A-229
SWHRH22A3CH	A-229
SWHRH22A5CH	A-229
SWHRH24A3CH	A-229
SWHRH24A5CH	A-229
SWHRH86A3CH	A-229
SWHRH86A5CH	A-229
SWL14A	A-217
SWL17A	A-217
SWL18A	A-217
SWL19A	A-217
SWL20A	A-217
SWL21A	A-217
SWL22A	A-217
SWL24A	A-217
SWL58A	A-217
SWL59A	A-217
SWL86A	A-217
SWL96A	A-217
SWOH18A5	A-230
SWOH19A3	A-230
SWOH19A5	A-230
SWOH20A3	A-230
SWOH20A5	A-230

Catalog Number	Page
SWOH21A5	A-230
SWOH22A3	A-230
SWOH22A5	A-230
SWOH24A5	A-230
SWOH86A5	A-230
SWR24A21A	A-219
SWR24A22A	A-219
SWSUH18A3	A-231
SWSUH18A5	A-231
SWSUH19A3	A-231
SWSUH19A5	A-231
SWSUH20A3	A-231
SWSUH20A5	A-231
SWSUH21A3	A-231
SWSUH21A5	A-231
SWSUH22A-3	A-231
SWSUH22A5	A-231
SWSUH22A7	A-231
SWSUH24A5	A-231
SWSUH86A-5	A-231
SWT17A15A	A-240
SWT17A16A	A-240
SWT17A17A	A-240
SWT18A15A75	A-247
SWT18A18A75	A-247
SWT19A17A75	A-247
SWT19A17A80	A-248
SWT19A18A75	A-247
SWT19A19A	A-240
SWT19A19A75	A-247
SWT20A17A75	A-247
SWT20A18A75	A-247
SWT20A18A80	A-248
SWT20A19A80	A-248
SWT20A20A75	A-247
SWT20A20A80	A-248
SWT21A15A	A-240
SWT21A16A75	A-247
SWT21A17A	A-240
SWT21A18A	A-240
SWT21A18A75	A-247
SWT21A19A	A-240

Catalog Number	Page
SWT21A19A75	A-247
SWT21A20A	A-240
SWT21A21A	A-240
SWT21A21A75	A-247
SWT22A15A	A-240
SWT22A17A75	A-247
SWT22A18A	A-240
SWT22A18A75	A-247
SWT22A19A	A-240
SWT22A19A75	A-247
SWT22A19A80	A-248
SWT22A20A75	A-247
SWT22A20A80	A-248
SWT22A22A	A-240
SWT22A22A75	A-247
SWT24A19A75	A-247
SWT24A20A	A-240
SWT24A20A75	A-247
SWT24A20A80	A-248
SWT24A21A75	A-247
SWT24A22A	A-240
SWT24A22A75	A-247
SWT24A24A	A-240
SWT86A20A75	A-247
SWT86A21A75	A-247
SWT86A21A80	A-248
SWT86A22A75	A-247
SWT86A24A75	A-247
SWT86A86A	A-240
SWVH20A5	A-232
SWVH22A-5	A-232
SWVH22A-7	A-232
SWVH24A5	A-232
SWVH24A7	A-232
SWVH86A5	A-232
SWVH86A7	A-232
SWXA19A4NK8	A-204
SWXA20A4N	A-206
SWXA20A4NK8	A-204
SWXA22A44N	A-206
SWXA22A4N	A-206
SWXA24A44N	A-206

Alpha-Numeric Index

Catalog Number	Page
SWXA24A4N	A-206
SWXA24A66N	A-206
SWXA86A44N	A-206
SWXA86A44NR90	A-207
SWXA86A44NR90KG1	A-204, A-205
SWXA86A4N	A-206
SWXA86A66N	A-206
SWXA92A4N	A-206
SWXA92A66N	A-206
SWXA94A4N	A-206
SWXA94A4NK8	A-204
SWXA94A66N	A-206
SWXA94A6N	A-206
SWXA96A4NK8	A-204
SWXHP19A5	A-221, A-233
SWXHP20A5	A-221, A-233
SWXHP21A5	A-221, A-233
SWXHP22A5	A-221, A-233
SWXHP24A5	A-221, A-233
SWXHP59A5	A-221, A-233
SWXHP86A5	A-221, A-233
SWXHP90A5	A-221, A-233
SWXHP91A5	A-221, A-233
SWXHP92A5	A-221, A-233
SWXHP94A5	A-221, A-233
SWXHP96A5	A-221, A-233
SWXP20A20A	A-220
SWXP22A22A	A-220
SWXP24A24A	A-220
SWXP83A83A	A-220
SWXP86A86A	A-220
SWXP90A90A	A-220
SWXP92A92A	A-220
SWXP94A94A	A-220
SWXP96A96A	A-220
SWXT23ACG1	A-243
SXA86A4NGS	A-30
SXD6821AT12CG1	A-132
SXHP94A5	A-58, A-74
SXP22ACG1	A-57
SXP86ACG2	A-57
U2HKR13A3	A-64

Catalog Number	Page
U2HKR13A5	A-64
U2HKR14A3	A-64
U2HKR14A5	A-64
U2HKR16A3	A-64
U2HKR16A5	A-64
U2HKR17A5	A-64
U2HR153	C-50
U2HR155	C-50
U2HR173	C-50
U2HR175	C-50
U2HR17A3	A-64
UH133	C-43
UH135	C-43
UH143	C-43
UH145	C-43
UH153	C-43
UH155	C-43
UH163	C-43
UH165	C-43
UH173	C-43
UH175	C-43
UH183	C-43
UH185	C-43
UH193	C-43
UH195	C-43
UH203	C-43
UH205	C-43
UH213	C-43
UH215	C-43
UH223	C-43
UH225	C-43
UHG13A3CH	A-65
UHG14A-3	A-65
UHG14A3CH	A-65
UHG15A-3	A-65
UHG15A3CH	A-65
UHG15A-5	A-65
UHG15A5CH	A-65
UHG16A3CH	A-65
UHG16A5CH	A-65
UHG17A-3	A-65
UHG17A3CH	A-65

Catalog Number	Page
UHG17A-5	A-65
UHG17A5CH	A-65
UHG18A-3	A-65
UHG18A3CH	A-65
UHG18A-5	A-65
UHG18A5CH	A-65
UHG19A-3	A-65
UHG19A3CH	A-65
UHG19A5CH	A-65
UHG20A3CH	A-66
UHG20A-5	A-66
UHG20A5CH	A-66
UHG20A7CH	A-66
UHG21A-3	A-66
UHG21A3CH	A-66
UHG21A5CH	A-66
UHG22A3CH	A-66
UHG22A-5	A-66
UHG22A5CH	A-66
UHG24A-3	A-66
UHG24A3CH	A-66
UHG24A-5	A-66
UHG24A5CH	A-66
UHG83A5	A-66
UHG86A5CH	A-66
UHKR11A3	A-63
UHKR11A5	A-63
UHKR13A3	A-63
UHKR13A5	A-63
UHKR14A3	A-63
UHKR14A5	A-63
UHKR16A3	A-63
UHKR16A5	A-63
UHKR17A3	A-63
UHKR17A5	A-63
UHR133	C-45
UHR135	C-45
UHR153	C-45
UHR153SS	C-45
UHR155	C-45
UHR173	C-45
UHR175	C-45

Alpha-Numeric Index

Catalog Number	Page
UHR183	C-45
UHR185	C-45
VA25	C-12
VA252	C-12
VA28	C-12
VA282N	C-12
VA2C	C-12
VA30	C-12
VA302N	C-12
VA34	C-12
VA342N	C-12
VA344	C-12
VA40	C-12
VA402N	C-12
VA404	C-12
VA404N	C-12
VA44	C-12
VA444	C-12
VA462N	C-12
VA4C	C-12
VF28	C-16
VF30	C-16
VF34	C-16
VF40	C-16
VP4634	C-27
VR2525	C-34
VR2825	C-34
VR2828	C-34
VR3030	C-34
VR3428	C-34
VR3430	C-34
VR3434	C-34
VR4040	C-34
VR4444	C-34
VR4646	C-34
VT2828	C-66
VT3028	C-66
VT4034	C-66
VT4430	C-66
VT4434	C-66
VT4440	C-66
VT4444	C-66

Catalog Number	Page
VT4628	C-66
VT4630	C-66
VT4640	C-66
VT4830	C-66
VT4840	C-66
VT4844	C-66
VT4848	C-66
VTT2828	C-67
VTT3030	C-67
VTT3428	C-67
VTT3430	C-67
VTT3434	C-67
VTT4028	C-67
VTT4034	C-67
VTT4040	C-67
VTT4428	C-67
VTT4430	C-67
VTT4444	C-67
VTT4630	C-67
VTT4646	C-67
VV21TT4040	C-69
VV22TT4040	C-70
VV22TT4444	C-70
VV2A344N	C-14
VV2A34CG1	C-14
VV2A4044N	C-14
VV2A46CG1	C-14
VV2D6740R12	C-96
VV2D6740T12	C-97
VV2D6746R12	C-96
VV2D6746T12	C-97
VV2D6846R12	C-96
VV2D6946T12	C-97
VV2D7044R12	C-96
VV3A46CG1	C-15
VV3A46CG2	C-15
VV3A46CG3	C-15
VV3D6746T12	C-100
VV3D6846R12	C-99
VV3D6846T12	C-100
VV3D7046R12	C-99
VV3D7046T12	C-100

Catalog Number	Page
VV3D7246R12	C-99
VVA25	C-13
VVA252	C-13
VVA28	C-13
VVA282N	C-13
VVA2C	C-13
VVA30	C-13
VVA302N	C-13
VVA304N	C-13
VVA34	C-13
VVA342N	C-13
VVA344	C-13
VVA344N	C-13
VVA40	C-13
VVA402N	C-13
VVA404N	C-13
VVA404NCG1	C-13
VVA442N	C-13
VVA444N	C-13
VVA462N	C-13
VVA464NCG2	C-13
VVA464NCG4	C-13
VVA482N	C-13
VVD6328T13	C-93
VVD6740R12	C-92
VVD6740T12	C-93
VVD6746R12	C-92
VVD6746T12	C-93
VVD67534T12	C-93
VVD6840R12	C-92
VVD6846R12	C-92
VVD7046R12	C-92
VVD7046T12	C-93
VVR3030	C-35
VVR4444	C-35
VVR4844	C-35
VVR4848	C-35
VVTT2828	C-68
VVTT3030	C-68
VVTT4040	C-68
VVTT4444	C-68
W2A41R4N	A-181

Alpha-Numeric Index

Catalog Number	Page
W2A444A44N	A-181
W2A444A44N90	A-181, A-182
W2A444A4N90	A-181, A-182
W2A44R4N	A-181
W2A44R4N90	A-181, A-182
W2A454A44N	A-181
W2A486A44N	A-181
W2A486A44N45	A-181, A-182
W2A486A44N90	A-181, A-182
W2A48A44N90	A-181, A-182
W2A54R44N90	A-181, A-182
W2A54R4N	A-181
W3A444A44N	A-183
W3A54R66N	A-183
WA14A2N	A-184
WA15A2N	A-184
WA18A2N	A-184
WA20A4N90	A-185
WA25R2N	A-179
WA28R2N	A-179
WA30R2N	A-179
WA30R4N	A-179
WA341R2N	A-179
WA341R4N	A-179
WA361R2N	A-179
WA361R4N	A-179
WA41R2N	A-179
WA41R2N90	A-180
WA41R4N	A-179
WA444A44N	A-179
WA444A4N	A-179
WA44R2N	A-179
WA44R2N90	A-180
WA44R34N90	A-180
WA44R4N	A-179
WA454A4N	A-179
WA486A4N	A-179
WA54R44N90	A-180
WAS14A-2N	A-186
WAS15A-2N	A-186
WAS15A-34N	A-186
WAS16A-2N	A-186

Catalog Number	Page
WAS16A34N	A-186
WAS17A-2N	A-186
WAS17A-34N	A-186
WAS18A-2N	A-186
WAS18A-34N	A-186
WAS18A44N	A-186
WAS19A-2N	A-186
WAS19A-34N	A-186
WAS19A-44N	A-186
WAS20A-2N	A-186
WAS20A-34N	A-186
WAS20A-44N	A-186
WAS21A34N	A-186
WAS22A34N	A-186
WAS22A-44N	A-186
WASC15A2N	A-187
WASC16A34N	A-187
WASC17A2N	A-187
WASC17A34N	A-187
WASC18A2N	A-187
WASC18A34N	A-187
WASC19A34N	A-187
WASC19A44N	A-187
WASC20A2N	A-187
WASC20A34N	A-187
WASC20A44N	A-187
WASC21A34N	A-187
WASC21A44N	A-187
WASC22A34N	A-187
WASC22A44N	A-187
WASC24A44N	A-187
WASC24A66N	A-187
WAT20A18A20	A-244
WCB83ACG6	A-261
WG19A	A-262
WG86A	A-262
WHRH15A3CH	A-225
WHRH17A3CH	A-225
WHRH18A3CH	A-225
WHRH18A5CH	A-225
WHRH19A3CH	A-225
WHRH19A5CH	A-225

Catalog Number	Page
WHRH20A3CH	A-225
WHRH20A5CH	A-225
WHRH21A3CH	A-225
WHRH21A5CH	A-225
WHRH21A7CH	A-225
WHRH22A3CH	A-225
WHRH22A5CH	A-225
WHRH22A7CH	A-225
WHRH24A3CH	A-225
WHRH24A5CH	A-225
WHRH24A7CH	A-225
WHRH86A5CH	A-225
WHRH86A7CH	A-225
WLB15A	A-257
WLB16A	A-257
WLB17A	A-257
WLB18A	A-257
WLB19A	A-257
WLB20A	A-257
WLB21A	A-257
WLB22A	A-257
WLB24A	A-257
WLB55A	A-257
WLB56A	A-257
WLB57A	A-257
WLB58A	A-257
WLB59A	A-257
WLB86A	A-257
WLB90A	A-257
WLB91A	A-257
WLB92A	A-257
WLB94A	A-257
WLB96A	A-257
WOH16A3CH	A-226
WOH17A3CH	A-226
WOH18A3CH	A-226
WOH18A5CH	A-226
WOH19A3CH	A-226
WOH19A5CH	A-226
WOH20A3CH	A-226
WOH20A5CH	A-226
WOH21A3CH	A-226

Alpha-Numeric Index

Catalog Number	Page
WOH21A5CH	A-226
WOH22A3CH	A-226
WOH22A5CH	A-226
WR24A19AL	A-213
WR92A22A	A-213
WRLB24A18A	A-214
WRLB86A22A	A-214
WS14A	A-211
WS15A	A-211
WS16A	A-211
WS17A	A-211
WS18A	A-211
WS19A	A-211
WS20A	A-211
WS21A	A-211
WS22A	A-211
WS24A	A-211
WS59A	A-211
WS86A	A-211
WS90A	A-211
WS91A	A-211
WS92A	A-211
WS94A	A-211
WS96A	A-211
WSLB15A	A-212
WSLB16A	A-212
WSLB17A	A-212
WSLB18A	A-212
WSLB19A	A-212
WSLB20A	A-212
WSLB21A	A-212
WSLB22A	A-212
WSLB24A	A-212
WSLB58A	A-212
WSLB90A	A-212
WSLB92A	A-212
WSLB94A	A-212
WSLB96A	A-212
WSNS22A47AS7HQ	A-218
WSNS22A496AS7HQ	A-218
WSNS86A47AS7	A-218
WSNS86A496AS7HQ	A-218

Catalog Number	Page
WSNT86A496AS7	A-238
WT18A15A	A-237
WT18A18A	A-237
WT19A15A	A-237
WT19A19A	A-237
WT20A15A	A-237
WT20A18A	A-237
WT20A19A	A-237
WT20A20A	A-237
WT21A15A	A-237
WT21A21A	A-237
WT22A15A	A-237
WT22A19A	A-237
WT22A20A	A-237
WT22A22A	A-237
WT23A20A	A-237
WT23A23A	A-237
WT24A18A	A-237
WT24A19A	A-237
WT24A24A	A-237
WT83A22A	A-237
WVH15A3	A-227
WVH16A3	A-227
WVH17A3	A-227
WVH18A3	A-227
WVH18A5	A-227
WVH19A3	A-227
WVH19A5	A-227
WVH20A3	A-227
WVH20A5	A-227
WVH21A3	A-227
WVH21A5	A-227
WVH22A3	A-227
WVH22A5	A-227
WVH24A3	A-227
WVH24A5	A-227
WVH86A3	A-227
WXA15A2N	A-188
WXA15A2NR90	A-188, A-190
WXA17A2N	A-188
WXA17A34N	A-188
WXA17A4N	A-188

Catalog Number	Page
WXA18A34N	A-188
WXA18A44N	A-188
WXA18A4N	A-188
WXA19A34N	A-188
WXA19A44N	A-188
WXA20A34N	A-188
WXA20A44N	A-188
WXA20A44NR90	A-188, A-190
WXA20A4N	A-188
WXA21A34NR90	A-188, A-190
WXA21A44N	A-188
WXA21A44NR90	A-188, A-190
WXA21A4N	A-188
WXA22A34N	A-188
WXA22A44N	A-188
WXA22A44NR90	A-188, A-190
WXA22A4N	A-189
WXA22A4NR90	A-189, A-190
WXA23A4N	A-189
WXA24A34NR90	A-189, A-190
WXA24A44NR90	A-189, A-190
WXA24A4N	A-189
WXA86A44N	A-189
WXA86A66N	A-189
WXA92A44N	A-189
WXA92A44NR90	A-189, A-190
WXA92A4N	A-189
WXA92A66N	A-189
WXA92A66NR90	A-189, A-190
WXA96A44N	A-189
WXD6718AT12	A-252
WXD6819AR12	A-251
WXHP18A3	A-216, A-228
WXHP19A5	A-216, A-228
WXHP20A5	A-216, A-228
WXHP22A5	A-216, A-228
WXHP24A5	A-216, A-228
WXHP86A5	A-216, A-228
WXOA20A44NR90	A-191
WXOA21A44NR90	A-191
WXOA22A44NR90	A-191
WXOA24A44NR90	A-191

Alpha-Numeric Index

Catalog Number	Page
WXOA92A44NR90	A-191
WXP18A18A	A-215
WXP19A19A	A-215
WXP20A20A	A-215
WXP21A21A	A-215
WXP22A22A	A-215
WXP24A24A	A-215
WXP92A92A	A-215
WXP94A94A	A-215
XA132N	C-17
XA142N	C-17
XA144N	C-17
XA152N	C-17
XA154N	C-17
XA15A2N	A-16
XA15A34NR90	A-18
XA15A44NR90	A-18
XA15A4N	A-16
XA162N	C-17
XA164N	C-17
XA16A2N	A-16
XA16A4N	A-16
XA172N	C-17
XA174N	C-17
XA17A2N	A-16
XA17A34N	A-16
XA17A34NR90	A-18
XA17A4N	A-16
XA184N	C-17
XA18A2N	A-16
XA18A34N	A-16
XA18A34NR90	A-18
XA18A44NR90	A-18
XA18A4N	A-16
XA194N	C-17
XA19A2N	A-16
XA19A34N	A-16
XA19A34NR90	A-18
XA19A44N	A-16
XA19A44NR90	A-18
XA19A4N	A-16
XA204N	C-17

Catalog Number	Page
XA20A2N	A-16
XA20A44N	A-16
XA20A44NR90	A-18
XA20A4N	A-16
XA20A4N90	A-18
XA214N	C-17
XA21A44N	A-16
XA21A44NR90	A-18
XA21A4N	A-16
XA224N	C-17
XA22A44N	A-17
XA22A4N	A-17
XA22A4N90	A-18
XA22A66N	A-17
XA24A44N	A-17
XA24A44NR90	A-18
XA24A4N	A-17
XA574N	C-17
XA594N	C-17
XA59A44N	A-17
XA59A4N	A-17
XA91A4N	A-17
XA92A44N	A-17
XA92A4N	A-17
XA96A4NGS	A-17
XA96A66NGS	A-17
XAL17A4N	A-19
XAL19A4N	A-19
XD6515T14	C-104
XD65515AT12	A-122
XD65517R12	C-106
XD65517T12	C-104
XD6714R12	C-106
XD6714R14	C-106
XD6714T12	C-104
XD6714T14	C-104
XD6715AR12	A-123
XD6715R12	C-106
XD6715T12	C-104
XD6716AT12	A-122
XD6716R12	C-106
XD6716T12	C-104

Catalog Number	Page
XD6717AR12	A-123
XD6717AT12	A-122
XD6717T12	C-104
XD6718AR12	A-123
XD6718AT12	A-122
XD6718R12	C-106
XD6718T12	C-104
XD6719R12	C-106
XD6720AT12	A-122
XD6722AR12GS	A-123
XD67520T12	C-104
XD6816T12	C-104
XD6817AR12	A-123
XD6817AT12	A-122
XD6818AR12	A-123
XD6818R12	C-106
XD6819T12	C-106
XD6823AR12	A-123
XD6859AT12	A-122
XD7022AR12	A-123
XDL6715T12	C-105
XDL6717R12	C-107
XHP16A3	A-50, A-73
XHP16A5	A-50, A-73
XHP17A3	A-50, A-73
XHP17A5	A-50, A-73
XHP18A3	A-50, A-73
XHP193	C-39, C-54
XHP19A3	A-50, A-73
XHP19A5	A-50
XHP20A3	A-50, A-73
XHP20A5	A-50, A-73
XHP21A5	A-50
XHP22A3	A-50, A-73
XHP22A5	A-50, A-73
XHP24A3	A-50, A-73
XHP24A5	A-50, A-73
XHP573HQ	C-39, C-54
XHP86A5	A-50, A-73
XHP90A5	A-50, A-73
XHP92A3	A-50, A-73
XHP92A5	A-50, A-73

Alpha-Numeric Index

Catalog Number	Page
XP1313	C-37
XP1414	C-37
XP1515	C-37
XP1616	C-37
XP1717	C-37
XP17A17A	A-48
XP1818	C-37
XP18A18A	A-48
XP1919	C-37
XP1919HC	C-37
XP19A19A	A-48
XP2020	C-37
XP20A20A	A-48
XP2121	C-37
XP2222	C-37
XP22A22A	A-48
XP24A24A	A-48
XP5656	C-37
XP59A59A	A-48
XP90A90A	A-48
XPL1515	C-38
XPL16A16A	A-49
XPL1717	C-38
XPL17A17A	A-49
XPL20A20A	A-49
XPL56A56A	A-49
XPL57A57A	A-49
XPL59A59A	A-49
XT15A15A	A-95
XT17A17A	A-95
XT18A18A	A-95
XT20A20A	A-95
XT22A22A	A-95
XT23A23A	A-95
XTL1717	C-77
YNA32R	A-208
YNA32R4N	A-208
YNA34R	A-208
YNA36R	A-208
YNA39R	A-208
YNA43R	A-208
YNA451R	A-208

Catalog Number	Page
YNA49R	A-208





www.burndy.com | 1-800-346-4175

Customer Service Department

7 Aviation Park Drive
Londonderry, NH 03053
1-800-346-4175
1-603-647-5299 (International)

Canada

1-800-361-6975 (Quebec)
1-800-387-6487 (All other provinces)

Mexico

011-52-722-265-4400

Brazil

011-55-11-5515-7225

Tool Service Center

Littleton Industrial Park
Littleton, NH 03561
1-800-426-8720

 **BURNDY**

