

Catalog Number	Accommodates			Dimensions			Color Code Die Index
	Copper Conductor Class B,C (mm <sup>2</sup> )	Metric class 2 mm <sup>2</sup>	Navy	Outside Diameter (OD)	Overall Length (L)	Barrel Length (B)	
YS8C	8 AWG (8.37) 8 AWG Class G,H,I,K,M 6 AWG Str/Sol (13.3)	10	23	.27 [7]	1.75 [44]	.78 [20]	RED 49
YS6C	6 AWG STR/SOL (13.3)	--	--	.29 [7]	2.38 [60]	1.09 [28]	BLUE 7 OR 374
YS5C	5 AWG (18.8)	--	30	.30 [8]	2.55 [65]	1.09 [28]	BLUE 7 OR 374
YS4C	4 AWG (21.2)	--	40	.34 [9]	2.55 [65]	1.09 [28]	GRAY 8 OR 346
YS3C	3 AWG (26.7)	25	50	.38 [10]	2.80 [71]	1.22 [31]	WHITE 9
YS2C	2 AWG (33.6)	35	60	.42 [11]	2.82 [71]	1.22 [31]	BROWN 10
YS1C	1 AWG (42.4)	50	75	.46 [12]	3.07 [78]	1.34 [34]	GREEN 11 OR 375
YS25	1/0 AWG (53.5)	--	100	.51 [13]	3.08 [78]	1.34 [34]	PINK 12 OR 348
YS26	2/0 AWG (67.2)	70	125	.56 [14]	3.30 [84]	1.45 [37]	BLACK 13
YS27	3/0 AWG (85)	--	150	.62 [16]	3.30 [84]	1.45 [37]	ORANGE 14
YS28	4/0 AWG (107)	--	200	.69 [18]	3.57 [91]	1.58 [40]	PURPLE 15
YS29	250 kcmil (127)	--	250	.75 [19]	3.58 [91]	1.58 [40]	YELLOW 16
YS30	300 kcmil (152)	150	300	.81 [21]	4.34 [110]	1.95 [50]	WHITE 17 OR 298
YS31	350 kcmil (177)	185	350	.88 [22]	4.35 [110]	1.95 [50]	RED 18 OR 324
YS32	400 kcmil (203)	--	400	.95 [24]	4.62 [117]	2.08 [53]	BLUE 19 OR 470

Catalog Number	Accommodates			Dimensions			Color Code Die Index
	Copper Conductor Class B,C (mm <sup>2</sup> )	Metric class 2 mm <sup>2</sup>	Navy	Outside Diameter (OD)	Overall Length (L)	Barrel Length (B)	
YS33	450 kcmil (228)	--	--	1.01 [26]	4.63 [118]	2.08 [53]	GRAY 326 OR 538
YS34	500 kcmil (253)	240	--	1.06 [27]	4.91 [125]	2.20 [56]	BROWN 20 OR 299
YS35	550 kcmil (278)	--	500	1.13 [29]	5.71 [145]	2.56 [65]	YELLOW 21
YS36	600 kcmil (304)	300	--	1.18 [30]	5.85 [149]	2.63 [67]	GREEN 22 OR 472
YS37	650 kcmil (329)	--	650	1.23 [31]	6.10 [156]	2.75 [70]	ORANGE 23
YS38	700 kcmil (355)	--	--	1.25 [32]	6.24 [158]	2.75 [70]	PINK 400
YS39	750 kcmil (380)	--	--	1.30 [33]	6.38 [162]	2.81 [71]	BLACK 24
YS40	800 kcmil (405)	400	--	1.35 [34]	6.39 [162]	2.88 [73]	ORANGE 25
YS41	850 kcmil (430)	--	800	1.38 [35]	6.53 [166]	2.88 [73]	GOLD 26
YS44	1000 kcmil (507)	500	--	1.49 [38]	6.55 [167]	2.94 [75]	WHITE 27
YS45	1250 kcmil (633)	--	--	1.69 [43]	6.97 [177]	3.13 [80]	YELLOW 29
YS453	1300 kcmil (700)	--	1300	1.74 [44]	6.98 [177]	3.13 [80]	ORANGE 30
YS46	1500 kcmil (760)	--	--	1.84 [47]	7.01 [178]	3.13 [80]	GREEN 31
YS47	1750 kcmil (887)	--	--	1.98 [50]	7.33 [186]	3.38 [86]	GRAY 33
YS48	2000 kcmil (1010)	1013	--	2.13 [54]	7.57 [192]	3.27 [83]	BROWN 34
YS486	2500 kcmil (1215)	--	--	2.38 [60]	8.10 [206]	3.63 [92]	--

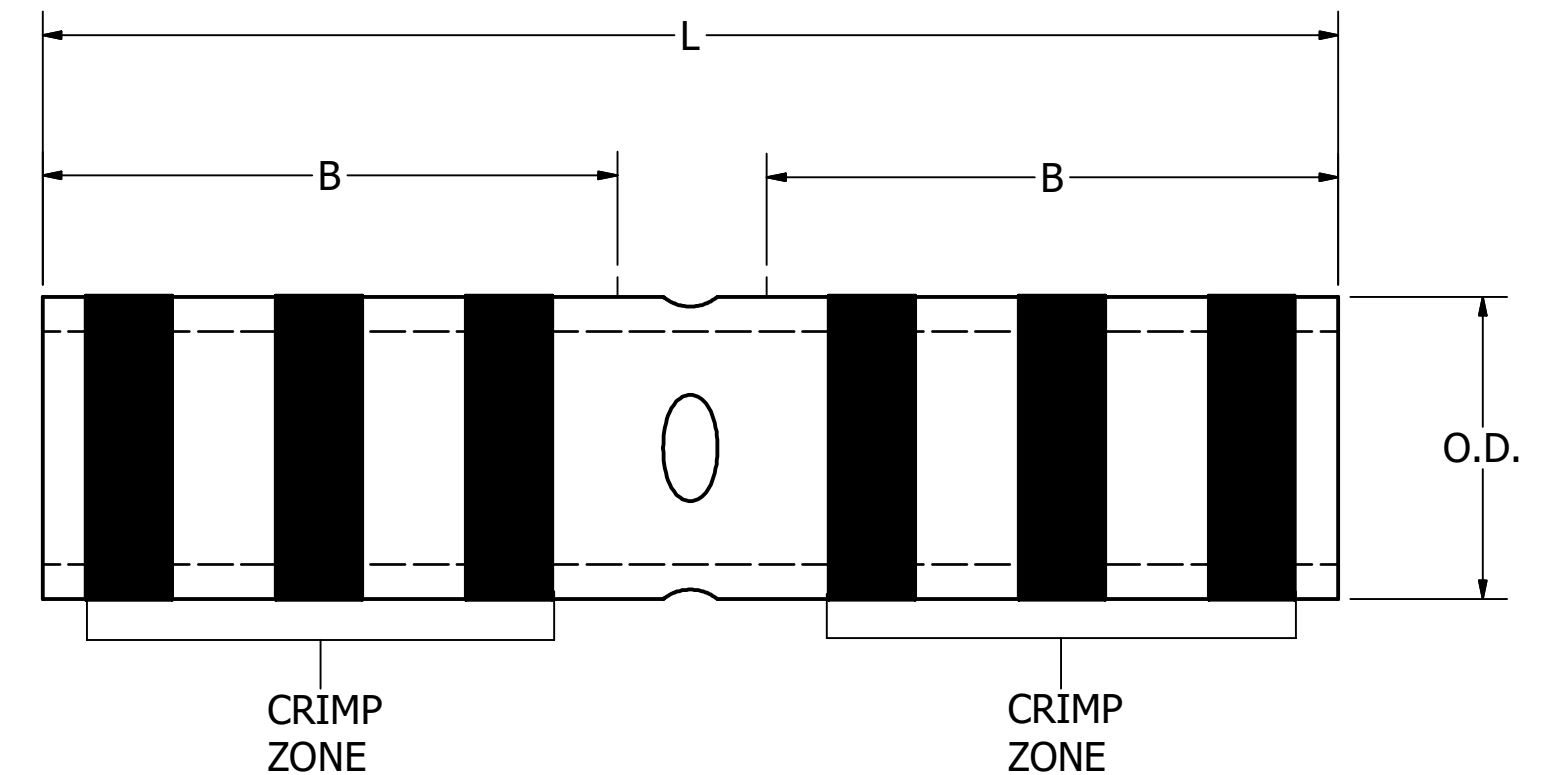
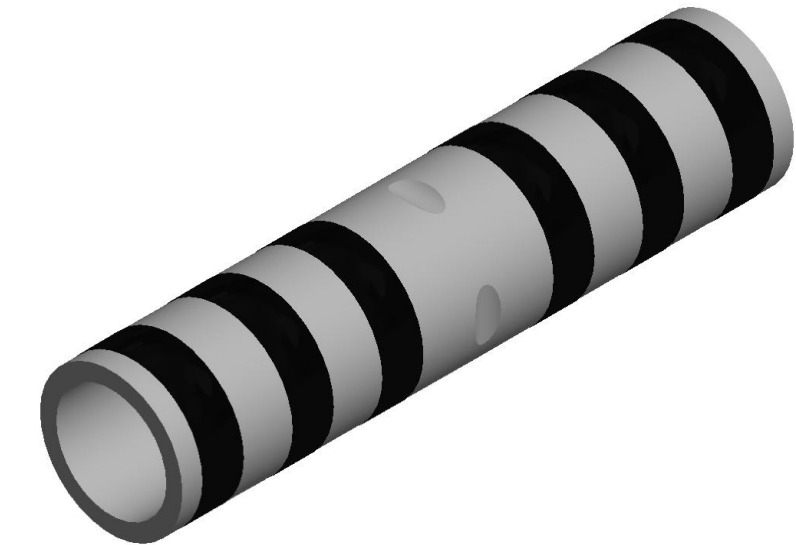

**NOTES:**

- CONNECTOR: TIN PLATED COPPER COMPRESSION SPLICE.
- CONNECTION: COMPRESSION CONNECTIONS MADE ARE IRREVERSIBLE AND MAINTENANCE FREE.
- APPLICABLE STANDARDS: CONNECTORS ARE ONLY UL LISTED AND CSA CERTIFIED WHEN INSTALLED WITH THE BURNDY ENGINEERED SYSTEM AND SELECT OTHER CRIMP TOOL MANUFACTURERS IN ACCORDANCE WITH ONE OR MORE UL CATEGORIES.
  - UL LISTED AND CSA CERTIFIED WIRE CONNECTORS PER UL 486A-486B, CSA 22.2 NO. 65.
- TEMPERATURE AND VOLTAGE RATING: 90°C UP TO 35kV.
- WIRE ACCOMMODATE TYPES (SEE TABLE):
  - COPPER CONDUCTOR: SOLID, CLASS B (CONCENTRIC, COMPRESS, COMPACT) OR CLASS C STRANDING.
- CONNECTOR FINISHES AND SUFFIX: SEE SECTION C OF THE BURNDY MASTER CATALOG FOR PLATING SERVICE TEMPERATURE RATINGS. A. NICKEL PLATED: APPLY SUFFIX "NK" TO A CATALOG NUMBER IN THE TABLE. B. SILVER PLATED: APPLY "SV" TO A CATALOG NUMBER IN THE TABLE. C. TIN ZINC: APPLY "TZ" TO A CATALOG NUMBER IN THE TABLE. D. BARE CONNECTOR: APPLY "BR" TO A CATALOG NUMBER MEANS NO PLATING.
- FEATURES:
  - TYPICAL INK BARREL MARKING COLOR CODE (AS SPACE PERMITS): CRIMP ZONE IS INDICATED BY COLOR BANDS, BURNDY CORPORATE NAME OR LOGO, UL LOGO (IF APPLICABLE), CSA LOGO (IF APPLICABLE), WIRE SIZE, DIE COLOR CODE, DIE INDEX NUMBER.
  - TYPICAL METAL STAMP MARKINGS (AS SPACE PERMITS): CRIMP ZONE IS INDICATED BY METAL KNURL BANDS, BURNDY CORPORATE NAME OR LOGO, UL LOGO (IF APPLICABLE), CSA LOGO (IF APPLICABLE), WIRE SIZE, DIE COLOR CODE, DIE INDEX NUMBER, AND INCLUDES AN INK COLOR CODE DOT MARKING.
  - BARREL DESIGN: BARREL END AT THE WIRE HAS AN INTERNAL CHAMFER, ALLOWING FOR A SMOOTH WIRE INSERTION.
  - BARREL IS DESIGNED WITH INDENT CABLE STOPS IN THE CENTER OF THE BARREL.
- INSTALLATION TOOLING AND DIES ARE CONSTANTLY BEING UPDATED. PLEASE SEE BURNDY MASTER CATALOG FOR THIS PRODUCT FAMILY, WHICH CAN BE FOUND ON THE BURNDY WEBSITE.
- YS486 IS NOT UL LISTED OR CSA CERTIFIED.

TO ORDER BURNDY® PRODUCTS CALL		LONG BARREL CODE SPLICES	
UNITED STATES 1-800-346-4175 (LONDONDERRY, NH)		ITEM NO: SEE TABLE	
CANADA: 1-800-361-6975 (QUEBEC) 1-800-387-6487 (ALL OTHER PROVINCES)		CAT. NO: SEE TABLE	
FOR PRODUCT INFO: <a href="http://www.burndy.com">http://www.burndy.com</a>		DRAWN BY: M.P. 08/24/1993	
		CHECKER: R.ROBICHEAU 07/01/1993	
		DSN APRVL: C.PALAGI 07/06/1993	
		MFG APRVL: --	
		QA APRVL: --	
		MKT APRVL: --	
		PROD FAM: C&I COMPRESSION	
		DRAWING NO	
		SD007774-01	
		REV	
		M	
		SHEET 1 OF 5	

CATALOG NUMBER DESIGNATION	WIRE SIZE ACCOMMODATES		Hydraulic Tools - Dies Required (# Crimps)					Hydraulic Tools - Dieless		Wire Strip Length
	Class B, C Conductor (CU Only)	Color Code and Die Index Number	MD6, 600, 500 Series	750, 35 Series	45 Series Use PT6515 with U Dies	46 Series Use PUADP1 with U Dies	60 Series	81K 4PC Series	644 444 Series	
YS8C	8 AWG 6 AWG Sol	RED 49	X8CRT (2) W8CRT (2) W8CVT (2)	U8CRT (2)	U8CRT (2)	U8CRT (2)	--	1 CRIMP	--	7/8
YS6C	6 AWG Str Sol	BLUE 7	X5CRT (2) W5CRT (2) W5CVT (2)	U5CRT (2)	U5CRT (2)	U5CRT (2)	--	1 CRIMP	--	1-3/16
YS5C	5 AWG	BLUE 7	X5CRT (2) W5CRT (2) W5CVT (2)	U5CRT (2)	U5CRT (2)	U5CRT (2)	--	1 CRIMP	--	1-3/16
YS4C	4 AWG	GRAY 8	X4CRT (2) W4CRT (2) W4CVT (2)	U4CRT (2)	U4CRT (2)	U4CRT (2)	--	1 CRIMP	1 CRIMP	1-3/16
YS3C	3 Str 2 Sol	WHITE 9	W3CRT (2)	U3CRT (2)	U3CRT (2)	U3CRT (2)	--	2 OVERLAPPING CRIMPS	1 CRIMP	1-5/16
YS2C	2 AWG	BROWN 10	X2CRT (2) W2CRT (2) W2CVT (2)	U2CRT (2)	U2CRT (2)	U2CRT (2)	--	2 OVERLAPPING CRIMPS	1 CRIMP	1-5/16
YS1C	1 AWG	GREEN 11	X1CRT1 (2) W1CRT1 (2) W1CVT (2)	U1CRT1 (2)	U1CRT1 (2)	U1CRT1 (2)	--	2 OVERLAPPING CRIMPS	1 CRIMP	1-7/16
YS25	1/0 AWG	PINK 12	X25RT (4) W25RT (4) W25VT (4)	U25RT (2)	U25RT (2)	U25RT (2)	--	2 OVERLAPPING CRIMPS	1 CRIMP	1-7/16
YS26	2/0 AWG	BLACK 13	X26RT (4) W26RT (4) W26VT (4)	U26RT (2)	U26RT (2)	U26RT (2)	--	2 CRIMPS	1 CRIMP	1-1/2
YS27	3/0 AWG	ORANGE 14	X27RT (6) W27RT (4) W27VT (4)	U27RT (2)	U27RT (2)	U27RT (2)	--	2 CRIMPS	1 CRIMP	1-1/2
YS28	4/0 AWG	PURPLE 15	X28RT (6) W28RT (4) W28VT (4)	U28RT (2)	U28RT (2)	U28RT (2)	L28RT (1)	2 CRIMPS	1 CRIMP	1-11/16
YS29	250 kcmil	YELLOW 16	X29RT (8) W29RT (4) W29VT (4)	U29RT (2)	U29RT (2)	U29RT (2)	L29RT (1)	2 CRIMPS	1 CRIMP	1-11/16
YS30	300 kcmil	WHITE 17	W30RT (4)* W30VT (4)	U30RT (4)	U30RT (4)	U30RT (4)	L30RT (1)	3 OVERLAPPING CRIMPS	1 CRIMP	2-1/16
YS31	350 kcmil	RED 18	W31RT (4)* W31VT (4)	U31RT (4)	U31RT (4)	U31RT (4)	L31RT (1)	3 OVERLAPPING CRIMPS	1 CRIMP	2-1/16
YS32	400 kcmil	BLUE 19	W32RT (4)* W32VT (4)	U32RT (4)	U32RT (4)	U32RT (4)	L32RT (1)	3 OVERLAPPING CRIMPS	1 CRIMP	2-1/16

REV	DATE	DESCRIPTION	ECO	BY	C'H'K.
M	10/01/2021	UPDATED AS PER MARKUP	211007013128	YR	WP

TO ORDER BURNDY® PRODUCTS CALL		LONG BARREL CODE SPLICES	
UNITED STATES 1-800-346-4175 (LONDONDERRY, NH)		ITEM NO: SEE TABLE	
CANADA: 1-800-361-6975 (QUEBEC) 1-800-387-6487 (ALL OTHER PROVINCES)		CAT. NO: SEE TABLE	
FOR PRODUCT INFO: <a href="http://www.burndy.com">http://www.burndy.com</a>		DRAWN BY: M.P. 08/24/1993	
		CHECKER: R.ROBICHEAU 07/01/1993	
		DSN APRVL: C.PALAGI 07/06/1993	
		MFG APRVL: --	
		QA APRVL: --	
		MKT APRVL: --	
PROD FAM: C&I COMPRESSION	DRAWING NO	REV	
PROJECT #: --	SIZE	SD007774-01	M
DOCUMENT TYPE: SALES	C	SHEET 2 OF 5	
REL LEVEL: Released			

CATALOG NUMBER DESIGNATION	WIRE SIZE ACCOMMODATES	Color Code and Die Index Number	Hydraulic Tools - Dies Required (# Crimps)					Hydraulic Tools - Dieless		Wire Strip Length
	Class B, C Conductor (CU Only)		MD6, 600, 500 Series	750, 35 Series	45 Series Use PT6515 with U Dies	46 Series Use PUADP1 with U Dies	60 Series	81K 4PC Series	644 444 Series	
YS33	450 kcmil	GRAY 326	W33RT (4)* W33VT (4)	U33RT (4)	U33RT (4)	U33RT (4)	L33RT (1)	4 OVERLAPPING CRIMPS	1 CRIMP	2-3/16
YS34	500 kcmil	BROWN 20	W34RT (4)* W34VT (4)	U34RT (4)	U34RT (4)	U34RT (4)	L34RT (2)	4 OVERLAPPING CRIMPS	1 CRIMP	2-1/4
YS35	550 kcmil	YELLOW 21	--	U35RT (4)	U35RT (4)	U35RT (4)	L35RT (2)	4 OVERLAPPING CRIMPS	1 CRIMP	2-5/8
YS36	600 kcmil	GREEN 22	--	U36RT (4)	U36RT (4)	U36RT (4)	L36RT (2)	4 CRIMPS	1 CRIMP	2-11/16
YS37	650 kcmil	ORANGE 23	--	U37RT (4)	U37RT (4)	U37RT (4)	L37RT (2)	4 CRIMPS	1 CRIMP	2-13/16
YS38	700 kcmil	PINK 400	--	U38RT (4)	U38RT (4)	U38RT (4)	L38RT (2)	4 CRIMPS	1 CRIMP	2-13/16
YS39	750 kcmil	BLACK 24	--	U39RT (4)	U39RT (4)	U39RT (4) P39RT (4)	L39RT (2)	4 CRIMPS	1 CRIMP	2-7/8
YS40	800 kcmil	ORANGE 25	--	--	S40RT (4)	P40RT (4)	L40RT (2)	4 CRIMPS	1 CRIMP	3
YS41	850 kcmil	GOLD 26	--	--	--	P41D with P44PR (2)	--	4 CRIMPS	1 CRIMP	3
YS44	1000 kcmil	WHITE 27	--	--	S44RT (4)	P44RT (4)	L44RT (2)	4 CRIMPS	1 CRIMP	3
YS45	1250 kcmil	YELLOW 29	--	--	S45RT (6)	P45RT (6)	L45RT (6)	--	--	3-3/16
YS453	1300 kcmil	ORANGE 30	--	--	--	--	--	--	--	3-3/16
YS46	1500 kcmil	GREEN 31	--	--	S46RT (6)	P46RT (6)	L46RT (3)	--	--	3-3/16
YS47	1750 kcmil	GRAY 33	--	--	--	--	L47RT (3)	--	--	3-7/16
YS48	2000 kcmil	BROWN 34	--	--	--	--	L48RT (4)	--	--	3-3/8
YS486	--	--	--	--	--	--	--	--	--	3-11/16

REV	DATE	DESCRIPTION	ECO	BY	C'H'K.
M	10/01/2021	UPDATED AS PER MARKUP	211007013128	YR	WP

TO ORDER BURNDY® PRODUCTS CALL		LONG BARREL CODE SPLICES	
UNITED STATES 1-800-346-4175 (LONDONDERRY, NH)		ITEM NO: SEE TABLE	
CANADA: 1-800-361-6975 (QUEBEC) 1-800-387-6487 (ALL OTHER PROVINCES)		CAT. NO: SEE TABLE	
FOR PRODUCT INFO: <a href="http://www.burndy.com">http://www.burndy.com</a>		DRAWN BY: M.P. 08/24/1993	
	CHECKER: R.ROBICHEAU 07/01/1993	DSN APRVL: C.PALAGI 07/06/1993	
	MFG APRVL: --	QA APRVL: --	
	MKT APRVL: --	PROD FAM: C&I COMPRESSION	
		PROJECT #: --	
		DOCUMENT TYPE: SALES	DRAWING NO
		REL LEVEL: Released	SD007774-01
			REV
			M
			SHEET 3 OF 5

CATALOG NUMBER DESIGNATION	WIRE SIZE ACCOMMODATES	Color Code and Die Index Number	Mechanical & Ratchet Dies Required (# Crimps)		Mechanical & Ratchet Dedicated Die Tools # Crimps				Wire Strip Length
	Class B, C Conductor (CU Only)		MD6 and MD7 Series *Due to handle force not recommended	OUR840 *Due to handle force not recommended	MY293 MY2911	MRC840	Y122CMR	Y1MRTC	
YS8C	#8 AWG	RED 49	X8CRT (2) W8CRT (2) W8CVT (2)	X8CRT (2) W8CRT (2) W8CVT (2)	2 CRIMPS	2 CRIMPS	2 CRIMPS	2 CRIMPS	7/8
YS6C	#6 AWG Str Sol	BLUE 7	X5CRT (2) W5CRT (2) W5CVT (2)	X5CRT (2) W5CRT (2) W5CVT (2)	2 CRIMPS	2 CRIMPS	2 CRIMPS	2 CRIMPS	1-3/16
YS5C	#5 AWG	BLUE 7	X5CRT (2) W5CRT (2) W5CVT (2)	X5CRT (2) W5CRT (2) W5CVT (2)	2 CRIMPS	2 CRIMPS	2 CRIMPS	2 CRIMPS	1-3/16
YS4C	#4 AWG	GRAY 8	X4CRT (2) W4CRT (2) W4CVT (2)	X4CRT (2) W4CRT (2) W4CVT (2)	2 CRIMPS	2 CRIMPS	4 CRIMPS	4 CRIMPS	1-3/16
YS3C	#3 Str #2 Sol	WHITE 9	W3CRT (2)	W3CRT (2)	2 CRIMPS	2 CRIMPS	4 CRIMPS	4 CRIMPS	1-5/16
YS2C	#2 AWG	BROWN 10	X2CRT (2) W2CRT (2) W2CVT (2)	X2CRT (2) W2CRT (2) W2CVT (2)	2 CRIMPS	2 CRIMPS	4 CRIMPS	4 CRIMPS	1-5/16
YS1C	#1 AWG	GREEN 11	X1CRT1 (2) W1CRT1 (2) W1CVT (2)	X1CRT1 (2) W1CRT1 (2) W1CVT (2)	2 CRIMPS	2 CRIMPS	--	4 CRIMPS	1-7/16
YS25	1/0 AWG	PINK 12	X25RT (4) W25RT (4) W25VT (4)	X25RT (4) W25RT (4)* W25VT (4)*	2 CRIMPS	4 CRIMPS	--	--	1-7/16
YS26	2/0 AWG	BLACK 13	X26RT (4) W26RT (4) W26VT (4)	X26RT (4) W26RT (4)* W26VT (4)*	2 CRIMPS	4 CRIMPS	--	--	1-1/2
YS27	3/0 AWG	ORANGE 14	X27RT (6) W27RT (4) W27VT (4)	X27RT (6) W27RT (4)* W27VT (4)*	2 CRIMPS	4 CRIMPS	--	--	1-1/2
YS28	4/0 AWG	PURPLE 15	X28RT (6) W28RT (4) W28VT (4)	X28RT (6) W28RT (4)* W28VT (4)*	2 CRIMPS	4 CRIMPS	--	--	1-11/16
YS29	250 kcmil	YELLOW 16	X29RT (8) W29RT (4) W29VT (4)	X29RT (8) W29RT (4)* W29VT (4)*	2 CRIMPS	--	--	--	1-11/16
YS30	300 kcmil	WHITE 17	W30RT (4)* W30VT (4)	--	--	--	--	--	2-1/16
YS31	350 kcmil	RED 18	W31RT (4)* W31VT (4)	--	--	--	--	--	2-1/16
YS32	400 kcmil	BLUE 19	W32RT (4)* W32VT (4)	--	--	--	--	--	2-1/16
YS33	450 kcmil	GRAY 326	W33RT (4)* W33VT (4)	--	--	--	--	--	2-3/16
YS34	500 kcmil	BROWN 20	W34RT (4)* W34VT (4)	--	--	--	--	--	2-1/4

REV	DATE	DESCRIPTION	ECO	BY	C'H'K.
M	10/01/2021	UPDATED AS PER MARKUP	211007013128	YR	WP

TO ORDER BURNDY® PRODUCTS CALL		LONG BARREL CODE SPLICES	
UNITED STATES 1-800-346-4175 (LONDONDERRY, NH)		ITEM NO: SEE TABLE	
CANADA: 1-800-361-6975 (QUEBEC) 1-800-387-6487 (ALL OTHER PROVINCES)		CAT. NO: SEE TABLE	
FOR PRODUCT INFO: <a href="http://www.burndy.com">http://www.burndy.com</a>		DRAWN BY: M.P. 08/24/1993	
		CHECKER: R.ROBICHEAU 07/01/1993	
		DSN APRVL: C.PALAGI 07/06/1993	
		MFG APRVL: --	
		QA APRVL: --	
		MKT APRVL: --	
PROD FAM: C&I COMPRESSION	DRAWING NO	REV	
PROJECT #: --	SIZE	SD007774-01	M
DOCUMENT TYPE: SALES	C	SHEET 4 OF 5	
REL LEVEL: Released			

# Installation Instructions

1. Select the appropriate connector based on:  
Wire Material, Wire Construction, Wire Size
2. Strip the insulation to the appropriate wire strip length, based on the table's Wire Strip Length recommendation for the selected connector.
3. As a best practice, wire brush the bare conductor to remove any oxides.  
DO NOT wire brush tin-plated connectors.
4. Insert the conductor into the barrel for the full length. If the connector has an inspection window, the conductor end can easily be seen to verify full wire insertion.
5. Apply the proper number of crimps specified by the appropriate illustration.
6. \*Some catalog numbers require overlapping crimps when using the 81K or 4PC Series of installation tools. Please refer to the overlapping crimp image that is applicable based on the number of crimps required. Overlap each consecutive crimp so that the completed installation of all overlapping crimps covers the entire crimp zone.
7. Once all crimps have been completed, the connection can be easily inspected for proper installation.

## NOTES:

- Ink Marked Barrels: Illustrations show black solid bands however this is just a representation of the crimp zones. See individual connector for actual crimp band color code. Example:



## NOTES:

- Metal Stamped Marked Barrels: Illustrations show hatch knurl bands and a black solid color code dot. See individual connector for actual color dot color code.

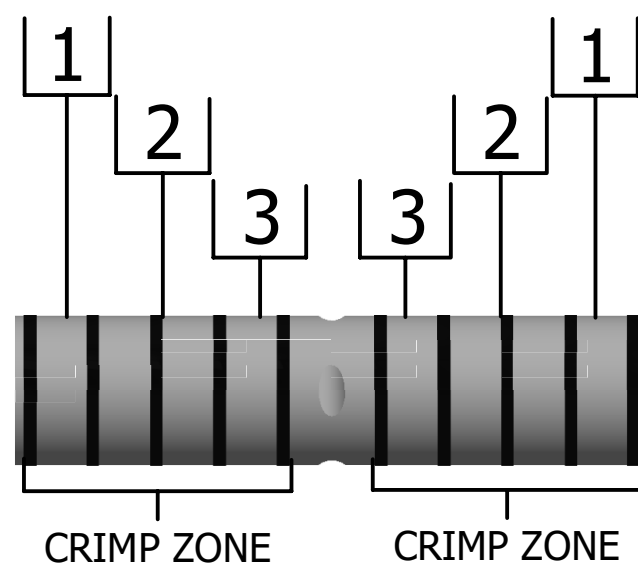

**3 OVERLAPPING**

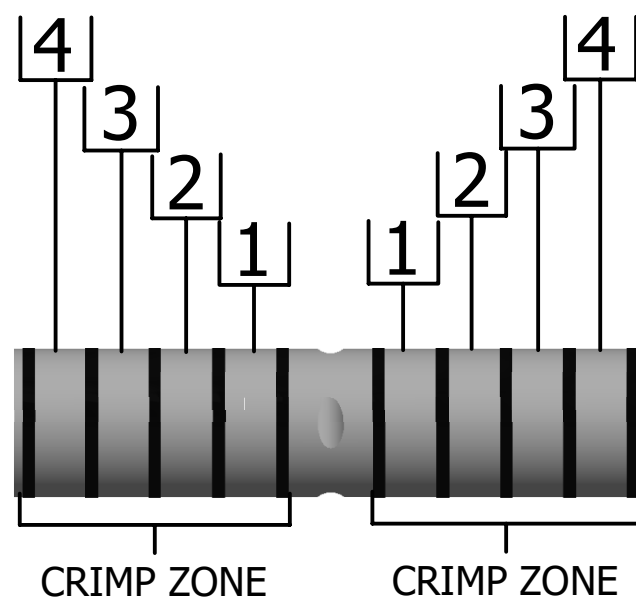

**4 OVERLAPPING**

CATALOG NUMBER DESIGNATION				
YS6C	YS4C	YS3C	YS2C	YS1C
YS25	YS26	YS27	YS28	YS29
YS40	YS41	YS44	YS48	

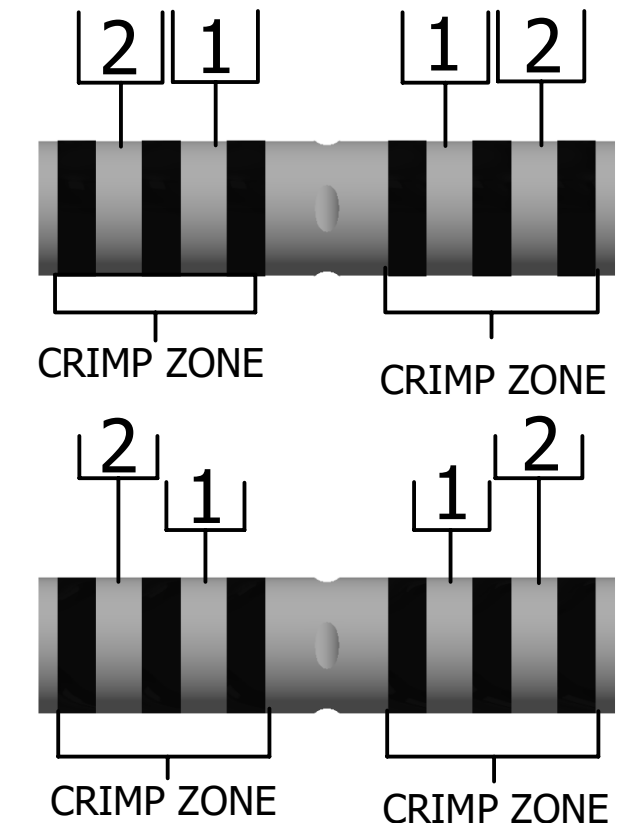
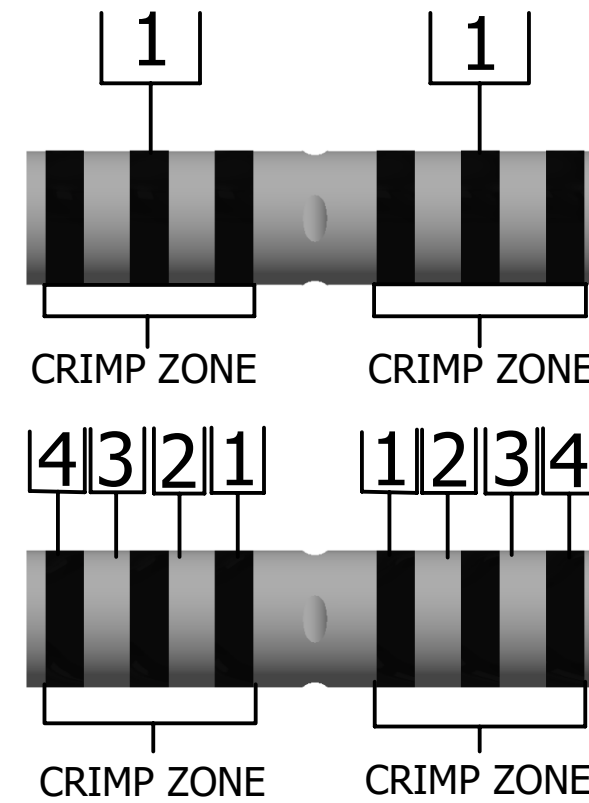

**2 OVERLAPPING**

CATALOG NUMBER DESIGNATION					
YS30	YS31	YS32	YS34	YS36	YS39

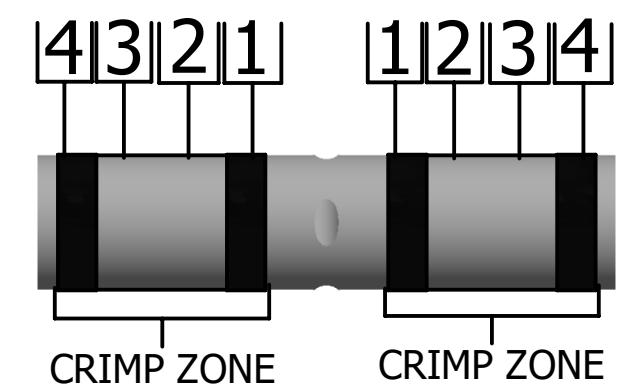
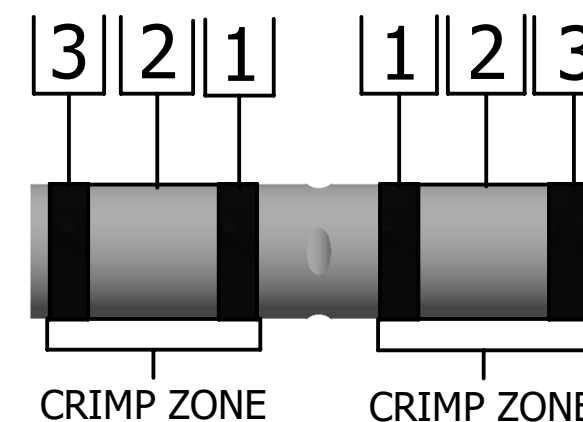
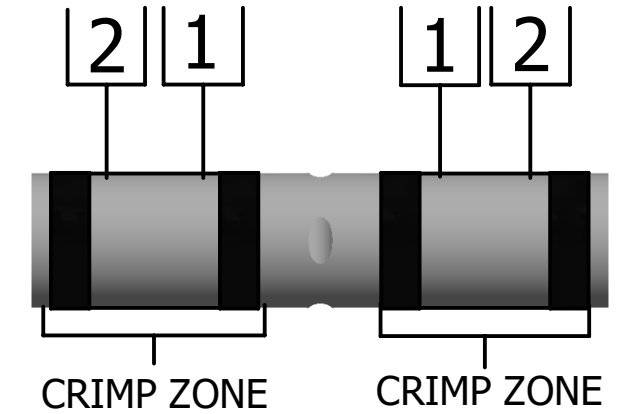
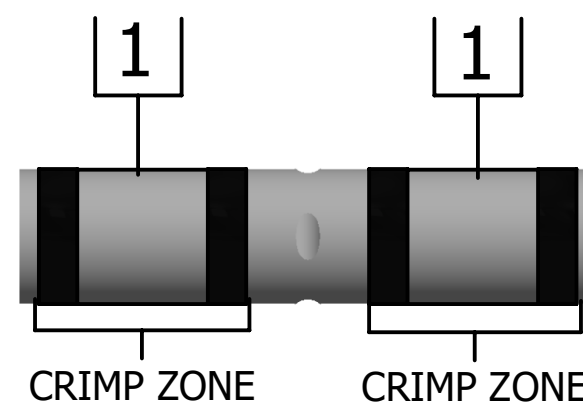

TO ORDER BURNDY® PRODUCTS CALL		LONG BARREL CODE SPLICES	
UNITED STATES 1-800-346-4175 (LONDONDERRY, NH)		ITEM NO: SEE TABLE	
CANADA: 1-800-361-6975 (QUEBEC) 1-800-387-6487 (ALL OTHER PROVINCES)		CAT. NO: SEE TABLE	
FOR PRODUCT INFO: <a href="http://www.burndy.com">http://www.burndy.com</a>		DRAWN BY: M.P. 08/24/1993	
		CHECKER: R.ROBICHEAU 07/01/1993	
		DSN APRVL: C.PALAGI 07/06/1993	
		MFG APRVL: --	
		QA APRVL: --	
		MKT APRVL: --	
		PROD FAM: C&I COMPRESSION	
		DRAWING NO	
		SD007774-01	
		REV	
		M	
		SHEET 5 OF 5	