PLATFORMS

Aluminum Platforms

Better than steel or wood platforms for mounting transformers, regulators, switches and heavy equipment.

1. Easier handling, storage and transporting.
2. Easier installation.
3. Easier adjustment.
4. Lower installed cost.
5. Maintenance free.
6. Comes assembled or non-assembled.
7. Built-in safety factors.
8. High strength 6061-T6 aluminum alloy
9. 70 standard platforms to choose from.
10. Platforms can be used for grounding.
11. Reusable.
12. Custom platforms available to meet special needs.

CMC recommended loading data contained herein should be used only by trained, skilled technical persons. The customer is cautioned that the loading data is published only for general information in platform selection and should be used only by qualified persons. Loads listed are within the aluminum associations allowable stress design method for 6061-T6 aluminum alloy.

Loading information is provided as general information to be used for preliminary selection of platforms and should be used only by qualified persons. The allowable loads are based on supported transformer loads only, and do not include location specific conditions such as Wind or Seismic loading. Installations that are subject to seismic, wind, or other unusual loading demands should be evaluated by a qualified person. Ratings for specific installations can be provided by CMC. Load ratings shown represent platform capacity only and may be limited by supporting pole and/or platform connections to the supporting pole, which should be evaluated by a qualified person. The use of extra pole kits can significantly increase the load carrying capacity of the platforms.

CMC platforms may be combined to obtain quantity prices. All aluminum parts and galvanized steel bolts, nuts and lock washers for assembling the platforms are included. Hardware for attaching the platforms to the poles is not provided. Custom additional platforms are available.

PLATFORMS ARE SHIPPED ASSEMBLED (standard). Add suffix “-UNA” to catalog number to order a NON-assembled platform.

We do not supply the wood for the walkways.

HEAVY DUTY PLATFORM

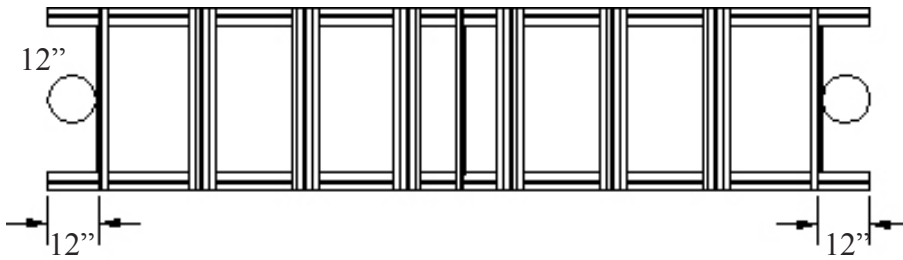

See page C-8 for Switch Fuse Assembly. We do not supply the wood for the walkways.

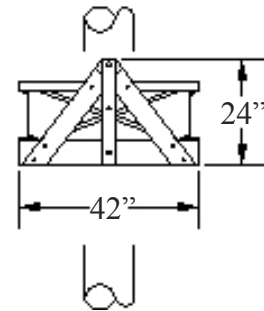
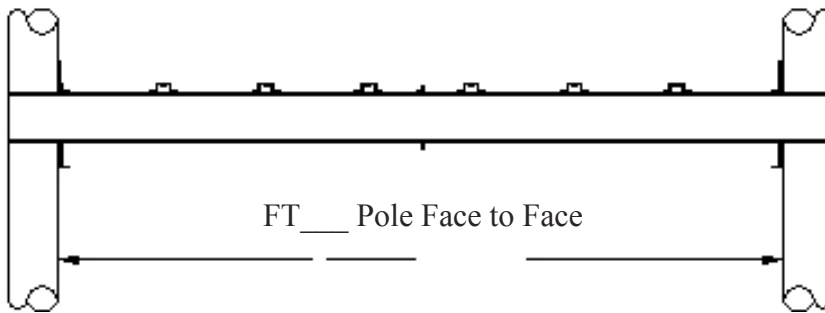

Based on:

- Two beams, each simply supported 12" from each end.
- Type 6061-T6 aluminum alloy extrusion (typical modulus of elasticity – 10,000,000 psi).
- Loads equally spaced between poles.
- Catalog number feet notation equals distance between pole face to pole face for all platforms.

For technical details of special applications call your sales representative.

Vertical Load Capacity

Catalog Number	Walkway	Poles	Uniform Vertical Load (lbs)	Center Vertical Load (lbs)	Three Vertical Load (lbs)
BP-122	None	2	8,000	5,000	2,000
BP-122-wky	1	2	8,000	5,000	2,000
BP-122-2wky	2	2	8,000	5,000	2,000
BP-142	None	2	6,000	4,000	1,800
BP-142-wky	1	2	6,000	4,000	1,800
BP-142-2wky	2	2	6,000	4,000	1,800
BP-162	None	2	5,000	3,100	1,400
BP-162-wky	1	2	5,000	3,100	1,400
BP-162-2wky	2	2	5,000	3,100	1,400

PLATFORMS ARE SHIPPED ASSEMBLED (standard).

Add suffix "-UNA" to catalog number to order a NON-assembled platform.

HEAVY DUTY PLATFORM 42" WIDE

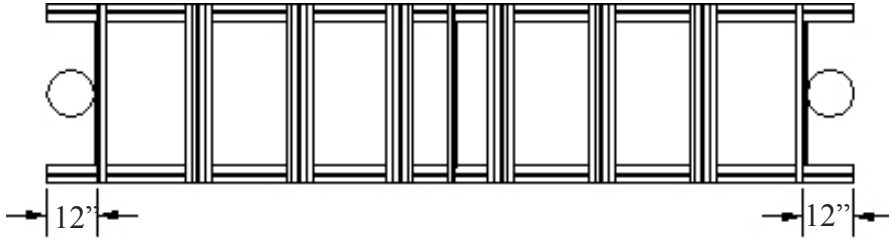

See page C-8 for Switch Fuse Assembly. We do not supply the wood for the walkways.

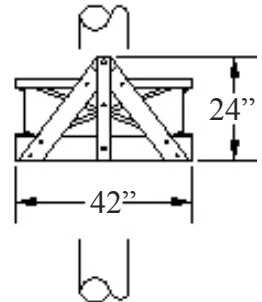
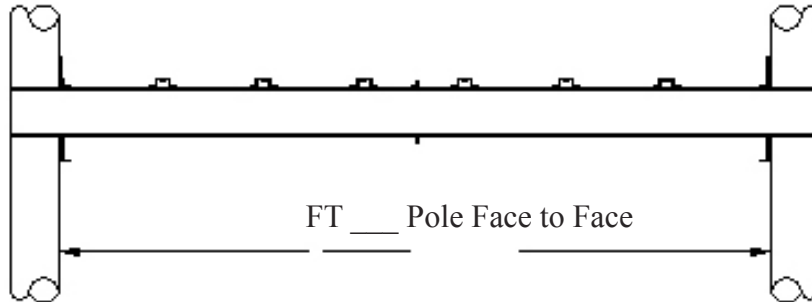

Based on:

- Two beams, each simply supported 12" from each end.
- Type 6061-T6 aluminum alloy extrusion (typical modulus of elasticity – 10,000,000 psi).
- Loads equally spaced between poles.
- Catalog number feet notation equals distance between pole face to pole face for all platforms.

For technical details of special applications call your sales representative.

Vertical Load Capacity

Catalog Number	Walkway	Poles	Uniform Vertical Load (lbs)	Center Vertical Load (lbs)	Three Vertical Load (lbs)
BPHD-142	None	2	14,000	7,500	4,600
BPHD-142-wky	1	2	14,000	7,500	4,600
BPHD-142-2wky	2	2	14,000	7,500	4,600
BPHD-162	None	2	14,000	7,500	4,600
BPHD-162-wky	1	2	14,000	7,500	4,600
BPHD-162-2wky	2	2	14,000	7,500	4,600
BPHD-182	None	2	14,000	7,500	3,700
BPHD-182-wky	1	2	14,000	7,500	3,700
BPHD-182-2wky	2	2	14,000	7,500	3,700

PLATFORMS ARE SHIPPED ASSEMBLED (standard).

Add suffix "-UNA" to catalog number to order a NON-assembled platform.

EXTRA HEAVY DUTY PLATFORM 42" WIDE

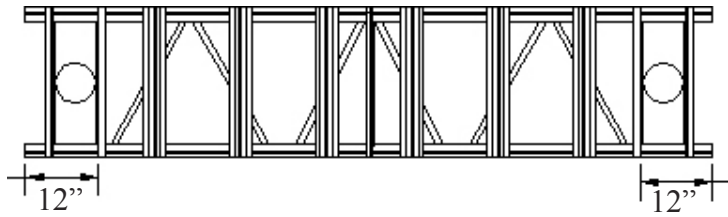

See page C-8 for Switch Fuse Assembly. We do not supply the wood for the walkways.

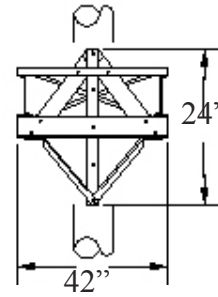
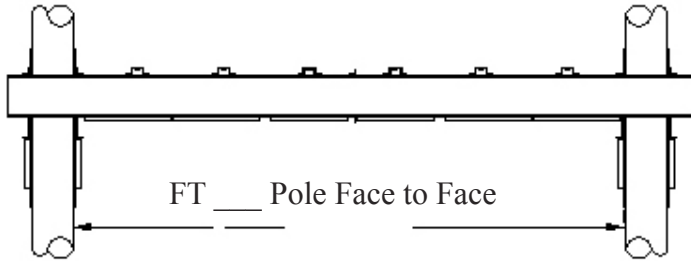

Based on:

- Two beams, each simply supported 12" from each end.
- Type 6061-T6 aluminum alloy extrusion (typical modulus of elasticity – 10,000,000 psi).
- Loads equally spaced between poles.
- Catalog number feet notation equals distance between pole face to pole face for all platforms.

For technical details of special applications call your sales representative.

Vertical Load Capacity

Catalog Number	Walkway	Poles	Uniform Vertical Load (lbs)	Center Vertical Load (lbs)	Three Vertical Load (lbs)
BPEHD-142	None	2	22,000	10,000	6,220
BPEHD-142-wky	1	2	22,000	10,000	6,220
BPEHD-142-2wky	2	2	22,000	10,000	6,220
BPEHD-162	None	2	17,742	10,000	4,667
BPEHD-162-wky	1	2	17,742	10,000	4,667
BPEHD-162-2wky	2	2	17,742	10,000	4,667
BPEHD-182	None	2	13,813	8,633	3,700
BPEHD-182-wky	1	2	13,813	8,633	3,700
BPEHD-182-2wky	2	2	13,813	8,633	3,700
BPEHD-202	None	2	11,058	6,911	2,909
BPEHD-202-wky	1	2	11,058	6,911	2,909
BPEHD-202-2wky	2	2	11,058	6,911	2,909

PLATFORMS ARE SHIPPED ASSEMBLED (standard).

Add suffix “-UNA” to catalog number to order a NON-assembled platform.

SUPER EXTRA HEAVY DUTY PLATFORM 48" WIDE



See page C-8 for Switch Fuse Assembly. We do not supply the wood for the walkways.

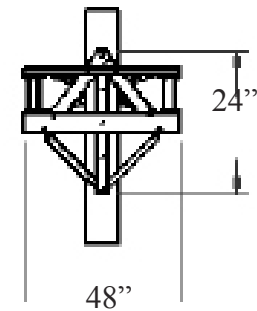
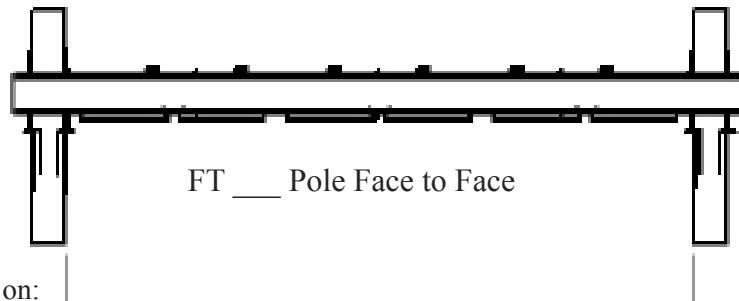

Based on:

- Two beams, each simply supported 12" from each end.
- Type 6061-T6 aluminum alloy extrusion (typical modulus of elasticity – 10,000,000 psi).
- Loads equally spaced between poles.
- Catalog number feet notation equals distance between pole face to pole face for all platforms.

For technical details of special applications call your sales representative.

Vertical Load Capacity

Catalog Number	Walkway	Poles	Uniform Vertical Load (lbs)	Center Vertical Load (lbs)	Three Vertical Load (lbs)
BPSEHD-142	None	2	33,000	20,000	10,400
BPSEHD-142-wky	1	2	33,000	20,000	10,400
BSPEHD-142-2wky	2	2	33,000	20,000	10,400
BPSEHD-162	None	2	21,000	18,000	9,334
BPSEHD-162-wky	1	2	31,000	18,000	9,334
BPSEHD-162-2wky	2	2	31,000	18,000	9,334
BPSEHD-182	None	2	27,262	17,266	7,266
BPSEHD-182-wky	1	2	27,262	17,266	7,266
BPSEHD-182-2wky	2	2	27,262	17,266	7,266
BPSEHD-202	None	2	22,116	13,822	5,818
BPSEHD-202-wky	1	2	22,116	13,822	5,818
BPSEHD-202-2wky	2	2	22,116	13,822	5,818
BPSEHD-222	None	2	18,104	11,314	4,762
BPSEHD-222-wky	1	2	18,104	11,314	4,762
BPSEHD-222-2wky	2	2	18,104	11,314	4,762

PLATFORMS ARE SHIPPED ASSEMBLED (standard).

Add suffix "-UNA" to catalog number to order a NON-assembled platform.

PLATFORMS

BPHD-WKY

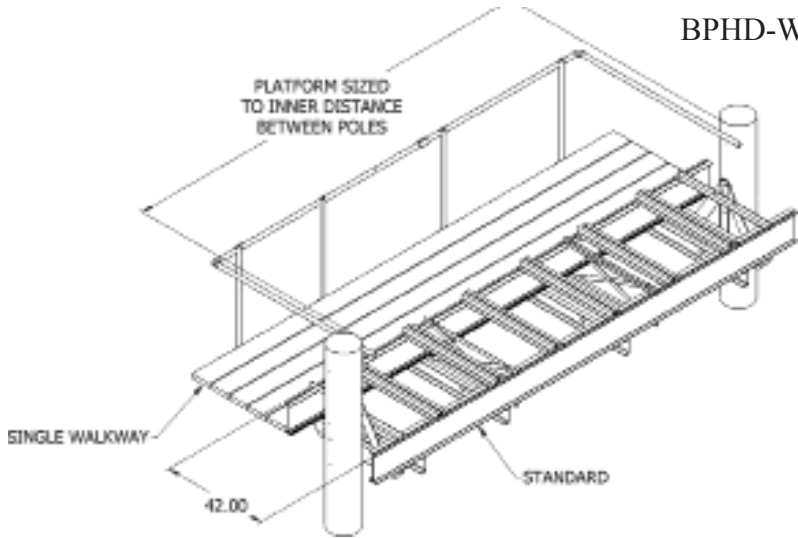

BPSEHD-2 WKY

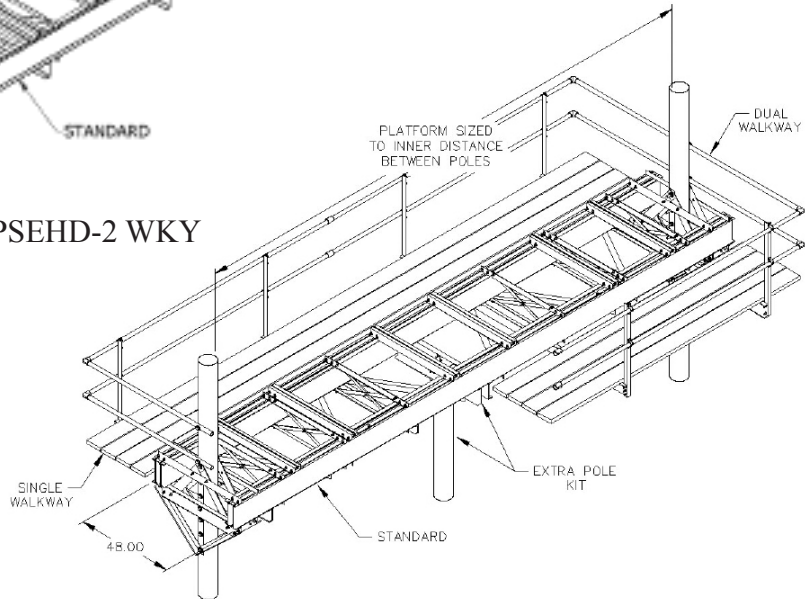

BPEHD-2 WKY

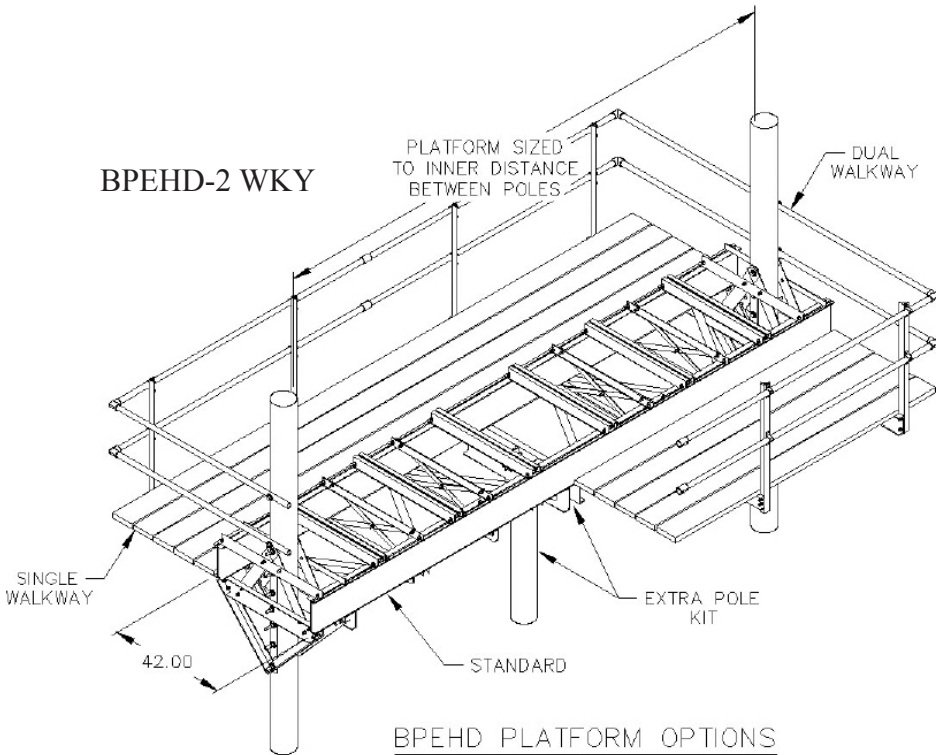

BPEHD PLATFORM OPTIONS

ALUMINUM EXTRA POLE KITS

REGULAR HEAVY DUTY and EXTRA HEAVY DUTY

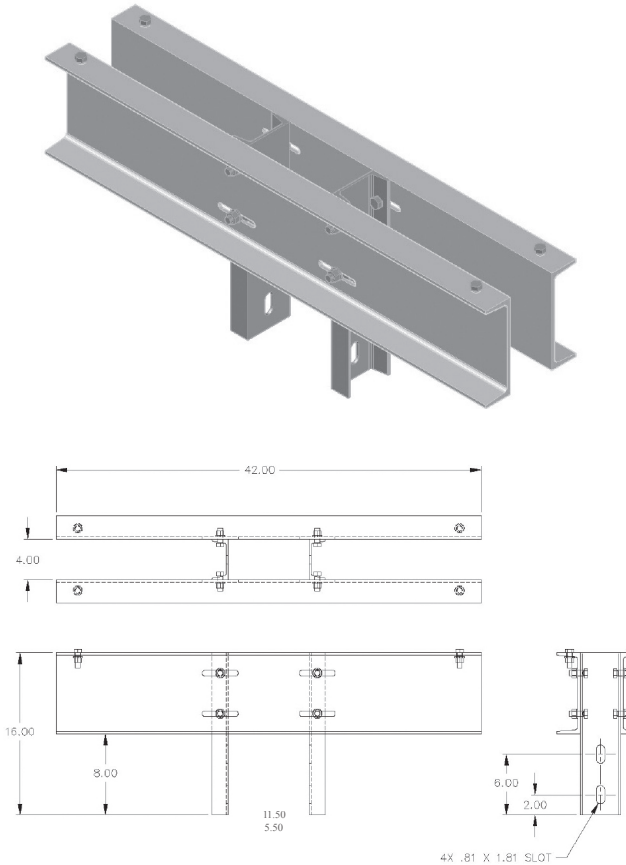

Catalog Number	For use with:
BPEPK-HD-EHD	BP
	BPHD
	BPEHD

3/4" thru-bolts with flat and lock washers are suggested for the above application. Mounting hardware not supplied with platform pole kit.

SUPER EXTRA HEAVY DUTY POLE KIT

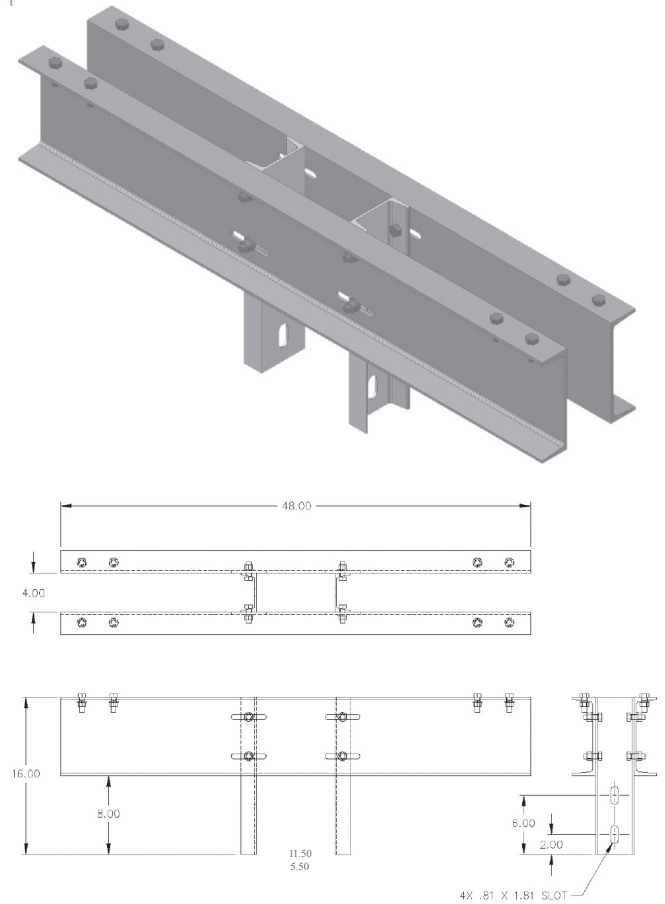

Catalog Number	For use with:
BPEPK-SEHD	BPSEHD

3/4" thru-bolts with flat and lock washers are suggested for the above application. Mounting hardware not supplied with platform pole kit.

OVERHEAD SWITCH SUPPORT MEMBER

BAOHSM SWITCH FUSE ASSEMBLY

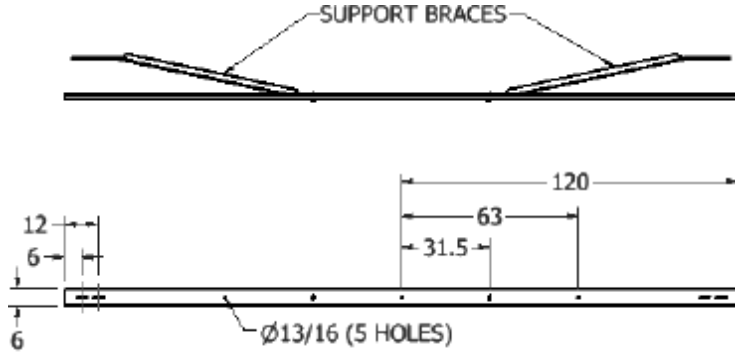

BAOHSM	A	B	C
14 FT	14'-0"	14'-2"	15'-2"
16 FT	16'-0"	16'-2"	17'-2"
18 FT	18'-0"	18'-2"	19'-2"
19 FT	19'-0"	19'-2"	20'-2"
20 FT	20'-0"	20'-2"	21'-2"
22 FT	22'-0"	22'-2"	23'-2"
24 FT	24'-0"	24'-2"	26'-2"
25 FT	25'-0"	25'-2"	22'-2"

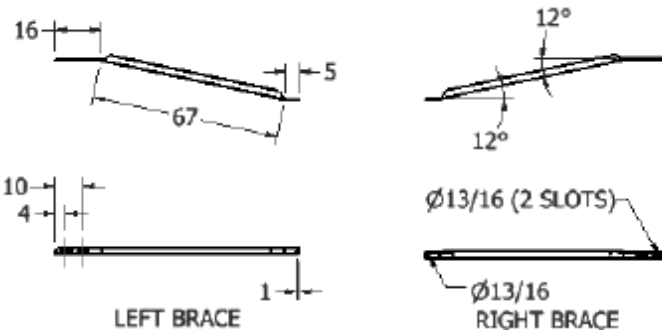

Can be purchased as a single or in pairs.
Please specify when ordering.

BASMAHC HEAVY DUTY SWITCH FUSE ASSEMBLY

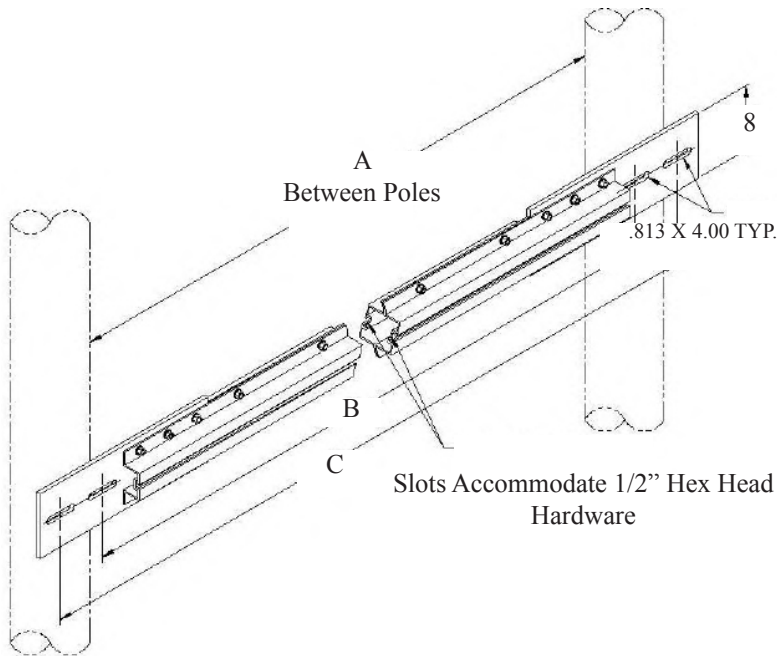

BASMAHC	A	B	C
14 FT	14'-0"	14'-2"	15'-2"
16 FT	16'-0"	16'-2"	17'-2"
18 FT	18'-0"	18'-2"	19'-2"
19 FT	19'-0"	19'-2"	20'-2"
20 FT	20'-0"	20'-2"	21'-2"
22 FT	22'-0"	22'-2"	23'-2"
24 FT	24'-0"	24'-2"	26'-2"
25 FT	25'-0"	25'-2"	22'-2"

TIE DOWN KIT

BATTDK - Tie Down Kit

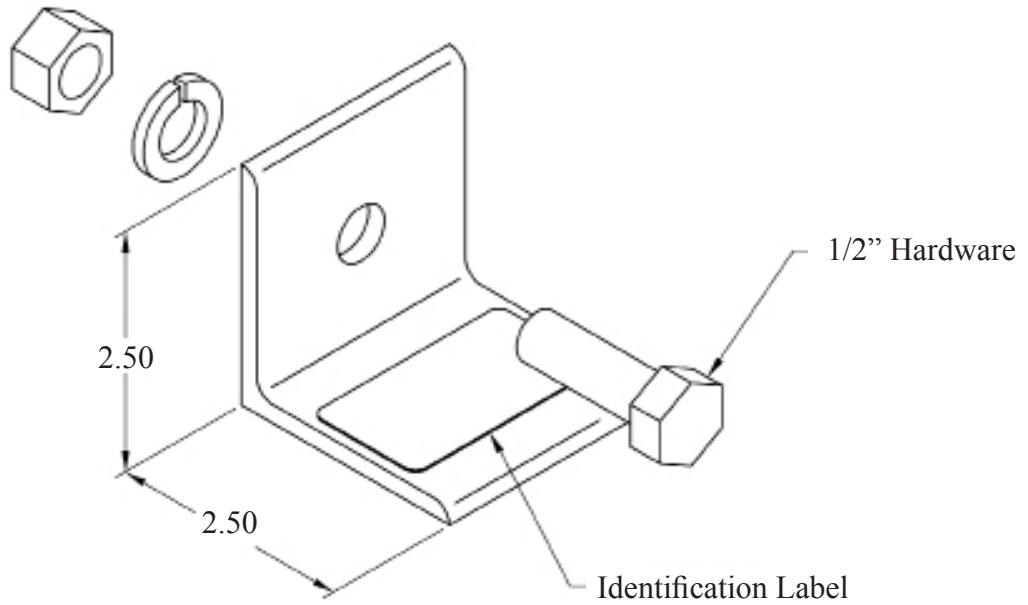

One kit per transformer or recloser is necessary.