

BEACONS

For VoIP Telephones: 5 & 11 Joule



- High energy xenon strobe beacon
- Long-life xenon tube - typically > 20,000,000 flashes
- 230vAC 5 & 11 Joule model
- Repetitive Dual Flash (DH) model
- 360° All-round and 270° All-over visibility

Xenon Beacons

Innovative industrial hazard warning beacon with optimised external lens ribbing to maximise available light transfer for enhanced long-range visibility.

The beacon incorporates fixing drillouts on 51mm centres for direct conduit box mounting (gasket supplied) with alternative 3 drillouts on 100mm PCD. Central 20mm drillout in base for cable entry. High grade engineering, UV-stabilised plastics (ABS Base, Polycarbonate Lens).

The beacons are used in many applications with the GAI-Tronics products and systems.

These beacons are compatible with GAI-Tronics' VoIP telephones. Please see brochure B098 for analogue telephone options. Units can be ordered to customer specification - our Commercial Team can advise which beacon is best suited to your needs.

11 Joule Model

ORDER CODE LENS COLOUR

986-07-0024-302 RED
986-07-0024-303 AMBER
986-07-0024-305 GREEN (shown)
986-07-0024-306 BLUE
986-07-0024-309 CLEAR

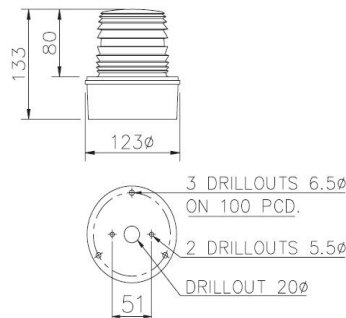

Supply voltage	230V ac
Supply current	80mA
Flash event	DH or SH
Flash rate adjustment	30, 45, 60, 90 fepm
Flash Energy	11J
Temperature limits	-40° C +55° C
IEC protection class	IP65

Dimensions

Ht of beacon	133
Ht of dome	80
Diameter of base	123

5 Joule Model

986-07-0601-252 RED
986-07-0601-253 AMBER
986-07-0601-255 GREEN
986-07-0601-256 BLUE
986-07-0601-259 CLEAR

www.gai-tronics.co.uk



UK: Tel: +44 (0) 1283 500500
USA: Tel: +1 (610) 777-1374
Italy: Tel: +39 02 4860 1460
Malaysia: Tel: +60-3-8945-4035
Australia: Tel: +61-28-851-5000

www.gai-tronics.co.uk
www.gai-tronics.com
www.gai-tronics.it
www.gai-tronics.com
www.austdac.com.au

