



# HEAVY DUTY CAST FLUSH WEATHER- PROOF COVER

## Application

BELL Heavy Duty Flush Covers provide weatherproof protection from the elements. They are lockable to keep unauthorized users out. The covers easily mount to any 3-3/4" through 4-11/16" square box.

## Features

- Heavy Duty Cast Aluminum Construction with Durable Enamel Paint
- Cobra Cam lock, key removal in locked and unlocked positions
- 2 keys provided
- 4-in-1 configuration
- Irradiation crosslinked polyethylene foam gasket
- Mounting hardware included
- Adapters included for various devices

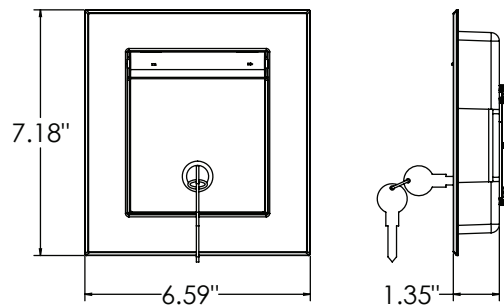
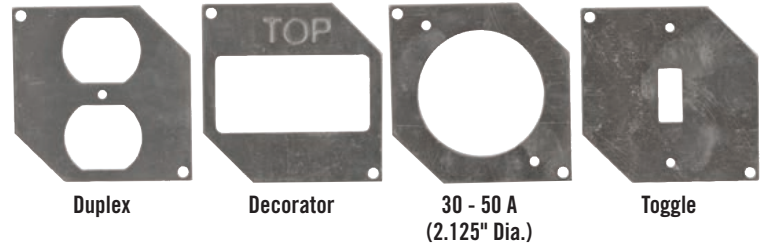

Scan to see the video



Catalog No.	Description	Inner Pk. Qty.	Carton Dimensions			UPC-A Bar Code
			Length	Width	Height	
4600RAC	Heavy Duty Cast Aluminum Cover mounts 3-3/4" through 4-11/16" Sq. box	1	7.75"	7"	1.75"	050169500941