



*Commercial, Industrial  
and Residential Electrical Products*



# Outdoor Comforts™

*Enhance Your Outdoor Space!*

## OUTDOOR CEILING FAN AND LUMINAIRE BOX

### Application

Provides a safe and secure mounting and weatherproof wiring junction for outdoor fans, chandeliers or pendant lights. Part of Bell's Outdoor Comforts™ line, this electrical box is designed to enhance outdoor living spaces with the same convenience and comfort as indoors. Perfect for porches, covered patios, pergolas.

### Features

- Support fans up to **70lbs** or heavy luminaires up to **150lbs**
- Five 3/4in threaded entries for conduit or fittings with four closure plugs
- Includes three reducer bushings (3/4in to 1/2in)
- Box mounts parallel, perpendicular or 45° from a joist
- Constructed of heavy duty PVC with integrated galvanized steel support bracket

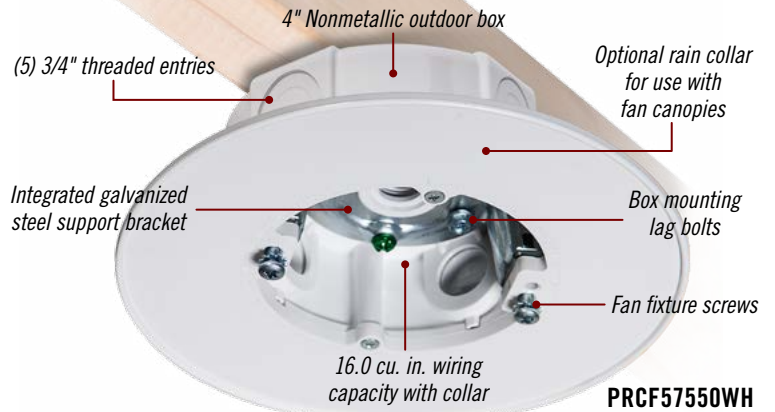

**Safe & Secure**  
with a properly rated box!

NEC & NEMA 3R Compliant



CAT. #	DESCRIPTION	CUBIC IN. CAPACITY (When used with collar)	THREADED ENTRIES	RECOMMENDED MAX. LOADS		STD. PKG.	UPC A BAR CODE
				CEILING FAN (DYNAMIC) LBS.	FIXTURE (STATIC) LBS.		
<b>4" Nonmetallic Outdoor Round Box, 1-1/2" Deep – Heavy Duty PVC with Integrated Galvanized Steel Support Bracket</b>							
PRCF57550GY	Ceiling fan/luminaire box, Gray	16.0"	(5) 3/4" or 1/2"	70	150	4	
PRCF57550WH	Ceiling fan/luminaire box, White	16.0"	(5) 3/4" or 1/2"	70	150	4	
PRCF57550BZ	Ceiling fan/luminaire box, Bronze	16.0"	(5) 3/4" or 1/2"	70	150	4	



**COMMERCIAL CONSTRUCTION**  
A Division of Hubbell Incorporated (Delaware)

**BELL**  
2520 E. University Dr.  
Tempe, AZ 85281  
800-526-5416  
[www.hubbell.com/bell/en](http://www.hubbell.com/bell/en)

