

# GLEASON® - DHG SERIES CONDUCTOR BAR SYSTEMS

## FEATURES:

- SAFE CONTINUOUS CONTACT
- SMALL PROFILE FOR COMPACT INSTALLATIONS
- ECONOMICAL
- SELF-EXTINGUISHING ENCLOSURE
- 600 V AC / 600 V DC WORKING VOLTAGE
- -40° TO 120°C (-40° TO 248°F)

## APPLICATIONS:

- MACHINE TOOLS
- AUTOMATED STORAGE / RETRIEVAL SYSTEMS
- WORKSHOPS
- HOISTS
- CIRCULAR INSTALLATIONS



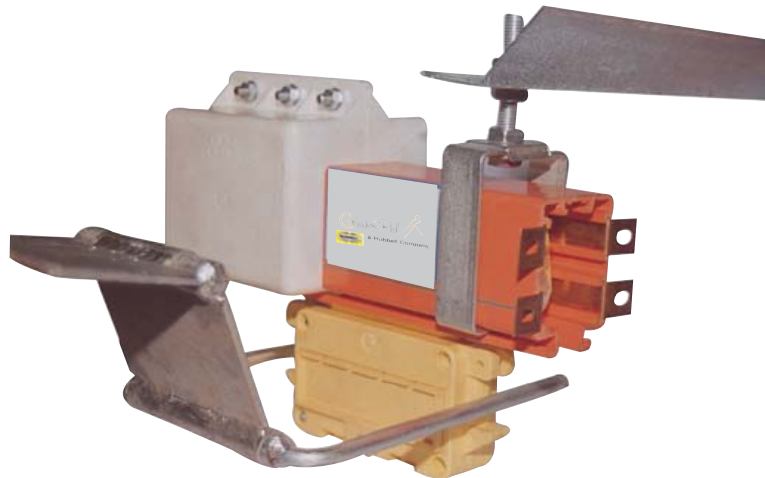

<b>MODEL NUMBER</b>	<b>RATED CURRENT AMPS</b>	<b>NO. OF POLES</b>	<b>RAIL LENGTH M (FT)</b>	<b>MAXIMUM SPEED/MIN. M (FT)</b>	<b>HANGER SPACING M (FT)</b>
DHG4-10/50	50	4	4 (13.12)	250 (820)	.5 to 1.8 (1.64 to 5.9)
DHG6-10/50	50	6	4 (13.12)	250 (820)	.5 to 1.8 (1.64 to 5.9)
DHG7-10/50	50	7	4 (13.12)	250 (820)	.5 to 1.8 (1.64 to 5.9)
DHG4-16/80	80	4	4 (13.12)	250 (820)	.5 to 1.8 (1.64 to 5.9)
DHG6-16/80	80	6	4 (13.12)	250 (820)	.5 to 1.8 (1.64 to 5.9)
DHG7-16-80	80	7	4 (13.12)	250 (820)	.5 to 1.8 (1.64 to 5.9)
DHG4-35/140	140	4	4 (13.12)	250 (820)	.5 to 1.8 (1.64 to 5.9)
DHG4-50/170	170	4	4 (13.12)	250 (820)	.5 to 1.8 (1.64 to 5.9)
DHG3-70/210	210	3	4 (13.12)	250 (820)	.5 to 1.8 (1.64 to 5.9)
DHG4-70/210	210	4	4 (13.12)	250 (820)	.5 to 1.8 (1.64 to 5.9)
DHG3-95/280	280	3	4 (13.12)	250 (820)	.5 to 1.8 (1.64 to 5.9)

Collector Assembly:

MODEL NUMBER	RATED CURRENT AMPS	NO. OF POLES	MODEL NUMBER	RATED CURRENT AMPS	NO. OF POLES	MODEL NUMBER	RATED CURRENT AMPS	NO. OF POLES
JS4-10/50	50	4	JS4-16/80	80	4	JS4-35/140	140	4
JS6-10/50	50	6	JS6-16/80	80	6	JS4-50/170	170	4
JS7-10/50	50	7	JS4716/80	80	7	JS4-70/210	210	3
						JS4-70/210	210	4
						JS4-95/280	280	3

Mounting Method:

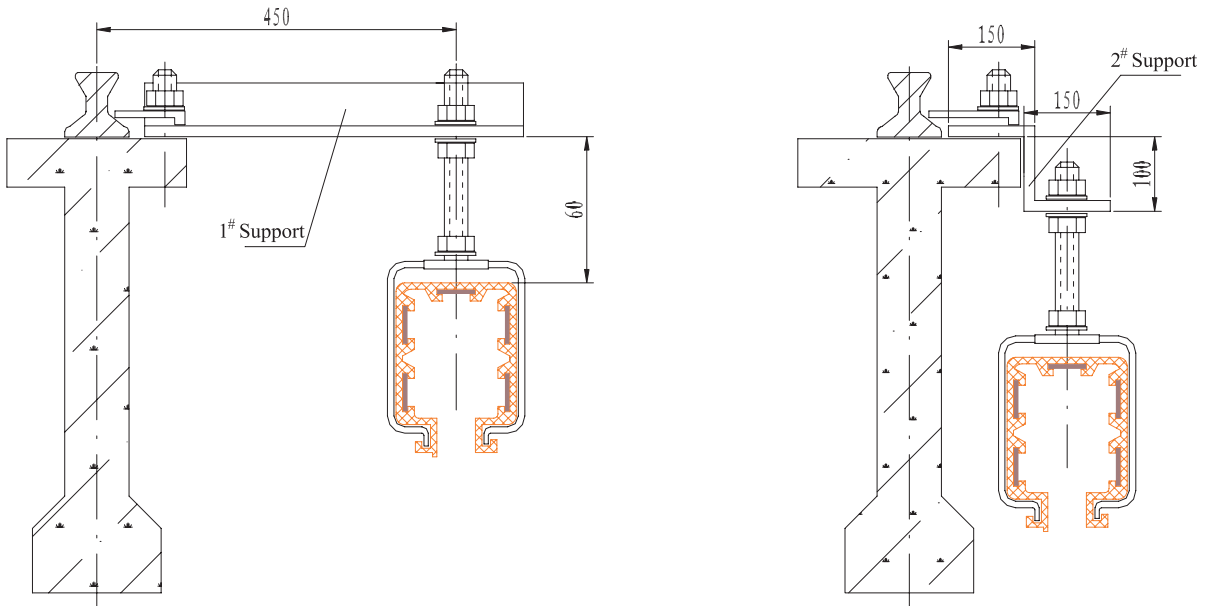

## APPLICATION & PRODUCT PHOTOS

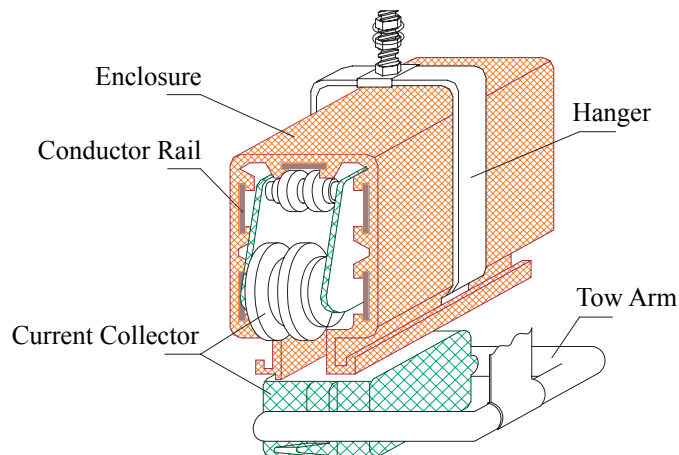

**Gleason Reel Corp.**  
600 S. Clark St.  
Mayville, WI 53050  
PH 920-387-4120 | FAX 920-387-4189  
[www.hubbell-gleason.com](http://www.hubbell-gleason.com)

DHGCB1011