



GLEASON® - JD100 SERIES CONDUCTOR BAR SYSTEMS

FEATURES:

- SAFE, COMPACT AND EASILY ASSEMBLED
- SINGLE ENCLOSURE “H” CONDUCTOR
- GALVANIZED STEEL
- VERTICAL OR HORIZONTAL INSTALLATION
- 600 V AC / 600 V DC WORKING VOLTAGE
- UP TO 110 AMPS CONTINUOUS DUTY RATING
- SINGLE BOLT ANCHORING
- WATER AND DUST RESISTANT ENCLOSURES
- -25° TO 85°C (-13° TO 185°F)

APPLICATIONS:

- OVERHEAD CRANES
- HOISTS
- STEEL MILLS
- SHIPBUILDING
- INDUSTRIAL PLANTS
- POWER PLANTS
- WAREHOUSES
- CONTAINER PORTS
- GENERAL INDUSTRY

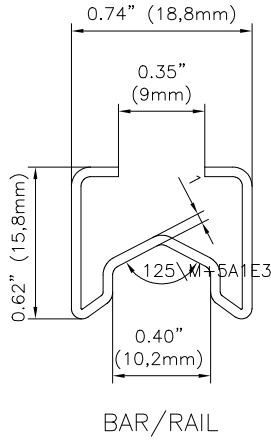

Model No. **JDC-K-1**

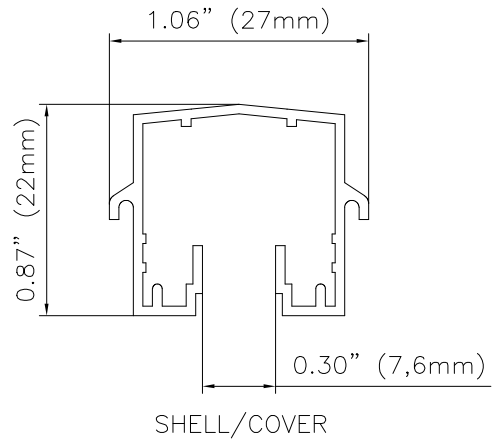

MODEL NUMBER	RATED CURRENT	RAIL LENGTH M (FT)	MAXIMUM SPEED/MIN. M (FT)	HANGER SPACING M (FT)	BAR SPACING CL TO CL MM (IN)	EXPANSION JOINT M (FT)	ENCLOSURE MM (IN)
JD100	110	4.5 (14.8)	300 (984)	1.2 (3.94)	45.5 (1.79)	100 (328)	27 x 22 (1.06 x .87)

4 Bar, Single Bolt Hanger:

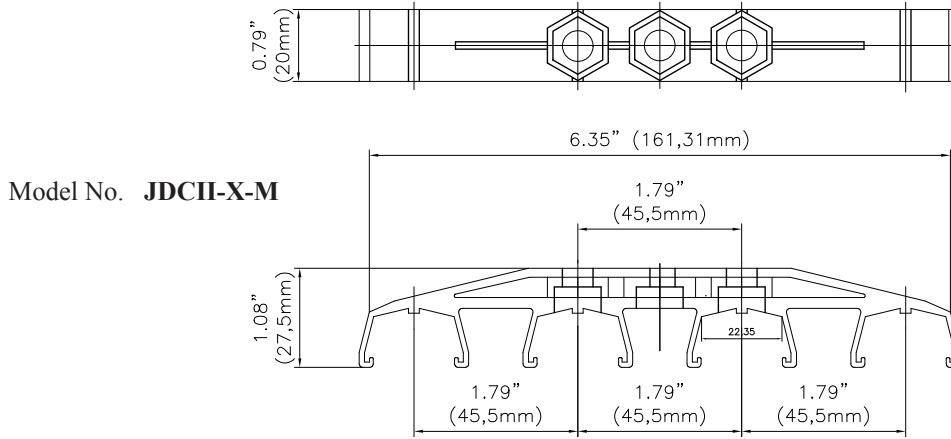

Single Hanger / Anchor:

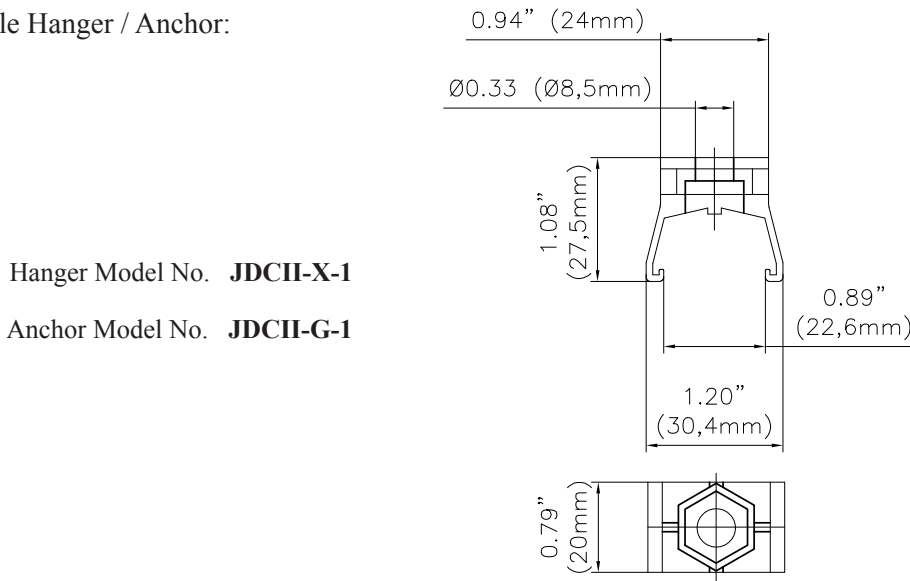

Mounting Brackets:

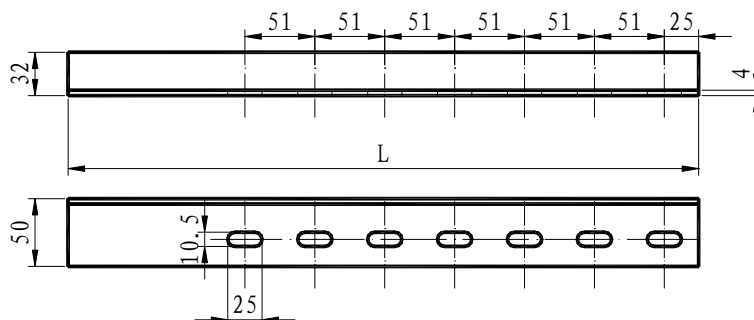

Model	L mm (in)
JDS-460	460 (18)
JDS-535	535 (21)
JDS-610	610 (24)

Single / Tandem Current Collector:

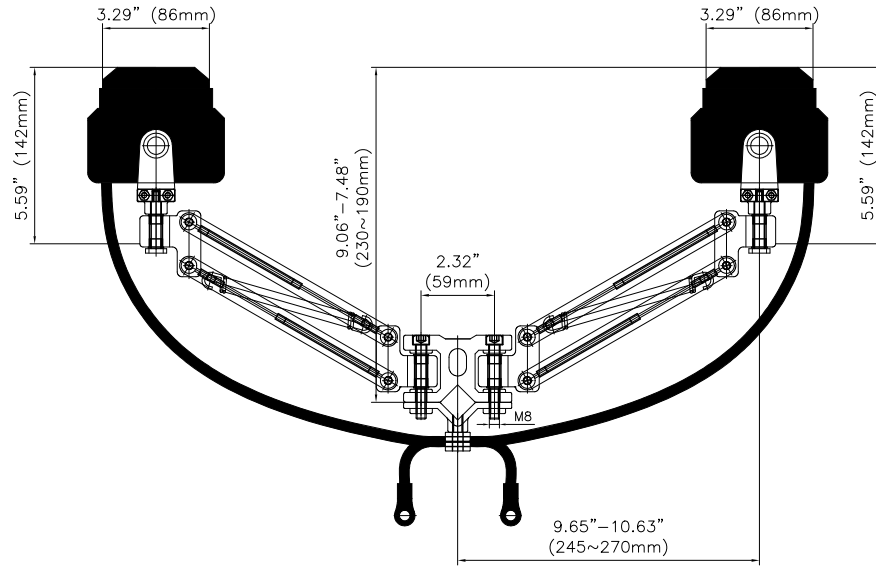

MODEL NUMBER Single Collector	RATED CURRENT	SHUNT SIZE	MAXIMUM SPEED M/MIN (FT. MIN.)	COLLECTOR HEAD MOVEMENT Horizontal / Vertical (in)	CONNECTOR ARM TO BAR	WEIGHT SINGLE SHOE
JD-150	150	16 mm ²	300 (984)	± 20 / ± 20 (.78 / .78)	250 mm (10")	2.2 kg (4.85 lbs.)

Joint Connector:

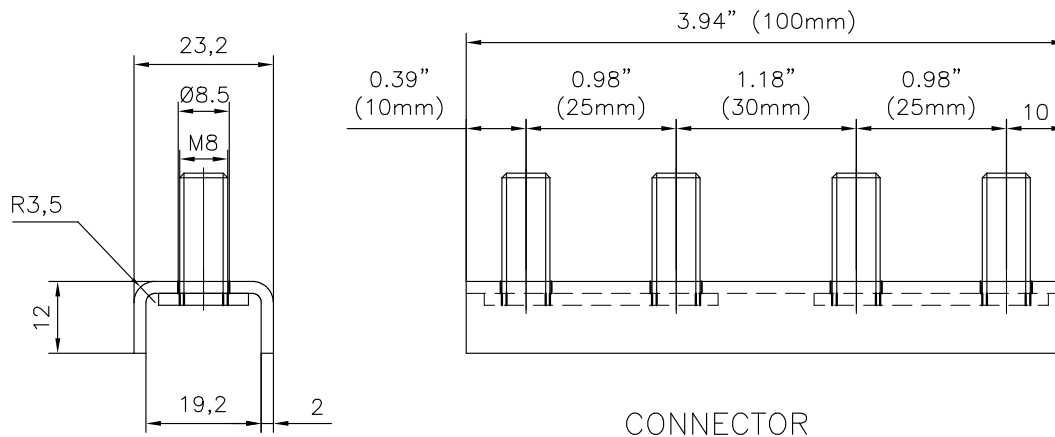

CONNECTOR

Joint Connector Cover:

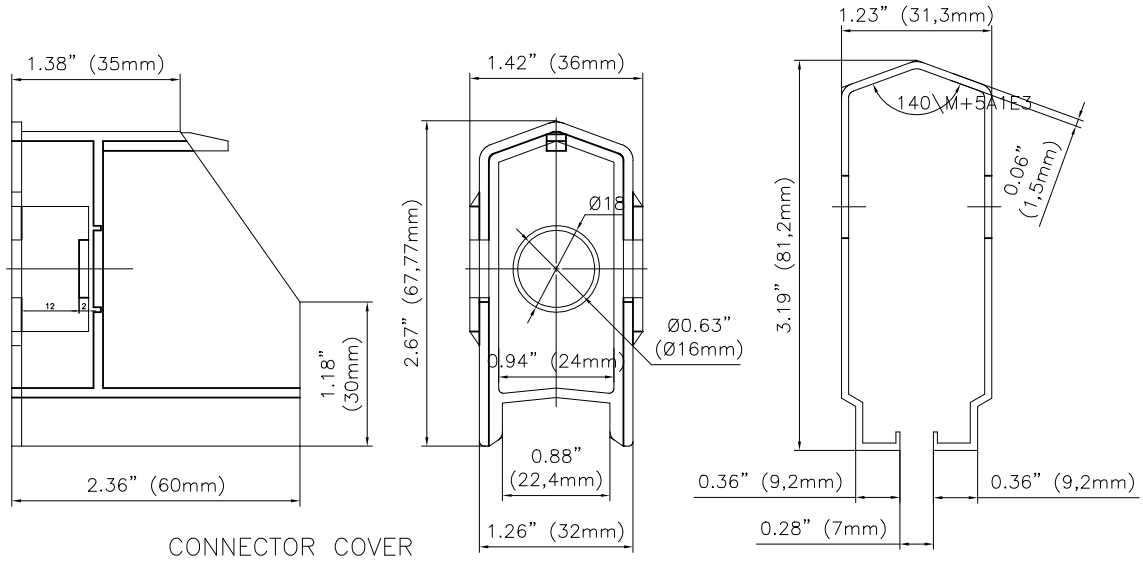

Model No. **JDC-AL-I**

End Caps:

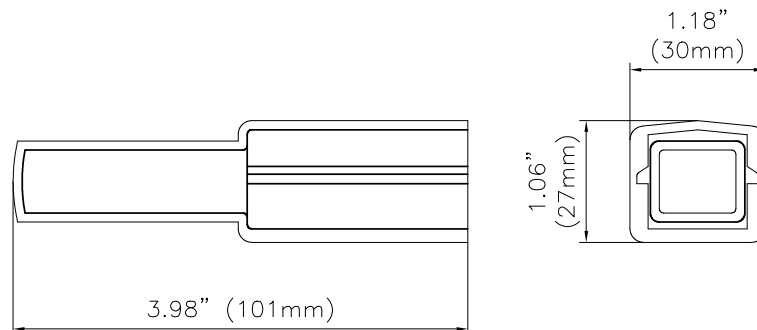

Model No. **JDC-D-I**

Maintenance Section:

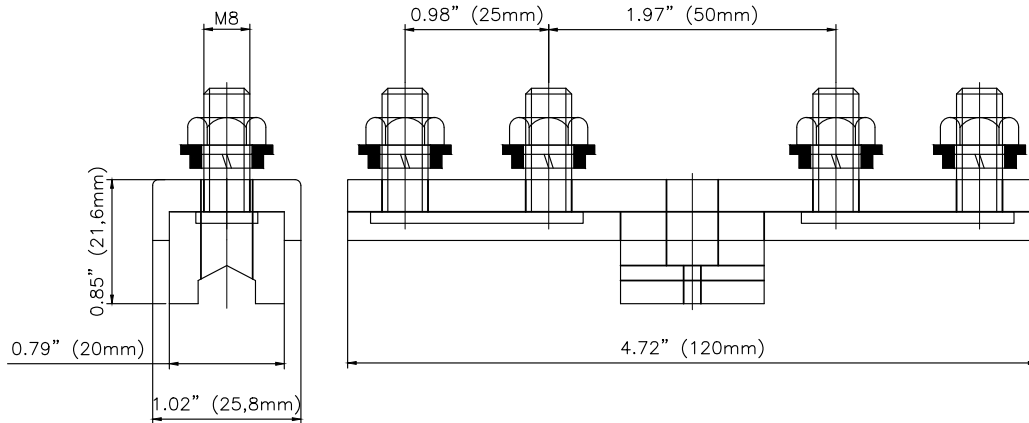
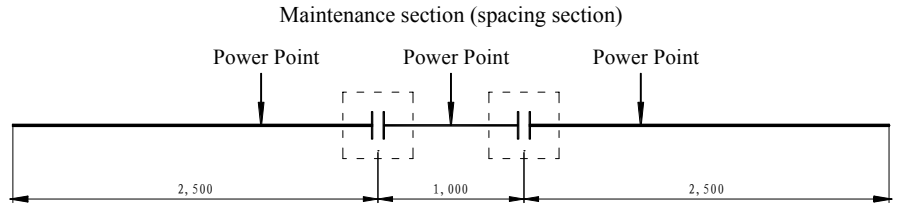
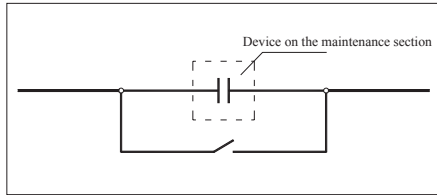

Expansion Section:

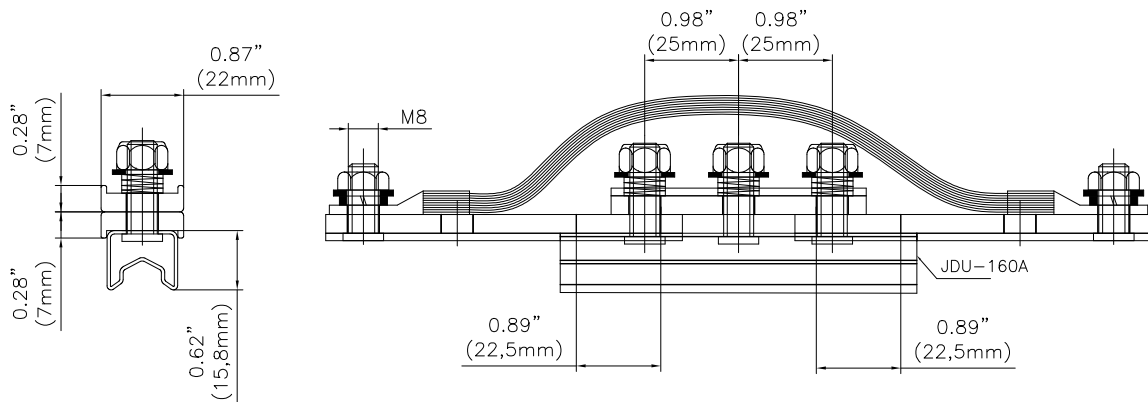

APPLICATION PHOTOS

