

# HIGH AMP 400

400 Ampere

600 Volt

3.5"(89mm)Bore

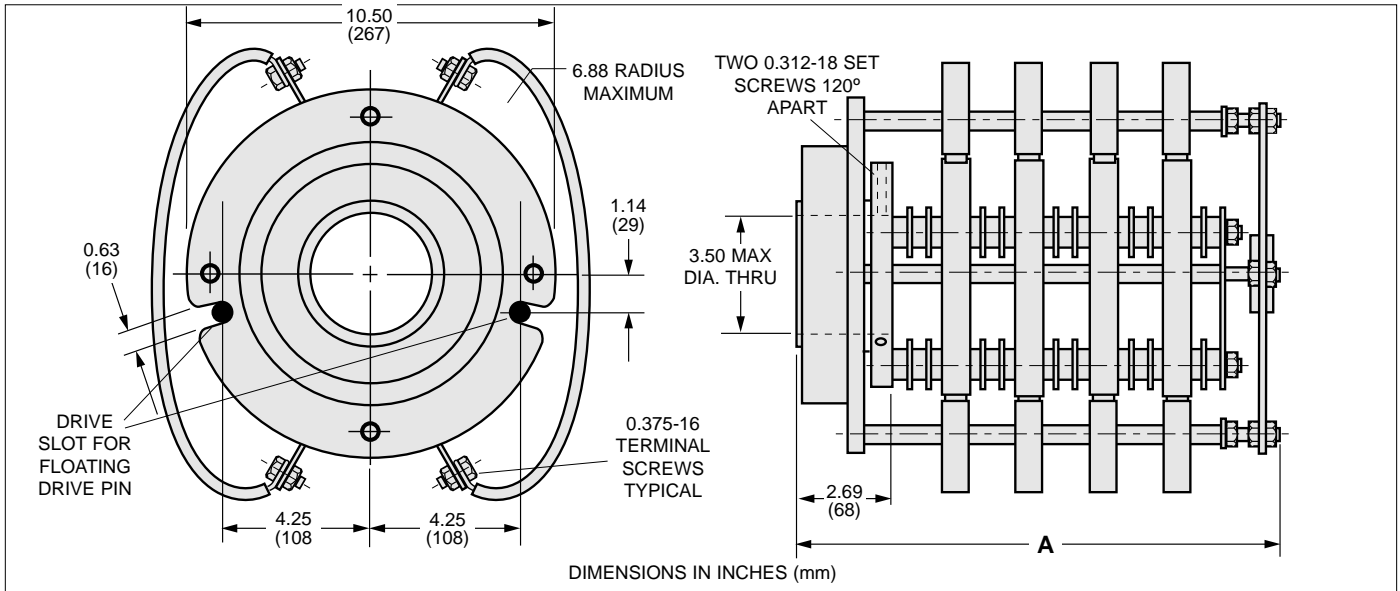

- **RINGS:** Copper alloy for best combination of conductivity and durability. Wide contact area for maximum reliability.
- **BRUSHES:** Double copper graphite, four per ring, machined to precisely match ring radius.
- **BRUSH SPRINGS:** Stainless steel. Maintain proper tension through full rotation.
- **BRUSH HOLDERS:** Brass; hold twin brushes.
- **SHUNT WIRES:** Braided copper.
- **INSULATORS:** Phenolic spacers mounted on three tie-rods. Air gap acts as a natural insulator between phases.
- **BEARINGS:** Double, sealed ball bearings for maximum durability. Optional low speed bearings.
- **DRIVE COLLAR:** Zinc plated steel resists corrosion.
- **SPEED:** Nominal 300 rpm.
- **ENCLOSURES:** Durable steel with polyester powder baked-on finish exceeds even zinc plating. Custom coatings available. Consult factory for details.

## 400 AMP SLIP-RINGS

Model Number	Number Poles	Assembled Length (A) in. (mm)
HA400-02	2	9.75 (248)
HA400-03	3	11.88 (302)
HA400-04	4	14.00 (356)
HA400-05	5	16.13 (410)

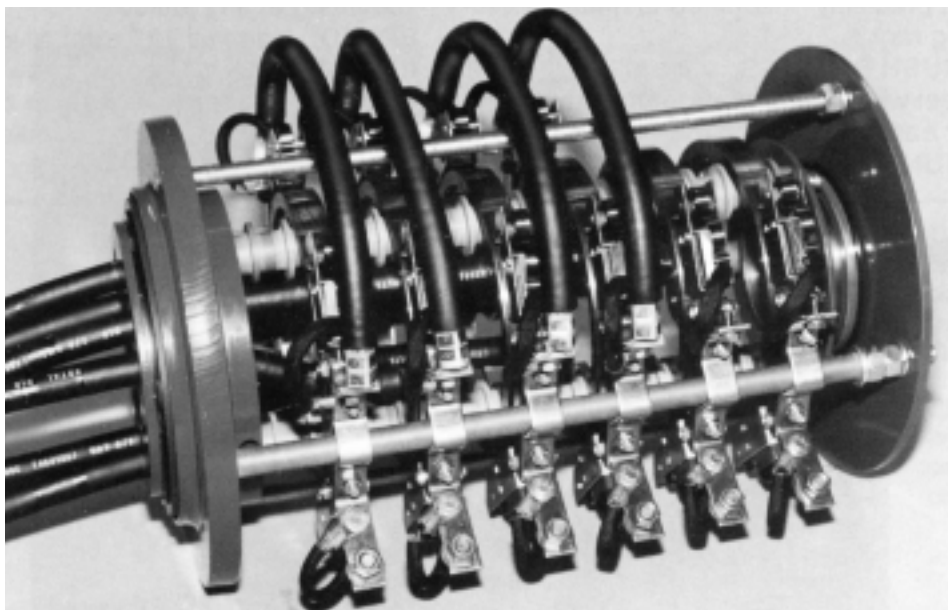

\* Unless otherwise specified, standard assemblies are supplied with lead wires as indicated, derated per lead wire limits and per number of poles. If larger or mixed lead wires are required or for high-temp use (<200°C), please contact us.

Typical High Amp Slip-ring