

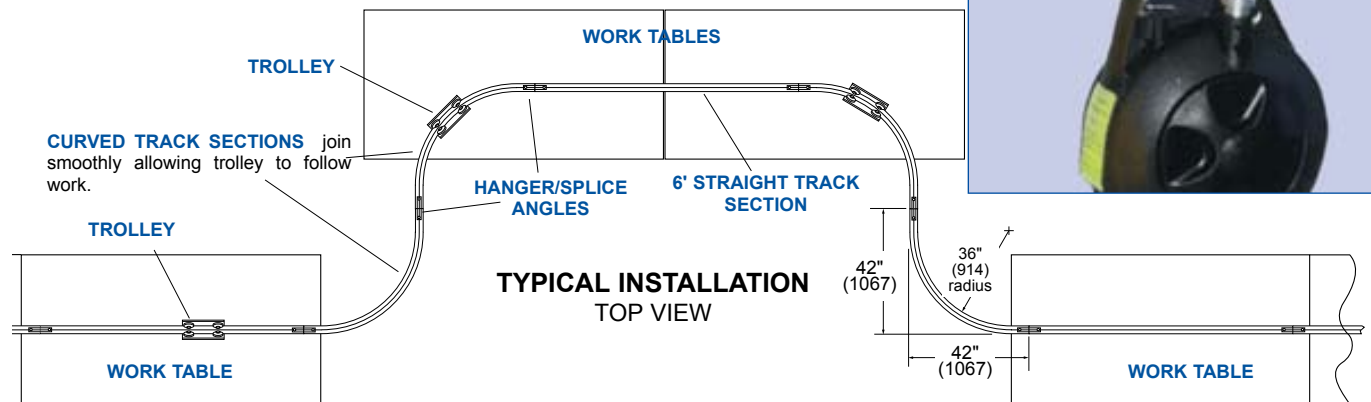

CURVED RAIL FOLLOWS THE WORK GUIDES TOOLS AND CONTROLS AROUND CORNERS

UNIQUE DIAMOND RAIL track and matching trolleys allow tools or control boxes to follow assembly line or conveyor path. Curved sections with 3 ft. (0.9m) radius form 90° corner and connect to other curved or straight track sections for smooth, non-stop trolley movement. Design and build your own system from components shown below. Threaded hangers may be hung from overhead beams or from WS50 rail using standard track nut. Trolleys include safety flanges to prevent fall if rollers fail. Capacity 30 lbs. (13.5 Kg).

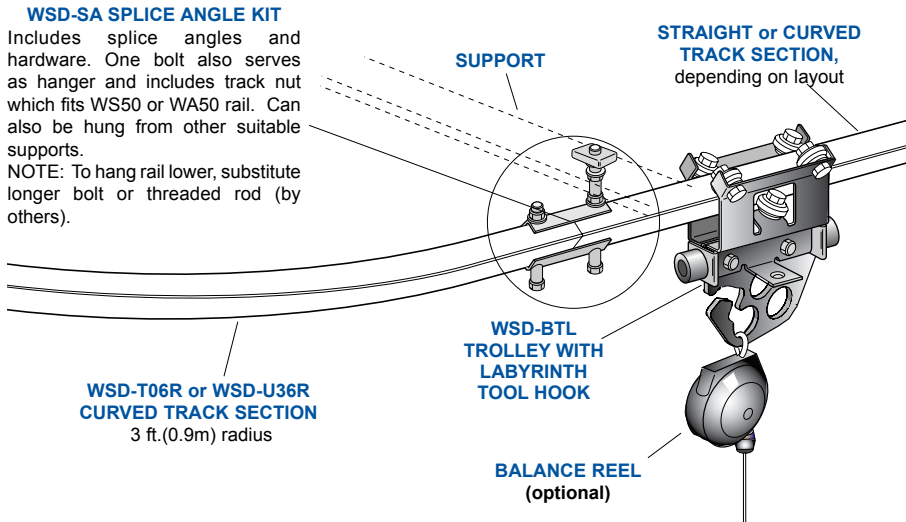

COMPONENT CHART		
DESCRIPTION	FINISH	MODEL NO.
6' (1.8m) STRAIGHT TRACK SECTION	BEIGE POLYESTER	WSD-T06
	UNFINISHED	WSD-U06
90° x 36" (914 mm) RADIUS CURVED TRACK SECTION	BEIGE POLYESTER	WSD-T36R
	UNFINISHED	WSD-U36R
SPLICE ANGLE KIT (includes (2) angles, hanger bolt, splice bolt, nuts & washers)	ZINC PLATED	WSD-SA
END STOP KIT (right, top) (includes end stop, hanger bolt, nuts & washers)	ZINC PLATED	WSD-ES
TROLLEY-LABYRINTH TOOL HOOK	BLACK POLYESTER	WSD-BTL
FESTOON TRAILER TROLLEY*	BLACK POLYESTER	WSD-RC12

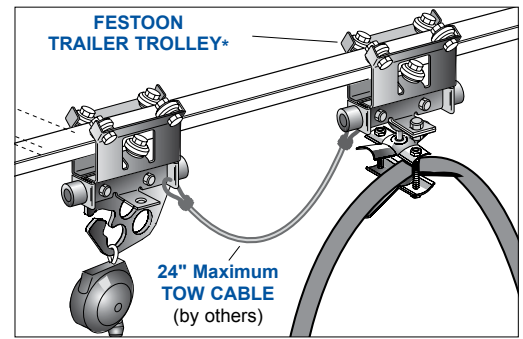
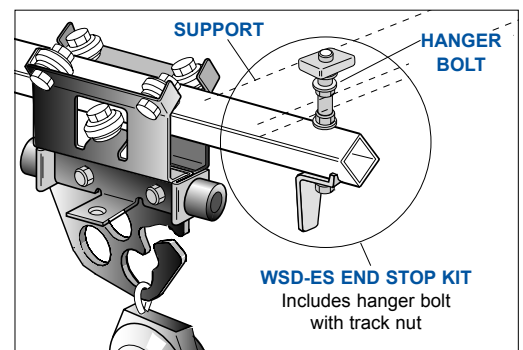

* **FESTOON TRAILER TROLLEY** (right, bottom) provides easy management of cord or hose supplying power to tool. Fits cable or hose 0.60–0.94" (15–24mm) diameter. Tow cable connecting tool trolley to trailer trolley should not exceed 24" in length.

250 lb. CAPACITY RAIL

FOR THOSE HEAVY DUTY APPLICATIONS

ACCESSORIES



RAIL & HANGER KITS

Designed for large air tool balancers, these tool rail kits are similar to our W3F and W5F tool support kits but much heavier. Must be supported every 6 ft. (1.8m) minimum to maintain full rated capacity.

- The basic tool rail is the key component on which all accessories hang
- Maximum 250 lb.(113kg) safe load rating
- Galvanized for maximum corrosion protection
- Available in 6, 12 and 18 ft. (1.8, 3.6, 5.4m) lengths
- May be joined for any length
- Can be mounted on benches, booms, or ceilings

250 lb. CAPACITY TOOL RAIL KIT includes (1) galvanized steel rail (length per model), (1) heavy duty tool trolley, (2) hanger brackets, and (2) end stops.

WS60-HG HANGER

Supports rail from overhead structures. Does not interfere with free trolley movement. Two mounting holes, .406"(10) sq. for 3/8" carriage bolts

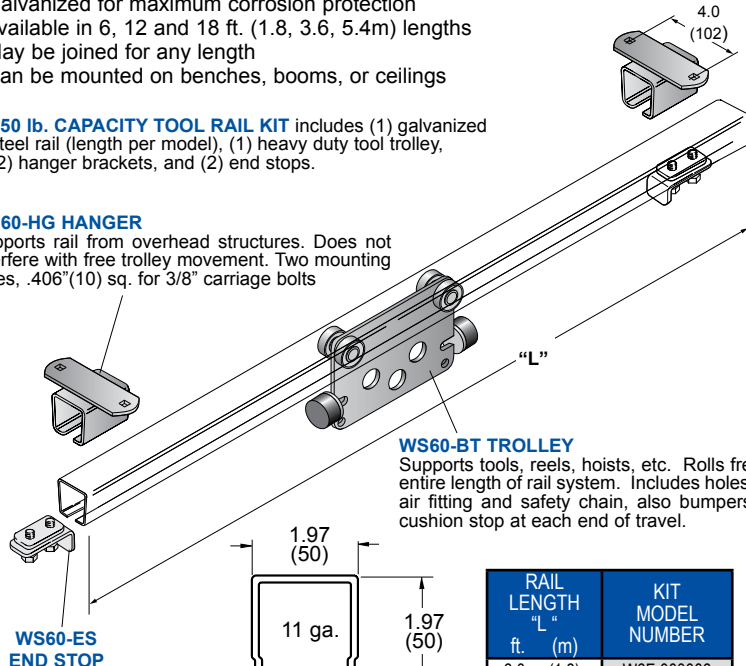

WS60-ES END STOP

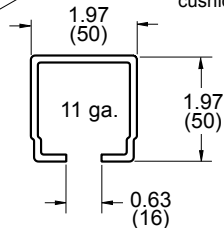

WS60 Rail

For loads up to 250 lbs (113kg).

WS60-BT TROLLEY

Supports tools, reels, hoists, etc. Rolls freely entire length of rail system. Includes holes for air fitting and safety chain, also bumpers to cushion stop at each end of travel.

RAIL LENGTH "L"		KIT MODEL NUMBER
ft.	(m)	
6.0	(1.8)	W6F-000006
12.0	(3.6)	W6F-000012
18.0	(5.4)	W6F-000018

Heavy-Duty Hanger

Use components at right to hang Tool Rail from overhead supports

Hanging a tool rail from an overhead structure may be the best way to put a workstation where it's needed. 250 lb. capacity hangers, for use with WS60 steel track, are available as individual components only...not as kits. Thru bolts both top and bottom (see photo) act as a safety net. Thru bolts included with the mounting bases. Tool track must be supported every six feet to preserve 250 lb. capacity rating. Vertical C-60 supports must be field-cut to length to support rail at desired height.

DESCRIPTION	MODEL NUMBER
Mounting Base for C-60 Track	WS60-MB
C-60 Hanger Coupler	WS60-HC
Hardware Kit*	WS60-HW

*Hardware Kit includes (4) 1/2 x 1 1/2 bolts, nuts, lock washers and flat washers required to attach hanger coupler to mounting base.

THRU BOLTS FOR SAFETY
(included with base)

VERTICAL C-60 TRACK
Length to suit.

WS60-MB MOUNTING BASE

HORIZONTAL C-60 TRACK
Length to suit.

WS60-HC HANGER COUPLER
Supports and joins lengths of C-60 track. Hanger may be rotated 90°.

WS60-EHT02 FESTOON TROLLEY
(shown)

WS60-BT TOOL TROLLEY may also be used.

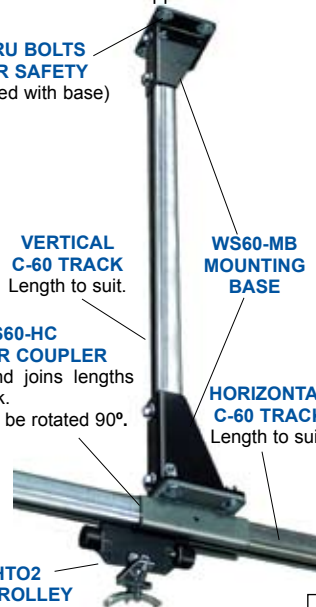

COMPONENTS

WS60 TRACK
Galvanized

RAIL LENGTH ft. (m)	MODEL NUMBER
6.0 (1.8)	WS60-G06
12.0 (3.6)	WS60-G12
18.0 (5.4)	WS60-G18

USE: Horizontal supports, rail for lateral movement of tools, controls, hoists, etc; up to 250 lbs. (113 kg) maximum total load.

WS60-CP RAIL COUPLER
Zinc plated steel.
USE: Joins track sections.

WS60-HG HANGER
Zinc plated steel.
USE: Hangs/supports WS60 track from overhead beams, joists, or other structures.

WS60-ES END STOP
Zinc plated steel.
USE: Installs in rail to stop trolley

WS60-HC HANGER/COUPLER
Zinc plated steel.
USE: Joins track sections.

WS60-BT ROLLING TROLLEY
Black polyester finish.
USE: Supports tools, balance reels, torque reels, push button control stations.

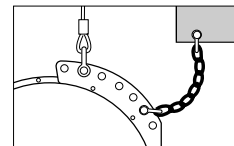

SAFETY CHAIN

Strongly recommended, steel link chain prevents balancer or tool rail from accidental fall. Includes clevis both ends.

RAIL LENGTH ft. (m)	MODEL NUMBER
1.0 (0.3)	SC-BG1
2.0 (0.6)	SC-BG2
3.0 (0.9)	SC-BG3

WS-UB6 U-BOLT ASSEMBLY
Zinc plated steel

USE: Secures WS60-MB mounting base or other flat plates to 3" dia. vertical column

FESTOON COMPONENTS

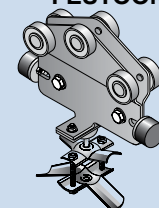

WS60-EHT01 (02, 03) FESTOON TROLLEY
Black polyester finish.
USE: Supports cable or hose in festoon system.

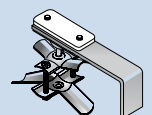

WS60-EC01 (02, 03) END CLIP
Black polyester finish.
USE: Secures cable or hose and acts as end stop in festoon system

CABLE/HOSE SIZE TABLE

0.31"-0.59" o.d.....01
0.60"-0.94" o.d.....02
0.95"-1.25" o.d.....03

ACCESSORIES



HEAVY DUTY TOOL CRANES

50 lb. or 250 lb. CAPACITY

Rugged bridge crane design concept allows overhead tool handling with maximum safety and minimum cost. Uses proven components rolling in standard WS-50 or WS-60 (steel) or WA-50 (aluminum) rails. 250 lb. capacity unit features doubled tool rail for maximum strength on spans over 6'. To speed installation, trolleys, hangers and tool track bridge are pre-assembled into single units, as is tool rail. Balance reel and tool not included.

50 lb. (22.5 kg) CAPACITY

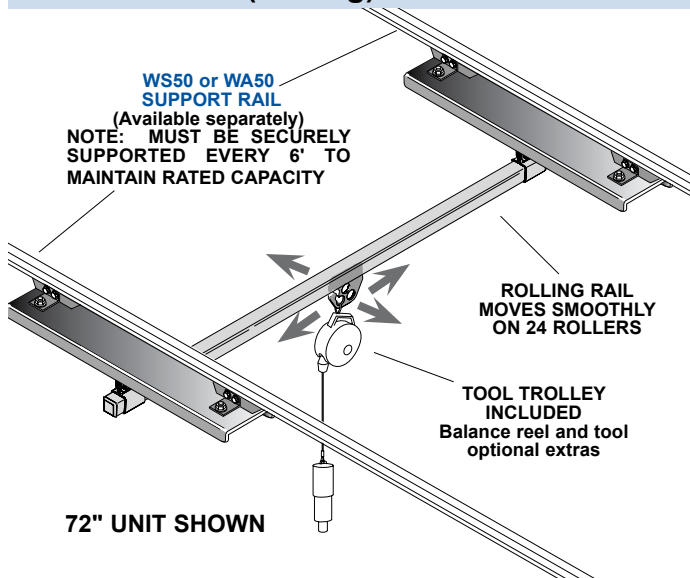

250 lb. (112.5 kg) CAPACITY

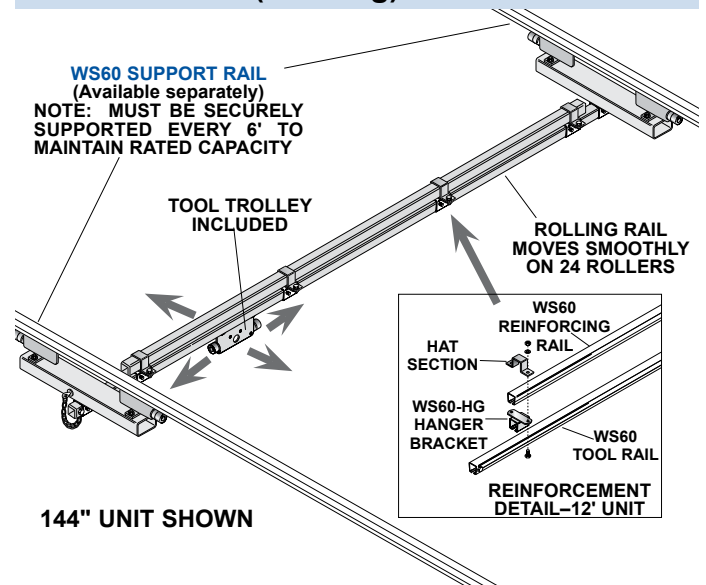

ASSEMBLY DETAILS

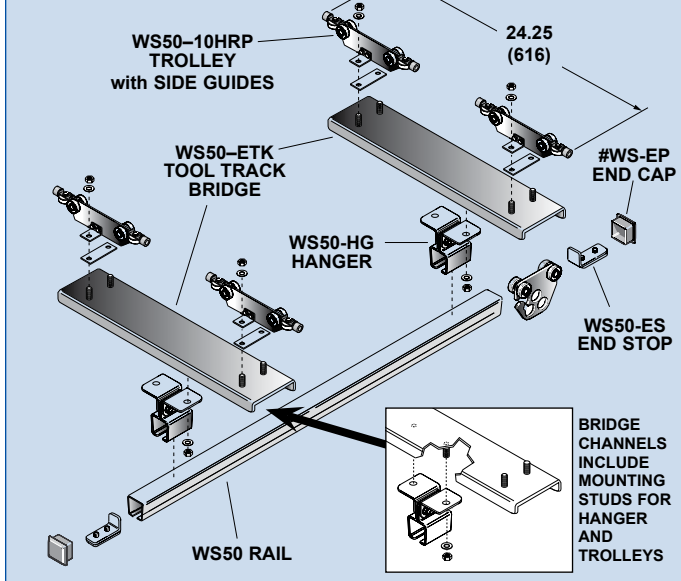

ASSEMBLY DETAILS

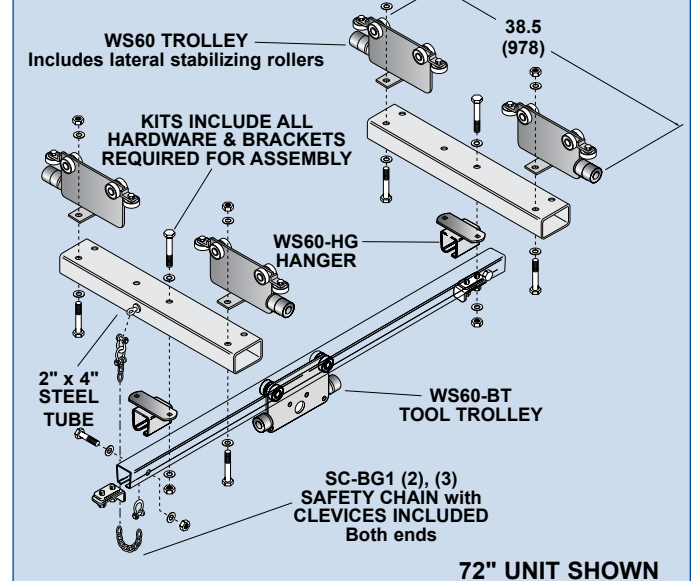

Heavy Duty Rolling Rail mounts in two parallel rails, which must be supported every 6' (1.8m) to maintain rated capacity. Recommended distance between support rails is length of tool rail less 12" (305mm). **MAXIMUM RATED CAPACITY OF ROLLING RAIL** includes tool, balancer, and attachments.

50 lb. Capacity Rolling Tool Rail includes (4) WS50-10HRP plain trolleys, (2) WS50-ETK tool track bridges, (2) WS50-HG hanger brackets, (1) WS50-BTL tool trolley, (2) WS-EP end caps, (2) WS50-ES end stops, (1) WS50 tool rail (length per model) and all assembly hardware.

250 lb. Capacity Rolling Tool Rail includes (4) WS60-FT trolleys, (2) 2" x 4" steel tool track bridges, (2) WS60-HG hanger brackets, (1) WS60-BT tool trolley, (2) WS60-ES end stops, (1) WS60 tool rail (length per model), (1) WS60 reinforcing rail (144" unit only), (2) safety chains, assembly brackets and hardware.

MODEL CHART

DESCRIPTION	TOOL RAIL in. (mm)	CAPACITY lbs. (kg)	MODEL NUMBER
4 Ft. Overhead Tool Crane	48" (1219)	50 lbs. (22.7 kg)	WS50-ET04
5 Ft. Overhead Tool Crane	60" (1524)	50 lbs. (22.7 kg)	WS50-ET05
6 Ft. Overhead Tool Crane	72" (1829)	50 lbs. (22.7 kg)	WS50-ET06
9 Ft. Overhead Tool Crane	108" (2743)	50 lbs. (22.7 kg)	WS50-ET09
12 Ft. Overhead Tool Crane	144" (3658)	50 lbs. (22.7 kg)	WS50-ET12
6 Ft. Overhead Tool Crane	72" (1829)	250 lbs. (113.6 kg)	WS60-ET06
12 Ft. Overhead Tool Crane	144" (3658)	250 lbs. (113.6 kg)	WS60-ET12

NOTE: For best results, tool rail width should not exceed six times the trolley wheelbase. Example: 24"(2 ft.) x 6 = 12 ft.