

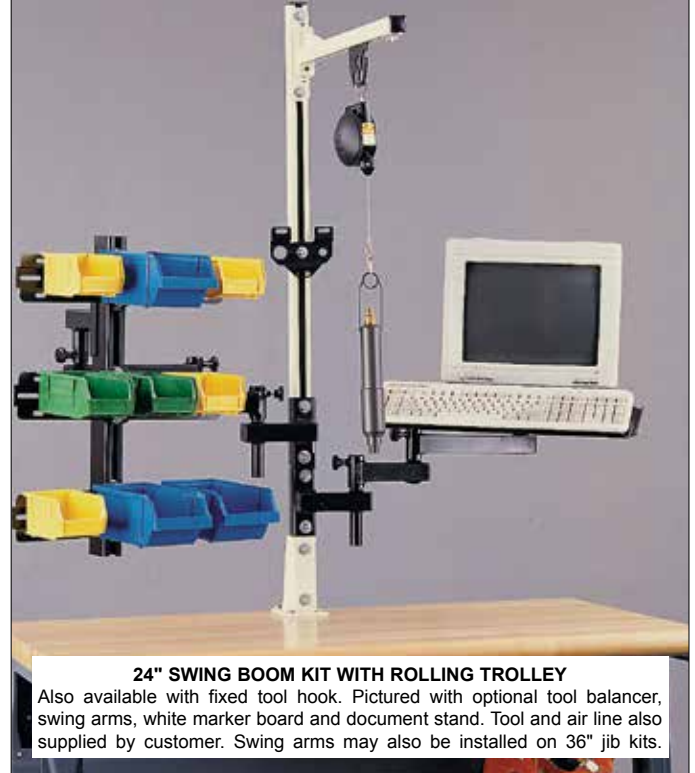

SINGLE COLUMN KITS are the efficient and economical way to meet ergonomic requirements. Each kit is complete with 180° swing or fixed boom, safety hook or balancer trolley and Universal Bracket for mounting everything from an air line fitting to peg board. Some models also include tool balancer, coiled air line, brass air line fitting and cord grip for use with electric tools. It's ready to mount on your work bench then customize...add swing arms with attachments, as shown below right, or other items as required. Horizontal boom has rated maximum capacity of 30 lbs.(13.5 kg). Bolts to any bench top. Hardware for mounting jib to bench not included. Balancer is easily adjusted to support tool weight allowing maximum productivity with minimum effort. Tool not included.



**36" SWING BOOM KIT WITH TOOL TROLLEY**  
Except for tool and hardware to attach jib to your bench top, what you see here is what you get. Swing arms may be installed on 36" jib kits.



**24" SWING BOOM KIT WITH ROLLING TROLLEY**  
Also available with fixed tool hook. Pictured with optional tool balancer, swing arms, white marker board and document stand. Tool and air line also supplied by customer. Swing arms may also be installed on 36" jib kits.

**36" (914mm) LONG BOOM WORK STATION KIT** (above, left) includes (1) fixed or swing 3 ft. WS30 swing boom, (1) 5 ft. WS50 vertical column, (1) 1.5, 2.5, or 5.0 lb.tool balancer, (1) balancer trolley, (1) end stop (with trolley only), (2) end caps, (1) WS-UH universal bracket, (1) brass air fitting, (1) cord grommet, (1) coiled 1/4" air line, (1) mounting base, all hardware required for assembly. Mounting fasteners not included. Does not include tool.

**24" (610mm) LONG BOOM WORK STATION KIT** (above, right) includes (1) fixed or swing 2 ft. WS30 boom, (1) 4 ft. WS50 vertical column, (1) balancer trolley or end stop hook, (1) end stop (with trolley only), (2) end caps, (1) angle bracket (fixed boom only), (1) WS-UH universal bracket, (1) mounting base, and all assembly hardware. Does not include fasteners for mounting base to bench. Does not include swing arms, balance reel, tool, air line or fittings shown in illustration.

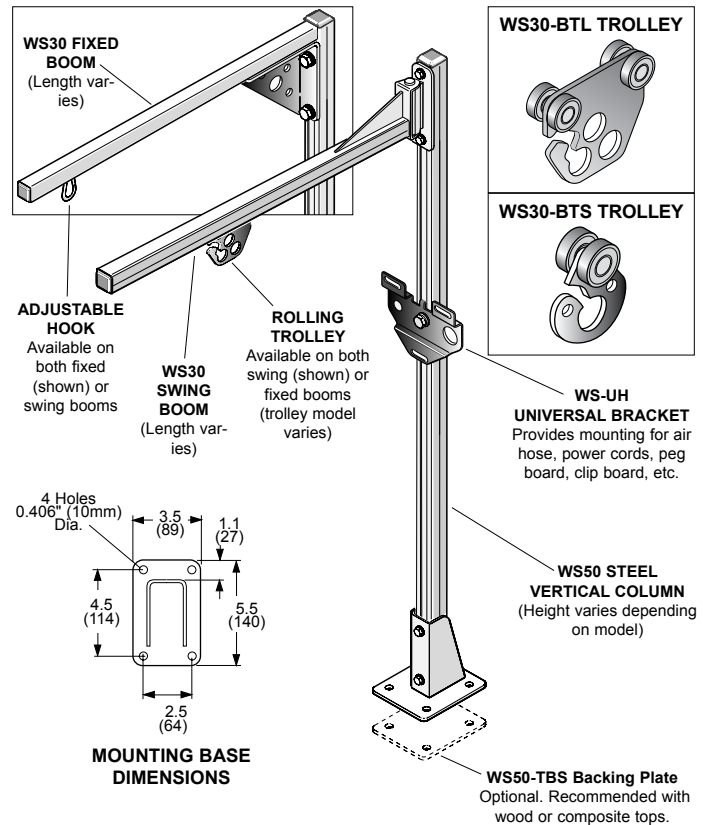

**WS30 boom for total loads to 30 lbs. (13.5 kg)**

Min - Max BALANCER CAPACITY	TROLLEY MODEL NUMBER	BOOM LENGTH & TYPE	VERTICAL COLUMN HEIGHT	WITH HOOK MODEL NO.	WITH TROLLEY MODEL NO.
0.5-1.5 lbs	WS30-BTS	36" Swing	5' (1.5m)	na	WTS-050301
1.5-3.0 lbs.	WS30-BTS	36" Swing	5' (1.5m)	na	WTS-050302
3.0-5.0 lbs.	WS30-BTS	36" Swing	5' (1.5m)	na	WTS-050305
0.5-1.5 lbs	WS30-BTS	36" Fixed	5' (1.5m)	na	WTF-050301
1.5-3.0 lbs.	WS30-BTS	36" Fixed	5' (1.5m)	na	WTF-050302
3.0-5.0 lbs.	WS30-BTS	36" Fixed	5' (1.5m)	na	WTF-050305
na	WS30-BTL*	24" Swing	4' (1.2m)	WHS-020400	WTS-020400
na	WS30-BTL*	24" Fixed	4' (1.2m)	WHF-020400	WTF-020400

\* Only on models supplied with trolley.

# TOOL RAIL KITS

## DUAL RAIL, DUAL COLUMN, BENCH SUPPORTED

KITS



**DUAL COLUMN WORKSTATION KITS** include two straight rails, your choice of three mounting base styles and in a range of heights to fit virtually any bench and any task you have. Height of horizontal support rails is adjustable, as is position of rails and width (distance between vertical columns). Kits include one WS30 and one WS50 rail. Either or both may be used as tool rail by adding **optional** balancer trolleys. Trolley mounted TORQ-ARM™ may be used, as can most accessories. Additional components may be added to make these workstations even more functional. Consult your Hubbell Workplace Solutions distributor or contact the factory for more details.

**TOOL RAIL KITS** include (1) WS30 rail with hangers, (1) WS50 rail with hangers, (2) WS50 vertical columns, (2) WS50 horizontal 36" rails, (2) angle brackets with hardware, (2) bases as shown, (4) end stops, (8) end caps, and all assembly hardware.

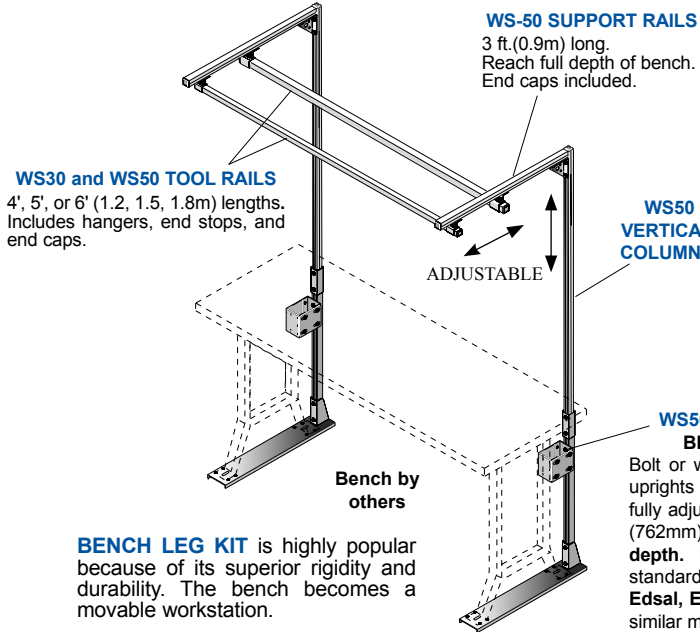

RAIL WIDTH		HEIGHT ABOVE BENCH			
		7 ft.(2.1m) (1)		7 ft.(2.1m) (1)	
ft.	(m)	30"(762) BASE	Shipping Weight	36"(914) BASE	Shipping Weight
4.0	(1.2)	#WKF-030740	82 lbs	#WKF-030746	90 lbs
5.0	(1.5)	#WKF-030750	86 lbs	#WKF-030756	94 lbs
6.0	(1.8)	#WKF-030760	90 lbs	#WKF-030766	98 lbs

**NOTE 1:** Nominal floor to top of vertical rail is 7'(2.1m). For 8'(2.4m) high models, change 7 in model number to 8, ie: WKF-030840

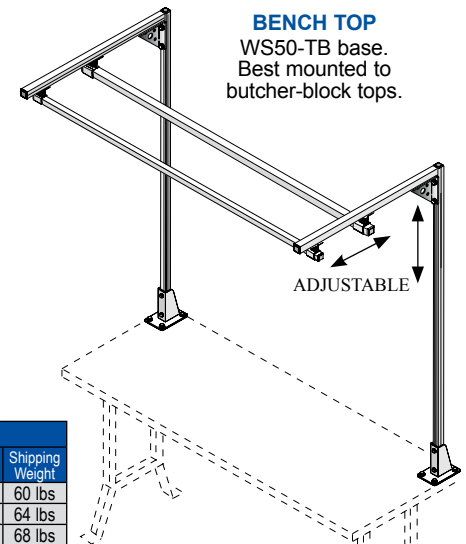

### STRAIGHT RAIL BENCH TOP KITS

RAIL WIDTH		HEIGHT ABOVE BENCH			
		5 ft.(1.5m) (2)		6 ft.(1.8m) (2)	
ft.	(m)	Shipping Weight	Shipping Weight	Shipping Weight	Shipping Weight
4.0	(1.2)	#WGB-030540	56 lbs	#WGB-030640	60 lbs
5.0	(1.5)	#WGB-030550	60 lbs	#WGB-030650	64 lbs
6.0	(1.8)	#WGB-030560	64 lbs	#WGB-030660	68 lbs

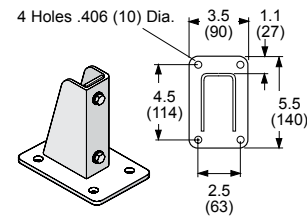
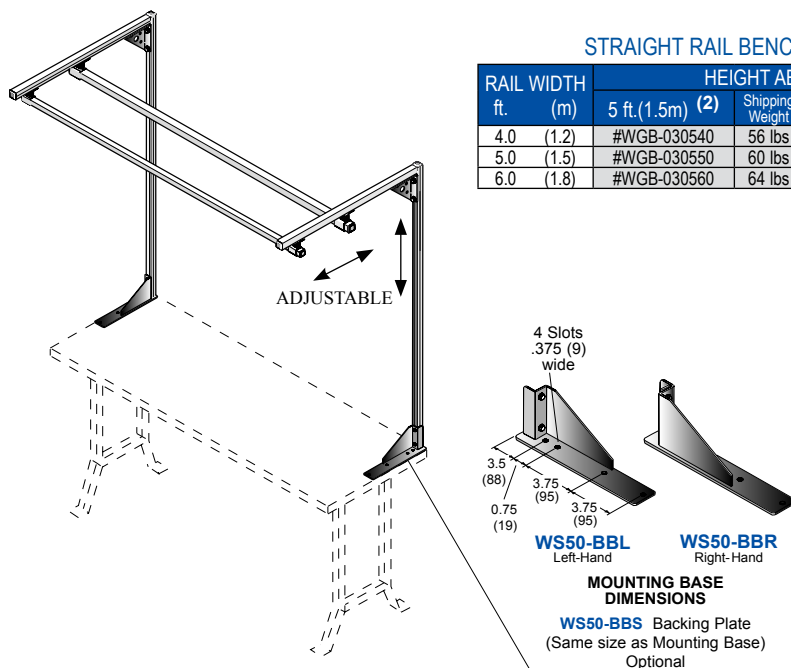

**WS50-TBS** Backing Plate (Same size as Mounting Base) Optional

### Optional For All Bench Top Kits

**BALANCER TROLLEY**  
WS30-BTL for WS30 rail.  
WS50-BTL for WS50 rail.  
Order separately.

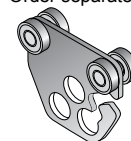

RAIL WIDTH		HEIGHT ABOVE BENCH			
		5 ft.(1.5m) (2)		6 ft.(1.8m) (2)	
ft.	(m)	Shipping Weight	Shipping Weight	Shipping Weight	Shipping Weight
4.0	(1.2)	#WKB-030540	66 lbs	#WKB-030640	70 lbs
5.0	(1.5)	#WKB-030550	70 lbs	#WKB-030650	74 lbs
6.0	(1.8)	#WKB-030560	74 lbs	#WKB-030660	78 lbs

**TABLE BRACKET** WS50-BBR and WS50-BBL bases. Predrilled to fit **Equipto** and **Lyon** steel tops.

**NOTE 2:** Height of bench will determine Tool Rail height.



# CURVED RAIL FOLLOWS THE WORK GUIDES TOOLS AND CONTROLS AROUND CORNERS

UNIQUE DIAMOND RAIL track and matching trolleys allow tools or control boxes to follow assembly line or conveyor path. Curved sections with 3 ft. (0.9m) radius form 90° corner and connect to other curved or straight track sections for smooth, non-stop trolley movement. Design and build your own system from components shown below. Threaded hangers may be hung from overhead beams or from WS50 rail using standard track nut. Trolleys include safety flanges to prevent fall if rollers fail. Capacity 30 lbs. (13.5 Kg).

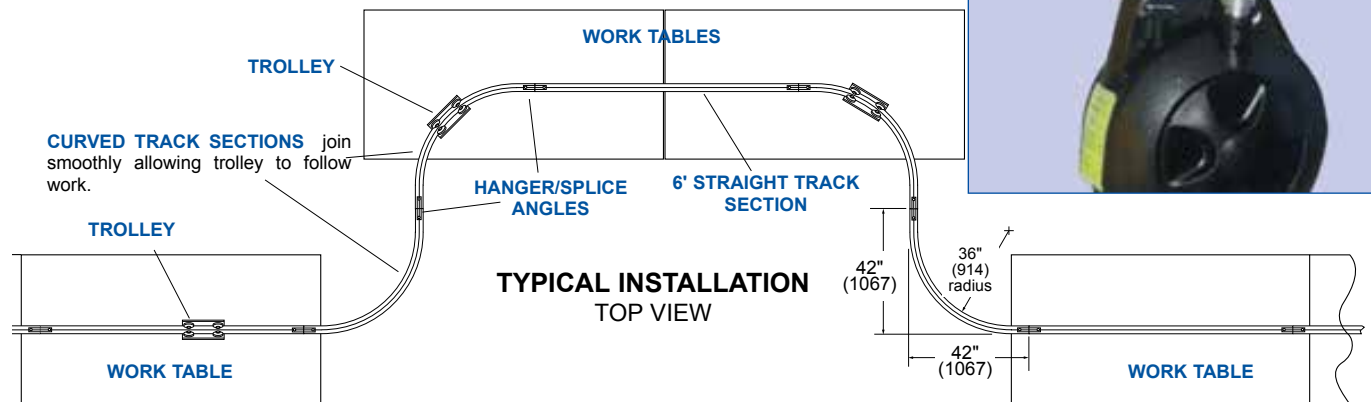
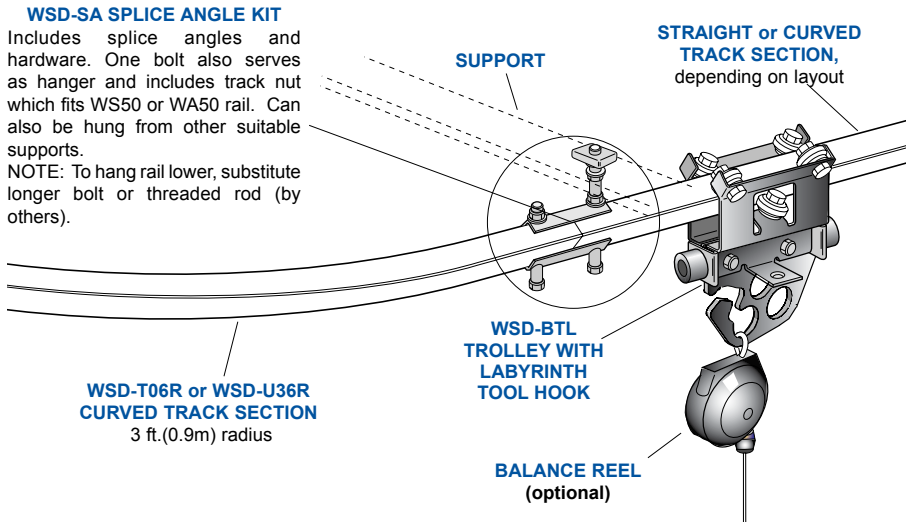

<b>COMPONENT CHART</b>		
DESCRIPTION	FINISH	MODEL NO.
6' (1.8m) STRAIGHT TRACK SECTION	BEIGE POLYESTER	WSD-T06
	UNFINISHED	WSD-U06
90° x 36" (914 mm) RADIUS CURVED TRACK SECTION	BEIGE POLYESTER	WSD-T36R
	UNFINISHED	WSD-U36R
SPLICE ANGLE KIT (includes (2) angles, hanger bolt, splice bolt, nuts & washers)	ZINC PLATED	WSD-SA
END STOP KIT (right, top) (includes end stop, hanger bolt, nuts & washers)	ZINC PLATED	WSD-ES
TROLLEY-LABYRINTH TOOL HOOK	BLACK POLYESTER	WSD-BTL
FESTOON TRAILER TROLLEY*	BLACK POLYESTER	WSD-RC12

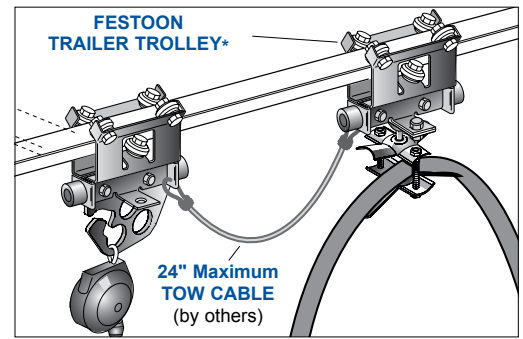
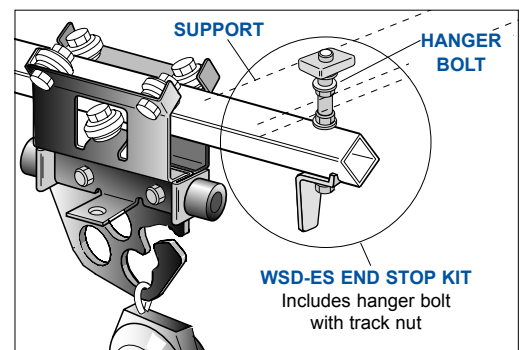

\* **FESTOON TRAILER TROLLEY** (right, bottom) provides easy management of cord or hose supplying power to tool. Fits cable or hose 0.60–0.94" (15–24mm) diameter. Tow cable connecting tool trolley to trailer trolley should not exceed 24" in length.