

Tool Balancers & Workstation Kits



ERGO-1 Tool Balancers

ERGO-1 tool balancers are the economical choice for balancing tools weighing up to 5 lbs (2.3kg). The molded ABS housing has a smooth exterior with rounded edges designed for maximum ergonomic appeal. ERGO-1 balancers are the most modern and easiest to adjust. Each balancer incorporates all of the important functions expected of a world class product.

- Hand-windable spring tension adjustment knob is flush with the housing
- Push-button to easily release spring tension
- Rugged steel upper swivel hook with secondary safety cable provision
- Over-sized cable opening with direct in-line pull to reduce cable wear
- 270 lb (121.5kg) test 0.047" (1.2mm) dia. 7x7 strand galvanized steel aircraft cable nylon covered to 0.063" (1.6mm) OD
- Adjustable cable stop and lower safety hook



UP TO
5lbs

Applications



Light Duty Manufacturing



Packaging & Shipping Station



Distribution Facilities

ERGO-2 Tool Balancers

ERGO-2 reels feature rugged steel construction with black polyester baked finish, reinforced hanging bracket with forged clevis for ceiling mounting and extra holes for safety chain attachment. Spring is permanently lubricated and adjustable for balancing tool in normal working zone (6-18 in. [152-457mm]). Cable is 920 lb. (414kg) test 0.09" (2.3mm) dia. 7x7 strand galvanized steel aircraft cable nylon covered to 0.12" (3.0mm) OD. Includes safety tool clip and adjustable cable stop.

Applications

- Manufacturing and assembly workstations
- Natural gas vehicle fueling stations
- Packaging and shipping stations



UP TO
27lbs



ERGO-3 Tool Balancers



ERGO-3 tapered drum tool balancers keep tools within reach and reduce damage to tools by suspending them out of the way above the work surface. Tapered drum compensates for changing spring rate—as the tool is lowered, and the spring is wound more tightly, the effective drum diameter increases to compensate for the increased force.

- Rugged die cast aluminum housing
- Both top and bottom hooks have spring-loaded safety latches
- Heavy duty steel wire rope
- Automatic safety catch prevents free-spooling if springs fail (not available on HBLBH02/HBLBH05)
- Easy adjustment with everyday tools from outside housing

UP TO
308 lbs



Applications



Heavy Duty Manufacturing



Automotive



Forging Plants

Accessories



ADJUSTABLE CABLE SADDLE

Provide strain relief for electrical cable or air hose



SHOCK-STOP

Minimize cable damage caused by over-tensioned balancers



SAFETY CABLE/CHAIN

Secondary safety measure to prevent balancer accidental fall



OVERHANG CABLE

Brings tool closer to work area without unwinding cable



BALANCER TROLLEYS

Add balancer trolleys to a tool rail kit for improved tool range and versatility

Workstation Kits

Available in a range of heights to fit virtually any bench and task, dual column workstation kits include two straight rails and your choice of two mounting base styles. The height of horizontal support rails, the position of the rails and the width (distance between vertical columns) are all adjustable. Kits include one WS30 and one WS50 rail. Either or both rail may be used as tool rail by adding optional balancer trolleys. Additional components are available to enhance the functionality of these fully customizable workstations.



- Adjustable and customizable to fit virtually any bench and task
- Kit bases are designed to fit most benches from Edsal, Equipto, Lyon, Penco and similar manufacturers
- Superior rigidity and durability

Tool rail kits include

- (1) WS30 rail with hangers
- (1) WS50 rail with hangers
- (2) WS50 vertical columns
- (2) WS50 horizontal 36" rails
- (2) angle brackets with hardware
- (2) bases as shown
- (4) end stops
- (8) end caps
- All assembly hardware

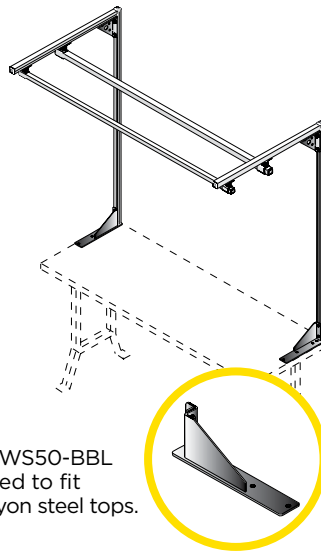
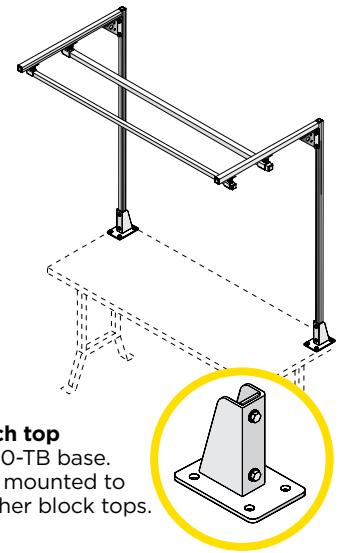

Table bracket
WS50-BBR & WS50-BBL bases. Predrilled to fit Equipto and Lyon steel tops.



Bench top
WS50-TB base. Best mounted to butcher block tops.





Workstation Accessories



Most components which make up ToolAssistPro kits are available separately. Components are often added to basic kits, further customizing them to fit the task. Workstation accessories increase utilitarian value and make the workplace more user friendly by adding functions. Accessories and components can be installed easily on ToolAssistPro fixed or portable workstation kits. Just slide them into place and tighten.

POWER BARS

Power bars clamp to steel or aluminum rail to provide convenient outlets for electric tools and lights.

- Grounded 15A outlets and plugs
- On/off switch and circuit breaker with reset
- Mounting bracket and hardware in length to fit workbench



MANIFOLD WITH BRACKETS

Redesigned square tubing provides 66% more volume than the legacy round tube, making this manifold ideal for workstations where multiple tools are used. Drilled and tapped for 3/8" NPT air inlets and outlets. Mounts to vertical columns or top rails. Beige polyester finish. Mounting hardware included.

- 3/8" NPT air inlets and outlets
- Mounts to vertical columns or top rails
- Mounting hardware included



BALANCER TROLLEYS

Balancer trolleys allow for greater tool versatility within a workstation. Optionally add them to a tool rail kit for improved tool range.

- Universal style bracket can hang a variety of objects
- Double or single roller guides swing smoothly along tool rail
- Black polyester finish



Ordering Information

ERGO-1 Tool Balancers

Description	Load lbs (kg)		Cable Length* ft (m)	Reel Weight lbs (kg)	Catalog Number
	Min	Max			
Balancer for loads up to 5 lbs	0.5 (0.2)	1.5 (0.7)	6 (1.8)	1.3 (0.6)	HBLBD01
	1.5 (0.5)	3.0 (1.4)	6 (1.8)	1.3 (0.6)	HBLBD03
	3.0 (1.4)	5.0 (2.3)	6 (1.8)	1.5 (0.7)	HBLBD05

*Cable lengths listed are for 'active' or 'working' cable. Includes cable stop and safety hook.



ERGO-2 Heavy Duty Tool Balancers

Description	Ratchet Lock	Load lbs (kg)		Cable Length* ft (m)	Reel Weight lbs (kg)	Catalog Number
		Min	Max			
Balancers (constant pull reels) May be adjusted to balance through 6-18 in. (152/457mm) range.	No	3 (1.4)	7 (3.2)	8 (2.4)	6 (2.7)	HBLBG03
		5 (2.3)	10 (4.5)	8 (2.4)	6 (2.7)	HBLBG07
		8 (3.6)	12 (5.4)	8 (2.4)	7 (3.2)	HBLBG10
		10 (4.5)	15 (6.8)	8 (2.4)	8 (3.6)	HBLBG15
		16 (7.2)	23 (10.4)	8 (2.4)	8 (3.6)	HBLBG20
		16 (7.2)	23 (10.4)	8 (2.4)	8 (3.6)	HBLBG20SH**
		22 (9.9)	27 (12.2)	8 (2.4)	8 (3.6)	HBLBG25
Retractors (ratchet lock) Retract tool upward when manually released	Yes	3 (1.4)	7 (3.2)	8 (2.4)	6 (2.7)	HBLBG03L
		5 (2.3)	10 (4.5)	8 (2.4)	6 (2.7)	HBLBG07L
		8 (3.6)	12 (5.4)	8 (2.4)	7 (3.2)	HBLBG10L
		10 (4.5)	15 (6.8)	8 (2.4)	8 (3.6)	HBLBG15L
		16 (7.2)	23 (10.4)	8 (2.4)	8 (3.6)	HBLBG20L
		16 (7.2)	23 (10.4)	8 (2.4)	8 (3.6)	HBLBG20LSH**
		22 (9.9)	27 (12.2)	8 (2.4)	8 (3.6)	HBLBG25L
Torque reels*** (ratchet lock and longer cable)	Yes	3 (1.4)	7 (3.2)	15 (4.5)	8 (3.6)	HBLTQ1507
		5 (2.3)	10 (4.5)	15 (4.5)	10 (4.5)	HBLTQ1510
		10 (4.5)	15 (6.8)	15 (4.5)	12 (5.4)	HBLTQ1515

*Cable lengths listed are for 'active' or 'working' cable. Includes cable stop and safety hook. | **Includes HBLBGSH "Shock Stop." | ***Clevis mount. For rigid mount, add "R" suffix.



ERGO-3 Tapered Drum Tool Balancers

Description	Load* lbs (kg)		Cable Length** ft (m)	Reel Weight lbs (kg)	Catalog Number
	Min	Max			
Heavy-duty balancer for loads up to 308 lbs	1.1 (.05)	4.4 (2.0)	3.3 (1.0)	2.2 (1.0)	HBLBH02
	2.2 (1.0)	6.6 (3.0)	4.3 (1.3)	2.8 (1.3)	HBLBH03
	5.5 (2.5)	11 (5.0)	4.3 (1.3)	3.3 (1.5)	HBLBH05
	9.0 (4.1)	20 (9.1)	3.9 (1.2)	13.4 (6.1)	HBLBH09
	20 (9.1)	33 (15.0)	3.9 (1.2)	13.4 (6.1)	HBLBH15
	33 (15.0)	48 (21.8)	4.5 (1.4)	22.6 (10.3)	HBLBH22
	48 (21.8)	66 (30.0)	4.5 (1.4)	22.6 (10.3)	HBLBH30
	66 (30.0)	88 (40.0)	4.5 (1.4)	27.0 (12.2)	HBLBH40
	88 (40.0)	110 (50.0)	4.5 (1.4)	27.0 (12.2)	HBLBH50
	110 (50.0)	132 (60.0)	4.5 (1.4)	31.4 (14.2)	HBLBH60
	132 (60.0)	154 (70.0)	4.5 (1.4)	31.4 (14.2)	HBLBH70
	154 (70.0)	187 (85.0)	4.5 (1.4)	58.4 (26.5)	HBLBH85
	187 (85.0)	220 (100.0)	4.5 (1.4)	56.0 (25.4)	HBLBH100
	220 (100.0)	264 (120.0)	4.5 (1.4)	60.0 (27.2)	HBLBH120
264 (120.0)	308 (140.0)	4.5 (1.4)	61.0 (27.7)	HBLBH140	

*Load includes hose or cord and other attachments which must be supported by balancer. | **Cable lengths listed are for 'active' or 'working' cable. Includes cable stop and safety hook.





Adjustable Cable Saddle

Description	Cable Diameter in (mm)		Catalog Number
	Min	Max	
Hangs from balancer cable above tool to provide strain relief for electrical cable or air hose. Available in three sizes. Includes safety clip.	0.3 (7)	0.59 (14)	HBLCSF1
	0.6 (15)	0.94 (23)	HBLCSF2
	0.95 (24)	1.25 (31)	HBLCSF3



“Shock Stop” Shock Absorber

Description	Catalog Number
Minimize cable damage often caused by overtensioning tool balancers. “Shock Stop” kit is easily installed. Can be used on ERGO-2 balancer. Kit includes spring, cable stops, all hardware.	HBLBGSH



Overhang Cable

Description	Length ft (m)	Catalog Number
Nylon covered steel cable with safety clip. Brings tool closer to work area without unwinding cable from reel or mounting reel at a lower height.	3 (0.9)	HBLOC03
	5 (1.5)	HBLOC05
	10 (3.0)	HBLOC10
	15 (4.6)	HBLOC15



Safety Cable/Chain

Description	For use with	Length ft (m)	Catalog Number
Strongly recommended, secondary steel cable or steel link chain. Prevents balancer from accidental fall. Balancers have extra holes for cable or chain.	HBLBD01-05	1 (0.3)	HBLSCBD1*
	HBLBG03-25	1 (0.3)	HBLSCBG1**
	HBLBG03L-25L	2 (0.6)	HBLSCBG2**
	HBLTQ1057-15	3 (0.9)	HBLSCBG3**
	HBLBH03-30	3 (0.9)	HBLSCBG3**
	HBLBH40-140	3 (0.9)	HBLSCBH3**



*Nylon covered steel cable. | **Steel link chain.

Straight Tool Rail Kits

Description	Rail Length ft (m)	Height Above Bench ft (m)	Catalog Number
Straight rail bench top kit. Best mounted to butcher block tops.	6.0 (1.8)	5.0 (1.5)	HBLWGB030560
Straight rail table top kit. Table brackets predrilled to fit Equipto and Lyon steel tops.	6.0 (1.8)	5.0 (1.5)	HBLWKB030560

Height of bench will determine tool rail height.



Power Bars

Description	Catalog Number
60 in. power bar with 60 in. mounting bar	HBLWPB505A



Manifold with Brackets

Description	Width ft (m)	# of Taps	Catalog Number
Mounts to vertical columns or top rails on workstations	5 (1.5)	5	HBLWMAN05C



Balancer Trolleys

Description	Catalog Number
Balancer trolley	HBLWS50BTL
Single roller balancer trolley	HBLWS50BTS



Contact Us

Count on Hubbell Wiring Device-Kellems for the most reliable and innovative wiring device product line in North America.

 custserv@hubbell.com

 (800) 288-6000

 Find your local representative at www.hubbell.com/wiringdevice-kellems

Online Resources

The Hubbell Wiring Device-Kellems website offers fast and convenient information through our online catalog, technical support, videos and more.

Visit www.hubbell.com/wiringdevice-kellems.

Literature Support

Hubbell offers an extensive literature library for product support. Downloadable PDFs are available online.



Full Line Catalog

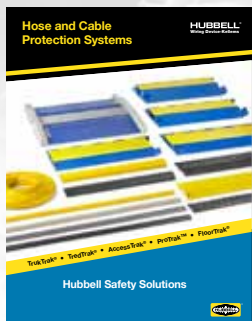

Hose and Cable Protection Systems



Safety Product Guide



Cord Reels

HUBBELL[®]
Wiring Device-Kellems

www.hubbell.com/wiringdevice-kellems

