

NOTES:

- 1 CREEPAGE DISTANCE: 30.6" / 778mm
- 2 ARC DISTANCE: 13.7" / 349mm
- 3 NOMINAL VOLTAGE: 35kV
- 4 NOMINAL CURRENT: 1200A
- 5 VOLTAGE WITHSTAND, 60 sec.: 95kV
- 6 BIL : 200kV
- 7 ROUTINE TEST ACCORDING TO: CSA-C88.1-96
- 8 MAX. TORQUE APPLIED ON FLANGE BOLTS: 40 lbf·ft / 54.2 N·m
- 9 WEIGHT: 59 lb / 26.8 kg

REVISIONS					
ZONE	REV.	DESCRIPTION	DRAWN BY	DATE	APPR.
D6	A	BOTTOM THREAD LENGTH CHANGED FROM 2.25" TO 3.00"	M. FORGET	2021-07-15	J.V.

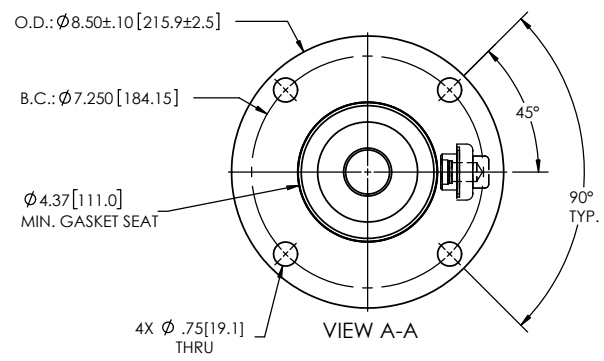
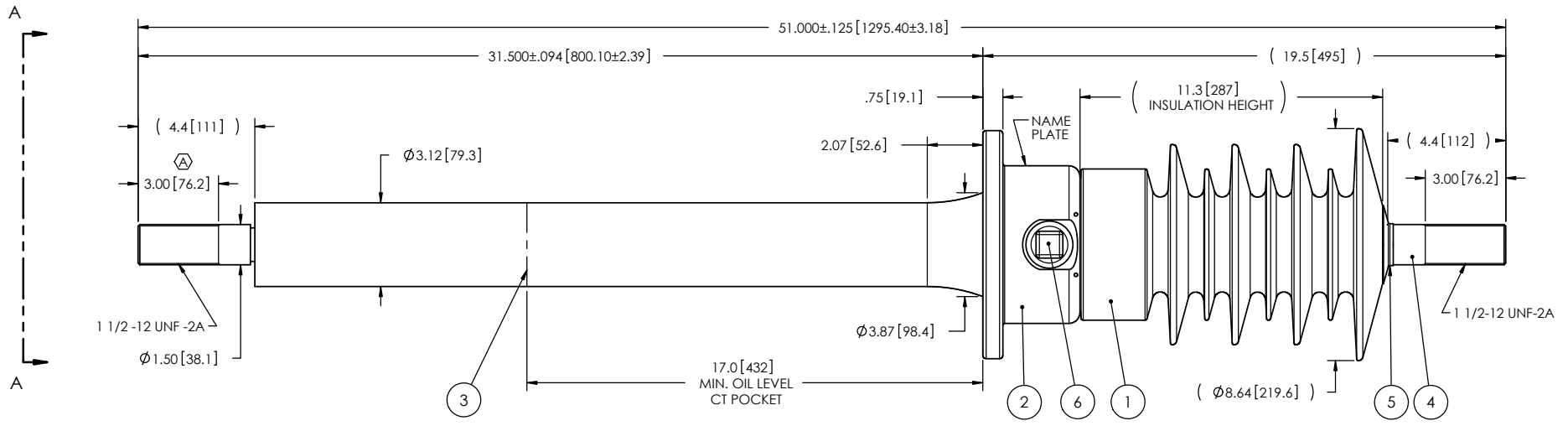

ITEM NO.	QTY	DRAWING NO.	PART NO.	DESCRIPTION	NOTE / MAT'L
6	1	S-1001-2022		CAPACITANCE TAP ASSEMBLY	ALUMINUM
5	1	S-1001-0007		CAP	COPPER
4	1	S-7124-6715		ROD ASSEMBLY	COPPER
3	1	S-7124-6714		SHIELD ASSEMBLY	COPPER
2	1	S-6626-6420		FLANGE	ALUMINUM
1	1	S-3193-9814	-001	CASTING, CYCLOALIPHATIC RESIN	EC-APG-02

PARTS LIST					
GENERAL TOLERANCES (UNLESS OTHERWISE SPECIFIED)			<p>Electro Composites solid HV bushings solution</p> <p>TITLE: SDC® BUSHING 35kV, 1200A MODEL: 200-012-B-066-05</p>		
X.	±0.125				
.X	±0.094			DRAWN BY: M. FORGET	DATE: 2018/10/19
.XX	±0.063			CHECK BY:	
.XXX	±0.031			PROJECT ENG.:	
ANGLES	±0.25°			PROJECT MANAGER:	
RADIUS	±0.031			SCALE: 1:6	GENERATED BY: SolidWorks 2013
REMOVE BURRS AND BREAK SHARP EDGES			DRAWING NO. S-3193-9814		
DIMENSIONS ARE IN INCHES (UNLESS OTHERWISE SPECIFIED)			REVISION A		
			SHEET 1 of 1		

This drawing is the proprietary property of Electro Composites (2008) ULC, not part of the public domain, and is issued with the express understanding and agreement that it is not to be reproduced or copied in whole or in part or issued for furnishing information to others, or used directly or indirectly, in any way detrimental to the interest of Electro Composites (2008) ULC and is to be returned upon request by Electro Composites (2008) ULC. All Rights Reserved.