

NOTES:

- 1 CREEPAGE DISTANCE: 13.7" / 348mm
- 2 ARC DISTANCE: 6.5" / 165mm
- 3 NOMINAL VOLTAGE: 15kV
- 4 NOMINAL CURRENT: 600A
- 5 VOLTAGE WITHSTAND, 60 sec.: 50kV
- 6 BIL.: 110kV
- 7 ROUTINE TEST ACCORDING TO: IEEE C57.19.01
- 8 MAX. TORQUE APPLIED ON FLANGE BOLTS: 40 lbf·ft / 54.2 N·m
- 9 WEIGHT: 17 lb / 7.7 Kg

REVISIONS					
ZONE	REV.	DESCRIPTION	DRAWN BY	DATE	APPR.

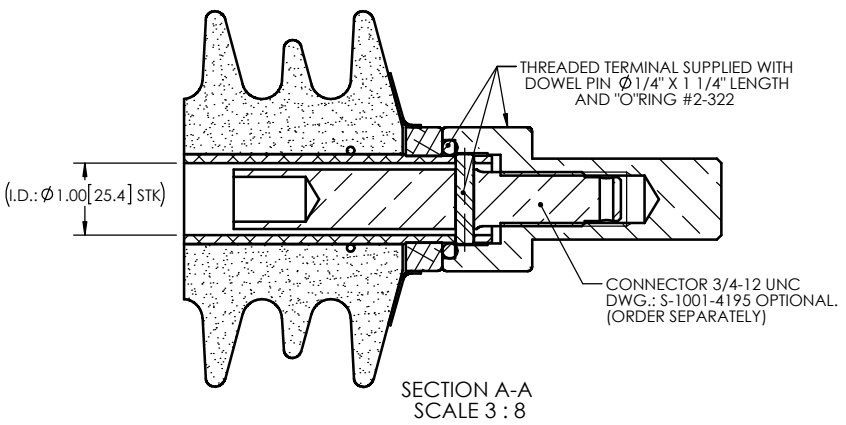
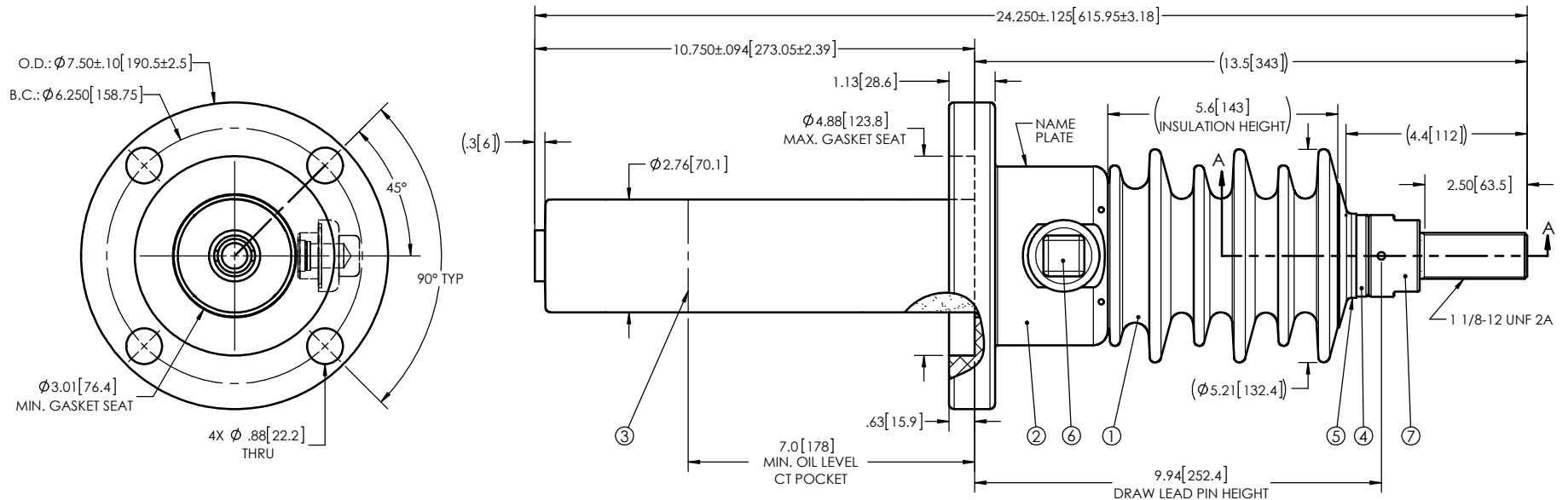

ITEM NO.	QTY	DRAWING NO.	PART NO.	DESCRIPTION	NOTE / MAT'L
7	1	S-4904-4657-0		THREADED TERMINAL KIT	COPPER
6	1	S-1001-2022		CAPACITANCE TAP ASSEMBLY	ALUMINUM
5	1	S-1344-0162-1		CAP	ALUMINUM
4	1	S-3858-3033		TUBE ASSEMBLY	ALUMINUM
3	1	S-3858-3032		SHIELD ASSEMBLY	COPPER
2	1	S-3858-3031		FLANGE	ALUMINUM
1	1	S-3858-3030	-001	CASTING, CYCLOALIPHATIC RESIN	EC-APG-02

PARTS LIST					
GENERAL TOLERANCES (UNLESS OTHERWISE SPECIFIED)			Electro Composites solid HV bushings solution TITLE: SDC® BUSHING 15kV, 600A MODEL: 110-006-T-086-01		
X.	± 0.125				
.X	± 0.094		DRAWN BY: J. CLICHE	DATE: 2015/11/09	
.XX	± 0.063		CHECK BY:		
.XXX	± 0.031		PROJECTING:		
ANGLES	$\pm 0.25^\circ$		PROJECT MANAGER:		
RADIUS	± 0.031				
REMOVE BURRS AND BREAK SHARP EDGES			FORMAT: A	CAGE CODE: S-3858-3030	DRAWING NO.: S-3858-3030
DIMENSIONS ARE IN INCHES (UNLESS OTHERWISE SPECIFIED)			SCALE: 1:4	GENERATED BY: SolidWorks 2013	REVISION: NR
				SHEET: 1 of 1	

This drawing is the proprietary property of Electro Composites (2008) ULC, not part of the public domain, and is issued with the express understanding and agreement that it is not to be reproduced or copied in whole or in part or issued for furnishing information to others, or used directly or indirectly, in any way detrimental to the interest of Electro Composites (2008) ULC and is to be returned upon request by Electro Composites (2008) ULC. All Rights Reserved.