

CATALOG NO.	STRANDED COPPER CONDUCTOR ACCOMMODATED			BOLT SIZE	METRIC BOLT SIZE	COLOR CODE	INSTALLATION TOOLING (# OF CRIMPS)										WIRE STRIP LENGTH			
	CODE (AWG)	NAVY	METRIC SIZE (CLASS 2)				DIE INFORMATION		MECHANICAL				HYDRAULIC					DIELESS (# CRIMPS)		
							DIE INDEX	TYPE	Y2MR	OUR840	MD6 MD7	MD7-34R	BC7500 Y500CT	Y34A, Y34B Y34BH	Y35, Y39, Y750 BAT35, BAT750 PAT750	Y46			Y45	
YA2C-L50	2# AWG	60	[35mm ² STR] [7.6]	7/8	[14]	BROWN	10	BROWN DIE SET	BROWN (2)	X2CRT (1)	W2CRT (1) W2CVT (1)	W2CRT (1) W2CVT (1)	X2CRT (1) W2CRT (1) W2CVT (1)	-----	U2CRT (1)	U2CRT (1)	U2CRT (1)	MECHANICAL: MY29-3 (1) MY29-11 (1)	15/16"	
								NEST	-----	-----	-----	-----	-----	B2CD (1)	A2CD (1)	U2CD-1 (1)	U2CD-1 (1)	U2CD-1 (1)		HYDRAULIC: Y644M (1) BAT644M (1)
								INDENTOR	-----	-----	-----	-----	-----	Y34PR	Y34PR	Y34PR	Y34PR			

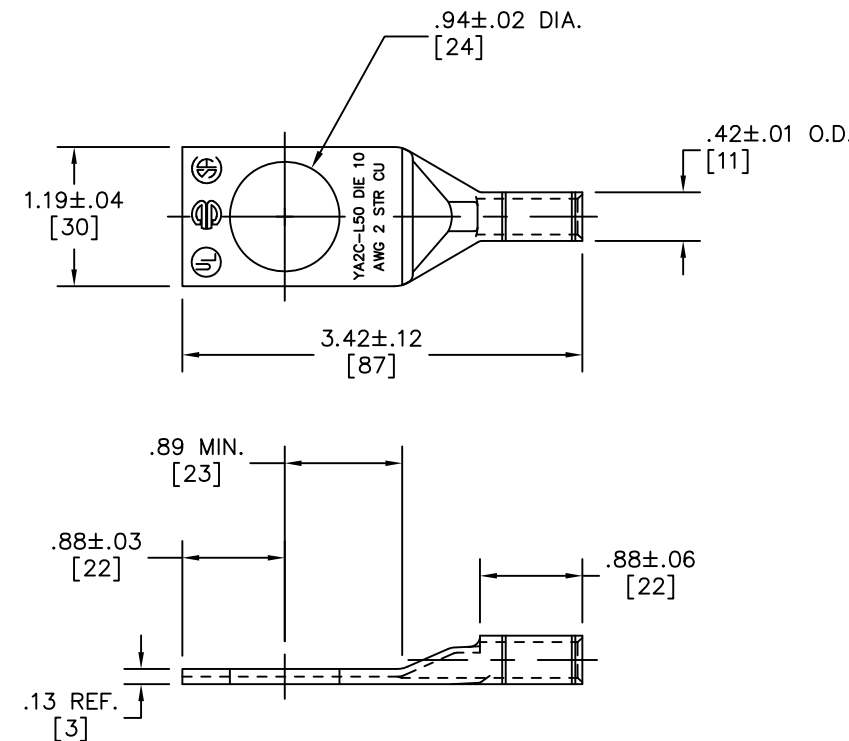

NOTES:

1. MATERIAL: COPPER TUBING.
2. FINISH: TIN PLATED
- CATALOG # PT6515 ADAPTOR IS REQUIRED TO USE "U" DIES IN Y45 SERIES TOOLS.
- CATALOG # PUADP-1 ADAPTOR IS REQUIRED TO USE "U" DIES IN Y46 SERIES TOOLS.
- Y35P3 INDENTOR ADAPTOR REQUIRED FOR Y34PR INDENTOR.
- PERMANENT DIE IN TOOLING.
7. DIMENSIONS IN [] BRACKETS ARE IN MILLIMETERS, ROUNDED OFF TO THE NEAREST MILLIMETER UNLESS OTHERWISE NOTED. METRIC DIMENSIONS ARE FOR REFERENCE ONLY.
- FOR USE BY CUSTOMERS THAT HAVE THIS HYPRESS.™ NO NEW Y34A HYPRESS.™ TOOLS ARE BEING PROCESSED. Y34A USES A--D TYPE NEST DIES.
9. "X", "W-RT", "W-VT" & "U" DIE SETS ARE COLOR CODED. "A" & "B" DIES ARE NOT COLOR CODED. NEST AND INDENTOR TYPE ARE NOT COLOR CODED.

TO ORDER BURNDY® PRODUCTS CALL UNITED STATES: 1-800-346-4175 (LONDONDERRY, NH) CANADA: 1-800-361-6975 (QUEBEC) 1-800-387-6487 (ALL OTHER PROVINCES) FOR PRODUCT INFO: http://www.burndy.com		HYLUG™	
		ITEM NO: 50261G	
		CAT NO: YA2C-L50	
		SCALE: 2/1	
		DRAWN BY: R. BOISVERT 08/26/02	
		CHECKER: J. MICHAUD 08/27/02	
		DSN APPVL: J. MICHAUD 08/26/02	
		MFG APPVL: ---	
		QC APPVL: R. ROBICHAU 08/27/02	
		MKT APPVL: ---	
		PROD FAM: ---	
		PROJECT #: ---	
		DOCUMENT TYPE: ---	
		REL LEVEL: ---	
		BURNDY	
		DRAWING NO 10013852	
		REV A	
		SIZE D	
		SHEET 1 OF 1	

REV.	DATE	DESCRIPTION	ECO	BY	C'K'D.
A	08/26/02	DRAWING RELEASED	7890	RB	JLM