

REV	DATE	DESCRIPTION	ECO	BY	C'HK.
B	11/07/2012	DRAWING RELEASED	29204	PM	MB

CATALOG NUMBER	RUN & TAP	RUN			TAP				DIE INDEX	INSTALLATION DATA, RUN & TAP		
		I.D.	O.D.	L	I.D.	O.D.	B	H		Y48B	Y60B	Y35, Y750 HYPRESS™ DIE SET & NO. OF CRIMPS PER END
YOT361R361R	477 (18-1) ACSR 477 (19, 37) AAC	1.05 [27]	1.34 [34]	12.37 [314]	1.05 [27]	1.34 [34]	4.41 [112]	6.25 [159]	317, 426 OR M	47 (2)	47 (2)	U317 (6) U-M (4)

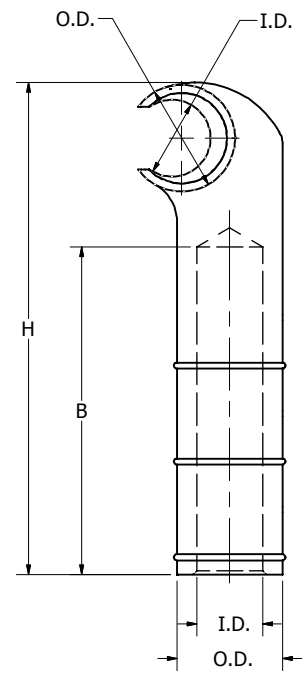
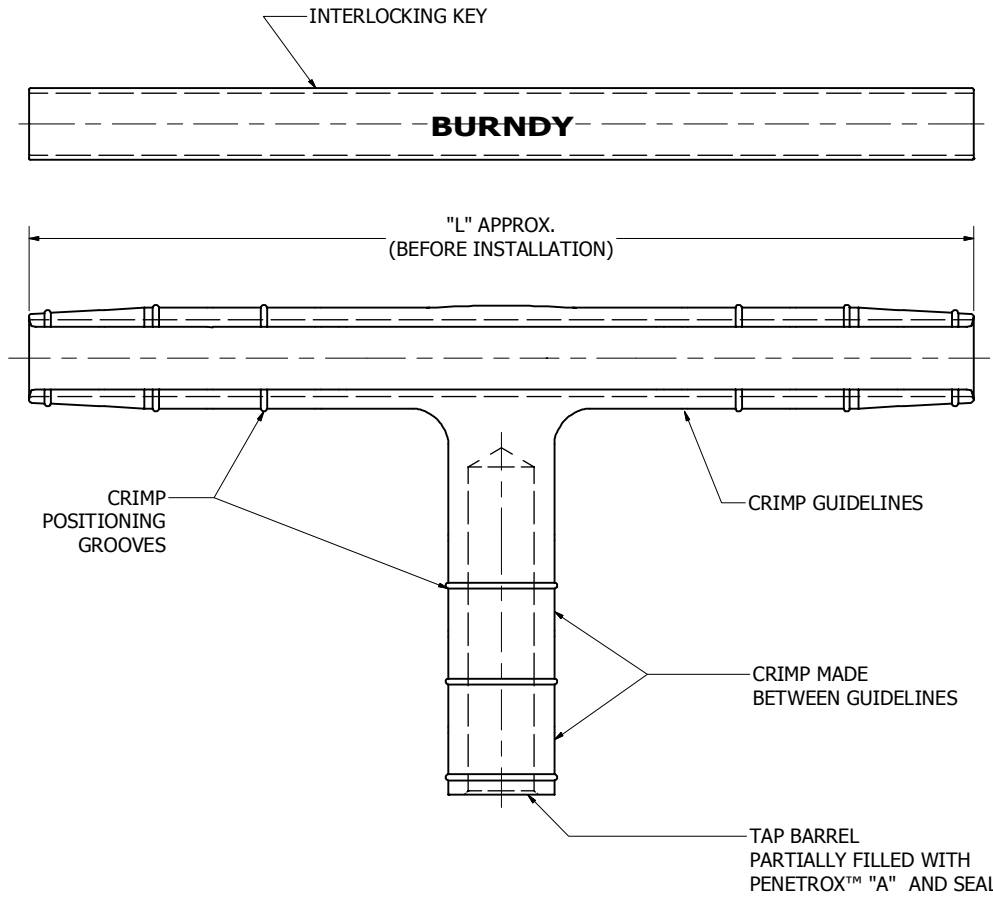

**NOTES:**

1. DIMENSIONS IN BRACKETS [ ] ARE IN MILLIMETERS ROUNDED OFF TO THE NEAREST MILLIMETER, UNLESS OTHERWISE SPECIFIED AND ARE FOR REFERENCE ONLY.
2. THIS DRAWING TO BE INTERPRETED PER ASME Y14.5M-1994.
3. SCRATCH BRUSH CONDUCTOR AND CONNECTOR CONTACT SURFACES DRY THEN APPLY PENETROX™ "A". PENETROX™ "A" NOT INCLUDED IN CATALOG NO., BUT CAN BE PURCHASED FROM BURNDY IN CANS OR PLASTIC SQUEEZE BOTTLES.
4. INSERT CONDUCTOR IN CONNECTOR AND MAKE REQUIRED NO. OF CRIMPS STARTING AT CROTCH AND WORKING TOWARDS ENDS.

TO ORDER BURNDY® PRODUCTS CALL		T - TAP	
UNITED STATES 1-800-346-4175 (LONDONDERRY, NH)		ITEM NO: 193930	
CANADA: 1-800-361-6975 (QUEBEC) 1-800-387-6487 (ALL OTHER PROVINCES)		CAT. NO: YTU--R--, YOT--R-- (TABLE)	
FOR PRODUCT INFO: <a href="http://www.burndy.com">http://www.burndy.com</a>		DRAWN BY: P LAPONUS 10/10/2002	
		CHECKED: K JACKSON 10/10/2002	
		DSN APRVL: K JACKSON 10/09/2002	
		MFG APRVL: --	
		QA APRVL: --	
		MKT APRVL: D HAMILTON 10/09/2002	
		PROD FAM: --	
		PROJECT #: --	
		DOCUMENT TYPE: SALES	
		REL LEVEL: Released	
		DRAWING NO: 10017359	
		SIZE: C	
		SHEET 1 OF 1	
		REV: B	