

DRAWING NO.
10046392

CATALOG NO.	CONDUCTOR		BOLT SIZE	BURNDY® INSTALLATION TOOLING (# CRIMPS)							
	FLEX	CODE (AWG)		DIE INDEX	COLOR CODE	MECHANICAL	HYDRAULIC			DIELESS (# CRIMPS)	WIRE STRIP LENGTH
YA32LNT12FXG1 YA32LNT12FXG2	313.1 kcmil 775/24	--	1/2 M12	18 OR 324	RED	W31VT (2)	Y750, Y35, Y39 BAT35, BAT750 PAT750	Y46, PAT46 4	Y45 3	HYDRAULIC: Y644M (1)	1-1/4"

REV	DATE	DESCRIPTION	ECO	BY	C'H'K.
B	4/15/2010 8:20:00 PM	ADDED YA32LNT12FXG2	20861	1A	MA

CATALOG NO.	C
YA32LNT12FXG1	.96[24]
YA32LNT12FXG2	1.29[33]

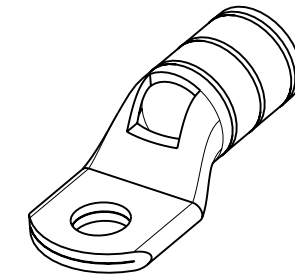
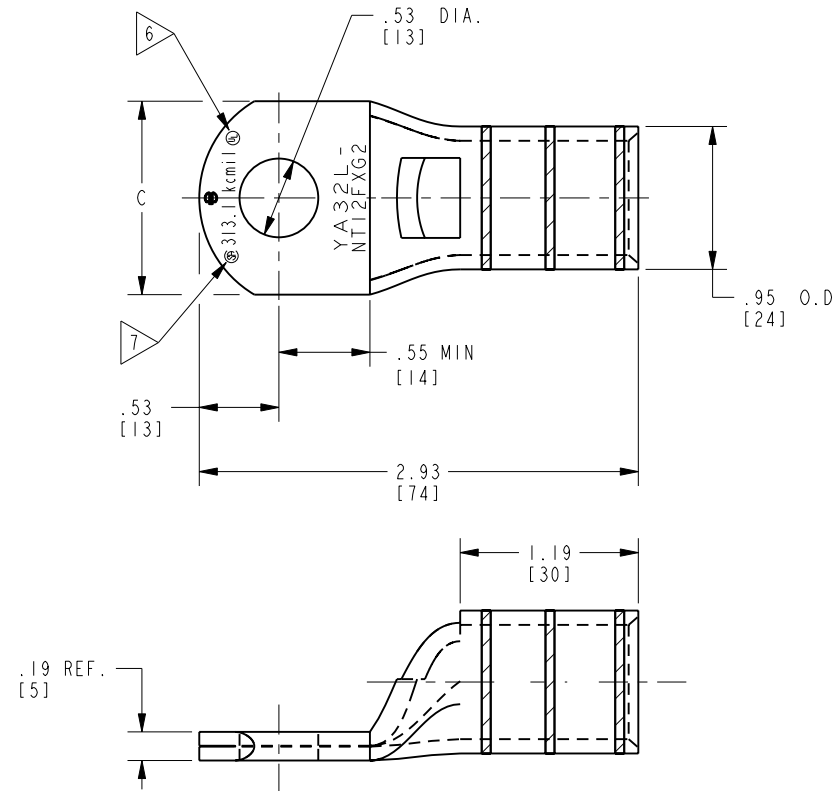

NOTES:

- MATERIAL : COPPER TUBING.
- FINISH: TIN PLATED.
- CATALOG # PT6505 ADAPTOR IS REQUIRED TO USE "U" DIES IN Y45 SERIES TOOLS.
- CATALOG # PUADP-I ADAPTOR IS REQUIRED TO USE "U" DIES IN Y46 SERIES TOOLS.
- DIMENSIONS IN BRACKETS [] ARE IN MILLIMETERS ROUNDED OFF TO THE NEAREST MILLIMETER, UNLESS OTHERWISE SPECIFIED, AND ARE FOR REFERENCE ONLY.
- CONNECTORS ARE UL LISTED.
- CONNECTORS ARE CSA CERTIFIED.

TO ORDER BURNDY® PRODUCTS CALL		HYLUG™	
UNITED STATES: 1-800-346-4175 (LONDONDERRY, NH)		ITEM NO: 10045315 & 30001201	
CANADA: 1-800-361-6975 (QUEBEC) 1-800-387-6487 (ALL OTHER PROVINCES)		CAT. NO: YA32LNT12FXG1 & YA32LNT12FXG2	
FOR PRODUCT INFO: http://www.burndy.com		DRAWN BY: D. BOISVERT 11/18/04	
		CHECKER: P. LAPONIUS 11/18/04	
		DSN APPVL: J. MICHAUD 10/27/04	
		MFG APPVL: N/A --	
		QA APPVL: J. BRODEUR 10/26/04	
		MKT APPVL: R. ROBICHEAU 10/26/04	
		SCALE: 1:1	
		PROD FAM: CM&R COMPRESSION	
		DRAWING NO	
		10046392	
		REV	
		B	
		SHEET 1 OF 1	

REV: PE0200