

- NOTES:
- 1 CREEPAGE DISTANCE: OUT: 44.5" / 1130mm IN: 25.6" / 650mm
 - 2 ARC DISTANCE: OUT: 18.0" / 458mm IN: 17.0" / 433mm
 - 3 NOMINAL VOLTAGE: 38kV
 - 4 NOMINAL CURRENT: 2500A
 - 5 VOLTAGE WITHSTAND, 60 sec.: 80kV
 - 6 BIL: 200kV
 - 7 ROUTINE TEST ACCORDING TO: IEEE C37.017
 - 8 MAX. TORQUE APPLIED ON FLANGE BOLTS: 40 lbf·ft / 54.2 N·m
 - 9 WEIGHT: 84 lb / 38.1 kg
 - 10 SILVER PLATED, AS PER ASTM B700, TYPE 1, GRADE D, CLASS N, NO NICKEL LAYER, FROM 13 TO 20 MICROMETERS THICKNESS

| REVISIONS | | | | | |
|-----------|------|----------------------------|-----------|------------|-------|
| ZONE | REV. | DESCRIPTION | DRAWN BY | DATE | APPR. |
| B4 | A | ADD EPDM GASKET TO BUSHING | M. FORGET | 2023-02-08 | Y.V. |

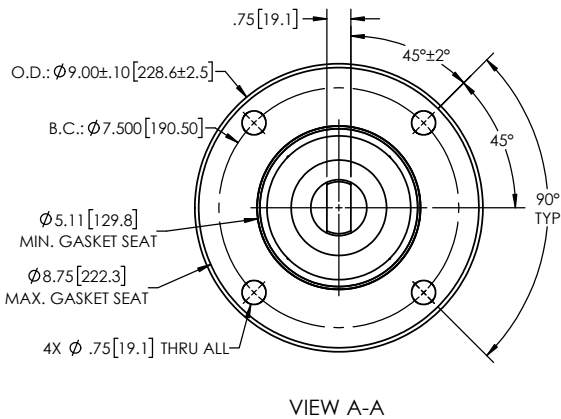
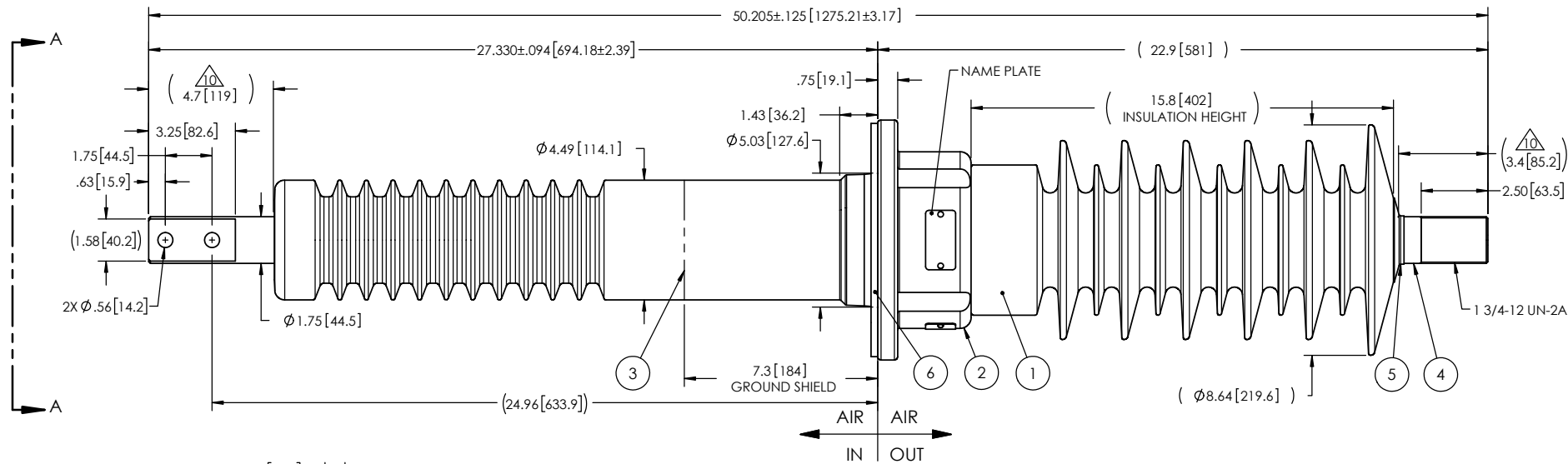

| ITEM NO. | QTY | DRAWING NO. | PART NO. | DESCRIPTION | NOTE / MAT'L |
|----------|-----|---------------|----------|------------------------------|--------------|
| 6 | 1 | S-7699-10418 | | GASKET | EPDM |
| 5 | 1 | S-1600-0587-0 | | CAP | COPPER |
| 4 | 1 | S-1548-9541 | | ROD ASSEMBLY | COPPER |
| 3 | 1 | S-1548-9540 | | SHIELD ASSEMBLY | COPPER |
| 2 | 1 | S-1548-9534 | | FLANGE | ALUMINUM |
| 1 | 1 | S-1548-9497 | -001 | CASTING CYCLOALIPHATIC RESIN | EC-APG-02 |

GENERAL TOLERANCES (UNLESS OTHERWISE SPECIFIED)

| | |
|--------|--------|
| X. | ±0.125 |
| .X | ±0.094 |
| .XX | ±0.063 |
| .XXX | ±0.031 |
| ANGLES | ±0.25° |
| RADIUS | ±0.031 |

REMOVE BURRS AND BREAK SHARP EDGES

DIMENSIONS ARE IN INCHES (UNLESS OTHERWISE SPECIFIED)

Electro Composites™
solid HV bushings solution

TITLE: SDC® BUSHING 38kV, 2500A
MODEL: 200-025-W-1005-00

DRAWN BY: A.SAVARD DATE: 2017/12/05

CHECK BY: PROJECT ENG.: PROJECT MANAGER:

FORMAT: A CAGE CODE: DRAWING NO.: S-1548-9497 REVISION: A

SCALE: 1:6 GENERATED BY: SolidWorks 2022 SHEET: 1 of 1

This drawing is the proprietary property of Electro Composites (2008) ULC, not part of the public domain, and is issued with the express understanding and agreement that it is not to be reproduced or copied in whole or in part or issued for furnishing information to others, or used directly or indirectly, in any way detrimental to the interest of Electro Composites (2008) ULC and is to be returned upon request by Electro Composites (2008) ULC. All Rights Reserved.