

DRAWING NO.
10051620

REV.	DATE	DESCRIPTION	ECO	BY	C'K'D.
A	12/8/04	DRAWING RELEASED	10262	PL	DS

BURNDY MOLD CAT. NO.	BURNDY ITEM NUMBER	CABLE		WELD METAL	HANDLE CLAMPS
		RUN	TAP		
B-8434*	10048220	1/2"	#6	32	B40-4565-00
B-8435*	10048221	1/2"	#4	32	B40-4565-00
B-537	10048222	1/2"	#2	90	B-106
B-538	10048223	1/2"	#1	90	B-106
B-539	10048224	1/2"	1/0	90	B-106
B-540	10048225	1/2"	2/0	90	B-106
B-541	10048226	1/2"	3/0	115	B-106
B-542	10048227	1/2"	4/0	115	B-106
B-543	10048228	1/2"	250 kcmil	150	B-106
B-544	10048229	1/2"	300 kcmil	200	B-106
B-8441	10048240	5/8"	#6	32	B40-4565-00
B-8442	10048241	5/8"	#4	32	B40-4565-00
B-545	10048242	5/8"	#2	90	B-106
B-546	10048243	5/8"	#1	90	B-106
B-547	10048244	5/8"	1/0	90	B-106
B-548	10048245	5/8"	2/0	115	B-106
B-549	10048246	5/8"	3/0	115	B-106
B-550	10048247	5/8"	4/0	115	B-106
B-551	10048248	5/8"	250 kcmil	150	B-106
B-552	10048249	5/8"	300 kcmil	200	B-106
B-553	10048250	5/8"	350 kcmil	200	B-106
B-555	10048251	5/8"	500 kcmil	250	B-106
B-8452*	10048262	3/4"	#6	45	B40-4565-00
B-8454*	10048263	3/4"	#4	65	B40-4565-00
B-556	10048264	3/4"	#2	90	B-106
B-557	10048265	3/4"	#1	90	B-106
B-558	10048266	3/4"	1/0	115	B-106
B-559	10048267	3/4"	2/0	115	B-106
B-560	10048268	3/4"	3/0	115	B-106
B-561	10048269	3/4"	4/0	115	B-106
B-562	10048270	3/4"	250 kcmil	150	B-106
B-563	10048271	3/4"	300 kcmil	200	B-106
B-564	10048272	3/4"	350 kcmil	200	B-106
B-566	10048273	3/4"	500 kcmil	250	B-106
B-567	10048274	3/4"	750 kcmil	2-200	B-107
B-569	10048279	1"	1/0	150	B-106
B-570	10048280	1"	2/0	150	B-106
B-571	10048281	1"	3/0	150	B-106
B-572	10048282	1"	4/0	150	B-106
B-573	10048283	1"	250 kcmil	200	B-106
B-574	10048284	1"	300 kcmil	200	B-106
B-575	10048285	1"	350 kcmil	200	B-106
B-577	10048286	1"	500 kcmil	250	B-106
B-578	10048287	1"	750 kcmil	2-200	B-107
B-579	10048288	1"	1000 kcmil	500	B-107

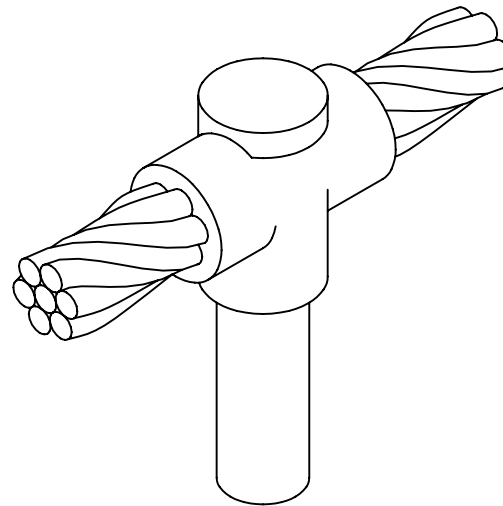

NOTES:

- BCR-2 TYPE MOLDS ARE USED TO JOIN HORIZONTAL THROUGH COPPER CABLE TO THE TOP OF A VERTICAL GROUND ROD.
- SIZE RANGE IS #6 THROUGH 1000 kcmil SOLID OR CONCENTRIC STRANDED COPPER CONDUCTORS; 1/2" THROUGH 1" FOR THE GROUND ROD.
- MOLDS LISTED ARE FOR CONCENTRIC STRANDED CABLE. ADD SUFFIX "-S" TO MOLD NUMBER FOR SOLID CONNECTORS.
- MOLDS LISTED ARE FOR COPPERCLAD GROUND RODS. FOR WELDING TO STEEL, STAINLESS STEEL OR GALVANIZED STEEL GROUND RODS ADD SUFFIX "-N" TO MOLD NUMBER.
- FOR HEAVY DUTY MOLDS ADD SUFFIX "H" TO THE MOLD NUMBER.
- REQUIRED TOOLS: HANDLE CLAMPS (SEE TABLE ABOVE). FOR HANDLES SEE DRAWING 10051615.
*SOLD COMPLETE WITH HANDLES
B38-0309-00 FLINT IGNITOR (DRAWING 10051616).
- OTHER RECOMMENDED ACCESSORIES: DRAWING 10051616
B40-0319-01: MOLD CLEANER FOR CARTRIDGE SIZES #15 - #65
B40-0319-03: MOLD CLEANER FOR CARTRIDGE SIZES #90 - #500
B38-3922-00: MOLD CLEANING BRUSH
B38-0135-00: CABLE CLEANING BRUSH
B38-0304-00: FILE
B38-0330-00: CABLE CLAMP

TO ORDER BURNDY® PRODUCTS CALL 1-800-346-4175 MANCHESTER, NH 03109, USA FOR PRODUCT INFO = http://www.burndy.com	
BURNDYWeld™ HORIZONTAL CABLE TO GROUND ROD	
ITEM NO: N/A	
CAT NO: BCR-2 SERIES	
SCALE: N/A	
DRAWN BY: P LAPONIUS 12/8/04	
CHECKER: D SHIBLJA 1/3/05	
DSN APPV: D SHIBLJA 1/13/05	
MFG APPV: ---	
QC APPV: J BRODEUR 1/14/05	
MKT APPV: R ROBICHEAU 1/18/05	
PROD FAM: ---	DRAWING NO
PROJECT # ---	10051620
DOCUMENT TYPE: Sales	SIZE
REL LEVEL: AutoCAD	D
	SHEET 1 of 1