

REV.	DATE	DESCRIPTION	ECO	BY	C'K'D.
A	12/8/04	DRAWING RELEASED	10262	PL	DS

BURNDY MOLD CAT. NO.	BURNDY ITEM NUMBER	CABLE		WELD METAL	HANDLE CLAMPS
		GROUND ROD	TAP		
B-5416	10048459	1/2"	#4	90	B-106
B-6165	10048460	1/2"	#2	90	B-106
B-5830	10048461	1/2"	#1	90	B-106
B-5940	10048462	1/2"	1/0	115	B-106
B-5850	10048463	1/2"	2/0	150	B-106
B-5833	10048464	1/2"	3/0	200	B-106
B-5380	10048465	1/2"	4/0	200	B-106
B-5972	10048466	5/8"	#4	90	B-106
B-5935	10048467	5/8"	#2	115	B-106
B-5699	10048468	5/8"	#1	115	B-106
B-5746	10048469	5/8"	1/0	150	B-106
B-5963	10048470	5/8"	2/0	200	B-106
B-5734	10048471	5/8"	3/0	250	B-106
B-5732	10048472	5/8"	4/0	250	B-106
B-5722	10048473	5/8"	250 kcmil	2-150	B-107
B-5698	10048474	3/4"	#4	90	B-106
B-5294	10048475	3/4"	#2	115	B-106
B-5390	10048476	3/4"	#1	115	B-106
B-6025	10048477	3/4"	1/0	150	B-106
B-5738	10048478	3/4"	2/0	200	B-106
B-6003	10048479	3/4"	3/0	250	B-106
B-2566	10048480	3/4"	4/0	250	B-106
B-5904	10048481	3/4"	250 kcmil	2-150	B-107
B-5857	10048482	3/4"	300 kcmil	2-200	B-107
B-5777	10048483	3/4"	350 kcmil	2-200	B-107
B-5961	10048484	3/4"	500 kcmil	3-200	B-107
B-5556	10048485	1"	#4	115	B-106
B-5555	10048486	1"	#2	150	B-106
B-6048	10048487	1"	#1	150	B-106
B-5992	10048488	1"	1/0	200	B-106
B-5877	10048489	1"	2/0	250	B-106
B-5821	10048490	1"	3/0	2-150	B-107
B-5820	10048491	1"	4/0	2-150	B-107
B-5807	10048492	1"	250 kcmil	2-200	B-107
B-5803	10048493	1"	300 kcmil	500	B-107
B-5561	10048494	1"	350 kcmil	500	B-107
B-5515	10048495	1"	500 kcmil	3-250	B-107
B-5513	10048496	1"	750 kcmil	2-500	B-107

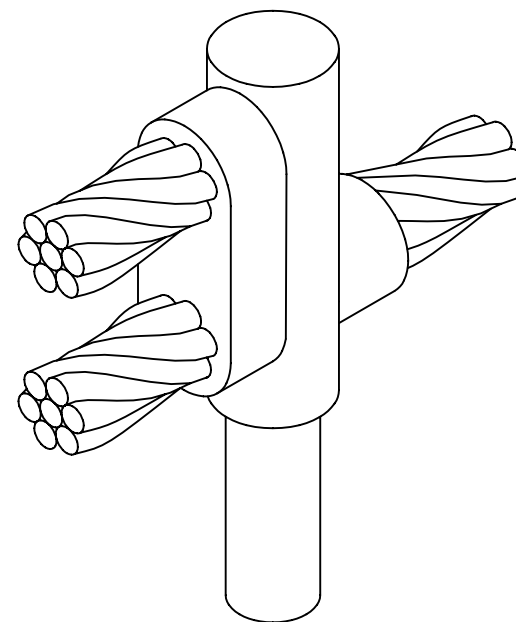

## NOTES:

- BCR-17 TYPE MOLDS ARE USED TO JOIN HORIZONTAL RUN AND TAP CABLES TO THE TOP OF A VERTICAL GROUND ROD.
- SIZE RANGE IS #4 THROUGH 750 kcmil SOLID OR CONCENTRIC STRANDED COPPER CONDUCTORS; 1/2" THROUGH 1" FOR THE GROUND ROD.
- MOLDS LISTED ARE FOR CONCENTRIC STRANDED CABLE. ADD SUFFIX "-S" TO MOLD NUMBER FOR SOLID CONNECTORS.
- MOLDS LISTED ARE FOR COPPERCLAD GROUND RODS. FOR WELDING TO STEEL, STAINLESS STEEL OR GALVANIZED STEEL GROUND RODS ADD SUFFIX "-N" TO MOLD NUMBER.
- FOR HEAVY DUTY MOLDS, ADD SUFFIX "H" TO MOLD NUMBER.
- REQUIRED TOOLS: HANDLE CLAMPS (SEE TABLE ABOVE). FOR HANDLES SEE DRAWING 10051615. B38-0309-00: FLINT IGNITOR (DRAWING 10051616).
- OTHER RECOMMENDED ACCESSORIES: DRAWING 10051616  
 B38-3922-00: MOLD CLEANING BRUSH  
 B38-0135-00: CABLE CLEANING BRUSH  
 B38-0330-00: CABLE CLAMP  
 B38-0304-00: FILE

TO ORDER BURNDY PRODUCTS CALL 1-800-346-4175  
 MANCHESTER, NH 03109, USA  
 FOR PRODUCT INFO = <http://www.fciconnect.com>

BURNDYWeld™ HORIZONTAL RUN AND TAP CABLES TO GROUND ROD

ITEM NO: N/A

CAT NO: BCR-17 SERIES

SCALE:	N/A
DRAWN BY:	P. LAPONIUS 12/8/04
CHECKER:	D. SHIBILIA 1/3/05
DSN APPVL:	D. SHIBILIA 1/13/05
MFG APPVL:	--
QC APPVL:	J. BRODEUR 1/14/05
MKT APPVL:	R. ROBICHEAU 1/18/04
PROD FAM:	--
PROJECT #:	1/18/05
DOCUMENT TYPE:	Sales
REL LEVEL:	AutoCAD

**BURNDY**

TO ORDER BURNDY® PRODUCTS CALL  
 UNITED STATES:  
 1-800-346-4175 (LONDONDERRY, NH)  
 CANADA:  
 1-800-361-6975 (QUEBEC)  
 1-800-387-6487 (ALL OTHER PROVINCES)  
 FOR PRODUCT INFO: <http://www.burndy.com>

DRAWING NO	REV
10051622	A
SHEET 1 OF 1	