

DRAWING NO.

10051628

BURNDY MOLD CAT. NO.	BURNDY ITEM NUMBER	CABLE SIZE	WELD METAL	HANDLE CLAMPS
B-628*~	10048681	#6	45	N/A
B-629*~	10048682	#4	45	N/A
B-630*~	10048683	#2	45	N/A
B-631*~	10048684	#1	65	N/A
B-7146	10048685	1/0	90	B-106
B-7075	10048686	2/0	90	B-106
B-2199	10048687	3/0	115	B-106
B-6114	10048688	4/0	115	B-106
B-2200	10048689	250 kcmil	115	B-106
B-2506	10048690	300 kcmil	150	B-106
B-2507	10048691	350 kcmil	200	B-106
B-2509	10048692	500 kcmil	200	B-106
B-2542	10048693	750 kcmil	2-150	B-107
B-2511	10048694	1000 kcmil	2-200	B-107

REV.	DATE	DESCRIPTION	ECO	BY	C'K'D.
B	8/2/2013	LOGO CHANGE	32732	VS	MB

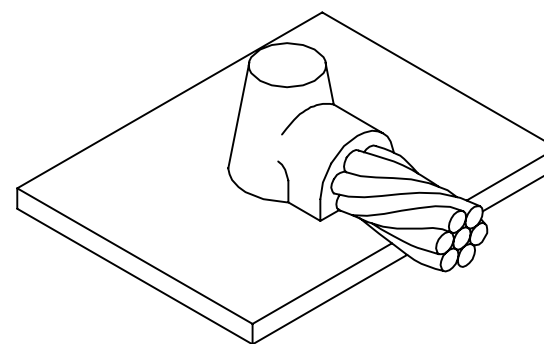

(CABLE IS ON THE SURFACE)

NOTES:

- BCS-8 TYPE MOLDS ARE USED TO TERMINATE A HORIZONTAL COPPER CABLE TO ANY HORIZONTAL STEEL SURFACE. NOTE THE CABLE IS 'ON' THE SURFACE.
- SIZE RANGE IS #6 THROUGH 1000 kcmil SOLID OR CONCENTRIC STRANDED COPPER CONDUCTORS.
- MOLDS LISTED ARE FOR CONCENTRIC STRANDED CABLE. ADD SUFFIX "-S" TO MOLD NUMBER FOR SOLID CONDUCTORS.
- FOR HEAVY DUTY MOLDS ADD SUFFIX "H" TO THE MOLD NUMBER.
- REQUIRED TOOLS: HANDLE CLAMPS (SEE TABLE ABOVE). FOR HANDLES SEE DRAWING 10051615.
*SOLD COMPLETE WITH FRAME
~B38-0309-00: FLINT IGNITOR (DRAWING 10051616).
- OTHER RECOMMENDED ACCESSORIES: DRAWING 10051616
B38-3922-00: MOLD CLEANING BRUSH
B38-0135-00: CABLE CLEANING BRUSH
B38-0330-00: CABLE CLAMP
B38-0101-00: RASP

TO ORDER BURNDY® PRODUCTS CALL
 UNITED STATES:
 1-800-346-4175 (LONDONDERRY, NH)
 CANADA:
 1-800-361-6975 (QUEBEC)
 1-800-387-6487 (ALL OTHER PROVINCES)
 FOR PRODUCT INFO: <http://www.burndy.com>

BURNDYWeld™ HORIZONTAL CABLE TO HORIZONTAL STEEL SURFACE

ITEM NO: N/A

CAT NO: BCS-8 SERIES

SCALE: N/A

DRAWN BY: P LAPONIUS 12/8/04

CHECKER: D SHIBILIA 1/3/05

DSN APPVL: D SHIBILIA 1/13/05

MFG APPVL: ---

QC APPVL: J BRODEUR 1/14/05

MKT APPVL: R ROBICHEAU 1/18/05

PROD FAM: ---

PROJECT #: ---

DOCUMENT TYPE: Sales

REL LEVEL: AutoCAD

DRAWING NO

10051628

SHEET 1 OF 1

REV

B