

DRAWING NO.
10051630

BURNDY MOLD CAT. NO.	BURNDY ITEM NUMBER	STUD SIZE	WELD METAL	HANDLE CLAMPS
B-602*~	10048733	#6	45	N/A
B-603*~	10048734	#4	45	N/A
B-604*~	10048735	#2	45	N/A
B-605*~	10048736	#1	65	N/A
B-8379	10048737	1/0	90	B-106
B-5331	10048738	2/0	115	B-106
B-8381	10048739	3/0	115	B-106
B-7192	10048740	4/0	150	B-106
B-8413	10048741	250 kcmil	150	B-106
B-8423	10048742	300 kcmil	200	B-106
B-8410	10048743	350 kcmil	250	B-106
B-5065	10048744	500 kcmil	2-150	B-107

REV.	DATE	DESCRIPTION	ECO	BY	C'K'D.
B	8/2/2013	LOGO CHANGE	32732	VS	MB

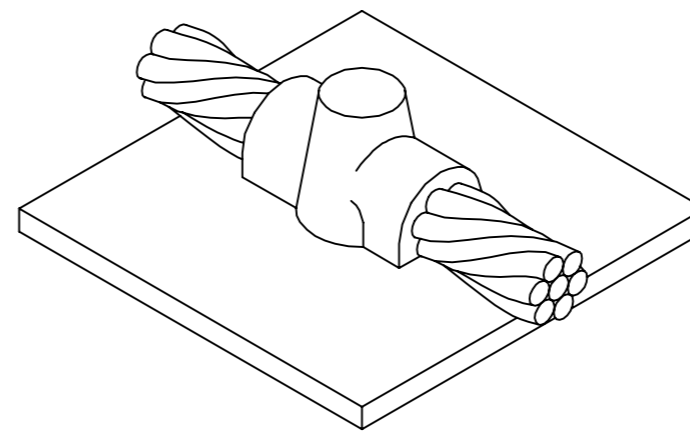

(CABLE IS ON THE SURFACE)

NOTES:

- BCS-9 TYPE MOLDS ARE USED TO JOIN HORIZONTAL THROUGH COPPER CABLE TO ANY HORIZONTAL STEEL SURFACE. NOTE THE CABLE IS 'ON' THE SURFACE.
- SIZE RANGE IS #6 THROUGH 500 kcmil SOLID OR CONCENTRIC STRANDED COPPER CONDUCTORS.
- MOLDS LISTED ARE FOR CONCENTRIC STRANDED CABLE. ADD SUFFIX "-S" TO MOLD NUMBER FOR SOLID CONDUCTORS.
- FOR HEAVY DUTY MOLDS ADD SUFFIX "H" TO THE MOLD NUMBER.
- REQUIRED TOOLS: HANDLE CLAMPS (SEE TABLE ABOVE). FOR HANDLES SEE DRAWING 10051615.
*SOLD COMPLETE WITH HANDLE FRAME.
~B38-0309-00: FLINT IGNITOR INCLUDED (DRAWING 10051616).
- OTHER RECOMMENDED ACCESSORIES: DRAWING 10051616
 B40-0319-01: MOLD CLEANER FOR CARTRIDGE SIZES #15 - #65
 B40-0319-03: MOLD CLEANER FOR CARTRIDGE SIZES #90 - #500
 B38-3922-00: MOLD CLEANING BRUSH
 B38-0135-00: CABLE CLEANING BRUSH
 B38-0101-00: RASP

TO ORDER BURNDY® PRODUCTS CALL UNITED STATES: 1-800-346-4175 (LONDONDERRY, NH) CANADA: 1-800-361-6975 (QUEBEC) 1-800-387-6487 (ALL OTHER PROVINCES) FOR PRODUCT INFO: http://www.burndy.com		BURNDYWeld™ HORIZONTAL THRU CABLE TO HORIZONTAL STEEL SURFACE	
		ITEM NO: N/A	
		CAT NO: BCS-9 SERIES	
		SCALE: N/A	
		DRAWN BY: P LAPONIUS 12/8/04	
		CHECKER: D SHIBILIA 1/3/05	
		DSN APPVL: D SHIBILIA 1/13/05	
		MFG APPVL: ---	
		QC APPVL: J BRODEUR 1/14/05	
		MKT APPVL: R ROBICHEAU 1/18/05	DRAWING NO
		PROD FAM: ---	10051630
		PROJECT #: ---	REV
		DOCUMENT TYPE: Sales	B
		REL LEVEL: AutoCAD	SHEET 1 OF 1